



US00D692897S

(12) **United States Design Patent**
Luijben

(10) **Patent No.:** **US D692,897 S**
(45) **Date of Patent:** **** Nov. 5, 2013**

(54) **CAR MOUNT**

(75) Inventor: **Stefan Arthur Luijben**, Helmond (NL)

(73) Assignee: **Vogel's Holding B.V.** (NL)

(**) Term: **14 Years**

(21) Appl. No.: **29/380,611**

(22) Filed: **Dec. 8, 2010**

(30) **Foreign Application Priority Data**

Aug. 18, 2010 (EM) 001744822

(51) **LOC (9) Cl.** **08-07**

(52) **U.S. Cl.**
USPC **D14/447**

(58) **Field of Classification Search**

USPC D14/447, 432, 433, 434, 439, 440, 451,
D14/452, 457, 239, 251, 253, 217, 374, 375,
D14/376, 377, 902, 216, 209.1, 204;
D12/415, 416; D3/218, 274, 318, 321,
D3/328; D6/406.3, 406.4; 190/117;
361/679.03, 679.09, 679.05, 679.26,
361/679.3, 679.55, 679.56, 679.27;
248/176.1, 917, 918, 919, 920, 921,
248/922, 923, 924, 682, 689, 690, 691, 692,
248/441.1, 444, 447, 451, 460, 463, 118,
248/118.5, 149, 150, 166, 434, 177.1;
D10/113.4; D16/242, 244, 245;
108/42, 152; 224/275

See application file for complete search history.

(56) **References Cited**

U.S. PATENT DOCUMENTS

D431,019 S * 9/2000 Richter D12/426.1
D543,985 S * 6/2007 Hussaini et al. D14/434

(Continued)

Primary Examiner — Angela J Lee

(74) *Attorney, Agent, or Firm* — Miller & Martin PLLC

(57) **CLAIM**

The ornamental design for a car mount, as shown and described.

DESCRIPTION

FIG. 1 is a front perspective view of the car mount shown with the front mount and rear bracket separated;

FIG. 2 is a front perspective view of the car mount of FIG. 1, but shown assembled;

FIG. 3 is a top plan view of the separated front mount shown in FIG. 1;

FIG. 4 is a top plan view of the assembled car mount;

FIG. 5 is a left elevation view of the separated car mount, but shown with a portion of the front mount rotated in an alternate upward position, the right elevation view being a mirror image thereof;

FIG. 6 is a left elevation view of the assembled car mount, the right elevation view being a mirror image thereof;

FIG. 7 is a bottom plan view of the separated car mount shown in FIG. 5;

FIG. 8 is a bottom plan view of the assembled car mount shown in FIG. 6;

FIG. 9 is a front elevation view of the front mount of the car mount shown in FIG. 1, the front elevation view of the assembled car mount being identical;

FIG. 10 is a front elevation view of the front mount of the car mount shown in FIG. 5, the front elevation view of the assembled car mount being identical;

FIG. 11 is a front elevation view of the rear bracket of the separated car mount shown in FIG. 1, shown without the front mount for clarity of illustration;

FIG. 12 is a back elevation view of the front mount of the separated car mount shown in FIG. 5, shown without the rear bracket for clarity of illustration

FIG. 13 is a back elevation view of the rear bracket of the separated car mount shown in FIG. 1, shown without the front mount for clarity of illustration; and,

FIG. 14 is a back elevation view of the assembled car mount shown with the portion of the front mount rotated in the alternate upward position.

The broken lines in FIG. 12 depict unclaimed environmental subject matter.

1 Claim, 14 Drawing Sheets

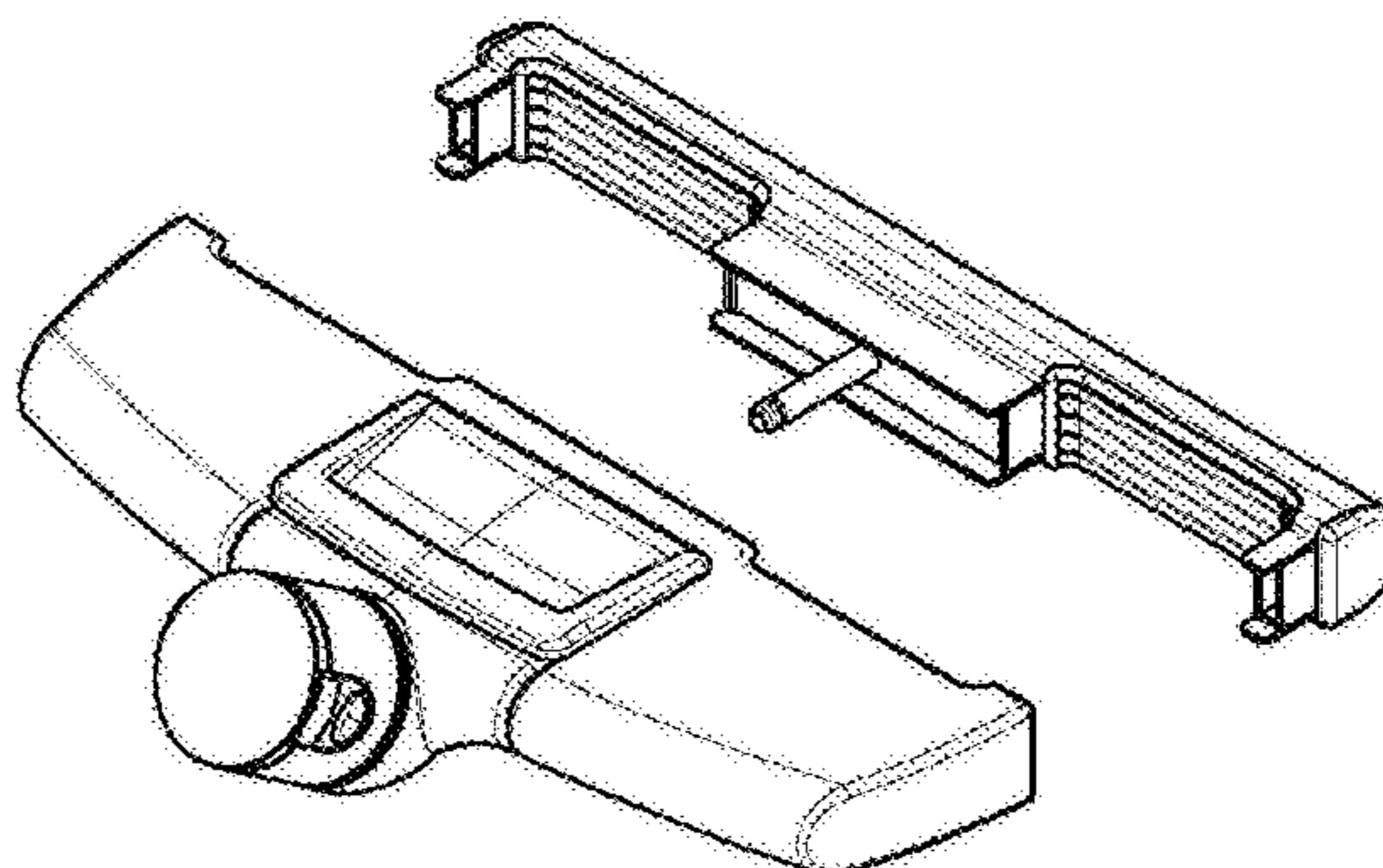

(56)

References Cited

U.S. PATENT DOCUMENTS

D557,207 S * 12/2007 Aguilar D13/108
D559,839 S * 1/2008 Vitito D14/239
D619,079 S * 7/2010 Bailo D12/416
7,812,784 B2 * 10/2010 Chang 345/1.1

D633,040 S * 2/2011 Le et al. D13/108
D641,610 S * 7/2011 Sedalo D8/354
D652,836 S * 1/2012 Voorhees D14/447
D657,364 S * 4/2012 Norman D14/451
D664,147 S * 7/2012 Zhao et al. D14/452
2012/0018471 A1 * 1/2012 Guillermo et al. 224/275
2012/0024920 A1 * 2/2012 Grolle et al. 224/275

* cited by examiner

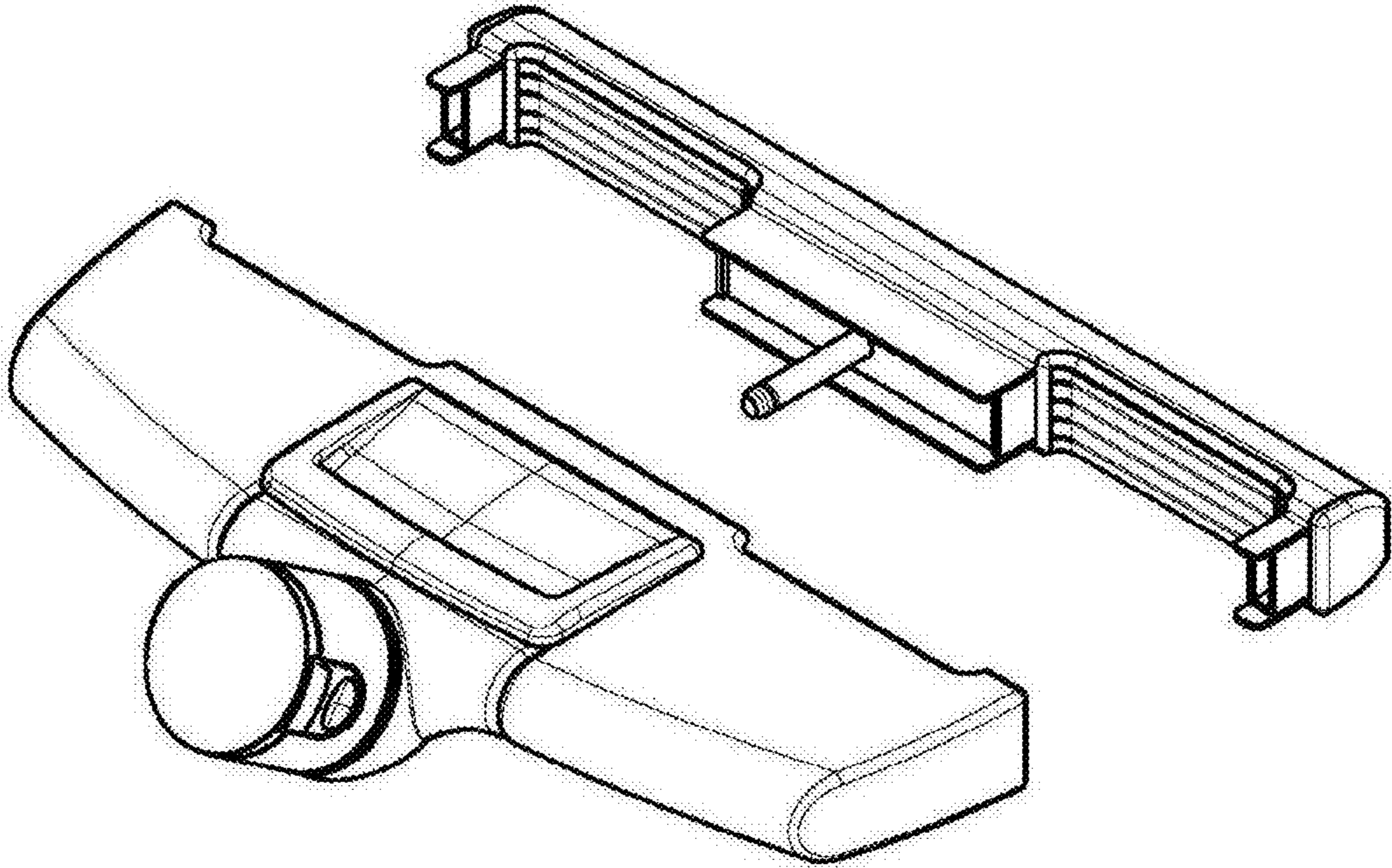

Fig. 1

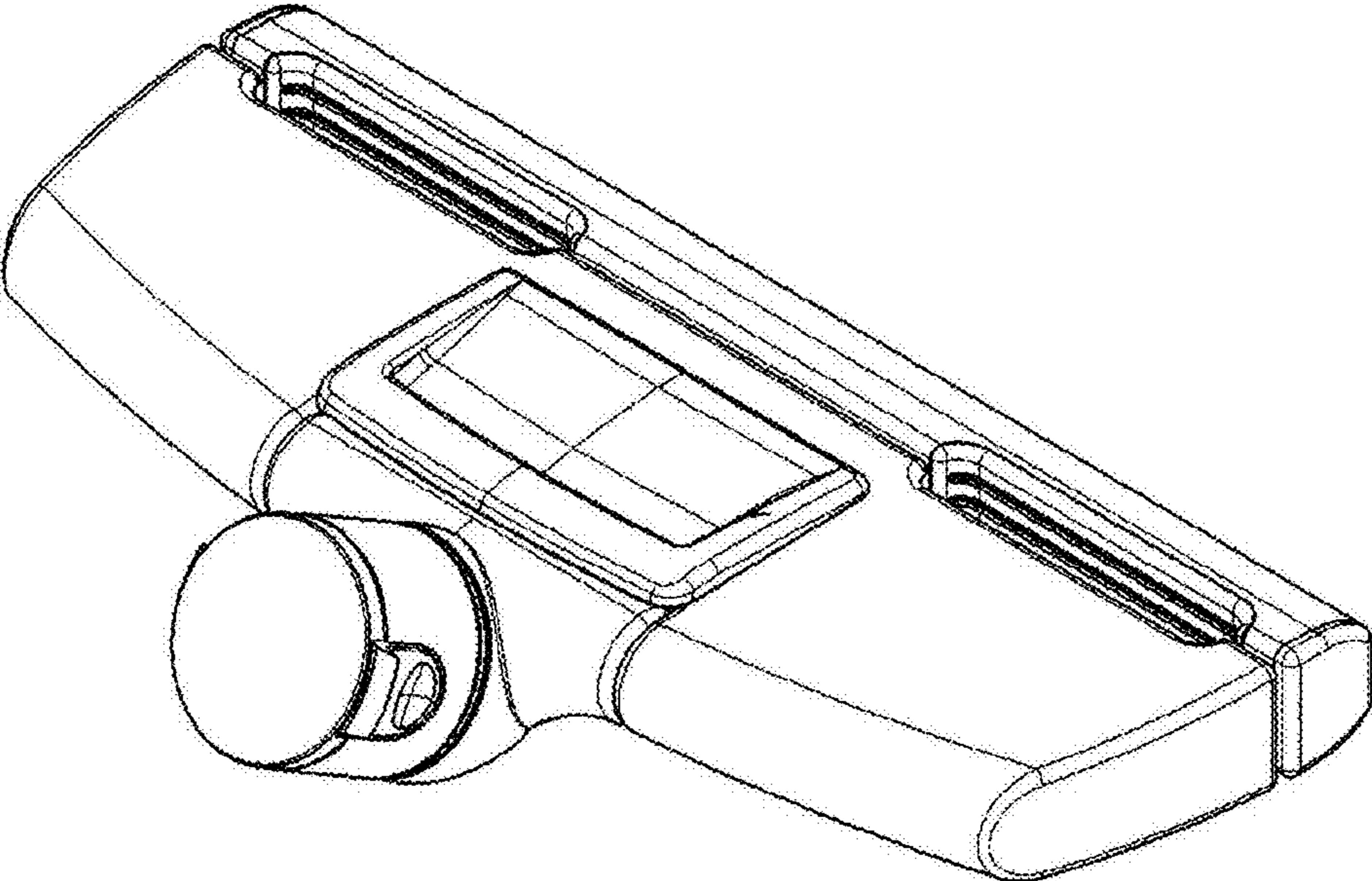

Fig. 2

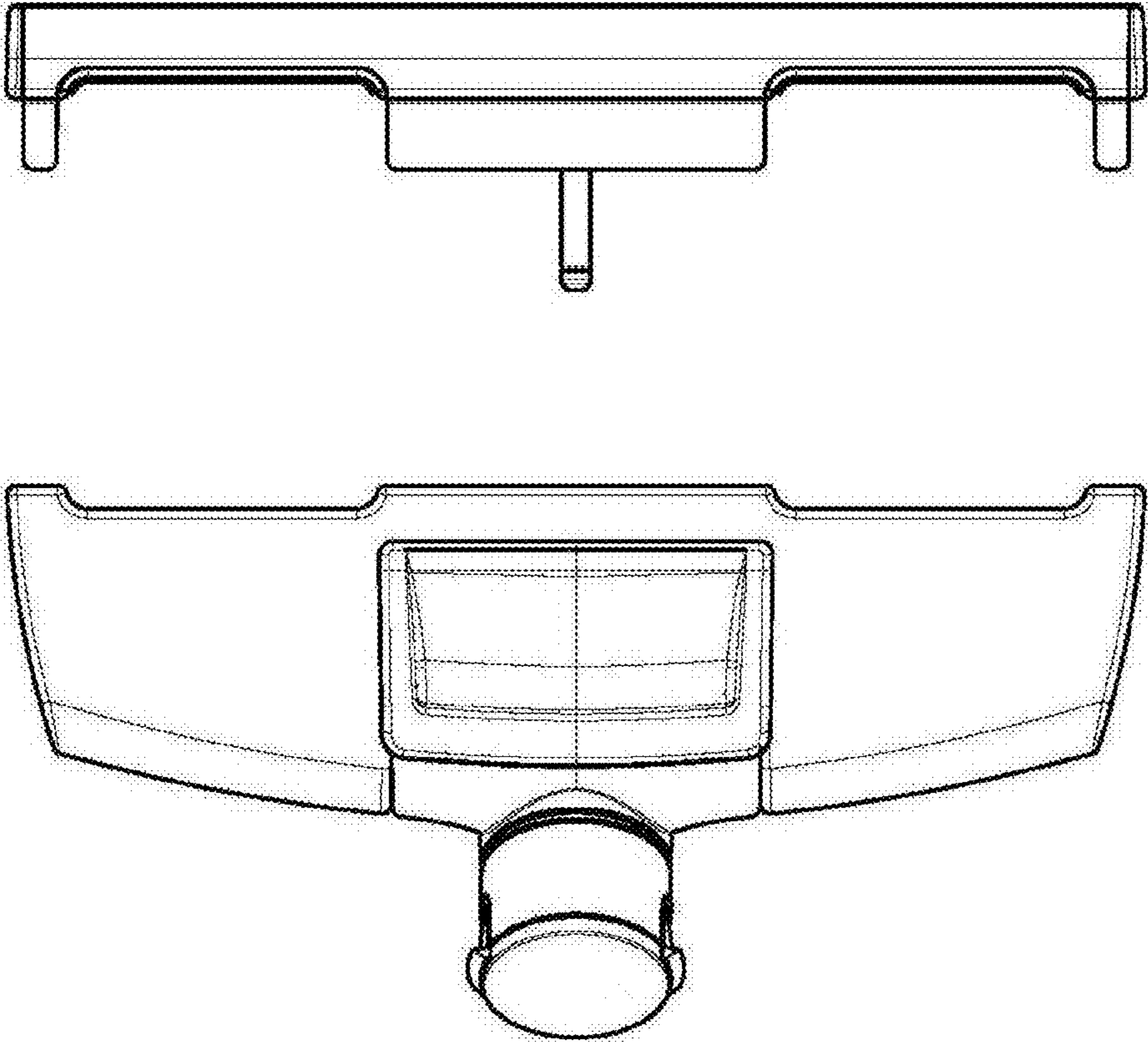

Fig. 3

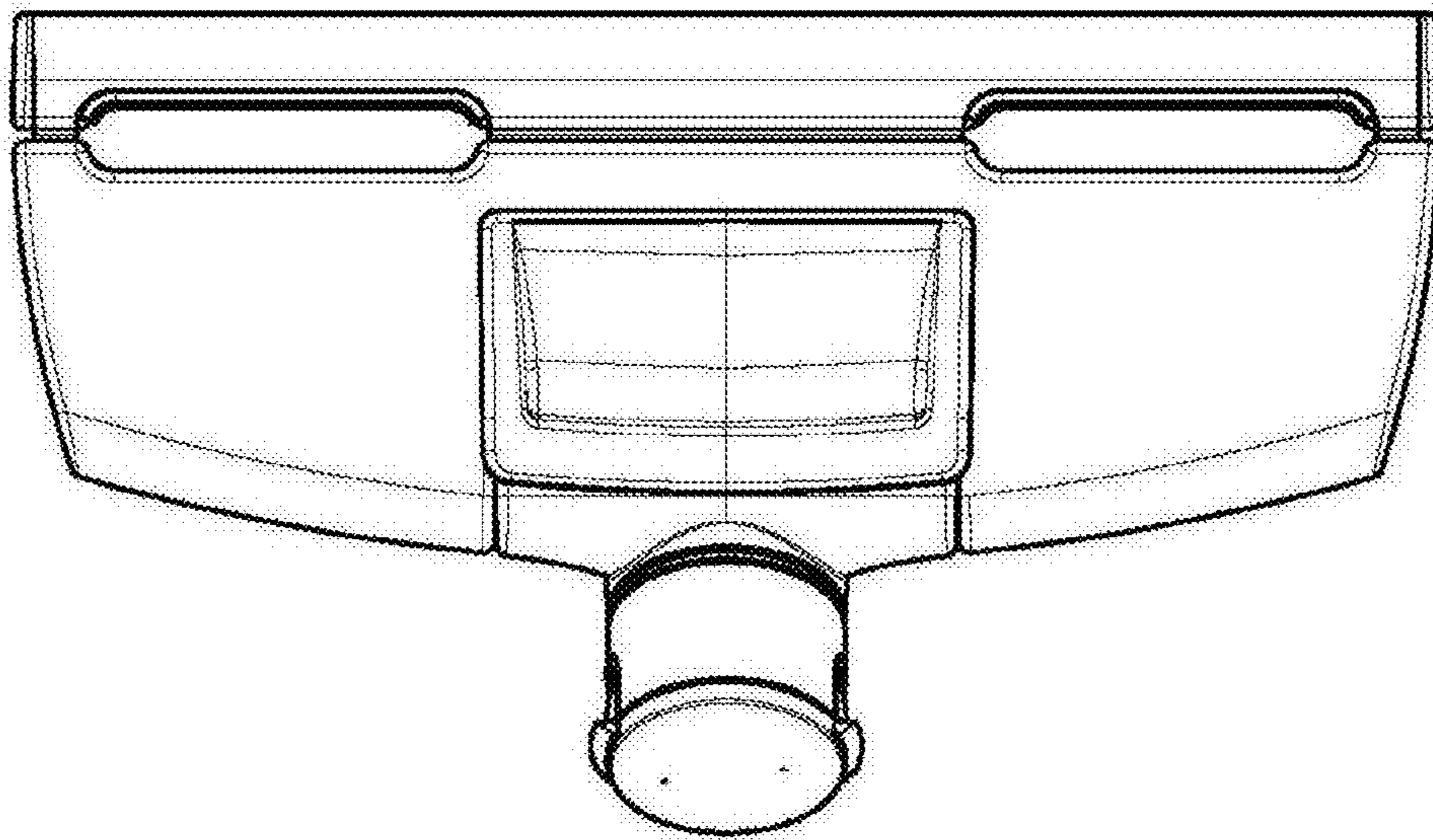

Fig. 4

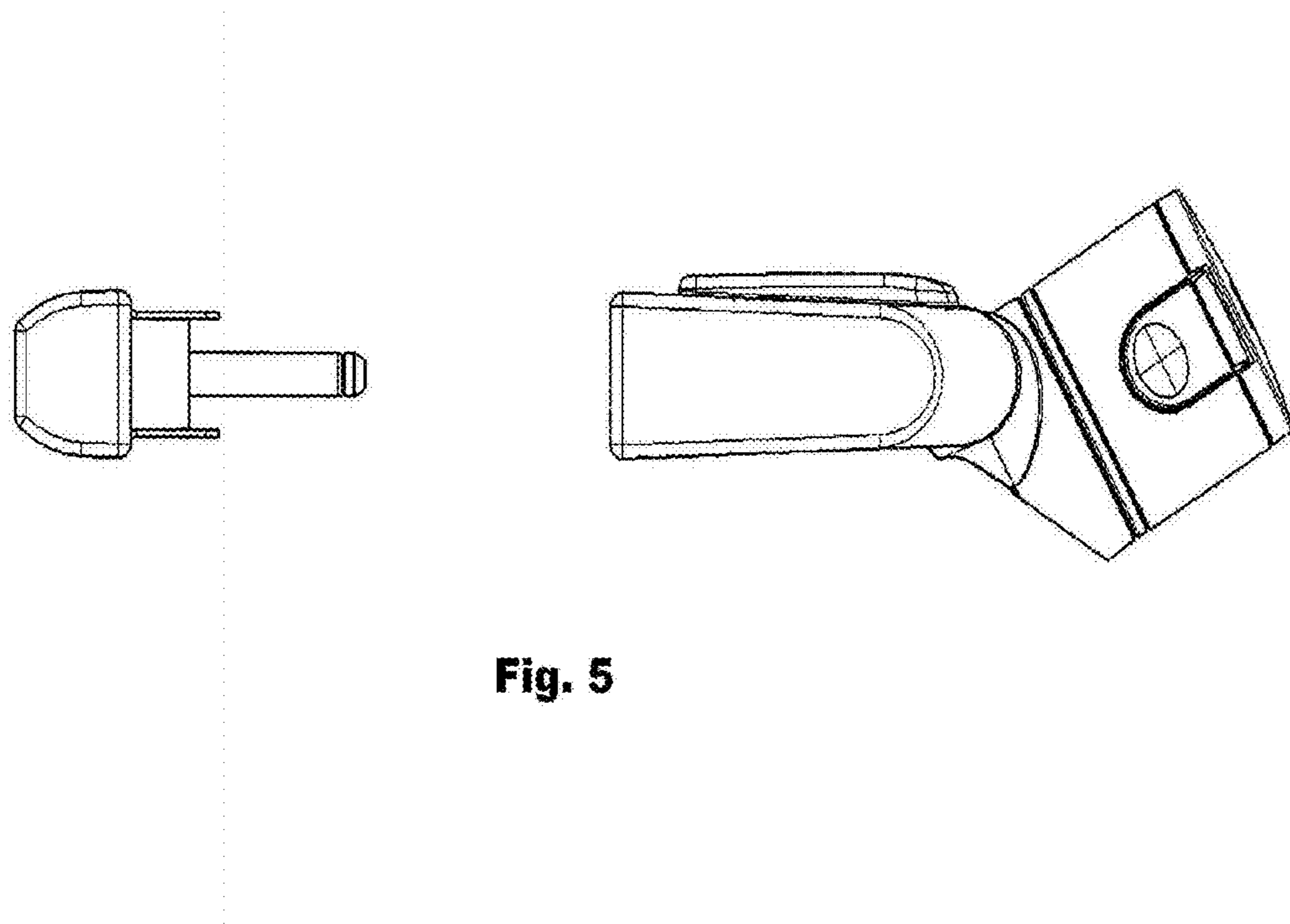

Fig. 5

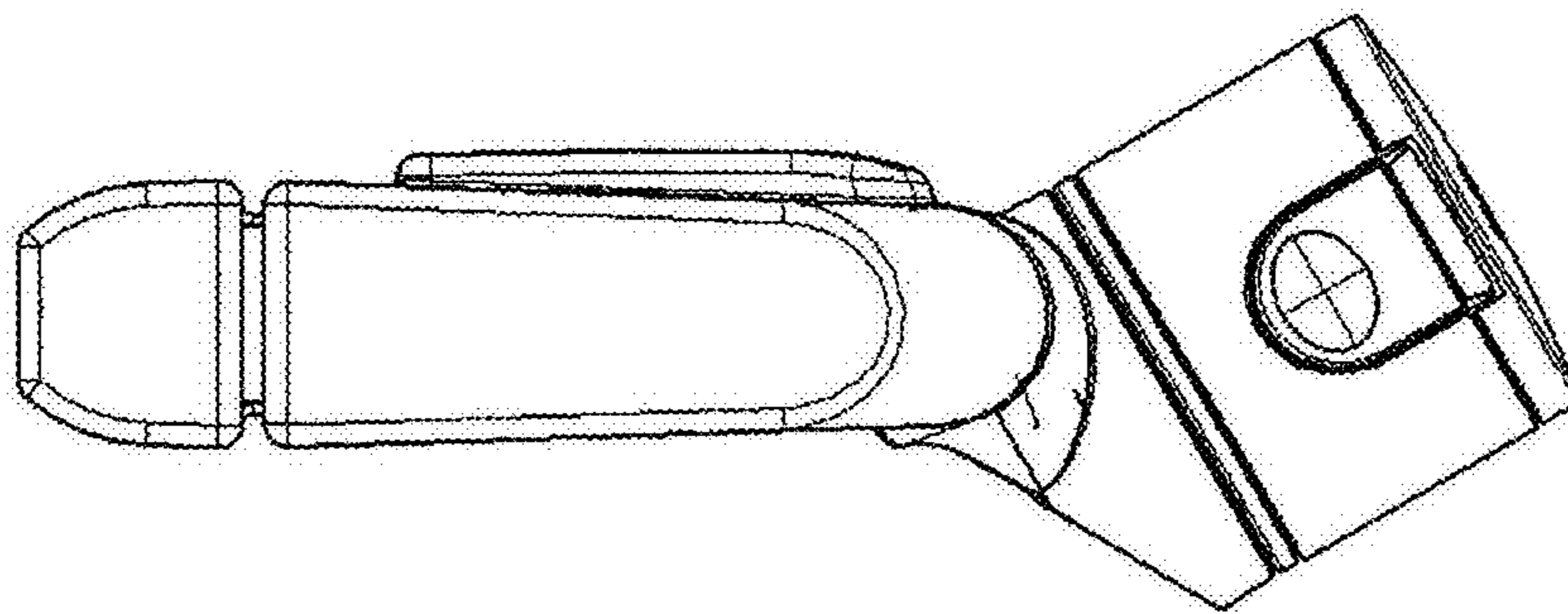

Fig. 6

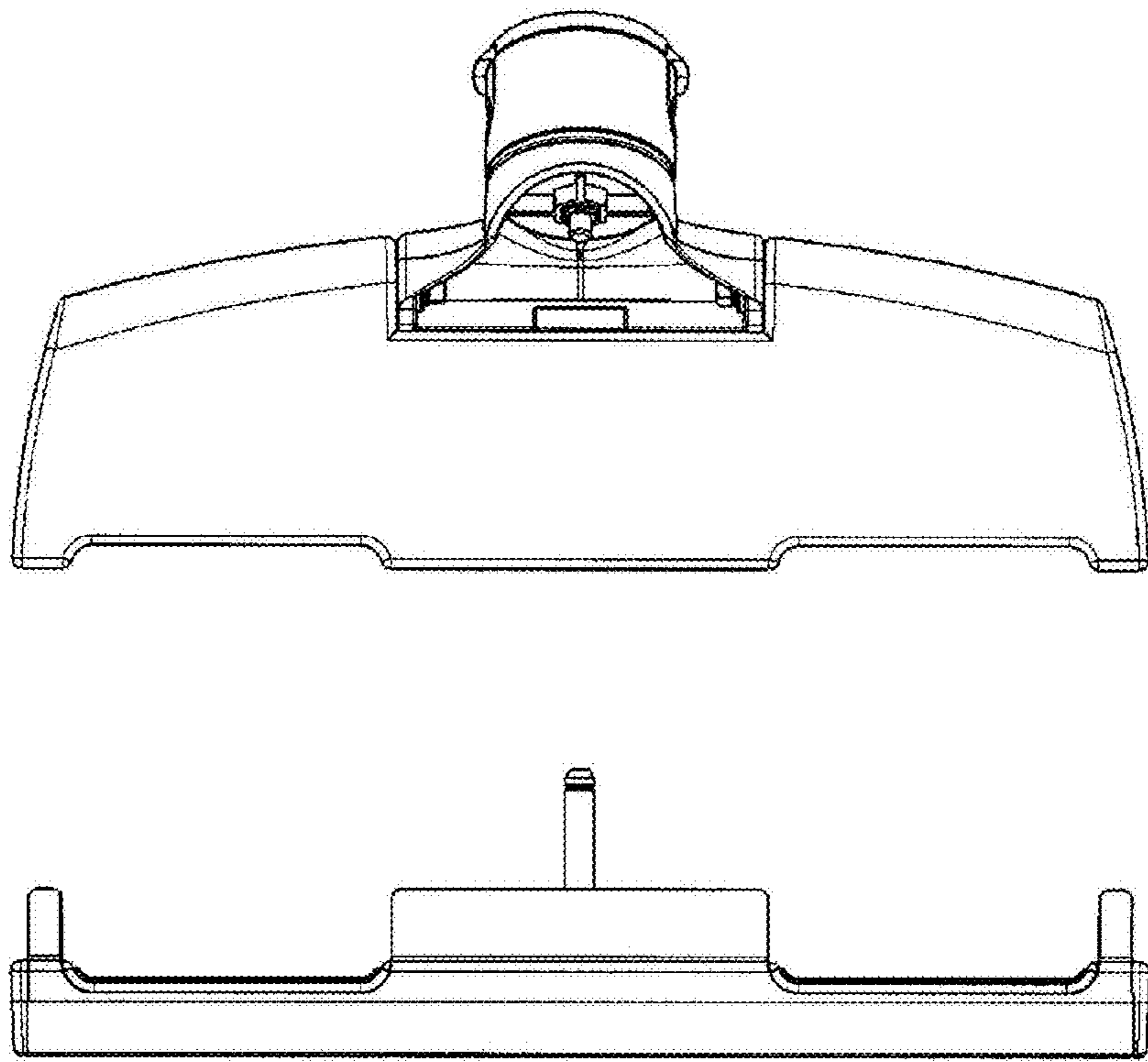

Fig. 7

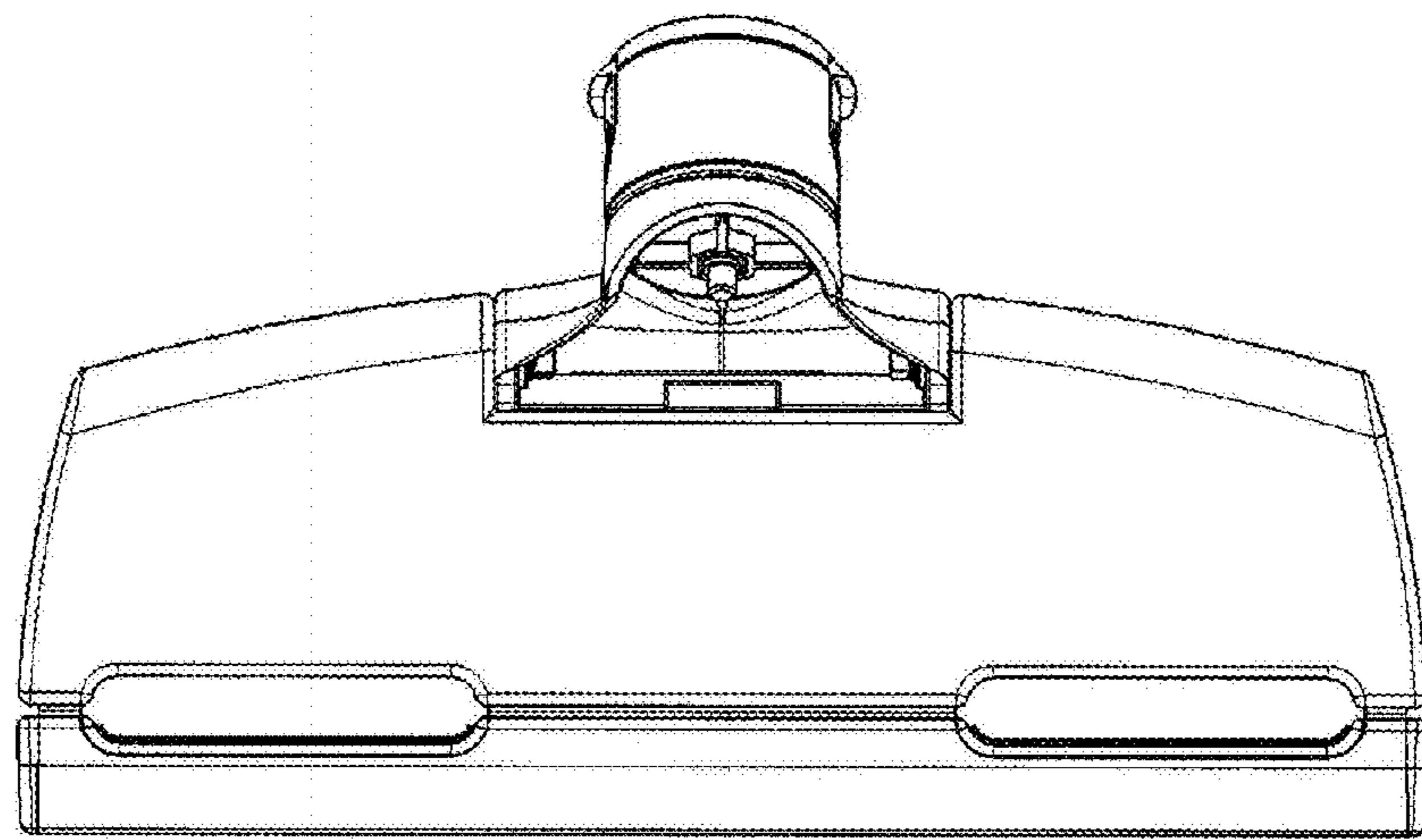

Fig. 8

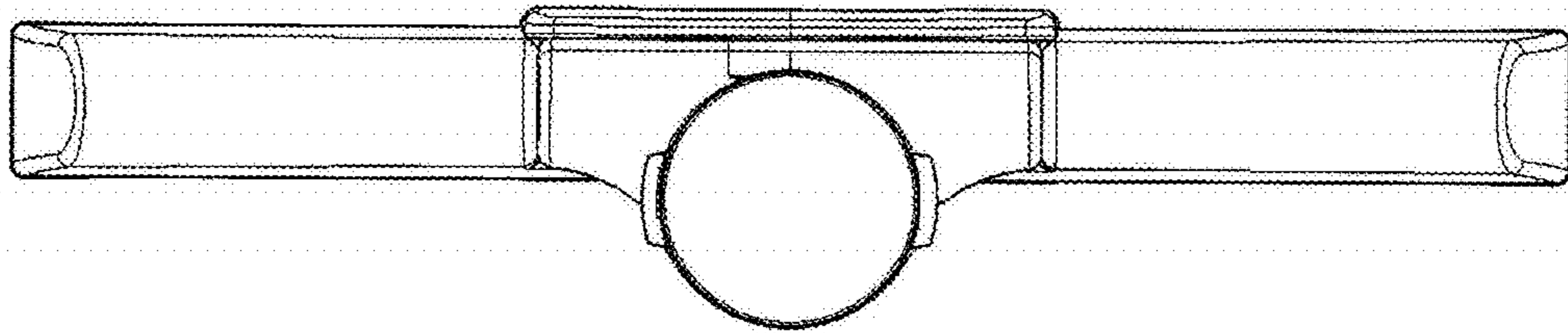

Fig. 9

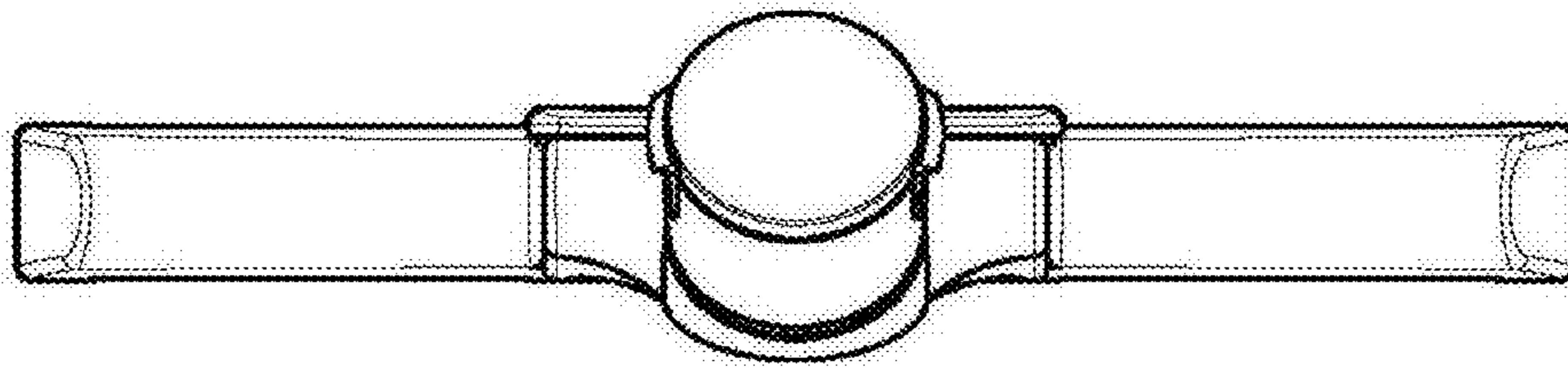

Fig. 10

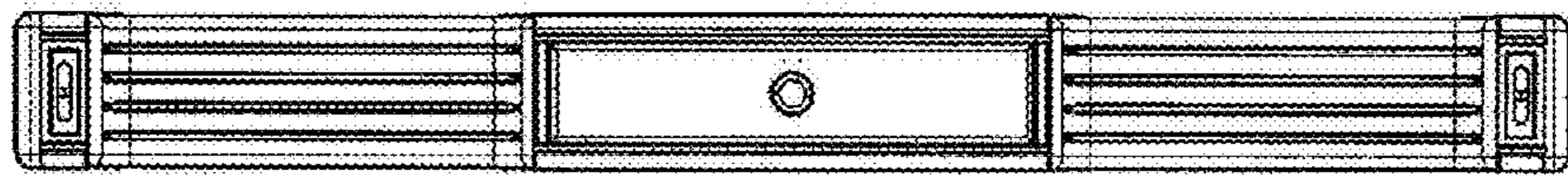

Fig. 11

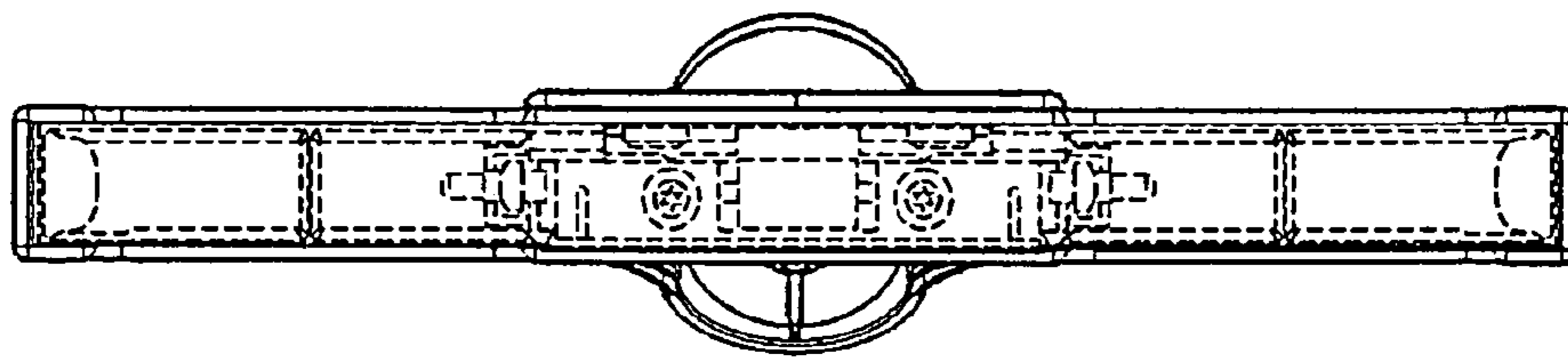

Fig. 12

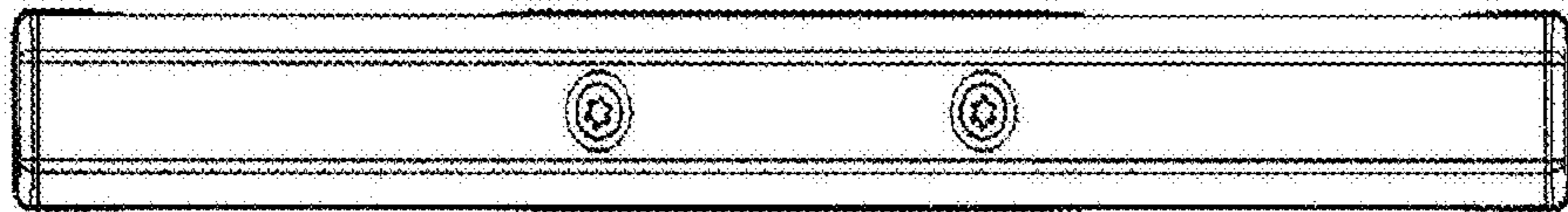

Fig. 13

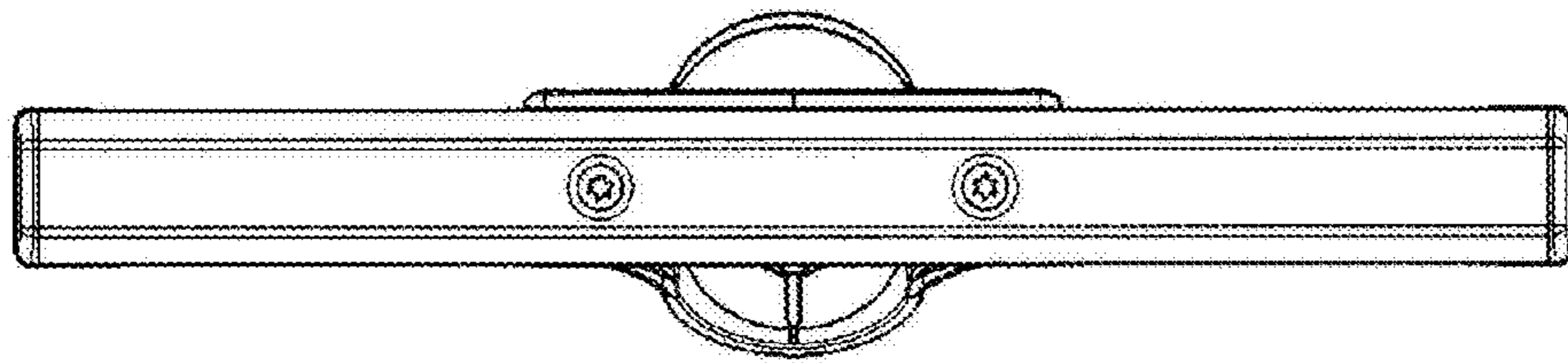

Fig. 14