



US00D692803S

(12) **United States Design Patent**
Nakahara

(10) **Patent No.:** **US D692,803 S**
(45) **Date of Patent:** **** Nov. 5, 2013**

(54) **FRONT GRILLE FOR AUTOMOBILES**

(75) Inventor: **Jun Nakahara**, Wako (JP)

(73) Assignee: **Honda Motor Co., Ltd**, Tokyo (JP)

(**) Term: **14 Years**

(21) Appl. No.: **29/407,144**

(22) Filed: **Nov. 23, 2011**

(30) **Foreign Application Priority Data**

May 24, 2011 (JP) 2011-011624

(51) **LOC (9) Cl.** **12-16**

(52) **U.S. Cl.**
USPC **D12/163**

(58) **Field of Classification Search**
USPC D12/86, 90, 91, 92, 163, 169, 196, 171,
D12/216; 180/68.1, 68.6; 296/193.11
See application file for complete search history.

(56) **References Cited**

U.S. PATENT DOCUMENTS

| | | | |
|--------------|---------|-----------------------|---------|
| D475,662 S * | 6/2003 | Koizumi et al. | D12/163 |
| D557,184 S * | 12/2007 | Janik | D12/163 |
| D573,924 S * | 7/2008 | Tachibana | D12/163 |
| D584,198 S * | 1/2009 | Tamura | D12/163 |
| D589,853 S * | 4/2009 | Saridakis et al. | D12/163 |
| D592,564 S * | 5/2009 | Kusamoto et al. | D12/163 |

| | | | |
|--------------|---------|-------------------|---------|
| D610,052 S * | 2/2010 | Watanabe | D12/163 |
| D624,469 S * | 9/2010 | Miyazawa | D12/163 |
| D635,065 S * | 3/2011 | Seo | D12/163 |
| D651,142 S * | 12/2011 | Fushimi | D12/163 |
| D665,313 S * | 8/2012 | Asakura | D12/163 |
| D668,590 S * | 10/2012 | Furst et al. | D12/163 |
| D670,620 S * | 11/2012 | Frei et al. | D12/163 |

* cited by examiner

Primary Examiner — Philip S Hyder

Assistant Examiner — Darlington Ly

(74) *Attorney, Agent, or Firm* — Westerman, Hattori,
Daniels & Adrian, LLP

(57) **CLAIM**

The ornamental design for a front grille for automobiles, as shown and described.

DESCRIPTION

FIG. 1 is a front elevational view of a front grille for automobiles showing my new design;
FIG. 2 is a top plan view thereof;
FIG. 3 is a right side elevational view thereof, the left side elevational view being a mirror image thereof;
FIG. 4 is perspective view of the left front side thereof; and,
FIG. 5 is a reference view thereof, showing an enlarged portion of the grille of FIG. 4.

The vertical and curvilinear broken lines shown in FIG. 5 indicate cutaway portions of the front grille for automobiles; all other broken lines represent environmental structure only and form no part of the claimed design.

1 Claim, 3 Drawing Sheets

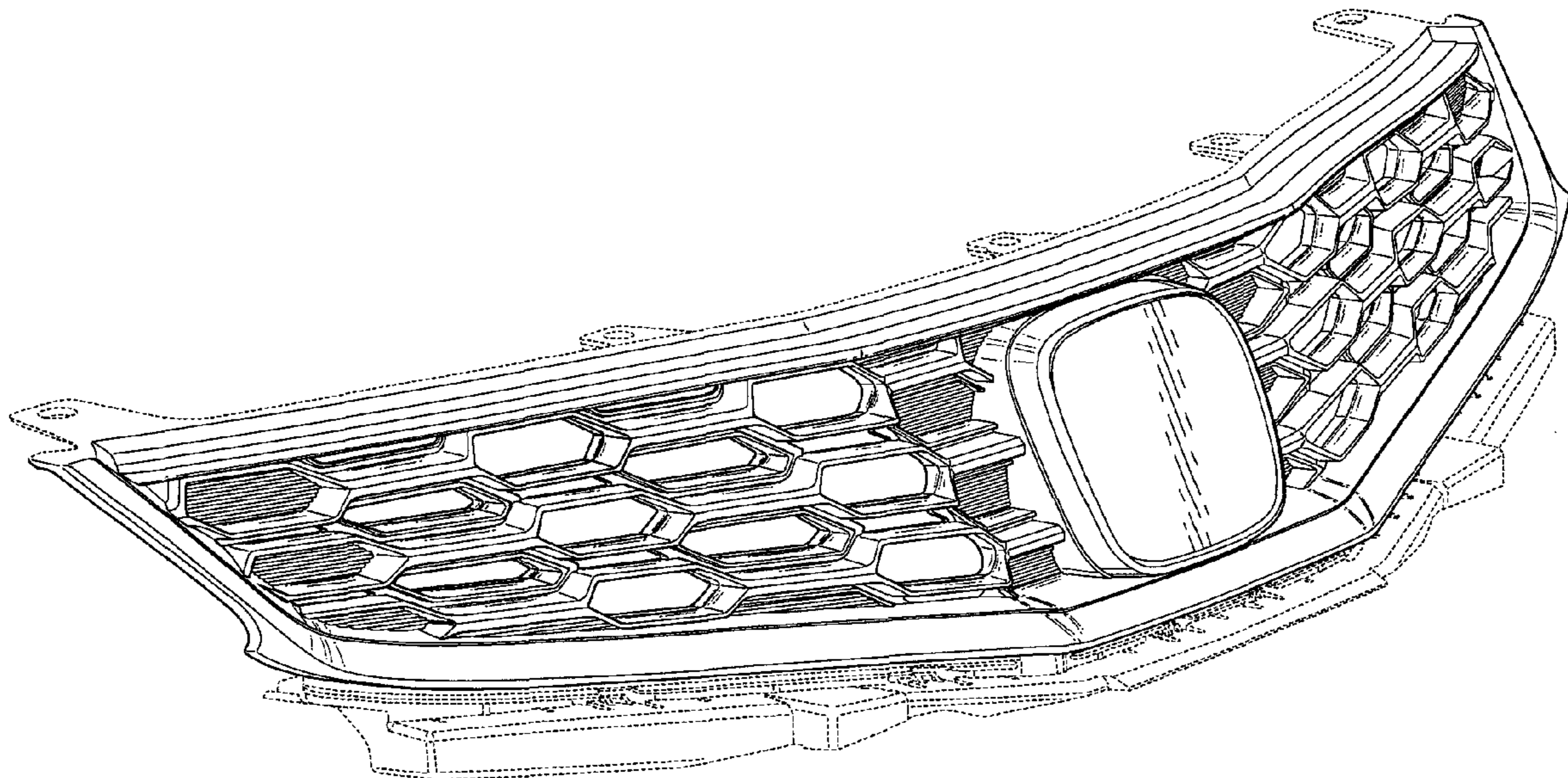

FIG.1

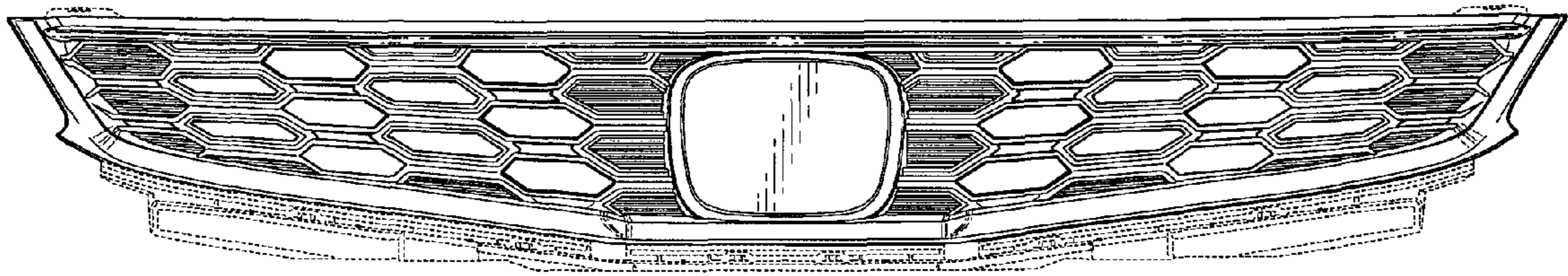

FIG.2

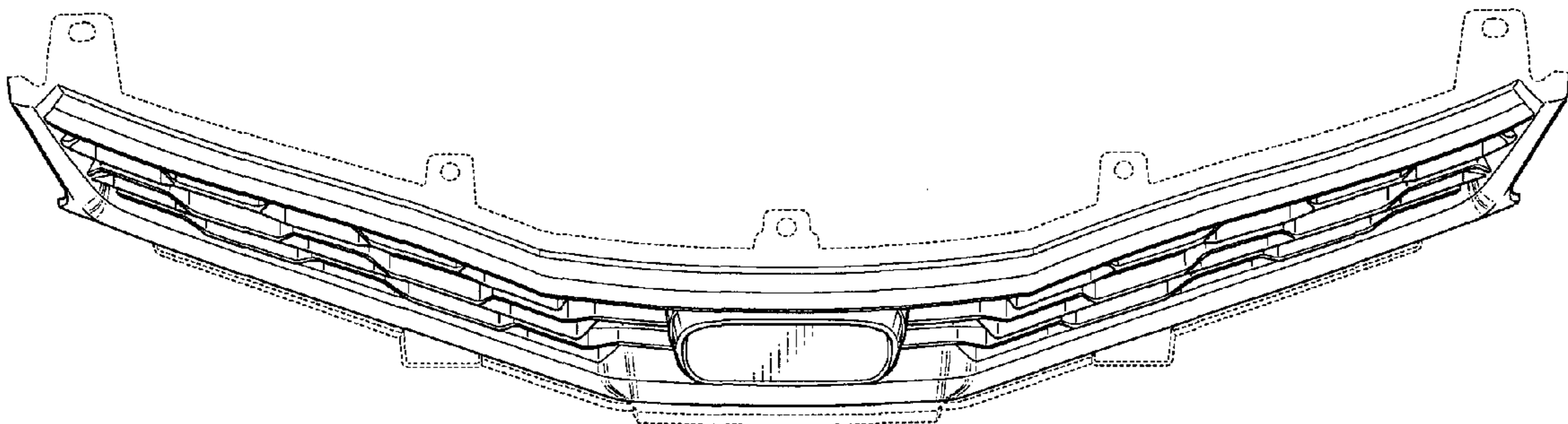

FIG.3

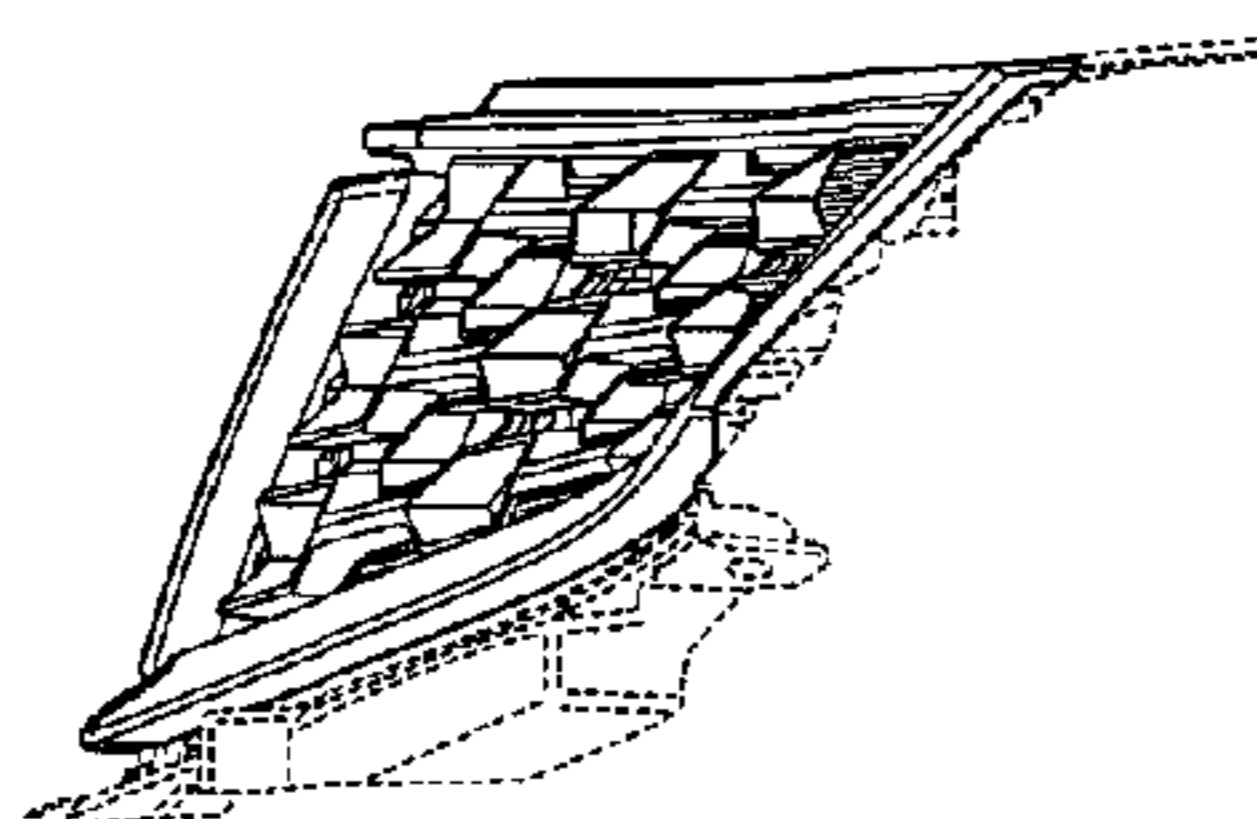

FIG.4

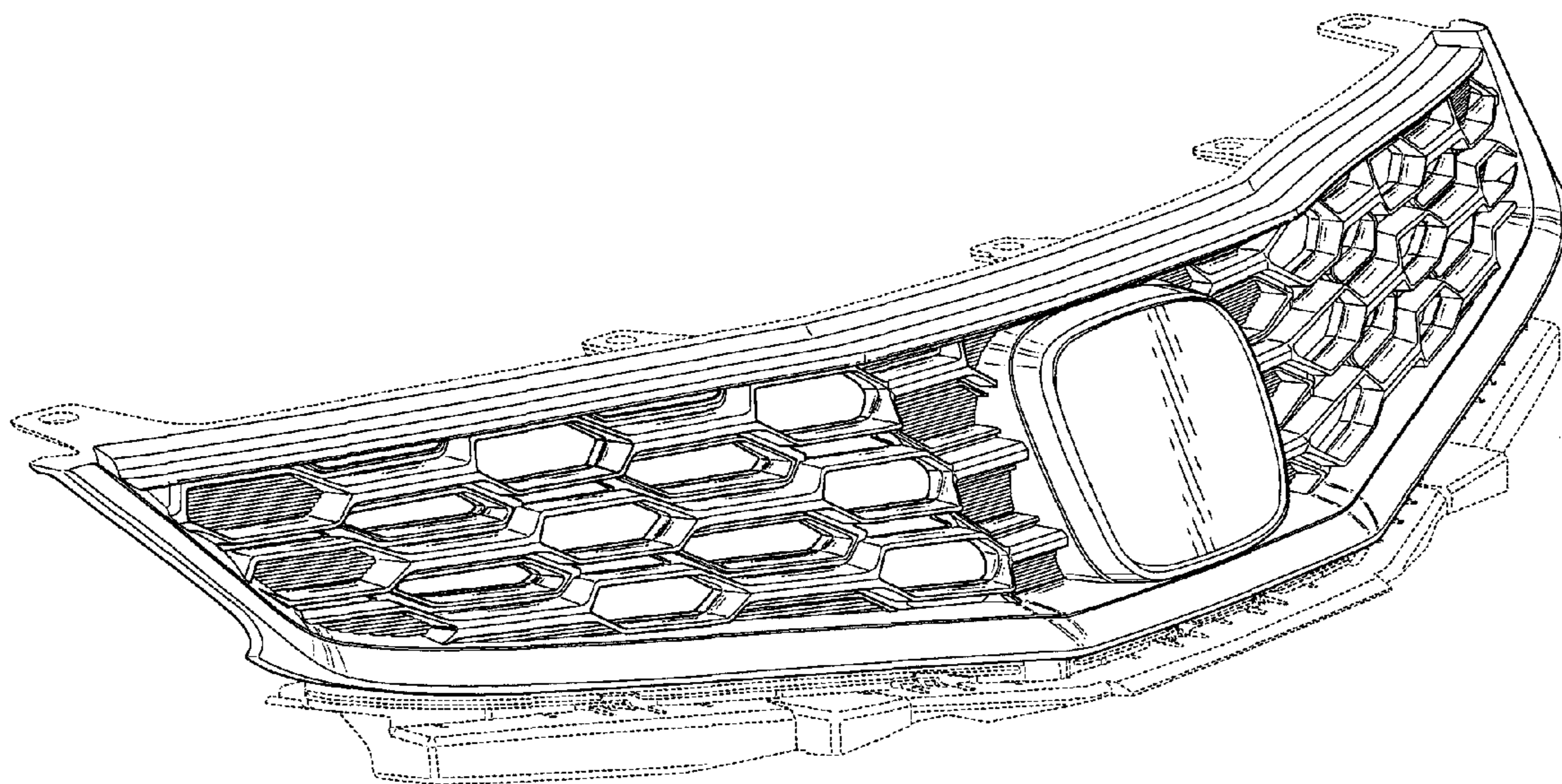

FIG.5

