

US00D692799S

(12) **United States Design Patent**
Smith et al.

(10) **Patent No.:** **US D692,799 S**
(45) **Date of Patent:** **** Nov. 5, 2013**

(54) **VEHICLE BODY**

(75) Inventors: **Andrew D Smith**, Seoul (KR); **Hoe Young Hwang**, Seoul (KR)

(73) Assignee: **GM Global Technology Operations LLC**, Detroit, MI (US)

(**) Term: **14 Years**

(21) Appl. No.: **29/417,143**

(22) Filed: **Mar. 30, 2012**

(51) **LOC (9) Cl.** **12-08**

(52) **U.S. Cl.**
USPC **D12/92**

(58) **Field of Classification Search**
USPC D12/86, 90-92; D21/424, 433, 434;
296/181.1, 181.5

See application file for complete search history.

(56) **References Cited**

U.S. PATENT DOCUMENTS

D592,105 S	5/2009	Dean et al.	
D597,447 S	8/2009	Folden	
D603,755 S	11/2009	Peters	
D605,082 S	12/2009	Munson	
D605,083 S	12/2009	Manoogian, II et al.	
D608,249 S	1/2010	Peters	
D609,608 S	2/2010	Boniface et al.	
D611,387 S	3/2010	Thompson et al.	
D611,879 S	3/2010	Kim et al.	
D612,297 S	3/2010	Peters et al.	
D615,458 S	5/2010	Thompson et al.	
D623,090 S	9/2010	Cox et al.	
D644,567 S	9/2011	Kozub	
D664,475 S *	7/2012	Takahashi	D12/92
D670,202 S *	11/2012	Blasi	D12/92
D670,203 S *	11/2012	Weil	D12/92

OTHER PUBLICATIONS

Design U.S. Appl. No. 29/392,615, filed May 24, 2011; First Named Inventor: Carlos M. Barba Franco; Title: Vehicle Body.
 Design U.S. Appl. No. 29/407,580, filed Nov. 30, 2011; First Named Inventor: Robert J. Munson; Title: Vehicle Body.
 Design U.S. Appl. No. 29/409,092, filed Dec. 20, 2011; First Named Inventor: Nicholas J. David; Title: Vehicle Body.
 Design U.S. Appl. No. 29/413,221, filed Feb. 13, 2012; First Named Inventor: Joseph C. Baker; Title: Vehicle Body.
 Design U.S. Appl. No. 29/414,260, filed Feb. 27, 2012; First Named Inventor: Steven M. McCabe; Title: Vehicle Body.
 Design U.S. Appl. No. 29/416,870, filed Mar. 28, 2012; First Named Inventor: Joshua L. Thurber; Title: Vehicle Body.
 Design U.S. Appl. No. 29/403,440, filed Oct. 6, 2011; First Named Inventor: Niki J. Smart; Title: Vehicle Body.

* cited by examiner

Primary Examiner — Melody Brown

(74) *Attorney, Agent, or Firm* — Reising Ethington PC; Lionel D. Anderson

(57) **CLAIM**

The ornamental design for a vehicle body, as shown and described.

DESCRIPTION

FIG. 1 is a front perspective view of a vehicle body;
 FIG. 2 is a front view of the vehicle body;
 FIG. 3 is a right side view of the vehicle body;
 FIG. 4 is a left side view of the vehicle body;
 FIG. 5 is a top view of the vehicle body;
 FIG. 6 is a rear perspective view of the vehicle body; and,
 FIG. 7 is a rear view of the vehicle body.
 In the drawings, the portions shown by broken lines form no part of the claimed design.

1 Claim, 7 Drawing Sheets

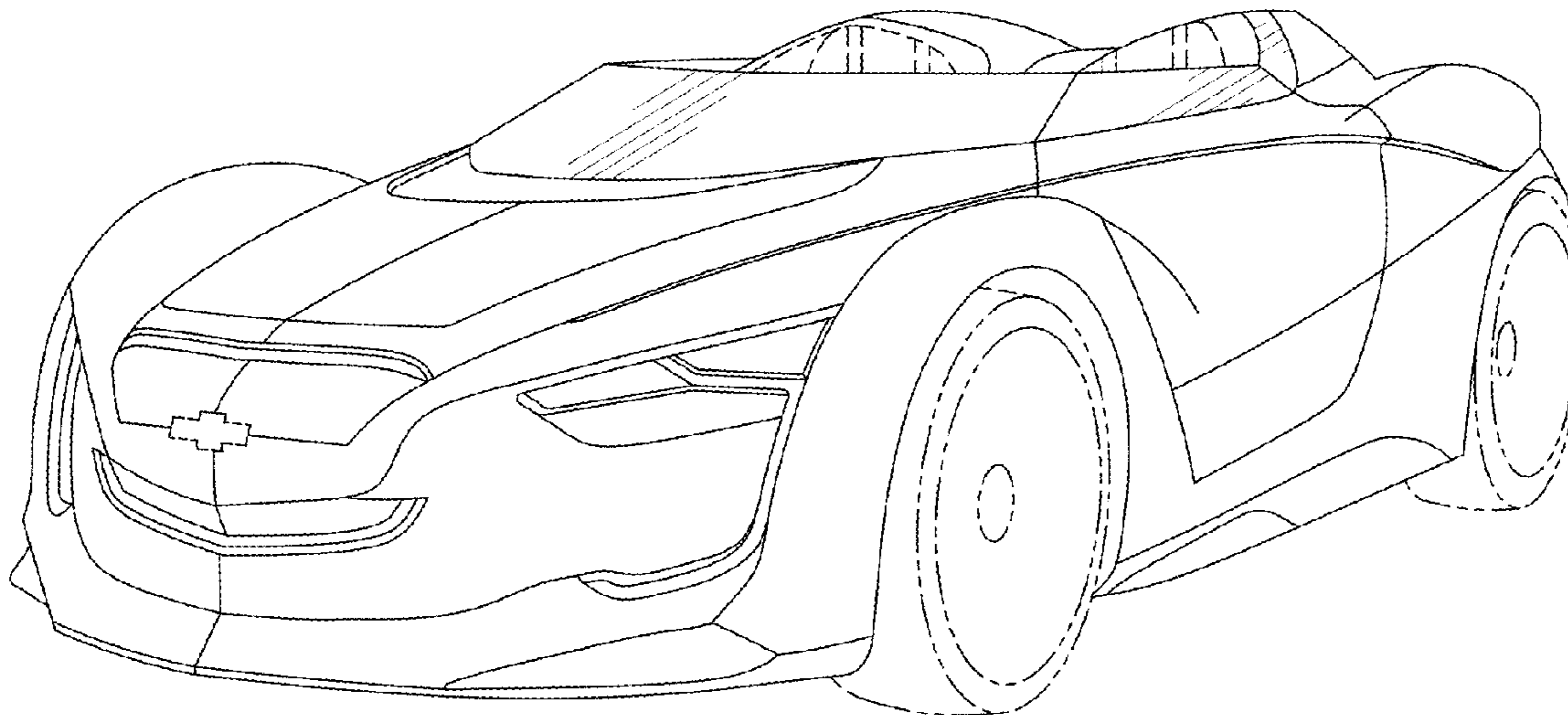

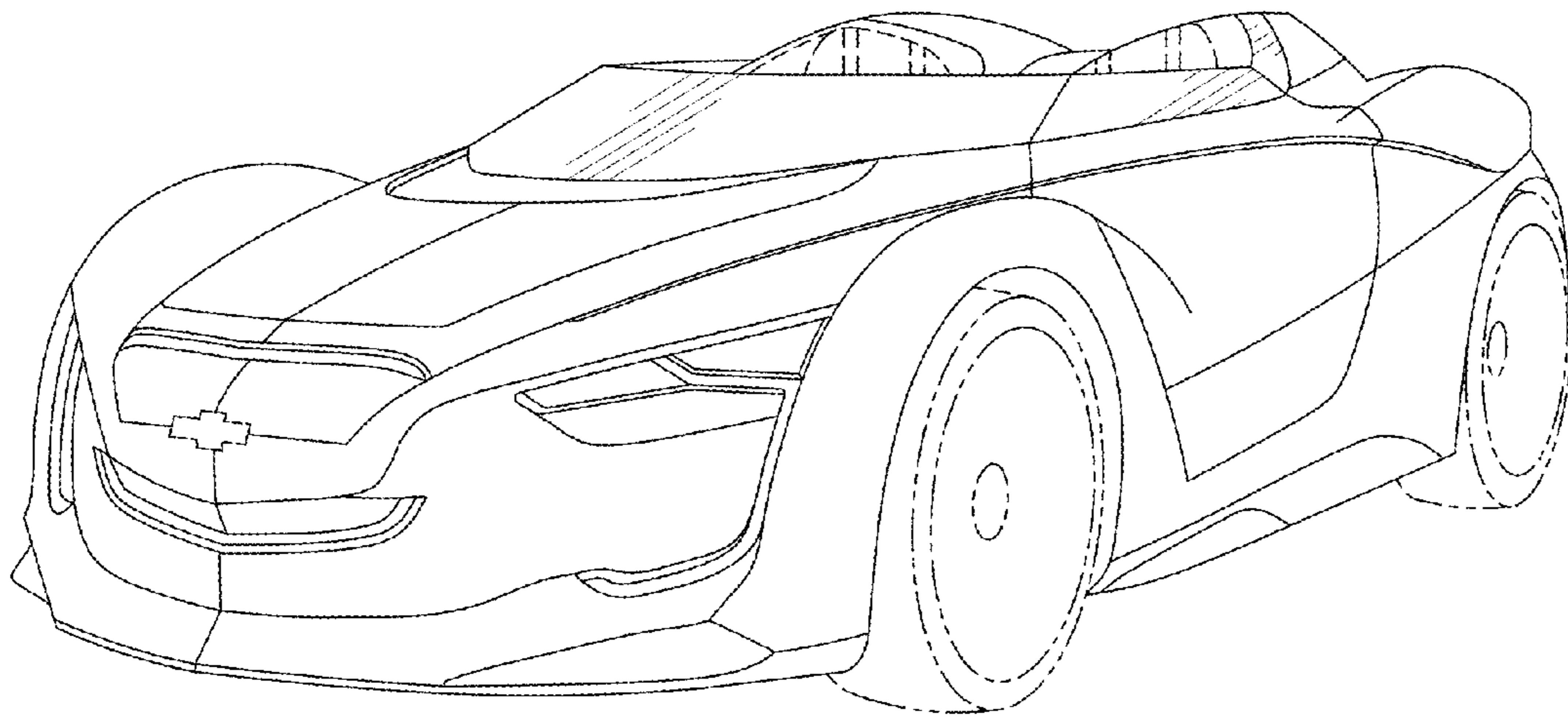

Fig-1

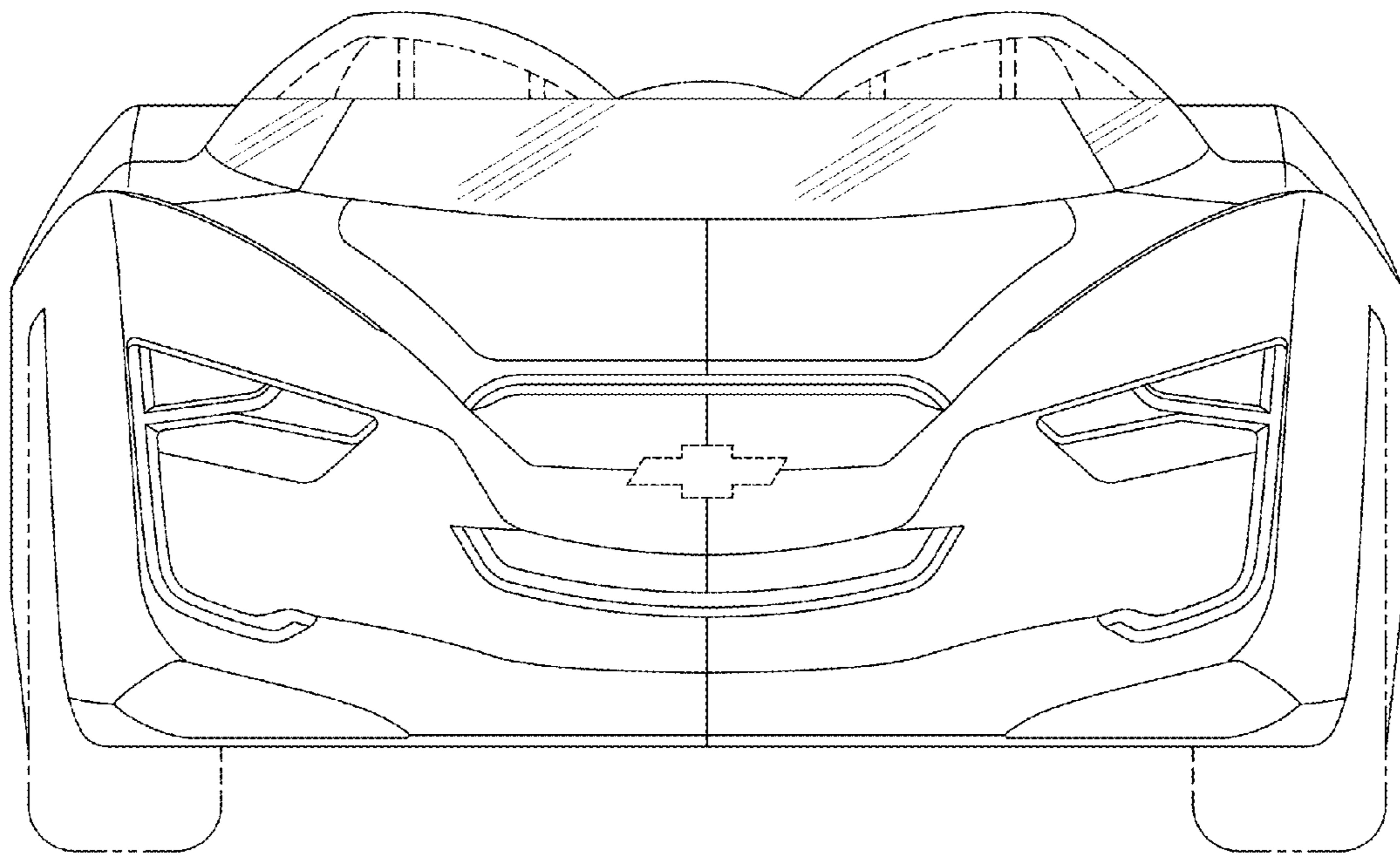

Fig-2

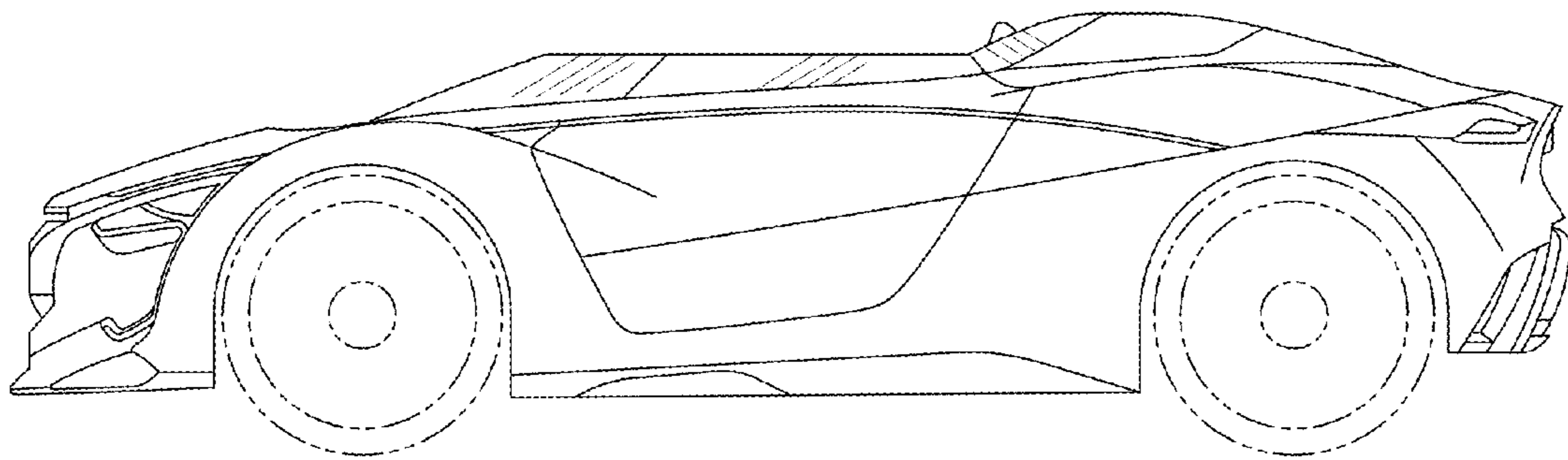

Fig-3

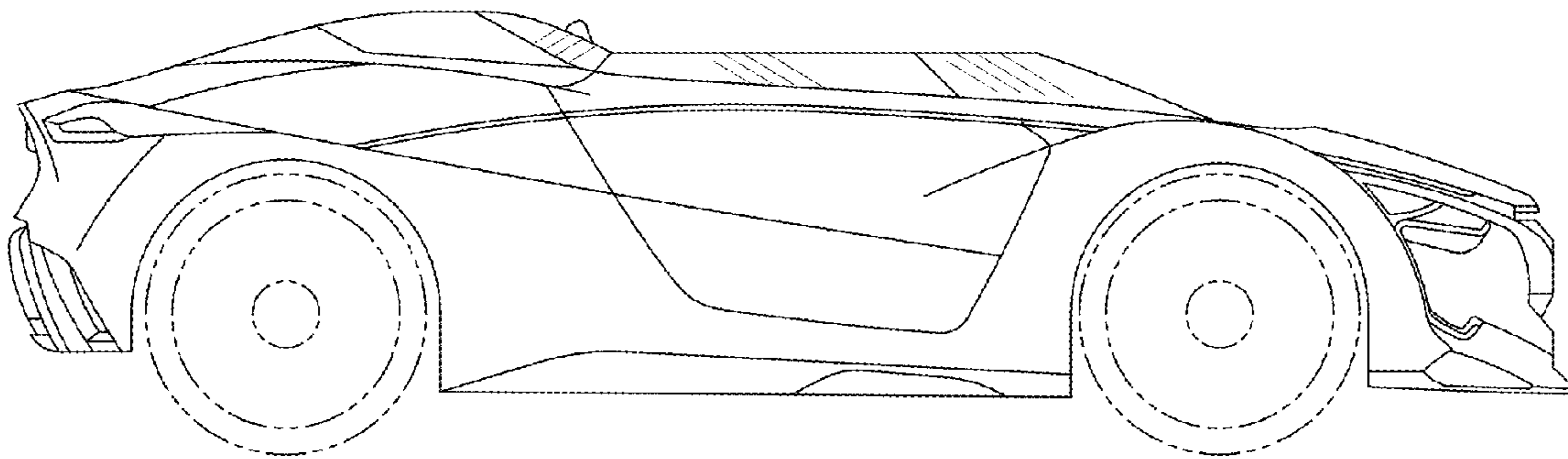

Fig-4

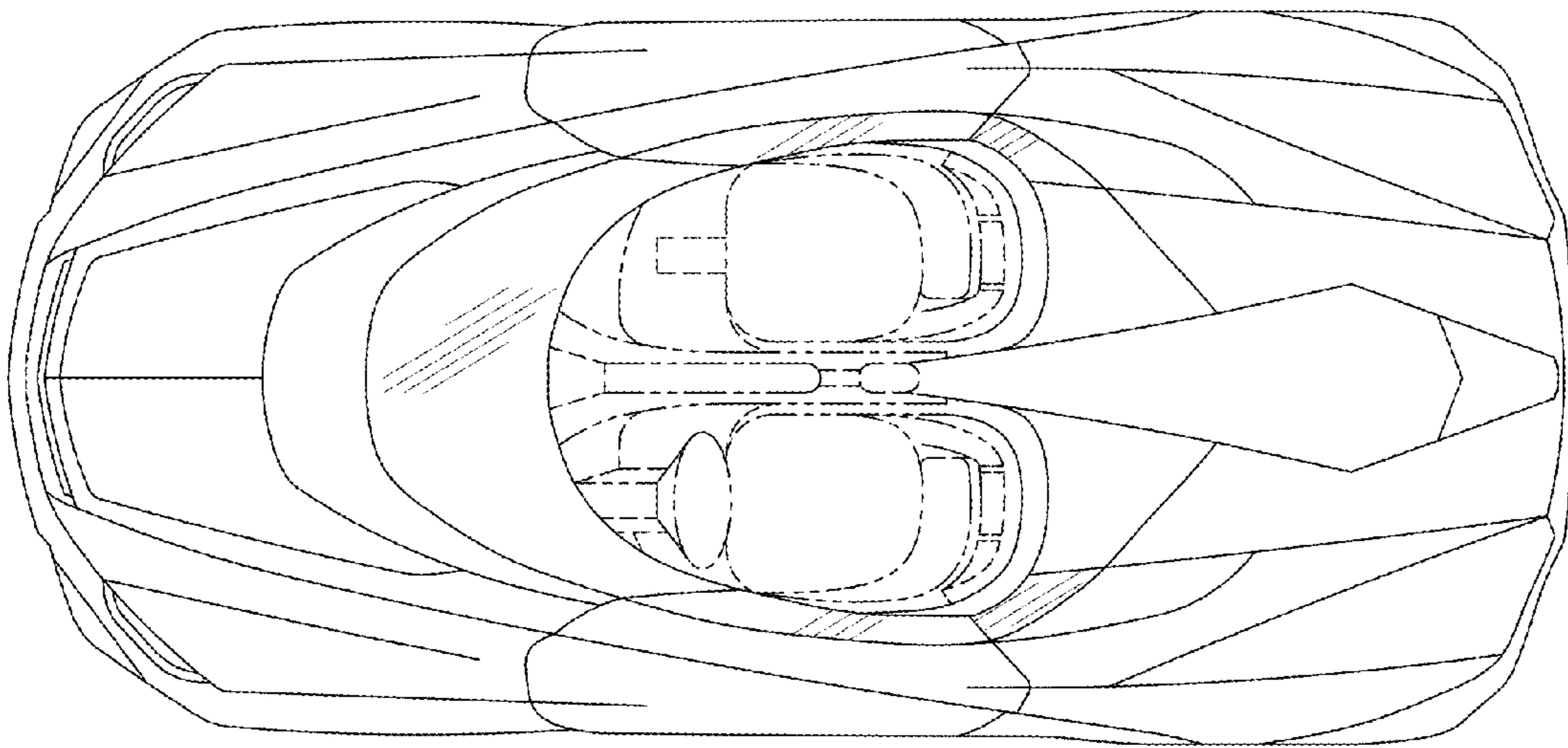

Fig-5

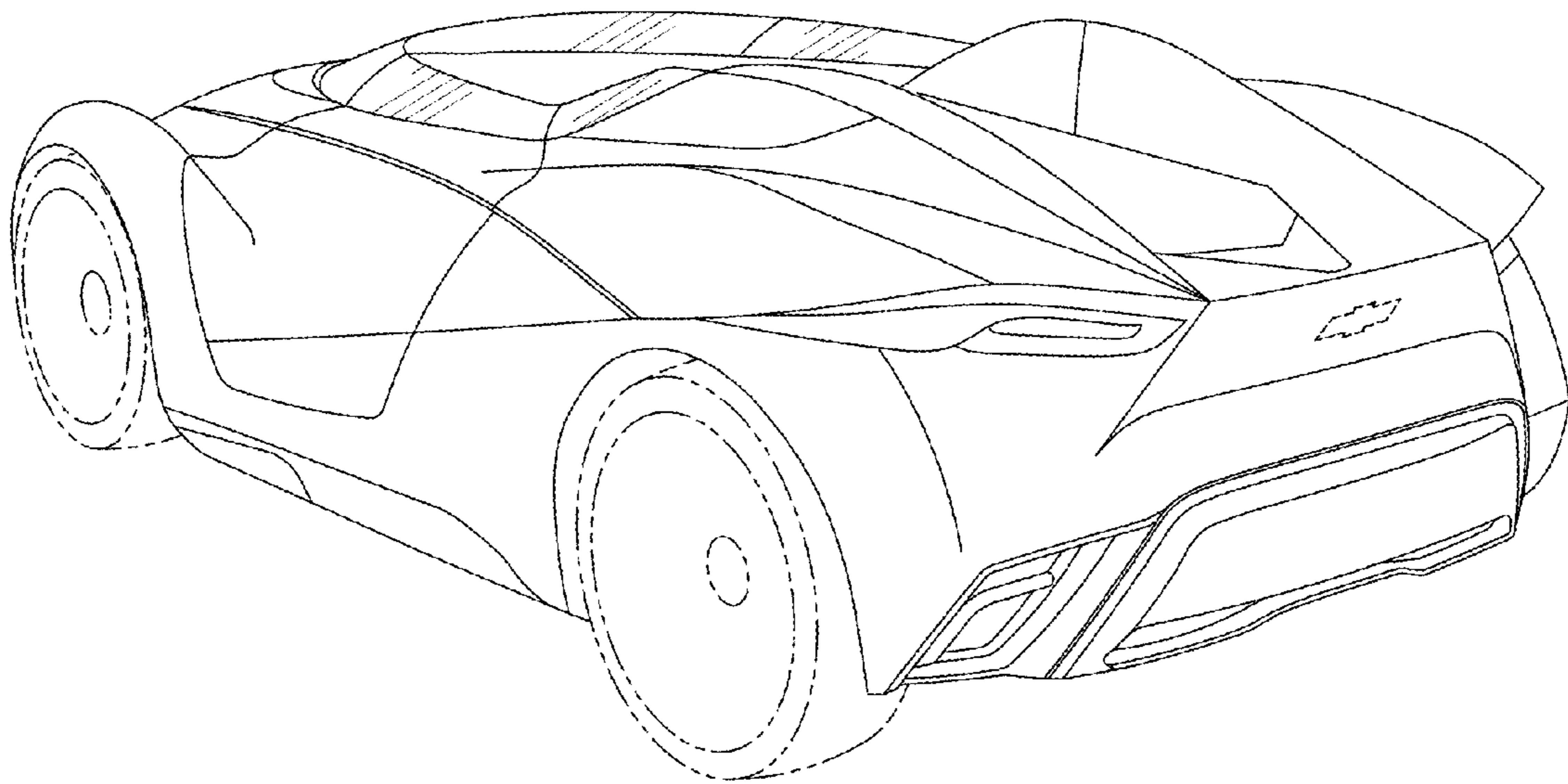

Fig-6

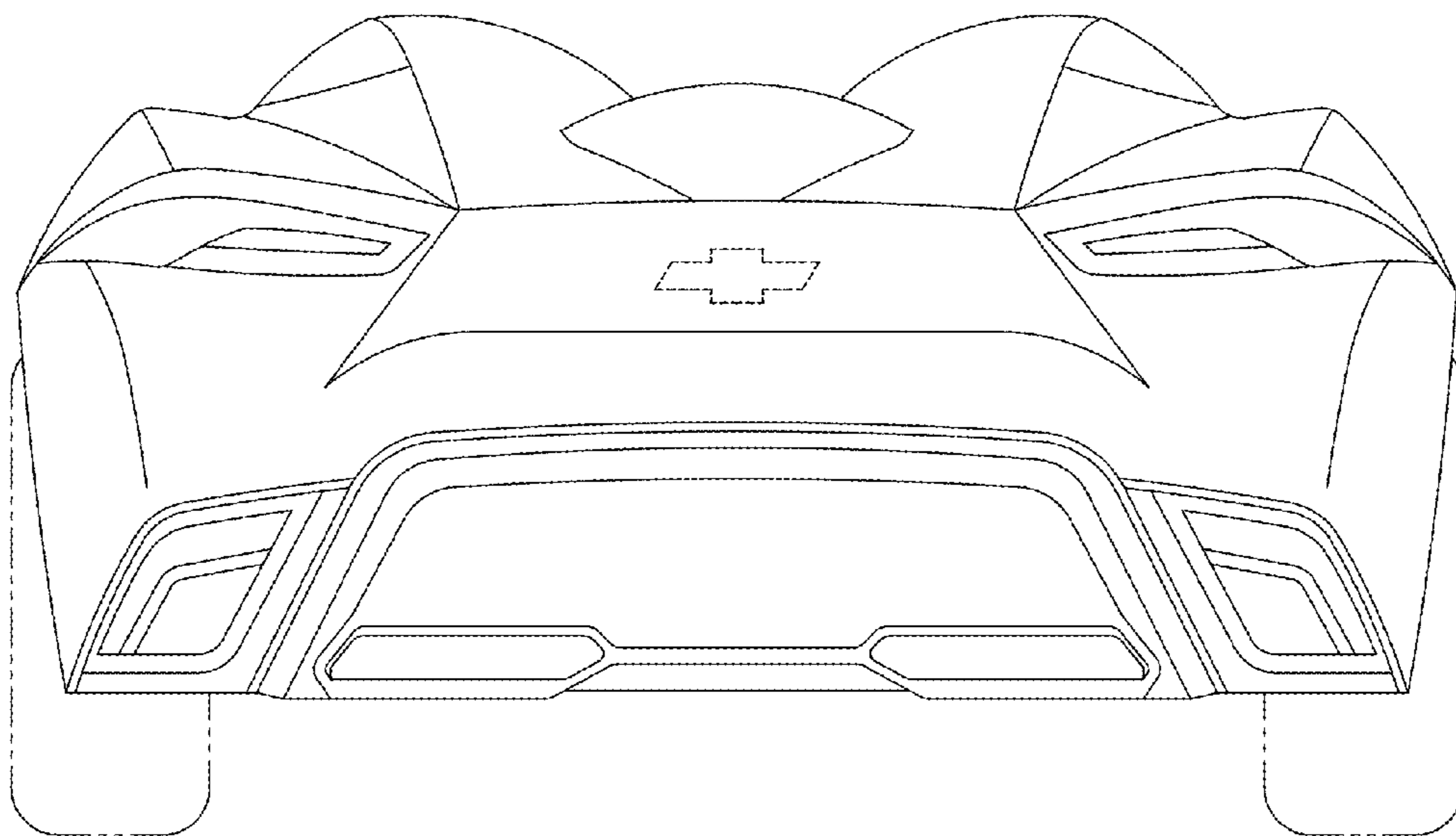

Fig-7