

US00D692486S

(12) **United States Design Patent**
Casciotti et al.

(10) **Patent No.:** **US D692,486 S**
(45) **Date of Patent:** **** Oct. 29, 2013**

(54) **WRITING INSTRUMENT**
(75) Inventors: **David M. Casciotti**, Amsterdam, NY
(US); **Jing Mahler**, Glenville, NY (US)
(73) Assignee: **Holland USA, Inc.**, North Mankato, MN
(US)

D372,048 S 7/1996 Hollington
D375,124 S 10/1996 Kuo
D379,227 S 5/1997 Rosen
D380,046 S 6/1997 Domanowski
D398,641 S 9/1998 Hollington
D401,277 S 11/1998 Takemura
D404,763 S 1/1999 Shimizu
D404,764 S 1/1999 Perry et al.
D407,436 S 3/1999 Chevalier et al.
D408,854 S 4/1999 Katami

(**) Term: **14 Years**

(Continued)

(21) Appl. No.: **29/420,718**

OTHER PUBLICATIONS

(22) Filed: **May 11, 2012**

Non-Final Office Action mailed Aug. 31, 2011 related to U.S. Appl. No. 29/382,040.

(51) **LOC (9) Cl.** **19-06**

(52) **U.S. Cl.**
USPC **D19/55**

(Continued)

(58) **Field of Classification Search**
USPC D14/411; D19/35, 36, 41-51, 53-58;
24/11 F, 11 P, 11 R; 401/52, 99-109,
401/192, 195, 196

Primary Examiner — Elizabeth Albert
(74) *Attorney, Agent, or Firm* — Dicke, Billig & Czaja, PLLC

See application file for complete search history.

(57) **CLAIM**

(56) **References Cited**

We claim the ornamental design for a writing instrument, as shown and described.

U.S. PATENT DOCUMENTS

DESCRIPTION

D31,670 S	10/1899	Oberbeck	
2,007,245 A	7/1935	Gimonet	
D116,933 S	10/1939	Hirsch	
D127,598 S	6/1941	Gower	
D144,474 S	4/1946	Winslow	
D155,561 S	10/1949	Weiss	
D161,310 S	12/1950	Brown	
D243,014 S	1/1977	Wittnebert	
D264,854 S	6/1982	Spiegel	
D274,357 S	6/1984	Moreno	
D289,424 S *	4/1987	Huang	D19/36
D330,725 S *	11/1992	Samuel	D19/50
D333,677 S *	3/1993	Giralt	D19/48
D345,175 S *	3/1994	Giralt	D19/42
D349,129 S *	7/1994	Linderson et al.	D19/48
D364,186 S *	11/1995	Kuo	D19/48
D366,062 S	1/1996	Takahashi	

FIG. 1 is a perspective view of a writing instrument showing our new design;
FIG. 2 is a front view of FIG. 1;
FIG. 3 is a back view of FIG. 1;
FIG. 4 is a right side view of FIG. 1, the left side view being a mirror image of the right side view;
FIG. 5 is an enlarged top view of FIG. 1; and,
FIG. 6 is a bottom perspective view of FIG. 1.
The broken lines in the drawings of FIGS. 1-6 are included for the purpose of showing portions that form no part of the claimed design.

1 Claim, 5 Drawing Sheets



(56)

References Cited

U.S. PATENT DOCUMENTS

D416,577 S	11/1999	Andrews et al.	
D422,024 S	3/2000	Andrews et al.	
6,164,856 A *	12/2000	Lo	401/52
D453,187 S	1/2002	Keda	
D454,158 S	3/2002	Takanashi	
D482,724 S	11/2003	Nishida	
D492,724 S	7/2004	Kimura	
D502,503 S	3/2005	Kimura	
D526,020 S	8/2006	Cetera	
D533,593 S	12/2006	Kimura	
D542,350 S	5/2007	Shibata	
D547,374 S *	7/2007	Deng	D19/36
D553,189 S	10/2007	Qiu	
D562,384 S *	2/2008	Qiu	D19/36
D566,176 S	4/2008	Rolion et al.	
D569,434 S *	5/2008	Cetera	D19/55
D576,211 S	9/2008	Qiu et al.	
D576,212 S	9/2008	Qiu et al.	
D625,412 S	10/2010	Garito et al.	
D647,963 S *	11/2011	Chu	D19/47
D670,761 S *	11/2012	Fleming	D19/47

OTHER PUBLICATIONS

Photographs of “Imperial-Silver” model of pen manufactured by Sheaffer and conceded to publicly known as early as the late-1960s, as shown at <http://www.sheaffertarga.com/Imperial%20and%20Triumph/Sterling%20silver%20diamond%20pattern2.html>, downloaded Dec. 28, 2010.

Photographs of “Triumph—Coarse Barleycorn Gold Plate” model of pen manufactured by Sheaffer and conceded to publicly known as early as the late-1960s, as shown at <http://www.sheaffertarga.com/Imperial%20and%20Triumph/Triumph%20GP%20Coarse%20Barley.html>, downloaded Dec. 28, 2010.

Photographs of No. 835 “Imperial Gold Plated Diamond Pattern” model of pen manufactured by Sheaffer and conceded to publicly known as early as the late-1960s, as shown at <http://www.sheaffertarga.com/Imperial%20and%20Triumph/835%20gold%20plated%20diamond%20pattern.html>, downloaded Dec. 28, 2010.

* cited by examiner

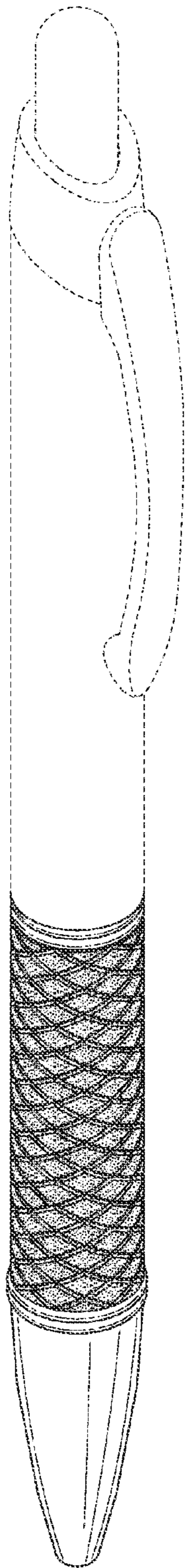

Fig. 1

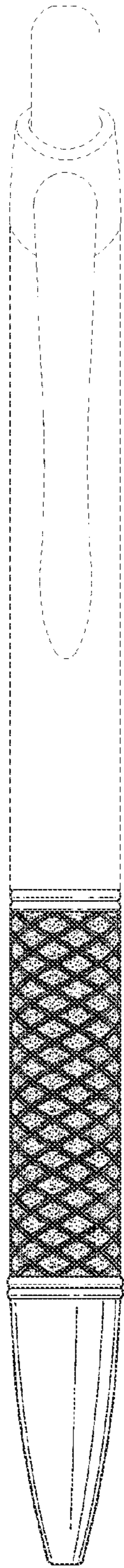

Fig. 2

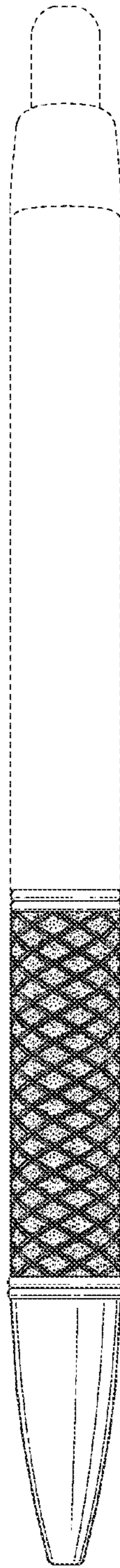

Fig. 3

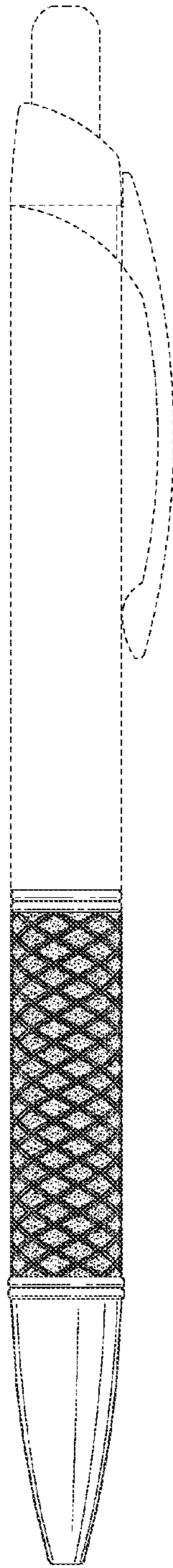

Fig. 4

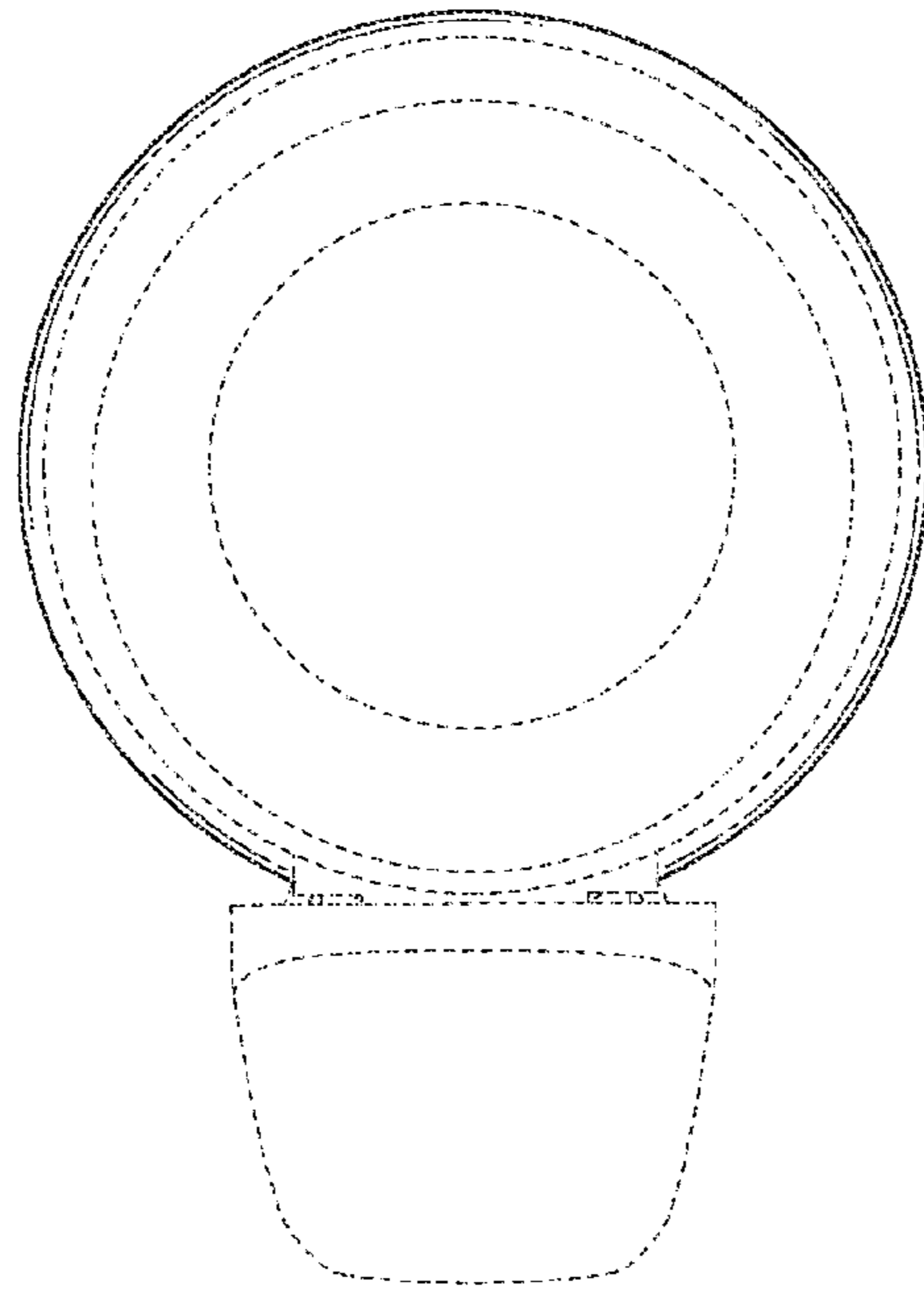

Fig. 5

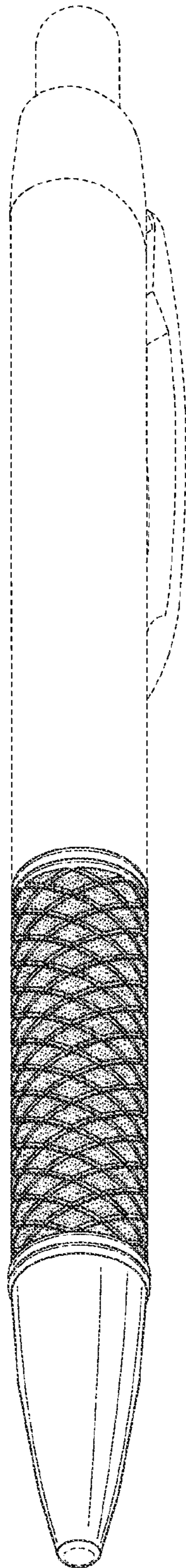

Fig. 6