



US00D692464S

(12) **United States Design Patent**  
**Sumitani et al.**

(10) **Patent No.:** **US D692,464 S**

(45) **Date of Patent:** **\*\* Oct. 29, 2013**

(54) **CATERPILLAR CAR FOR POWER SHOVEL**

D663,324 S *	7/2012	Fuchita et al.	.....	D15/25
D663,751 S *	7/2012	Yogita et al.	.....	D15/25
D677,703 S *	3/2013	Hiraoka et al.	.....	D15/25
D678,354 S *	3/2013	Hiraoka et al.	.....	D15/25
D682,322 S *	5/2013	Suzuki	.....	D15/25

(71) Applicant: **Caterpillar SARL**, Geneva (CH)

(72) Inventors: **Naoya Sumitani**, Tokyo (JP); **Junji Mizugaki**, Tokyo (JP); **Takahiro Sadamoto**, Tokyo (JP); **Kazushige Okamoto**, Tokyo (JP); **Kenji Yokohata**, Tokyo (JP); **Yuuichi Hayata**, Kobe (JP); **Shigemi Togo**, Kobe (JP)

FOREIGN PATENT DOCUMENTS

JP D1374569 S 11/2012

\* cited by examiner

(73) Assignee: **Caterpillar SARL**, Geneva (CH)

*Primary Examiner* — Mark Goodwin

(\*\*) Term: **14 Years**

(74) *Attorney, Agent, or Firm* — Law Office of Katsuhiko Arai

(21) Appl. No.: **29/453,594**

(57) **CLAIM**

(22) Filed: **Apr. 30, 2013**

The ornamental design for a caterpillar car for a power shovel, as shown and described.

(30) **Foreign Application Priority Data**

**DESCRIPTION**

Dec. 27, 2012 (JP) ..... 2012-031853

(51) **LOC (9) Cl.** ..... **12-09**

(52) **U.S. Cl.**  
USPC ..... **D15/24**

(58) **Field of Classification Search**  
USPC ..... D15/10, 22-26; 37/403, 411, 443;  
414/685, 686, 688, 722-724;  
180/89.13

See application file for complete search history.

FIG. 1 is a front elevational view of the caterpillar car for power shovel showing our new design; FIG. 2 is a rear elevation thereof; FIG. 3 is a left side elevation thereof; FIG. 4 is a right side elevation thereof; FIG. 5 is a plan view thereof; FIG. 6 is a front left perspective view thereof; FIG. 7 is a front right perspective view thereof; FIG. 8 is a rear right perspective view thereof; and, FIG. 9 is a rear left perspective view thereof.

(56) **References Cited**

U.S. PATENT DOCUMENTS

D437,602 S *	2/2001	Hiraoka et al.	.....	D15/25
D462,973 S *	9/2002	Tamaru et al.	.....	D15/25
D462,974 S *	9/2002	Yanagida et al.	.....	D15/25
D463,455 S *	9/2002	Yanagida et al.	.....	D15/25
D609,252 S *	2/2010	Shimada et al.	.....	D15/25
D658,211 S *	4/2012	Hiraoka et al.	.....	D15/25

The portions at the front right of the design with oblique line shading in FIGS. 1, 3, 4, and 6-9 are illustrated as being transparent and an internal structure is omitted. A bottom elevation is omitted since the caterpillar car is a heavy vehicle and is generally not seen from the bottom, and also the design can accurately be understood without a bottom elevation.

**1 Claim, 9 Drawing Sheets**

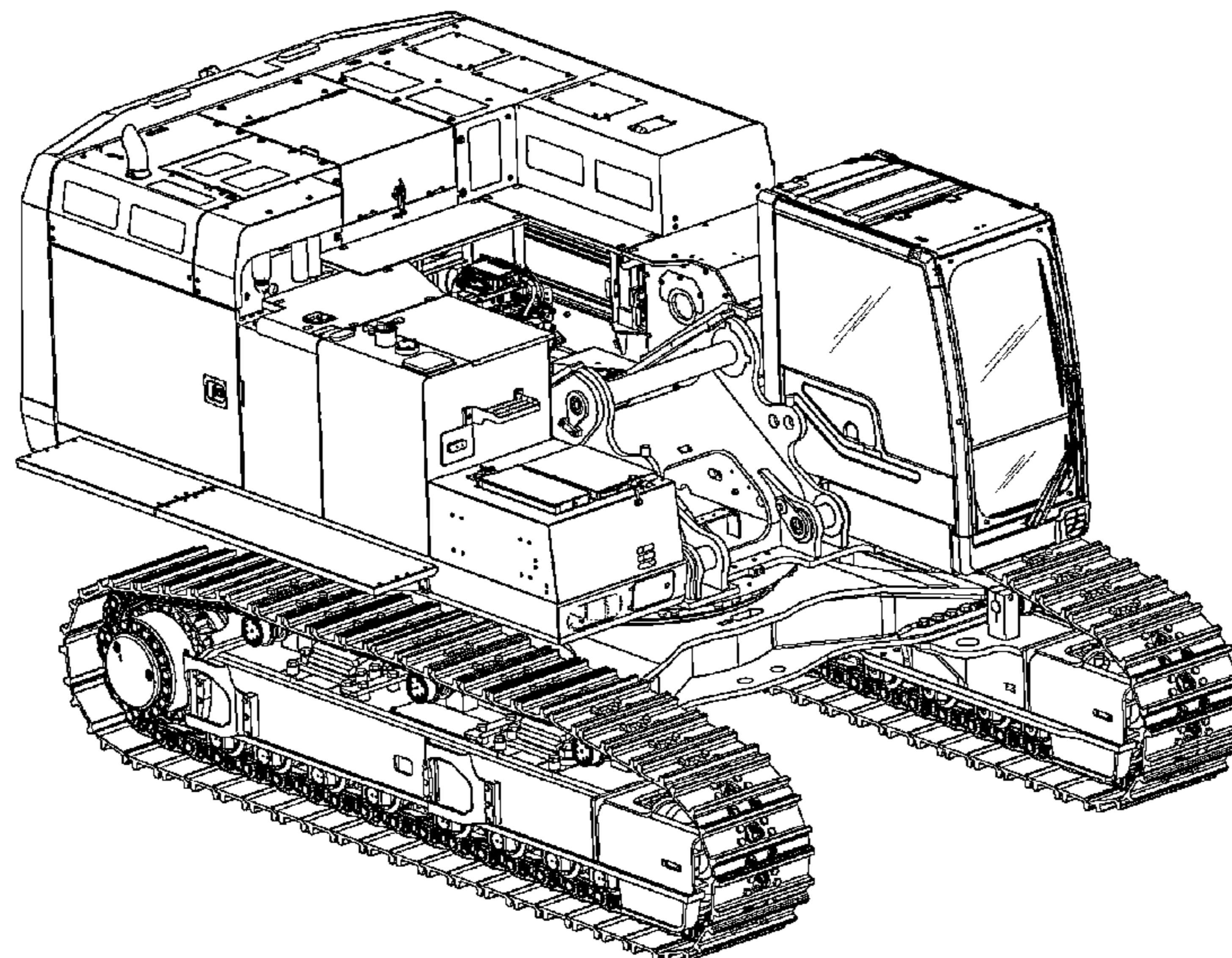

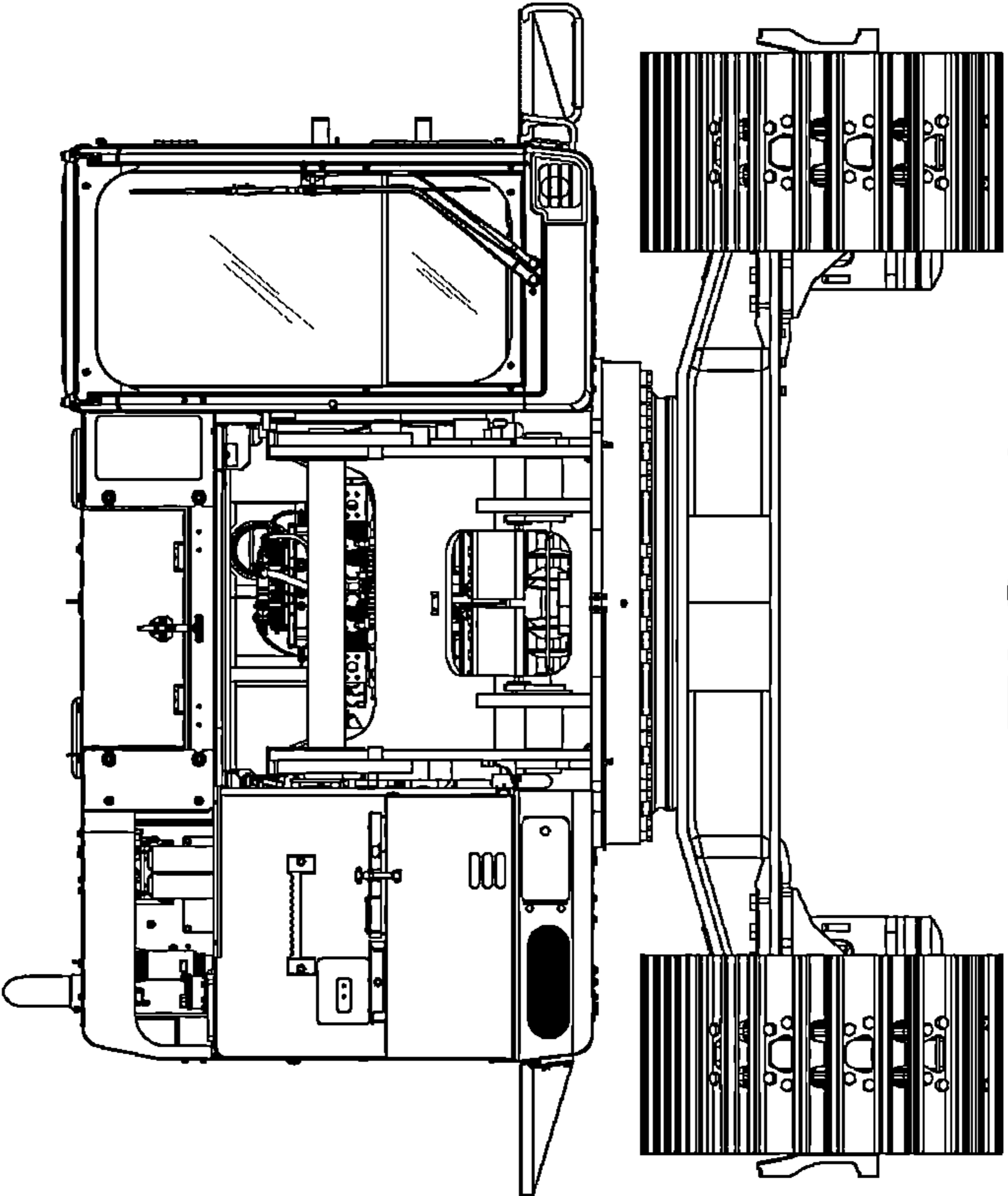

FIG. 1

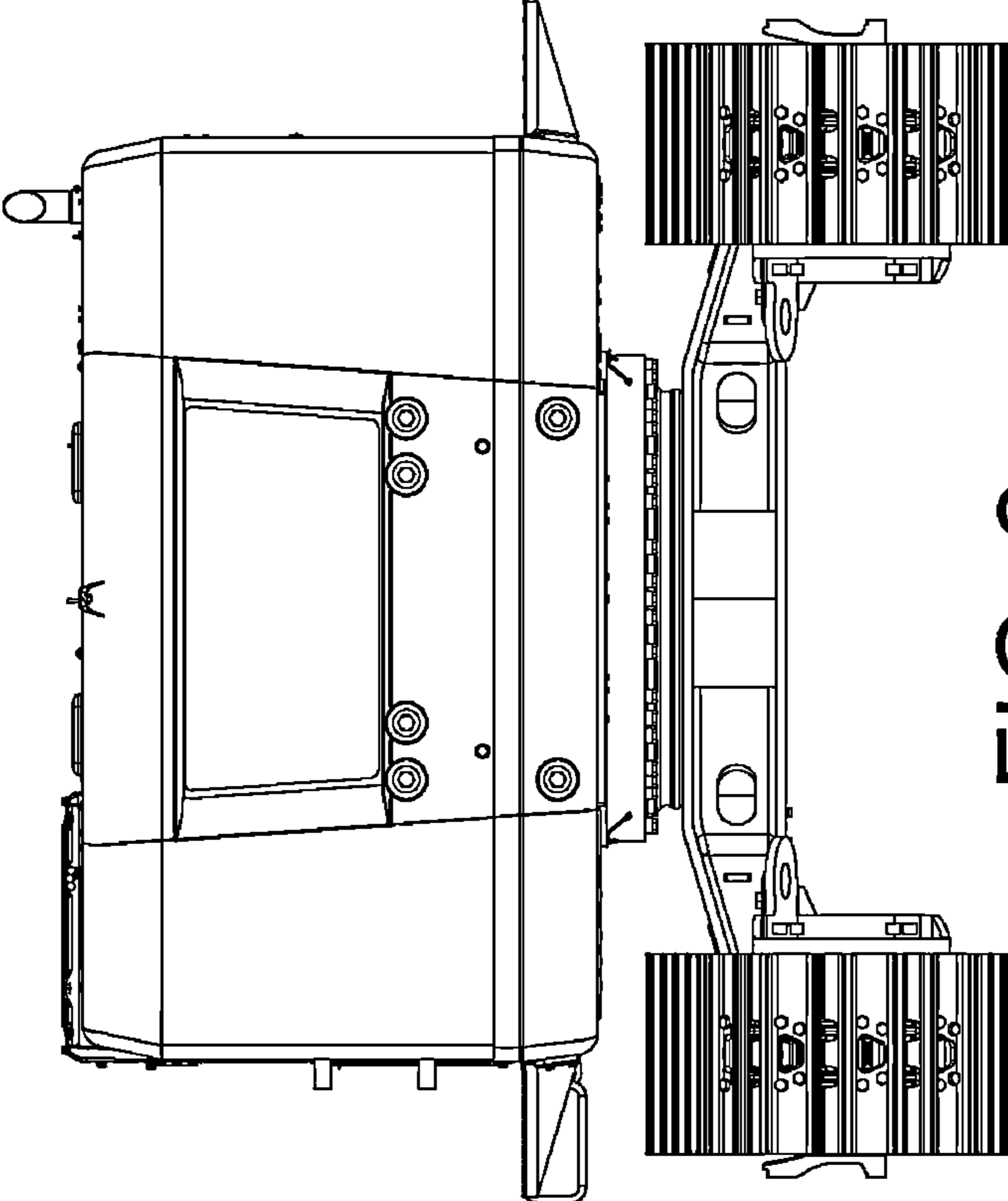

FIG. 2

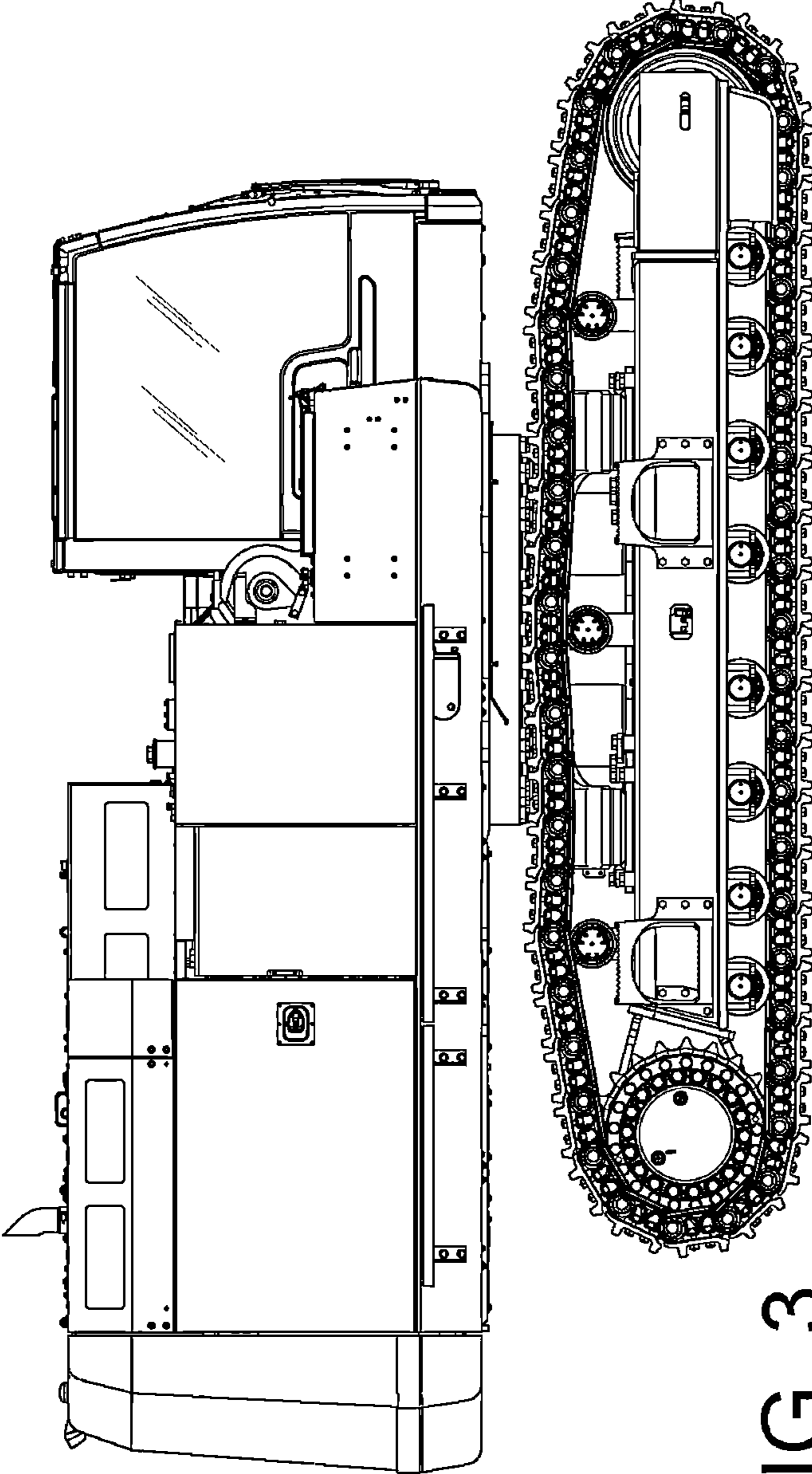

FIG. 3



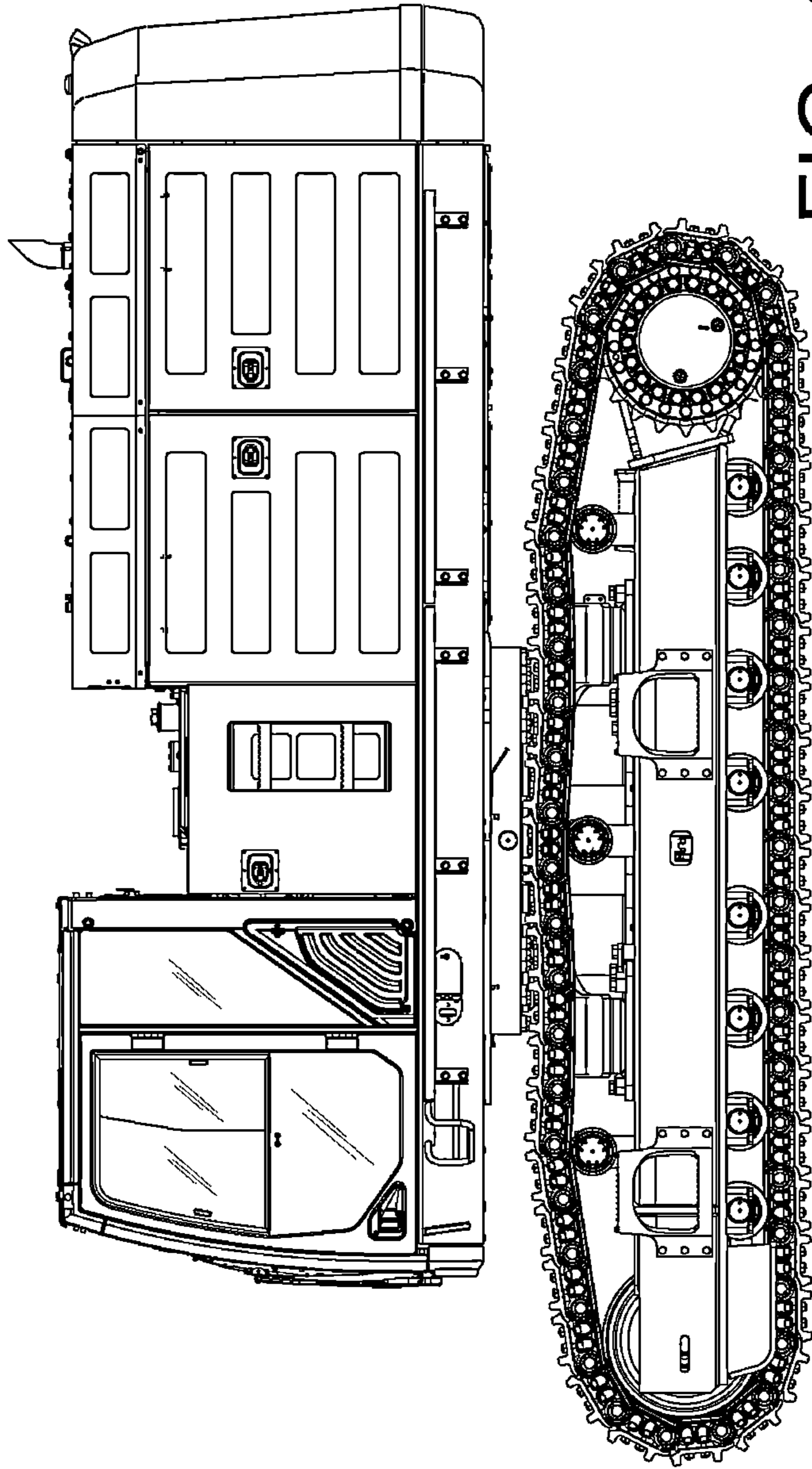

FIG. 4

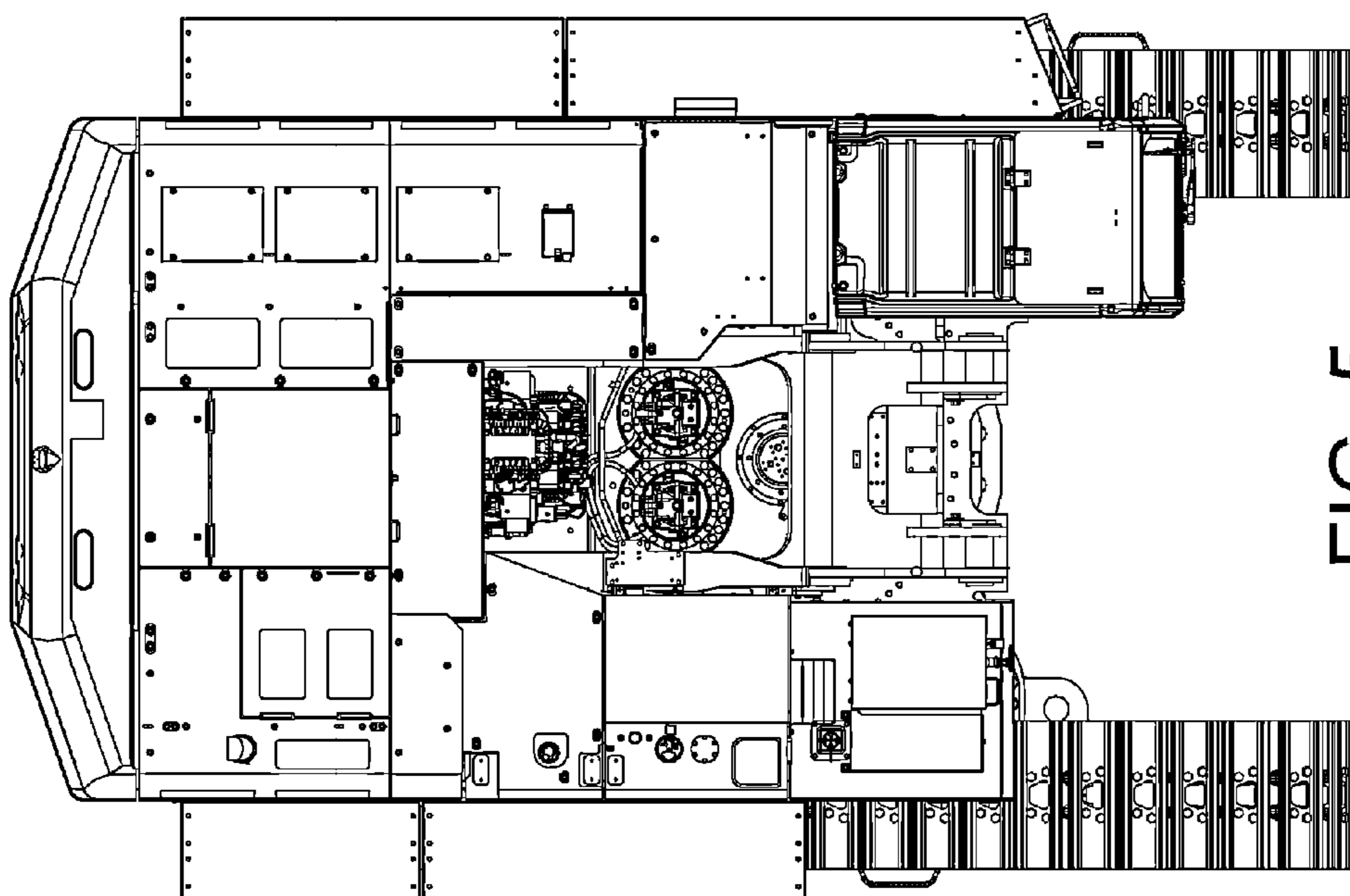

FIG. 5

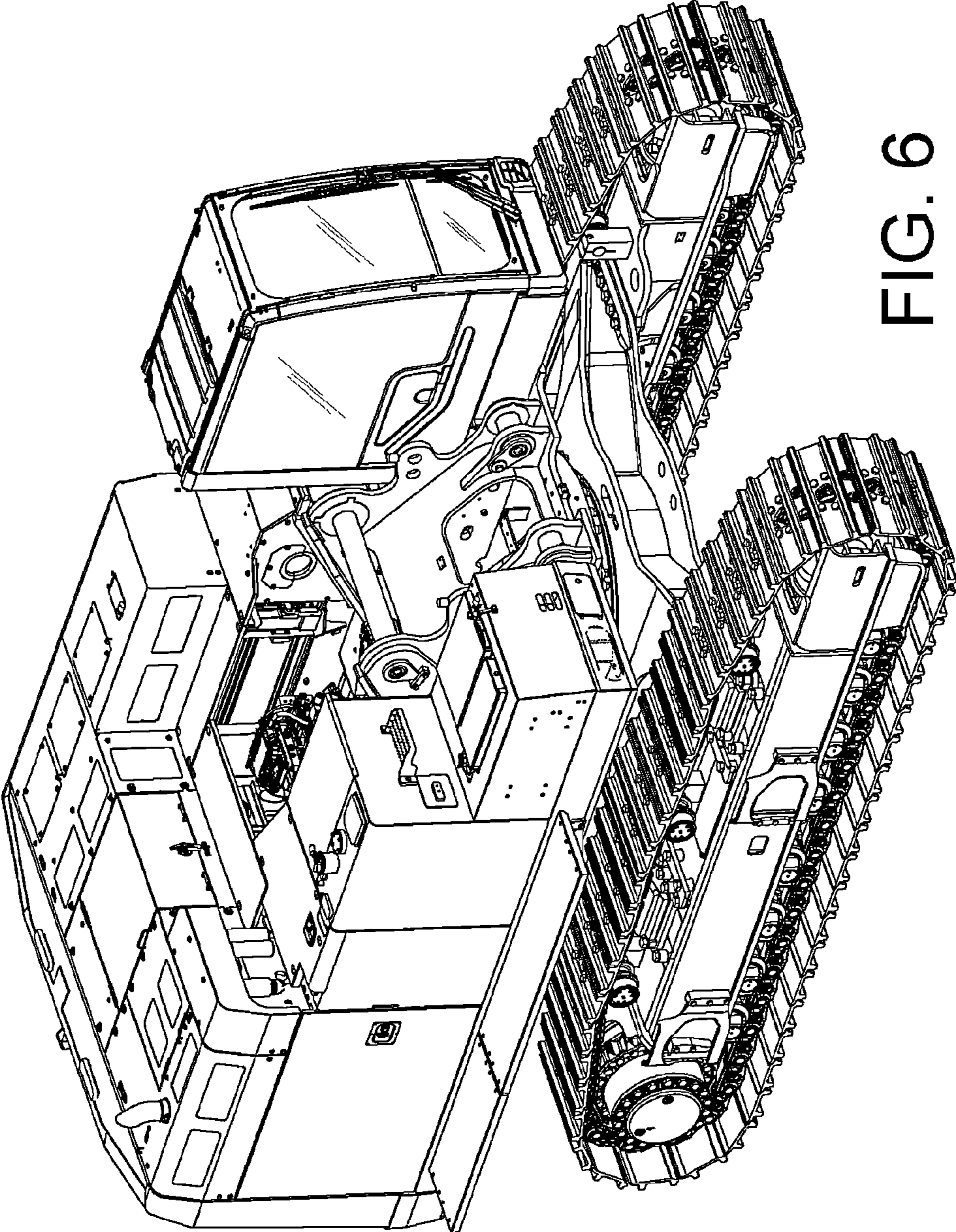

FIG. 6



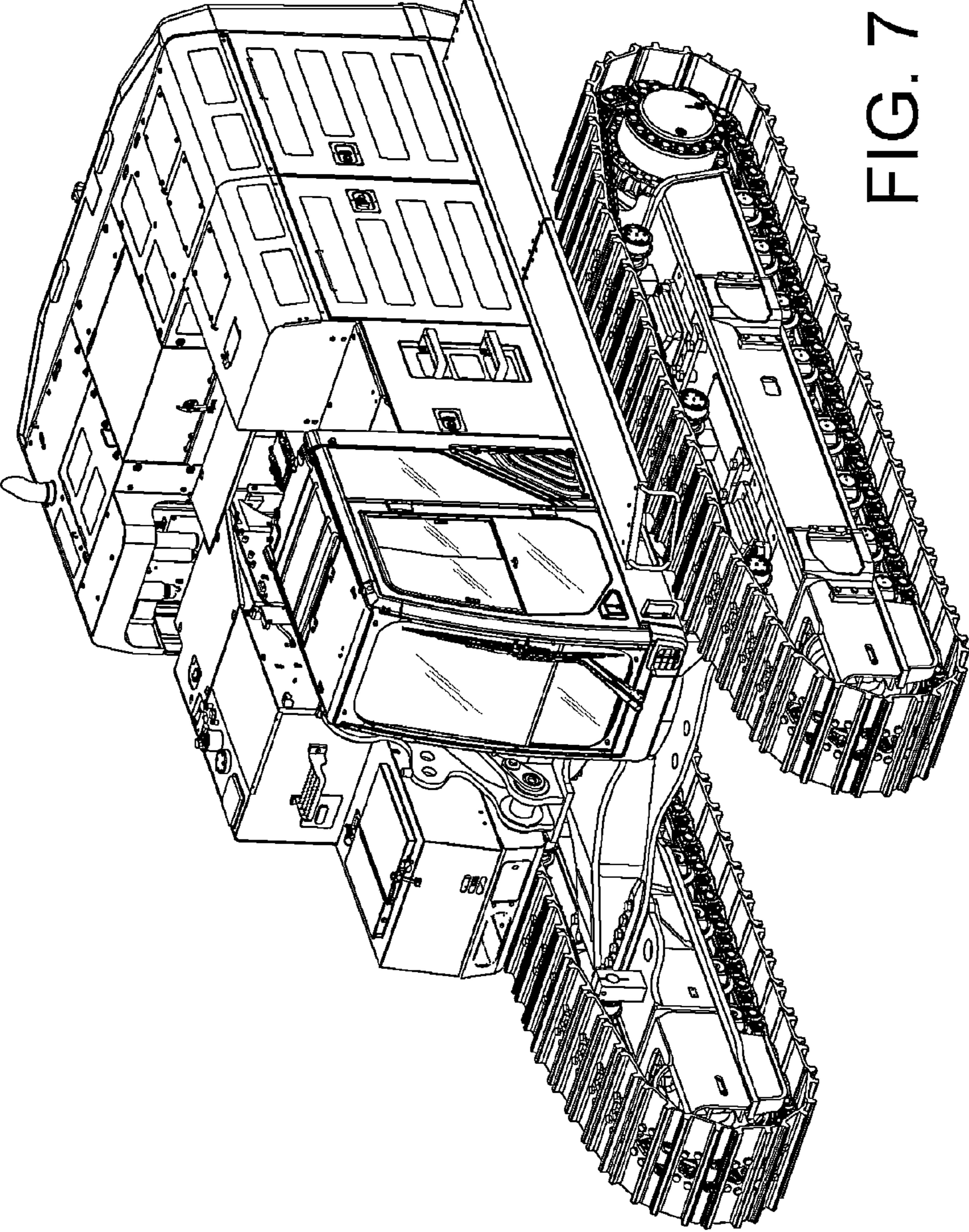

FIG. 7



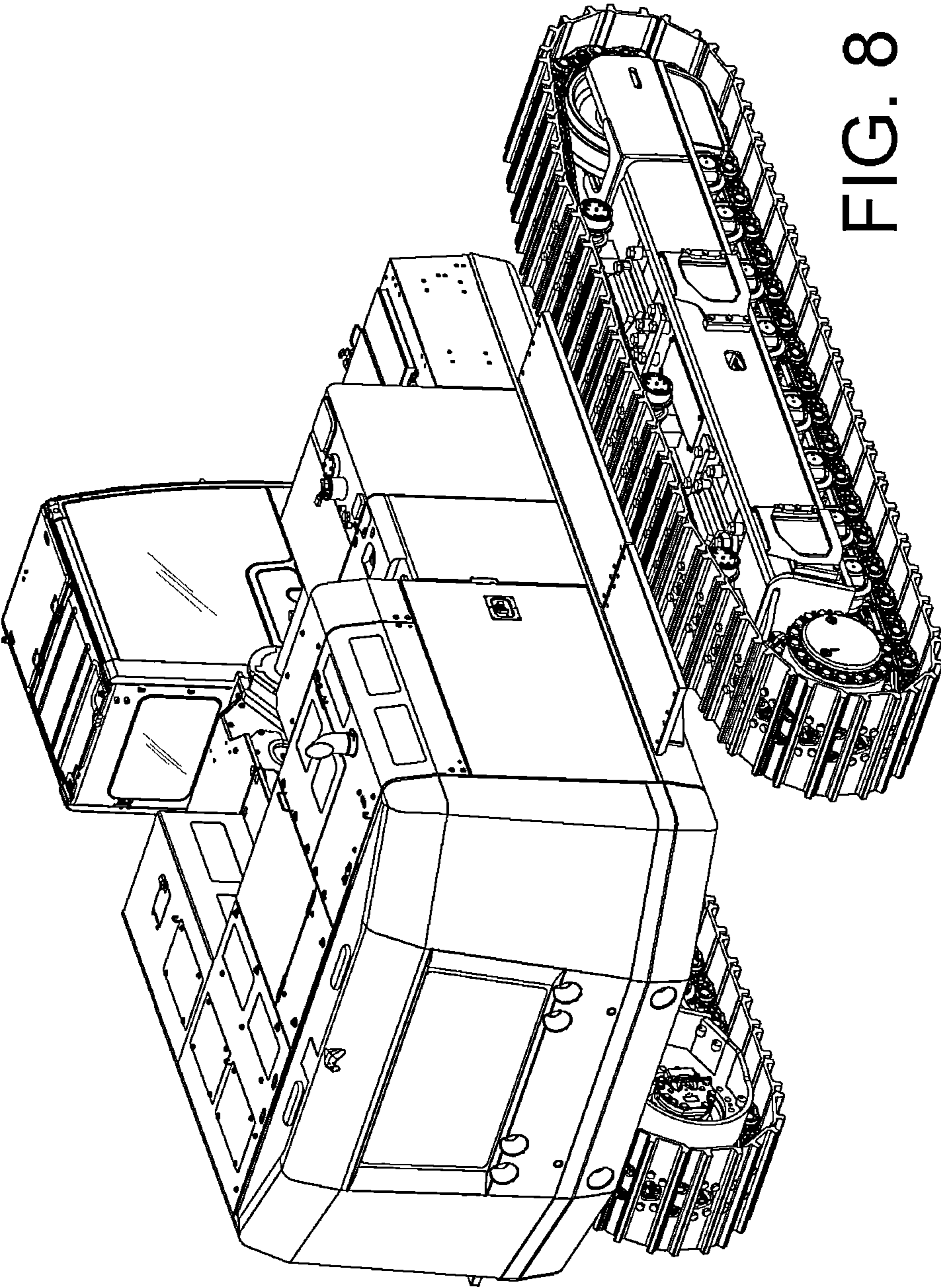

FIG. 8

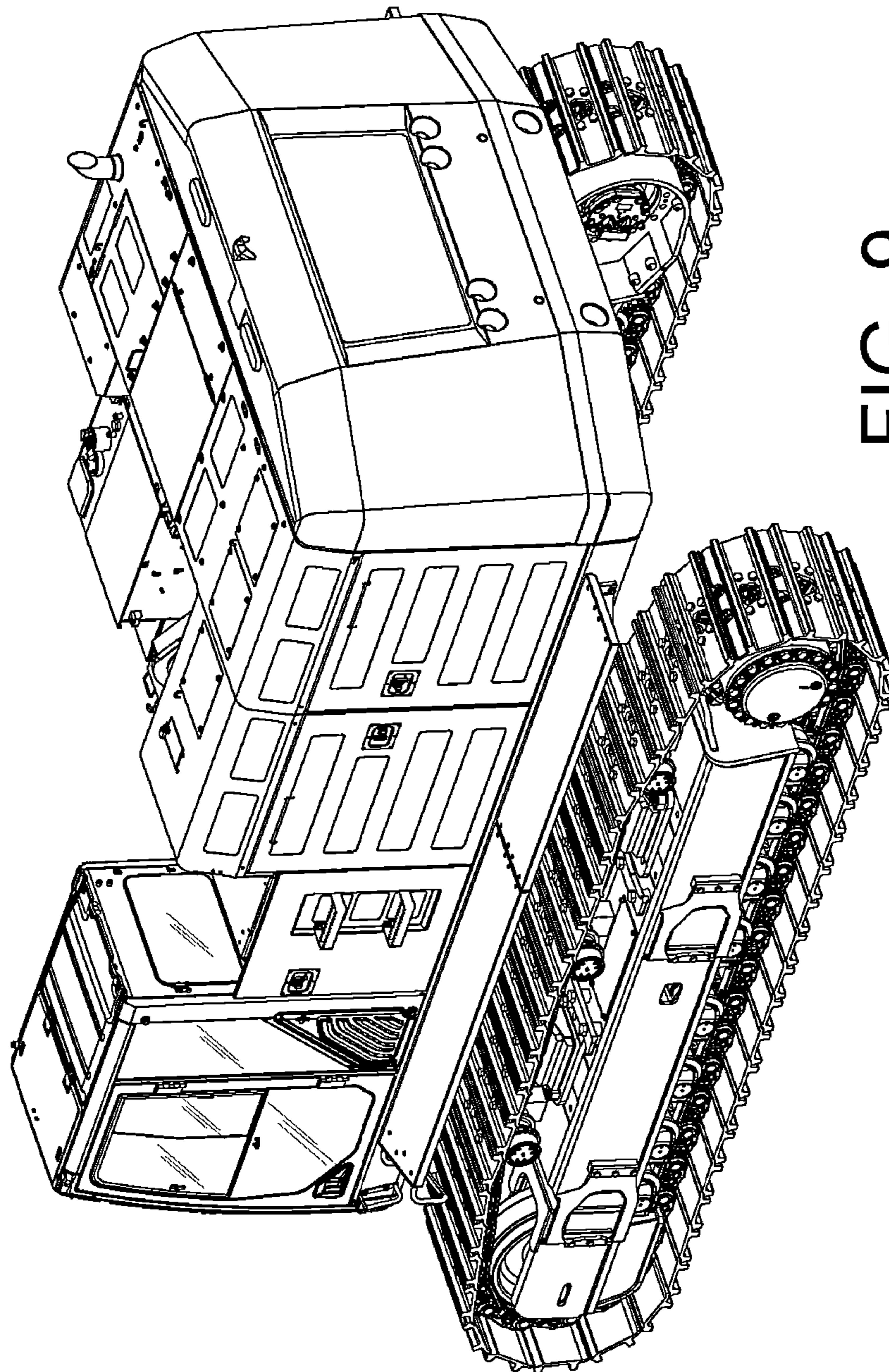

FIG. 9