



US00D692399S

(12) **United States Design Patent**
Felegy, Jr. et al.

(10) **Patent No.:** **US D692,399 S**
(45) **Date of Patent:** **** Oct. 29, 2013**

(54) **TABLETOP REMOTE LOAD CONTROL DEVICE**

(75) Inventors: **Edward M. Felegy, Jr.**, Macungie, PA (US); **David William Petrillo**, Pennington, NJ (US); **Gregory M. Snyder**, Germansville, PA (US); **Gregory Altonen**, Easton, PA (US); **Elliot G. Jacoby**, Glenside, PA (US); **Joel S. Spira**, Coopersburg, PA (US)

(73) Assignee: **Lutron Electronics, Co., Inc.**, Coopersburg, PA (US)

(**) Term: **14 Years**

(21) Appl. No.: **29/423,146**

(22) Filed: **May 29, 2012**

(51) **LOC (9) Cl.** **14-03**

(52) **U.S. Cl.**
USPC **D13/168**

(58) **Field of Classification Search**
USPC D13/168; D10/104.1, 106.1; D14/218; 315/158, 209 R, 224, 246, 291, 294, 315/295; 340/4.3, 4.42, 12.22, 12.23, 340/12.24, 12.29, 12.3, 13.2, 13.21, 13.24; 341/176; 345/169; 348/734; 455/352; 463/39; 700/17, 65, 83
See application file for complete search history.

(56) **References Cited**

U.S. PATENT DOCUMENTS

5,248,919	A *	9/1993	Hanna et al.	315/291
D353,798	S *	12/1994	Bryde et al.	D13/169
6,037,721	A *	3/2000	Lansing et al.	315/295
6,169,377	B1 *	1/2001	Bryde et al.	315/294
D439,220	S *	3/2001	Mayo et al.	D13/125
D450,043	S	11/2001	Mosebrook	
D496,335	S *	9/2004	Spira	D13/168
7,190,125	B2 *	3/2007	McDonough et al.	315/291
D543,158	S *	5/2007	Blair et al.	D13/162
7,382,100	B2 *	6/2008	Johnson et al.	315/297
D583,337	S *	12/2008	Ni	D13/171
D592,606	S	5/2009	Felegy, Jr. et al.	

D592,607	S *	5/2009	Felegy et al.	D13/168
7,579,717	B2	8/2009	Blair et al.	
D606,500	S *	12/2009	Snyder et al.	D13/174
D614,146	S *	4/2010	Felegy et al.	D13/168
D616,835	S *	6/2010	Felegy et al.	D13/168
D619,105	S	7/2010	Felegy, Jr. et al.	
D619,544	S	7/2010	Petrillo et al.	
D627,307	S *	11/2010	Petrillo et al.	D13/168
D627,308	S *	11/2010	Snyder et al.	D13/168
D627,309	S *	11/2010	Snyder et al.	D13/171
D636,739	S *	4/2011	Petrillo et al.	D13/168
D646,232	S *	10/2011	Felegy et al.	D13/168
D655,254	S *	3/2012	Jacoby et al.	D13/168
D661,664	S	6/2012	Felegy, Jr. et al.	

OTHER PUBLICATIONS

Lutron Electronics., Inc., AuroRA Wireless Lighting Control Brochure, Nov. 2006, 2 pages.*
Crestron Electronics, Inc., Crestron Green Light Product Line Overview, Mar. 2010, 16 pages.
Crestron Electronics, Inc., Cameo Express Wireless In-Wall Dimmer Specification Sheet, Jun. 8, 2010, 3 pages.
Crestron Electronics, Inc., Crestron CLW-DIMSWEX-P. Dimmer/Switch Combo Installation Guide, May 2, 2011, 4 sheets.
U.S. Appl. No. 29/423,142, filed May 29, 2012, Felegy, Jr. et al.
U.S. Appl. No. 29/423,149, filed May 29, 2012, Felegy, Jr. et al.
U.S. Appl. No. 29/423,152, filed May 29, 2012, Felegy, Jr. et al.

* cited by examiner

Primary Examiner — Selina Sikder

(74) *Attorney, Agent, or Firm* — Mark E. Rose; Philip N. Smith; Bridget L. McDonough

(57) **CLAIM**

We claim the ornamental design for a tabletop remote load control device, as shown and described.

DESCRIPTION

FIG. 1 is a perspective view of a tabletop remote load control device according to a first embodiment of our new design.
FIG. 2 is a front view thereof.
FIG. 3 is a left side view thereof.
FIG. 4 is a right side view thereof.
FIG. 5 is a top view thereof.
FIG. 6 is a bottom view thereof.

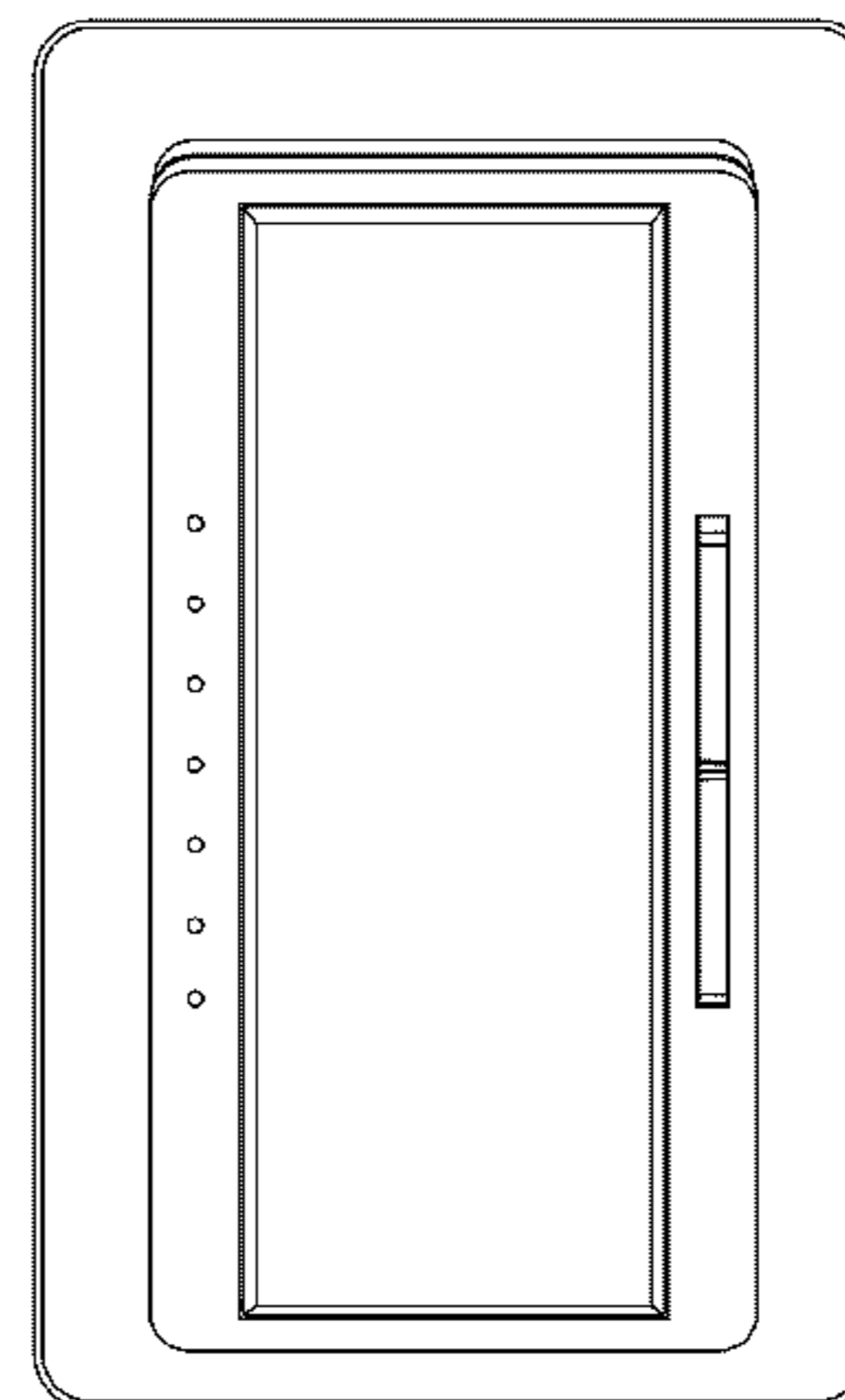
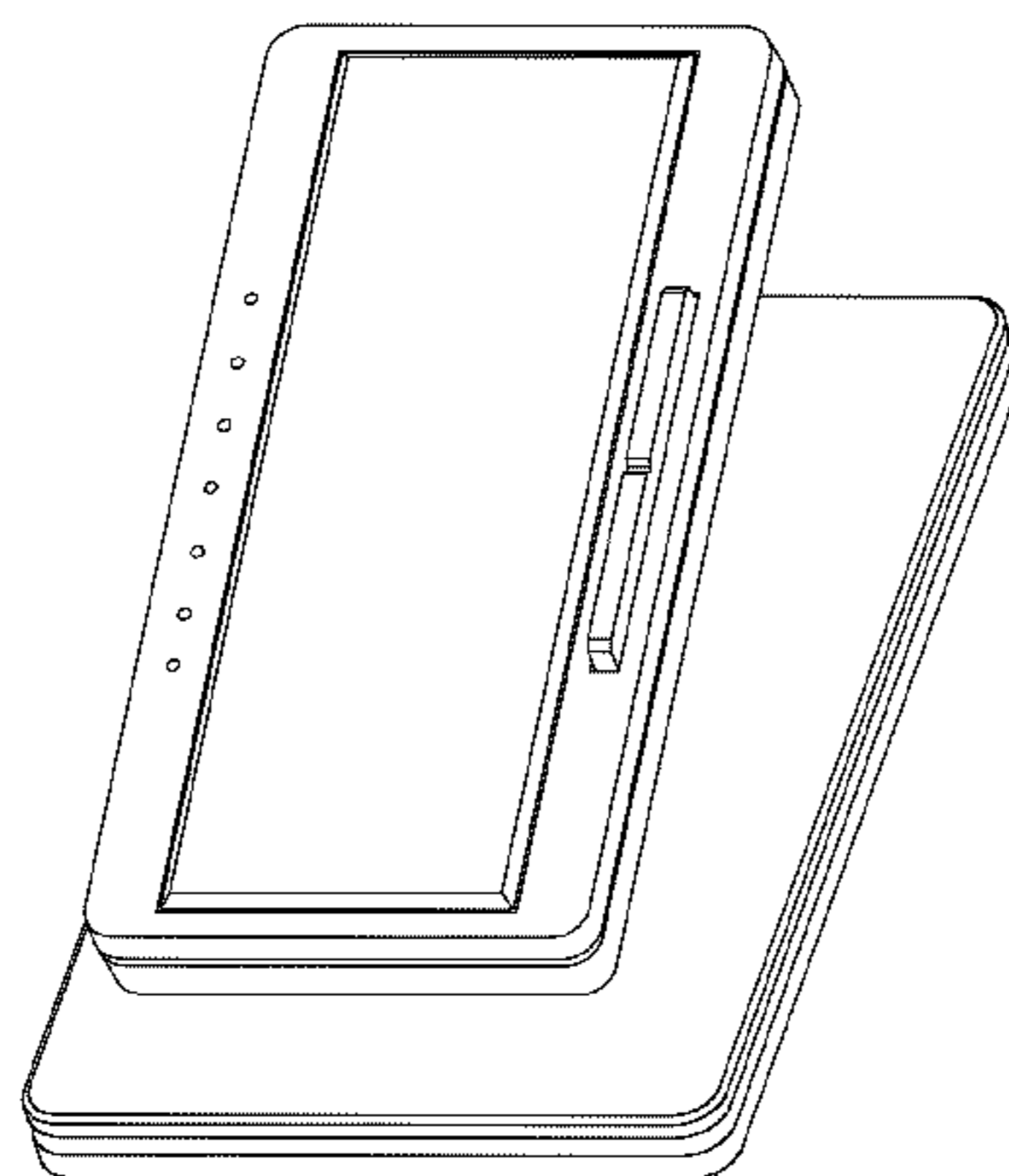

FIG. 7 is a perspective view of a tabletop remote load control device according to a second embodiment of our new design.

FIG. 8 is a front view thereof.

FIG. 9 is a bottom view thereof, the left side, right side, and top views, respectively, of the second embodiment being identical to the left side, right side, and top views of the first embodiment.

FIG. 10 is a perspective view of a tabletop remote load control device according to a third embodiment of our new design.

FIG. 11 is a front view thereof.

FIG. 12 is a left side view thereof.

FIG. 13 is a right side view thereof.

FIG. 14 is a top view thereof.

FIG. 15 is a bottom view thereof.

FIG. 16 is a perspective view of a tabletop remote load control device according to a fourth embodiment of our new design.

FIG. 17 is a front view thereof.

FIG. 18 is a bottom view thereof, the left side, right side, and top views, respectively, of the fourth embodiment being identical to the left side, right side, and top views of the third embodiment.

FIG. 19 is a perspective view of a tabletop remote load control device according to a fifth embodiment of our new design.

FIG. 20 is a front view thereof.

FIG. 21 is a left side view thereof.

FIG. 22 is a right side view thereof.

FIG. 23 is a top view thereof.

FIG. 24 is a bottom view thereof.

FIG. 25 is a perspective view of a tabletop remote load control device according to a sixth embodiment of our new design.

FIG. 26 is a front view thereof.

FIG. 27 is a bottom view thereof, the left side, right side, and top views, respectively, of the sixth embodiment being identical to the left side, right side, and top views of the fifth embodiment.

FIG. 28 is a perspective view of a tabletop remote load control device according to a seventh embodiment of our new design.

FIG. 29 is a front view thereof.

FIG. 30 is a left side view thereof.

FIG. 31 is a right side view thereof.

FIG. 32 is a top view thereof.

FIG. 33 is a bottom view thereof.

FIG. 34 is a perspective view of a tabletop remote load control device according to an eighth embodiment of our new design.

FIG. 35 is a front view thereof; and,

FIG. 36 is a bottom view thereof, the left side, right side, and top views, respectively, of the eighth embodiment being identical to the left side, right side, and top views of the seventh embodiment.

The rear views form no part of the design and are omitted.

1 Claim, 28 Drawing Sheets

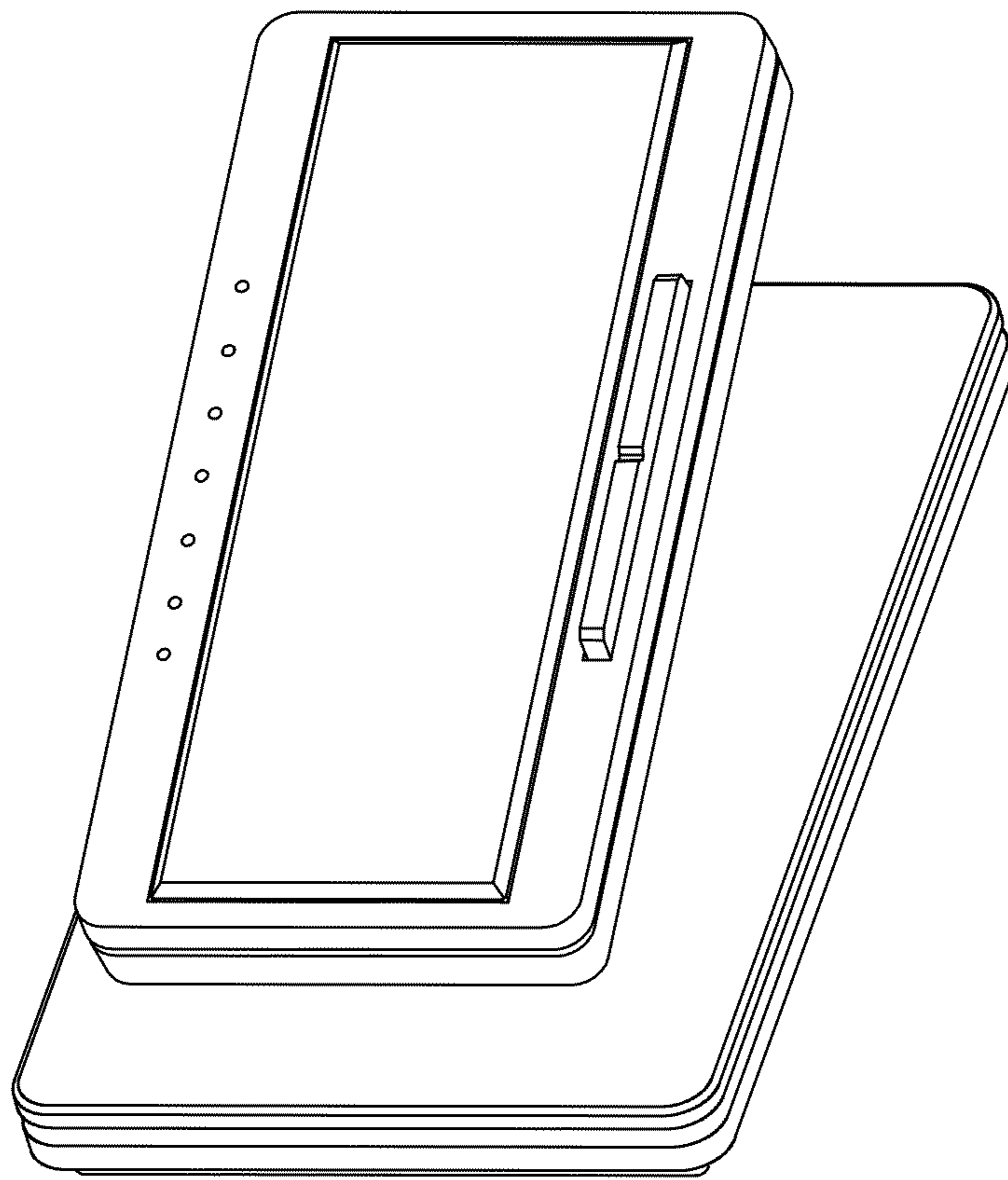

Fig. 1

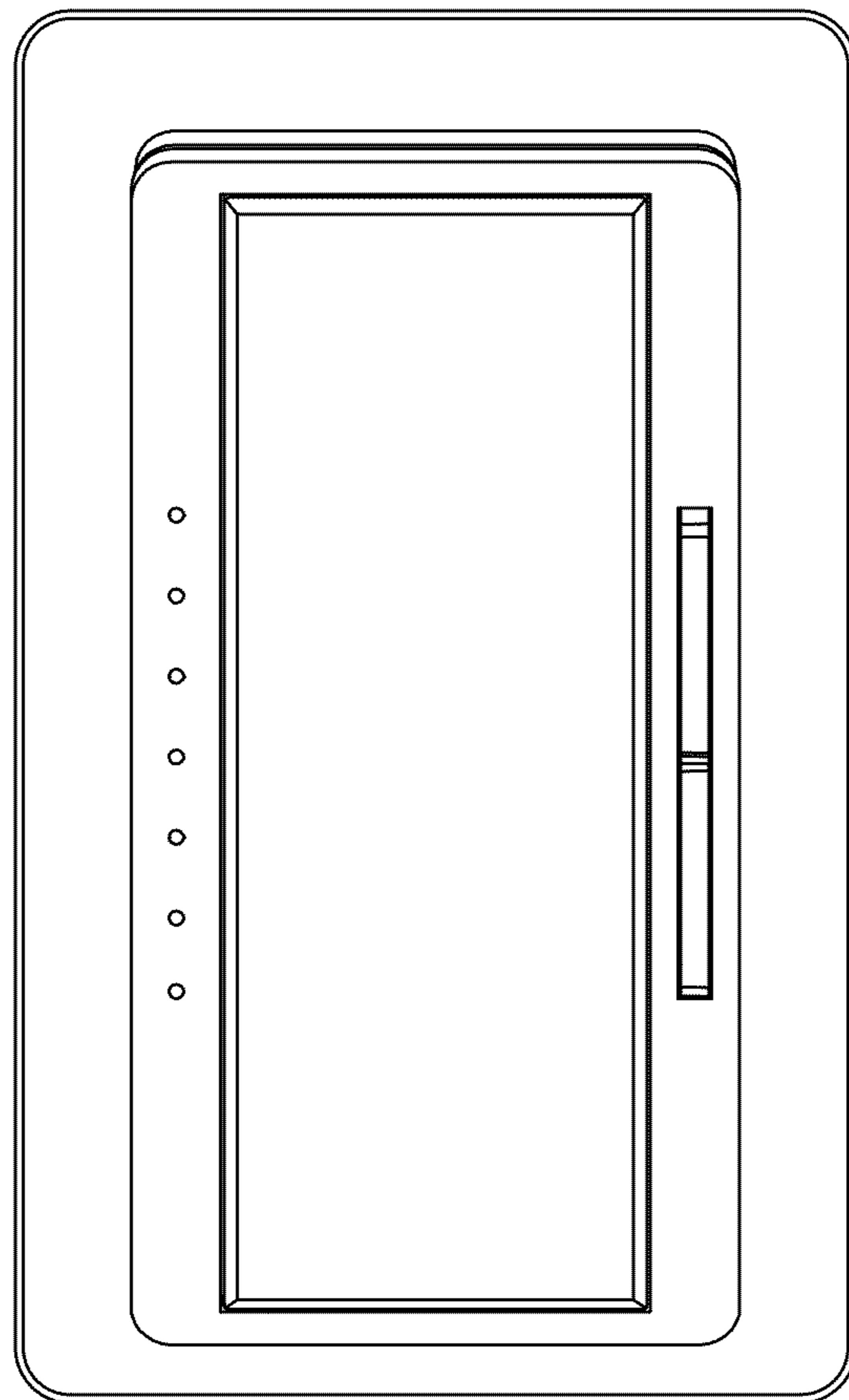

Fig. 2

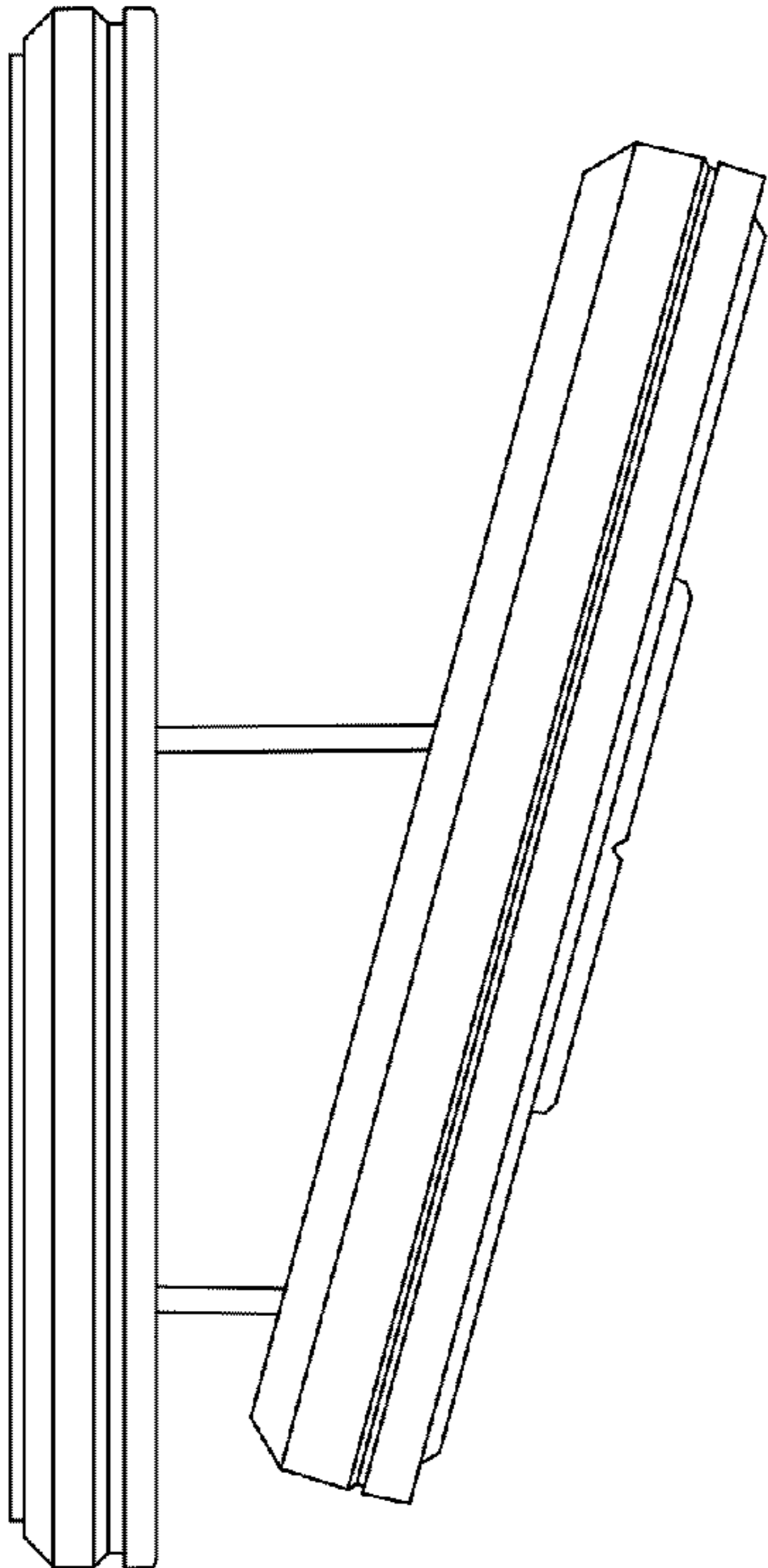

Fig. 3

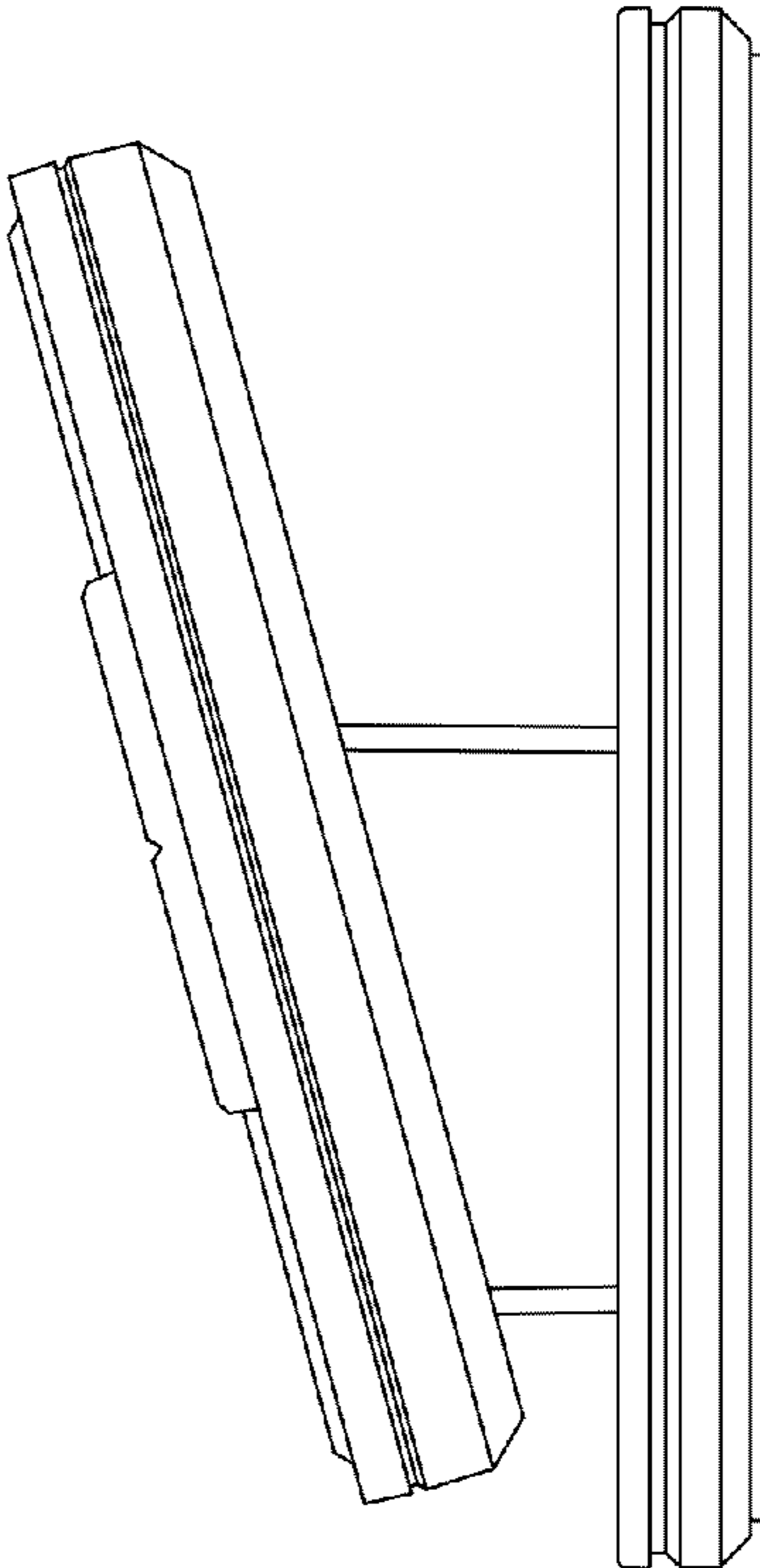

Fig. 4

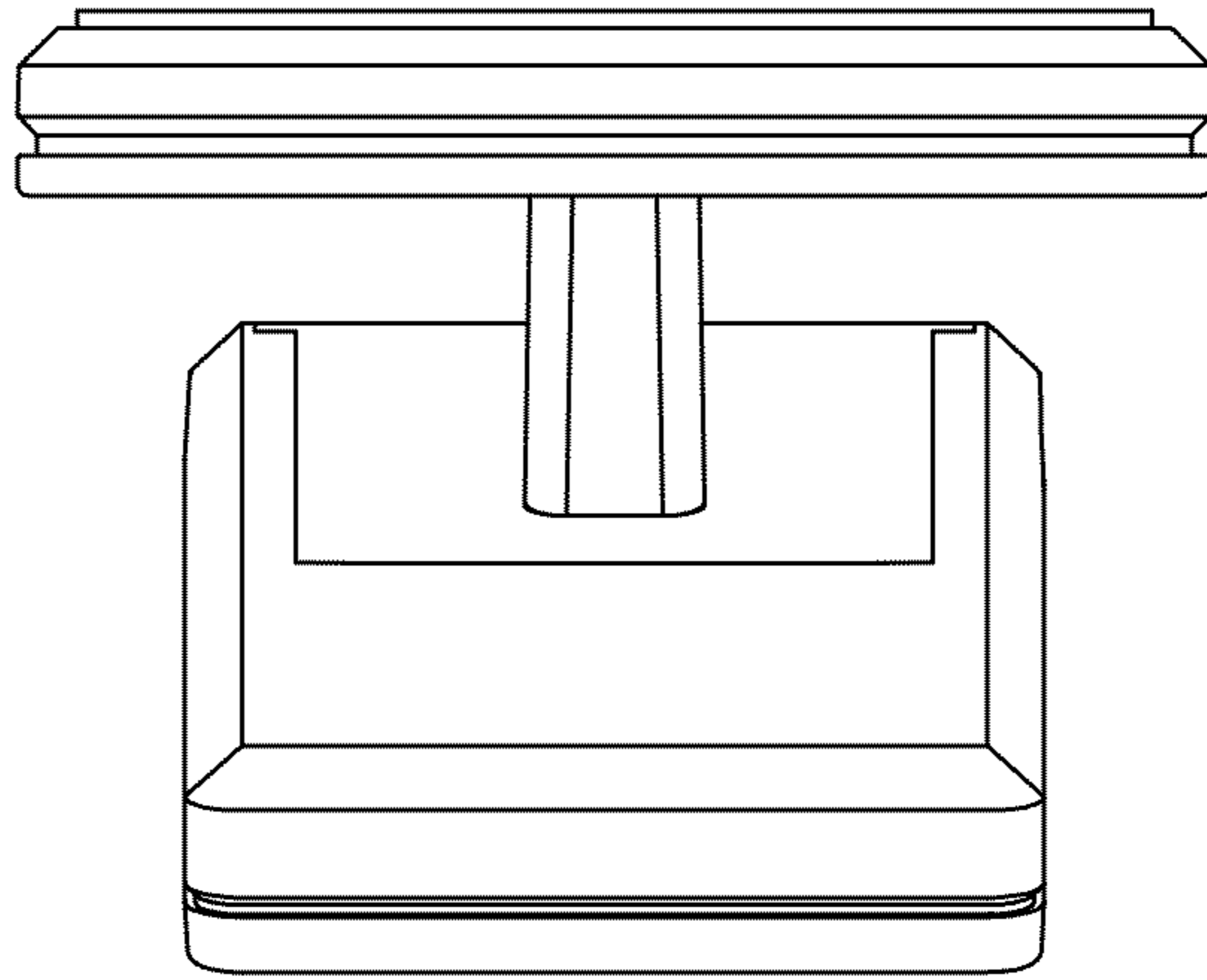

Fig. 5

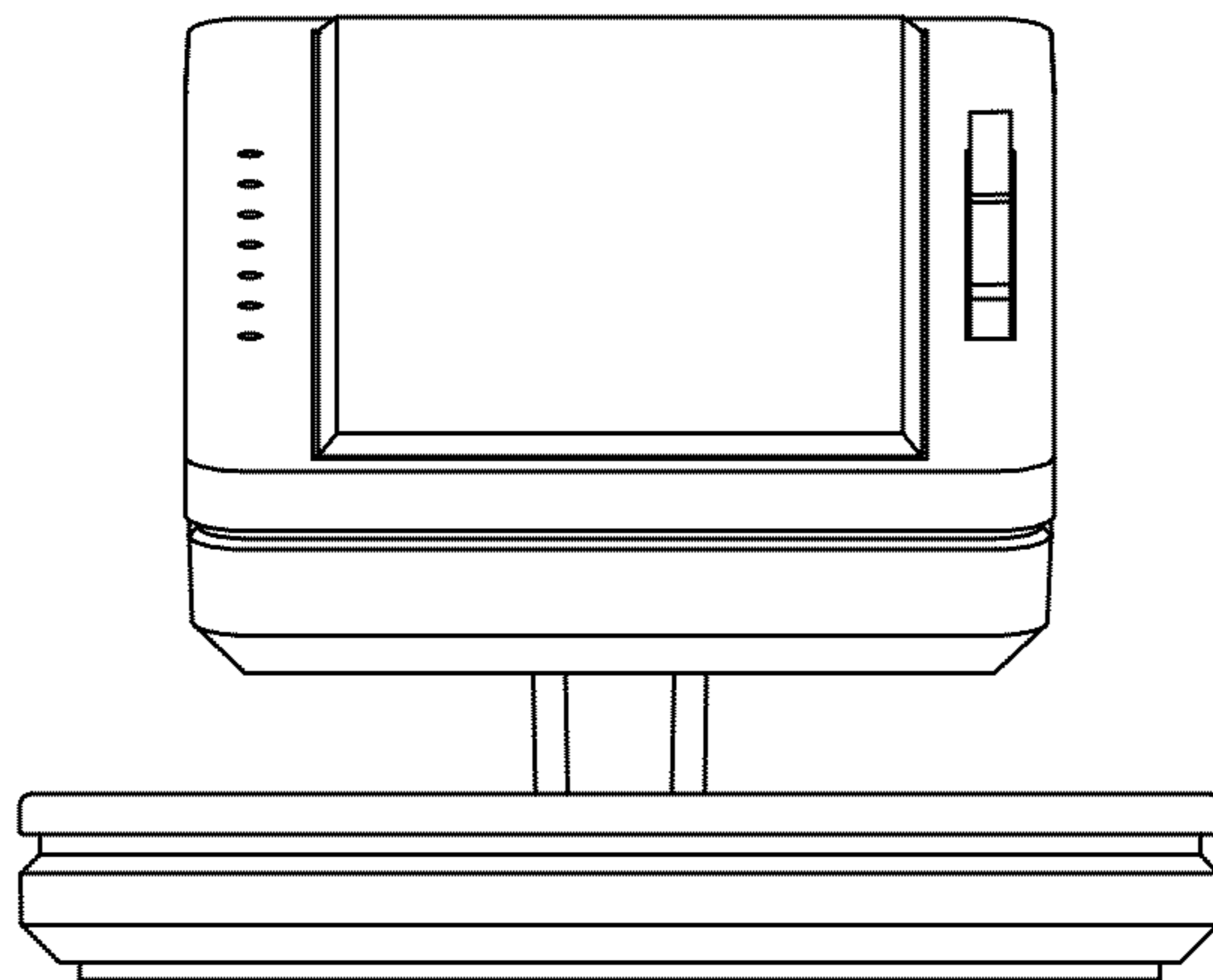

Fig. 6

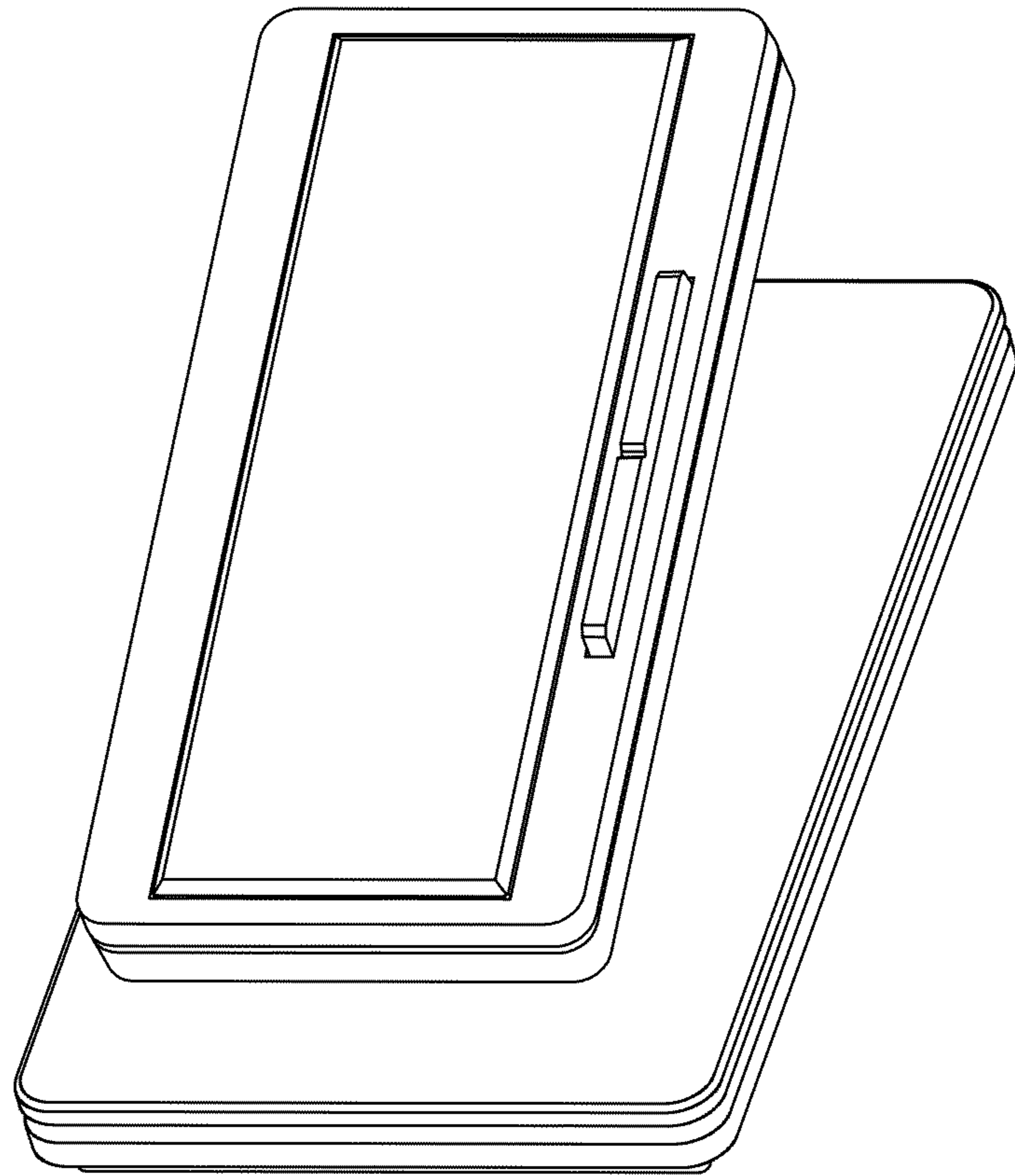

Fig. 7

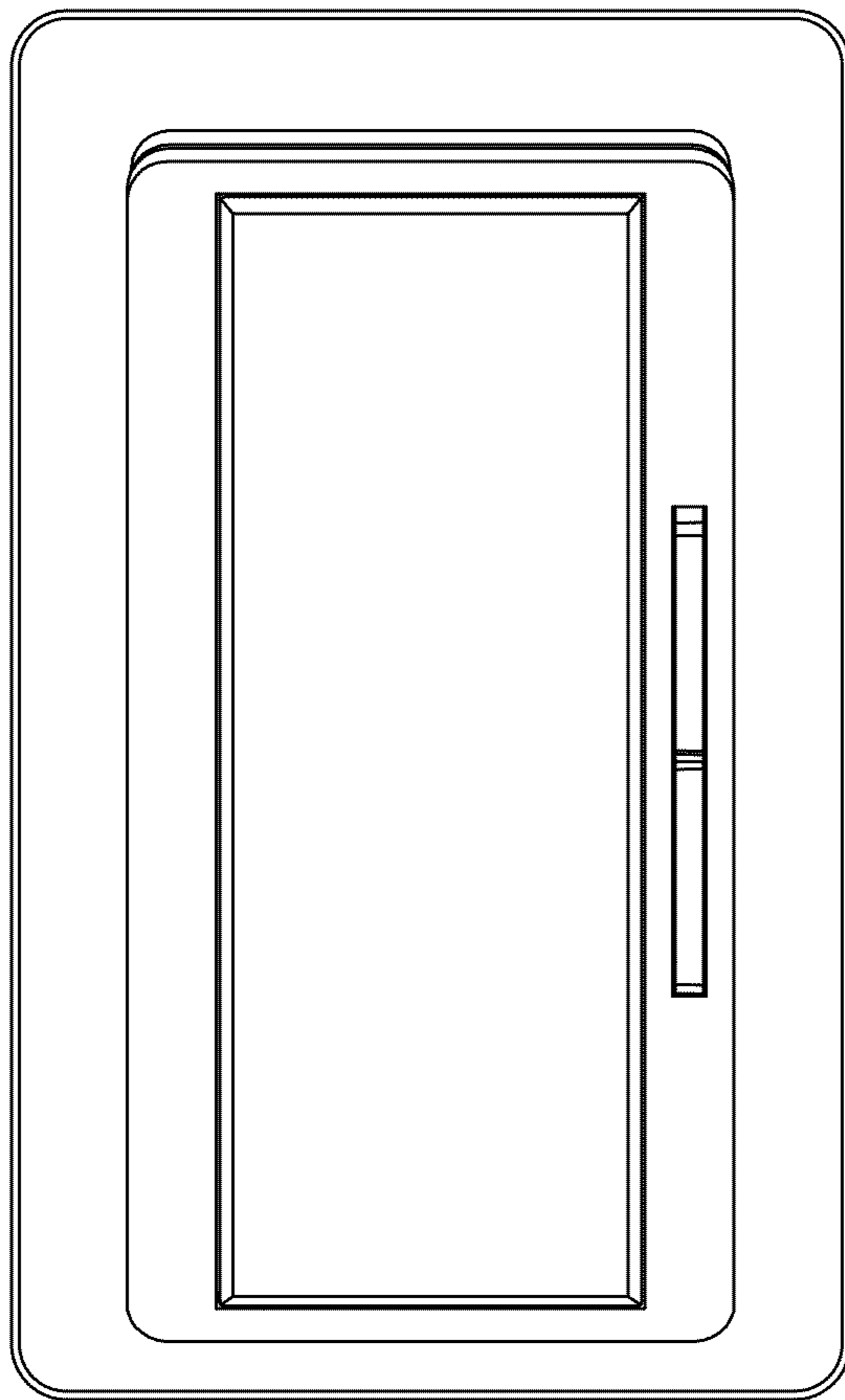

Fig. 8

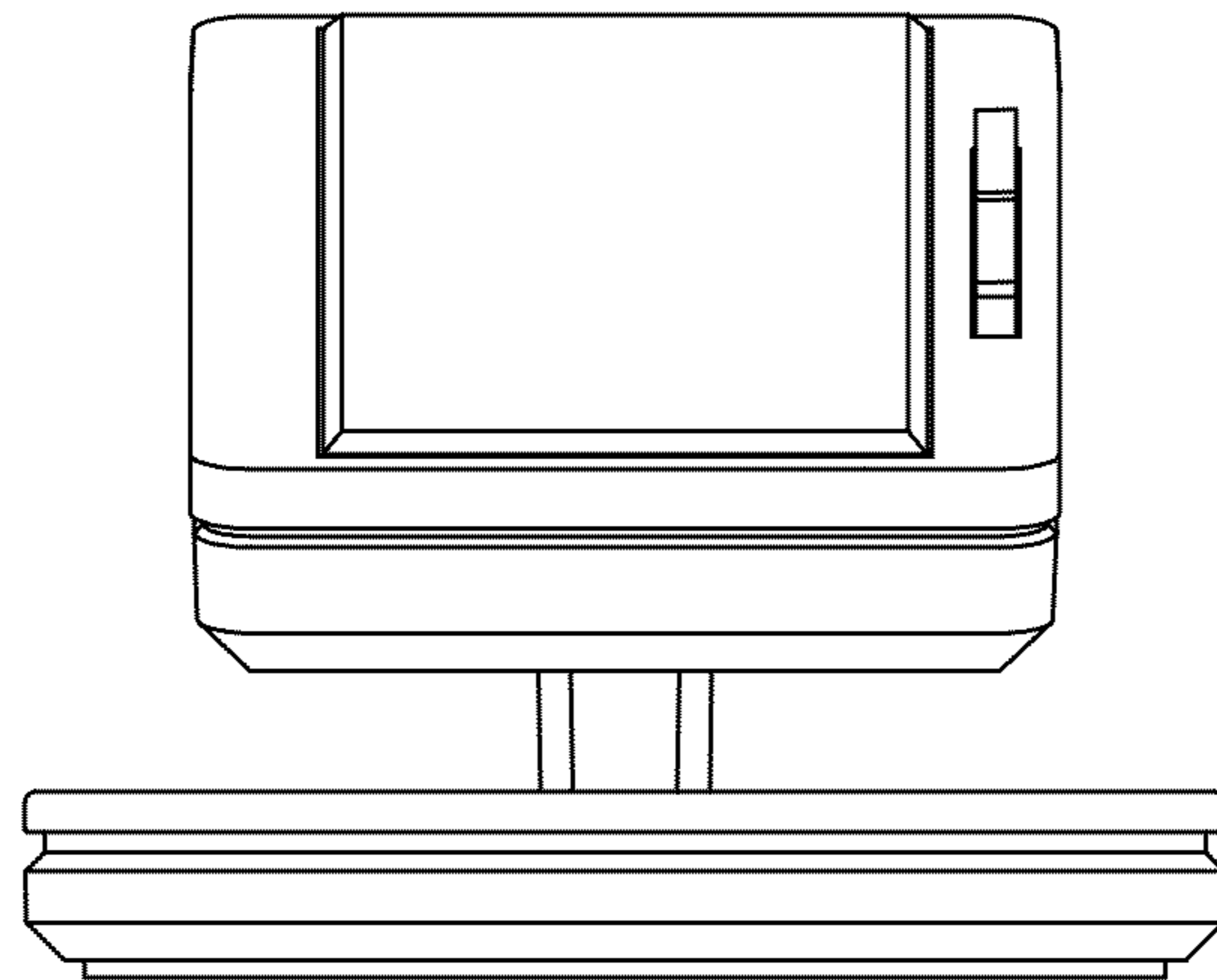

Fig. 9

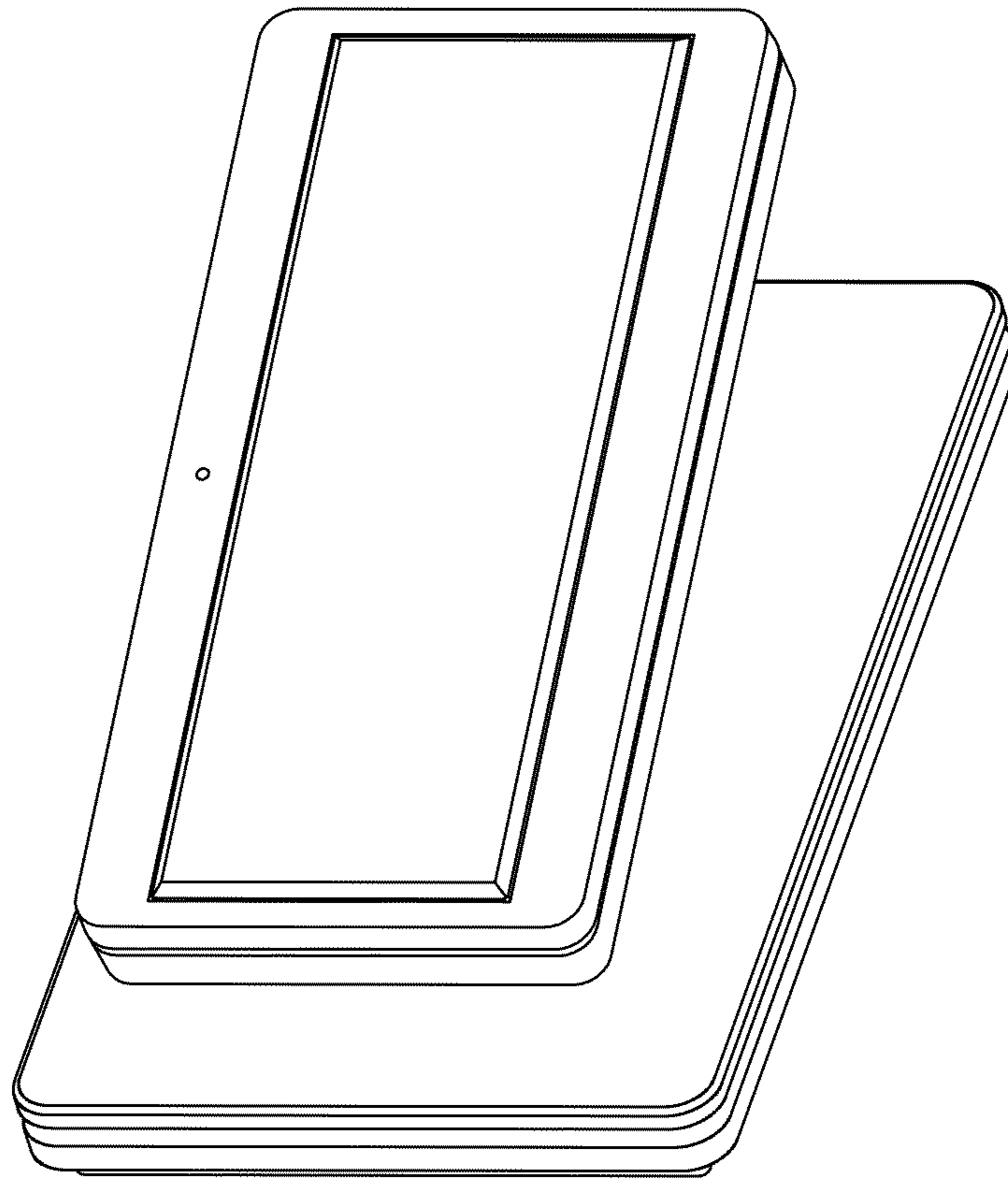

Fig. 10

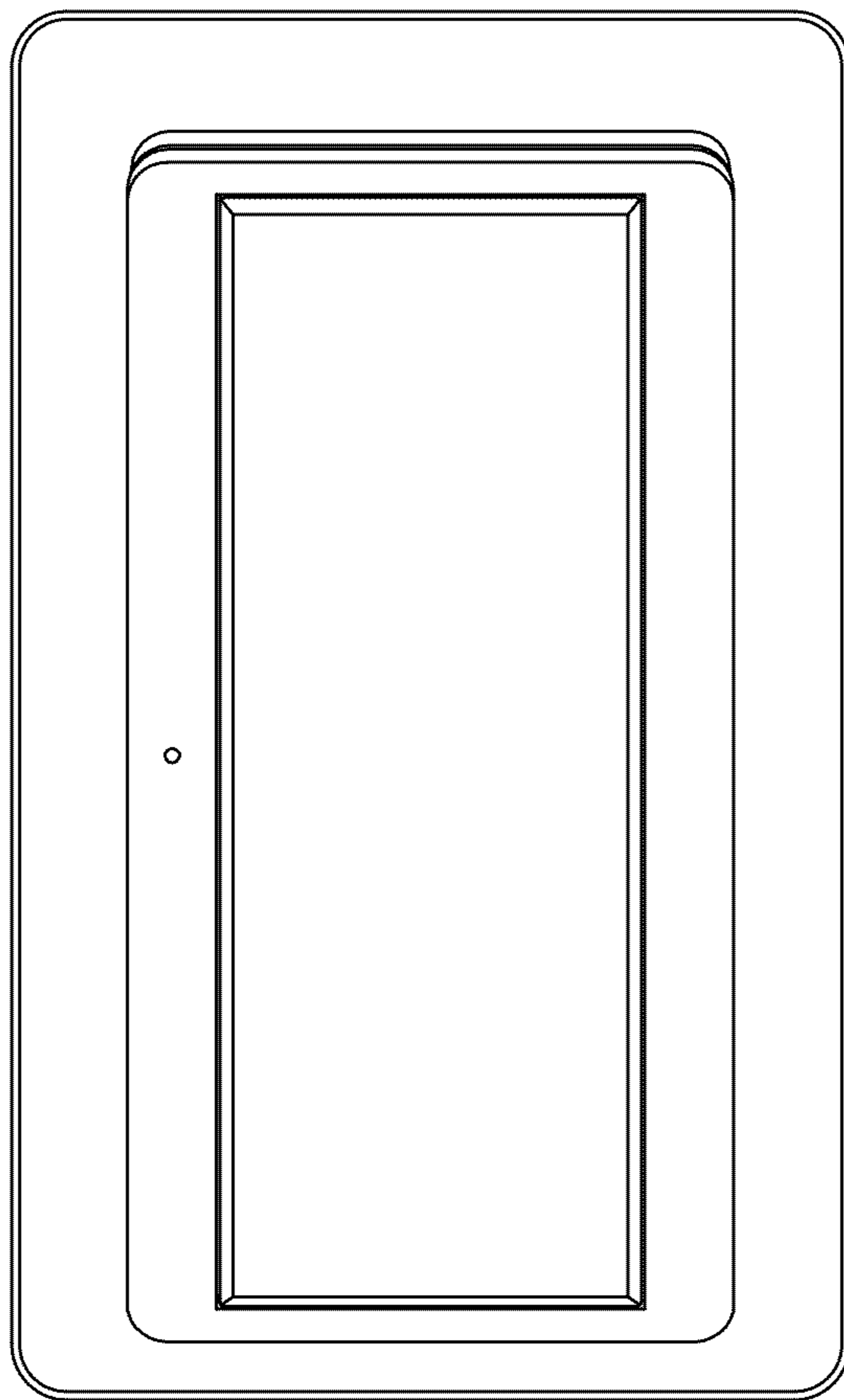

Fig. 11

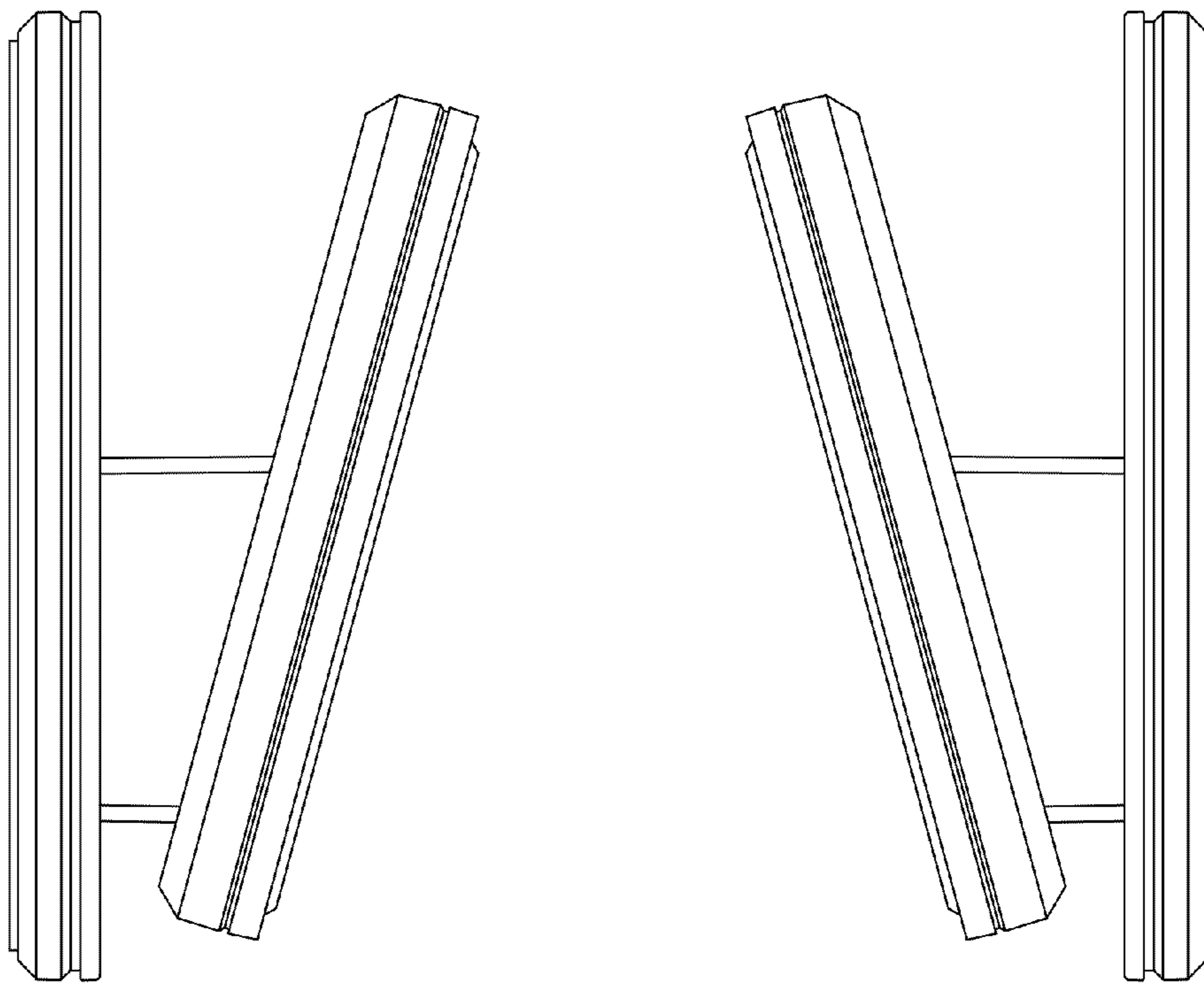

Fig. 12

Fig. 13

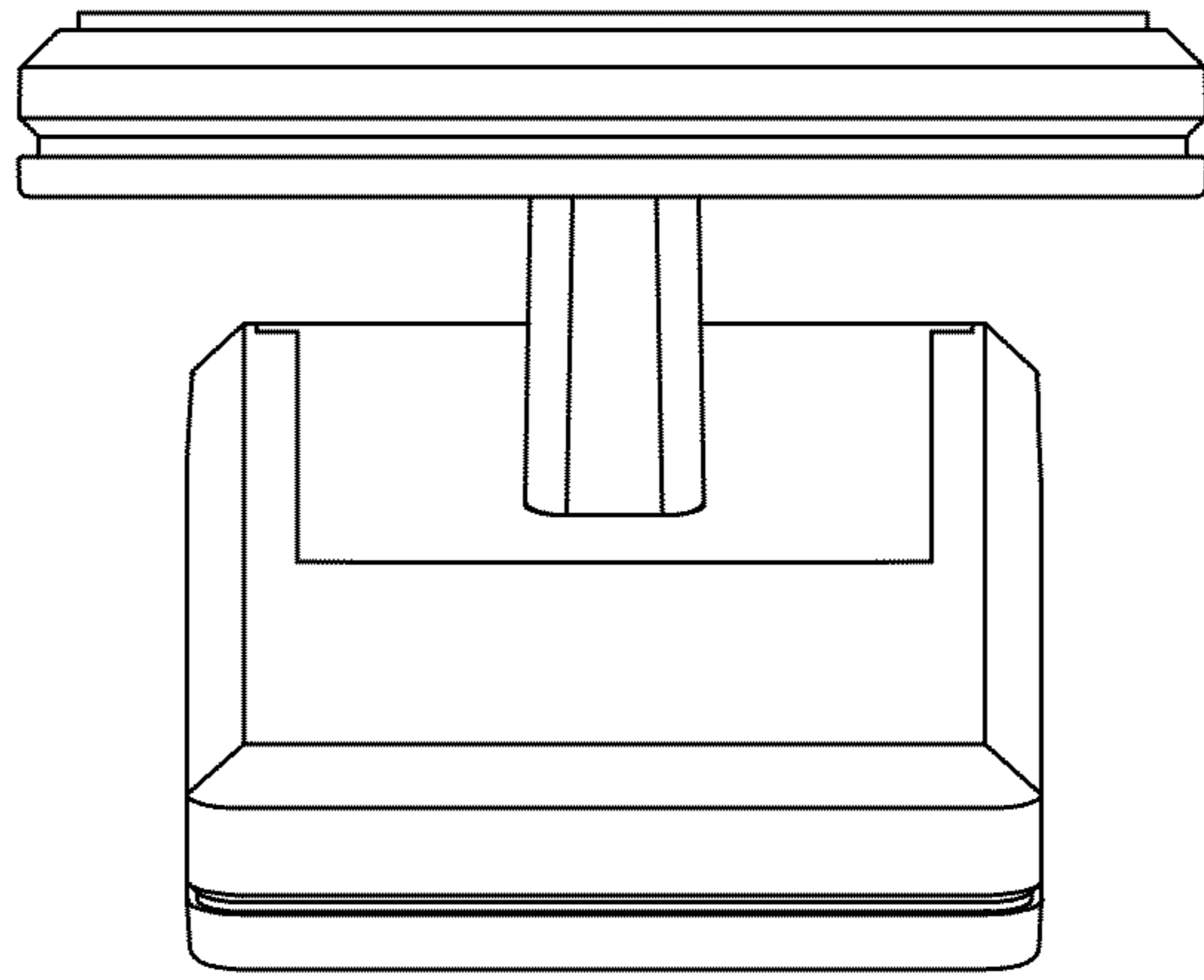

Fig. 14

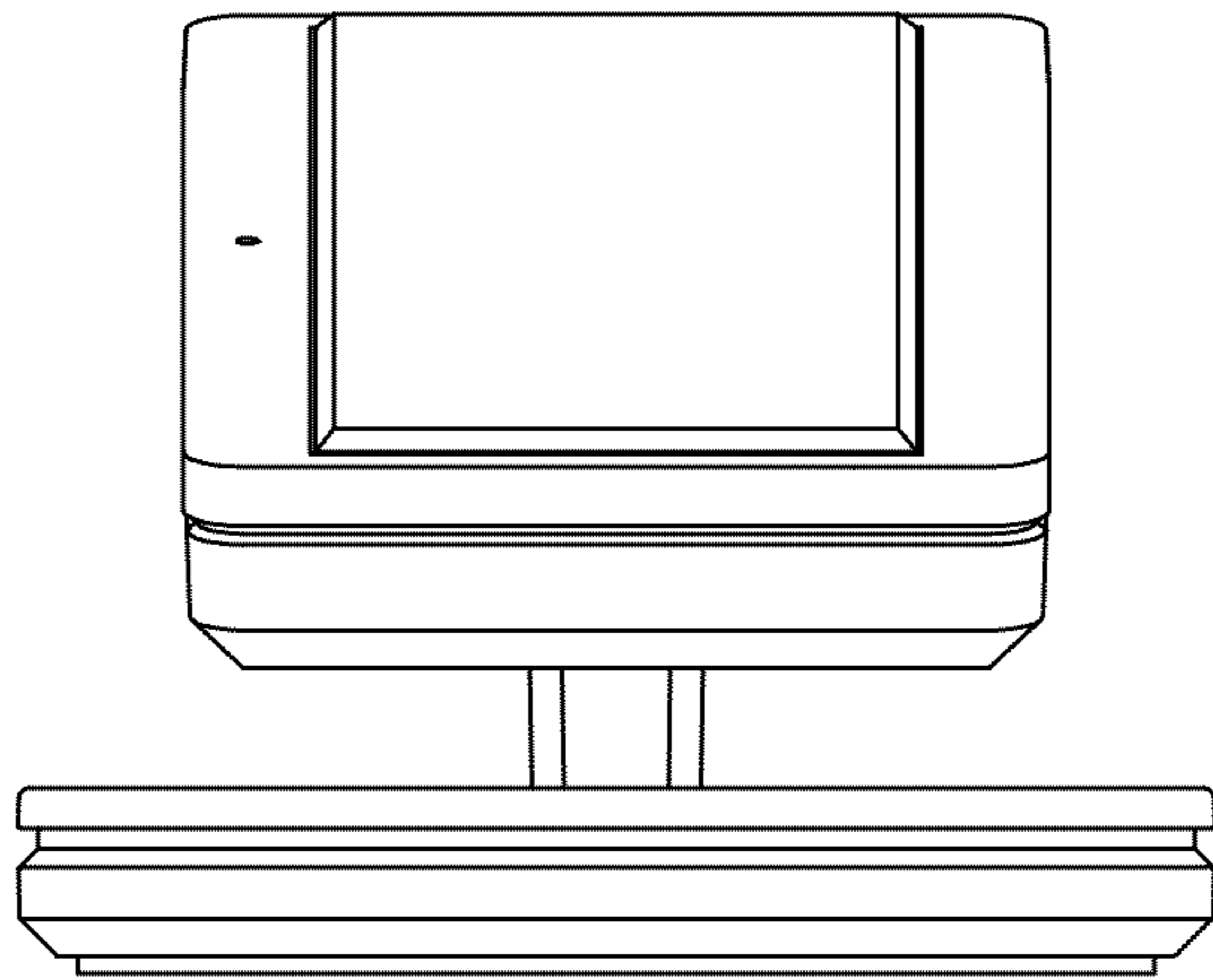

Fig. 15

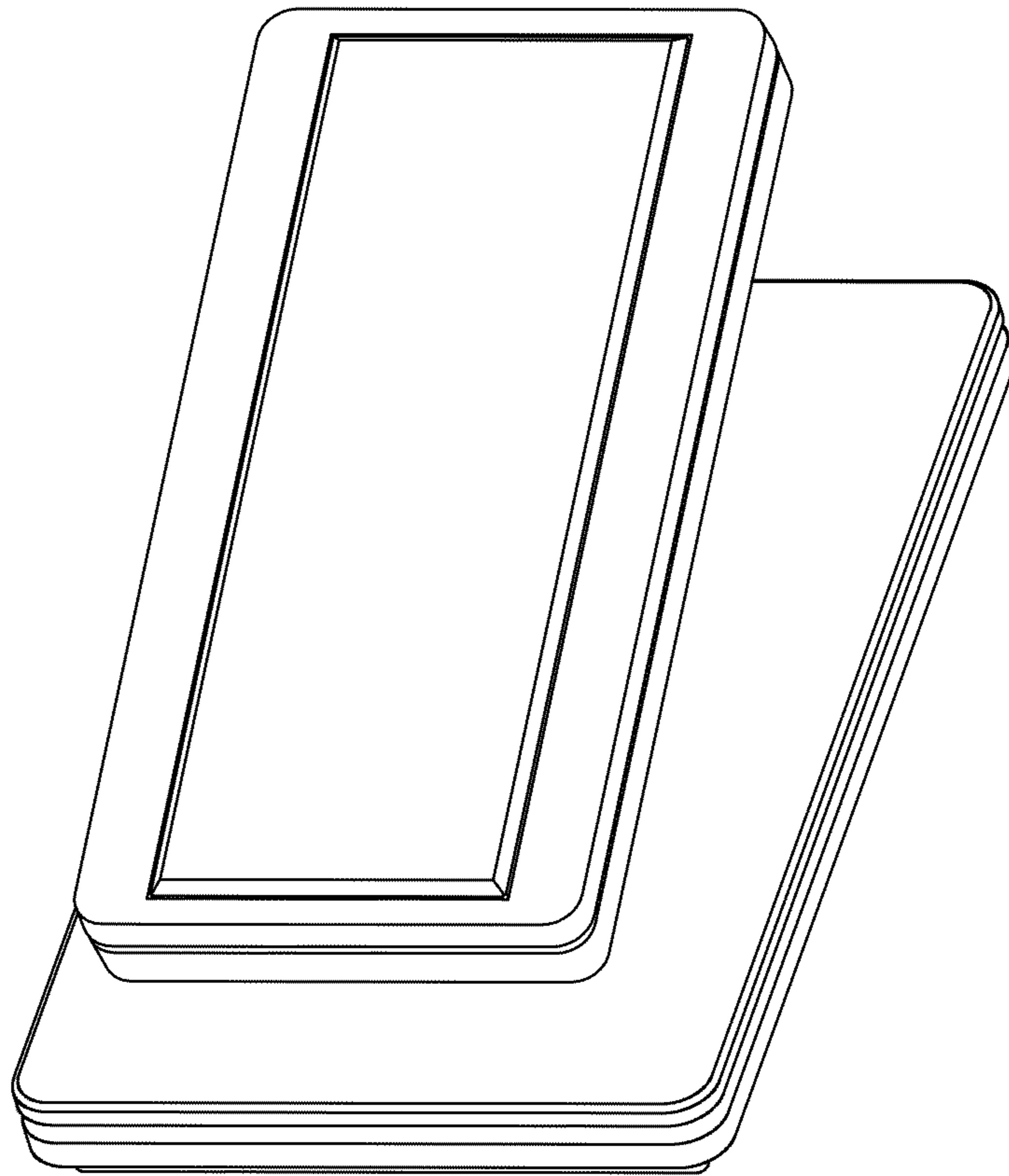

Fig. 16

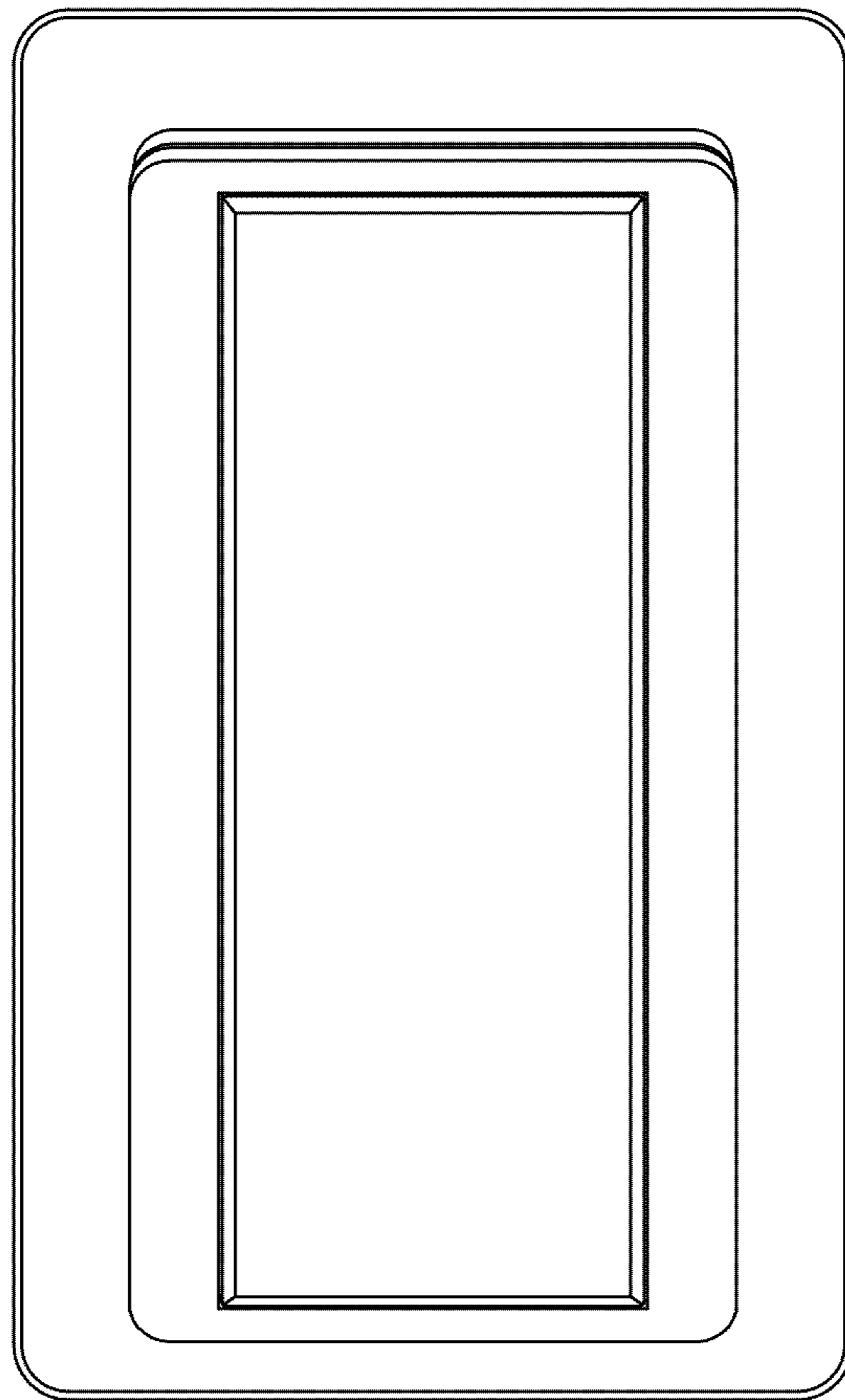

Fig. 17

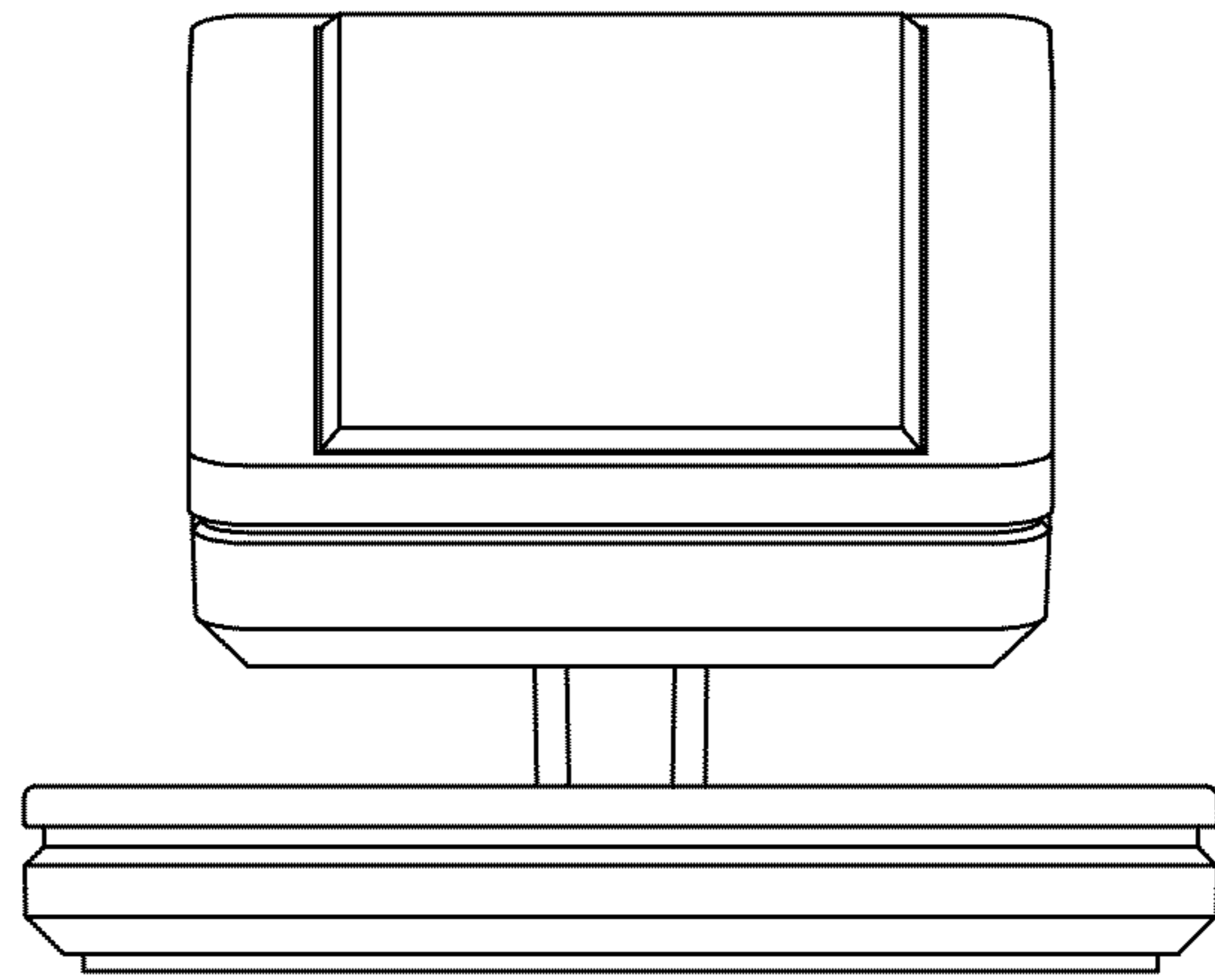

Fig. 18

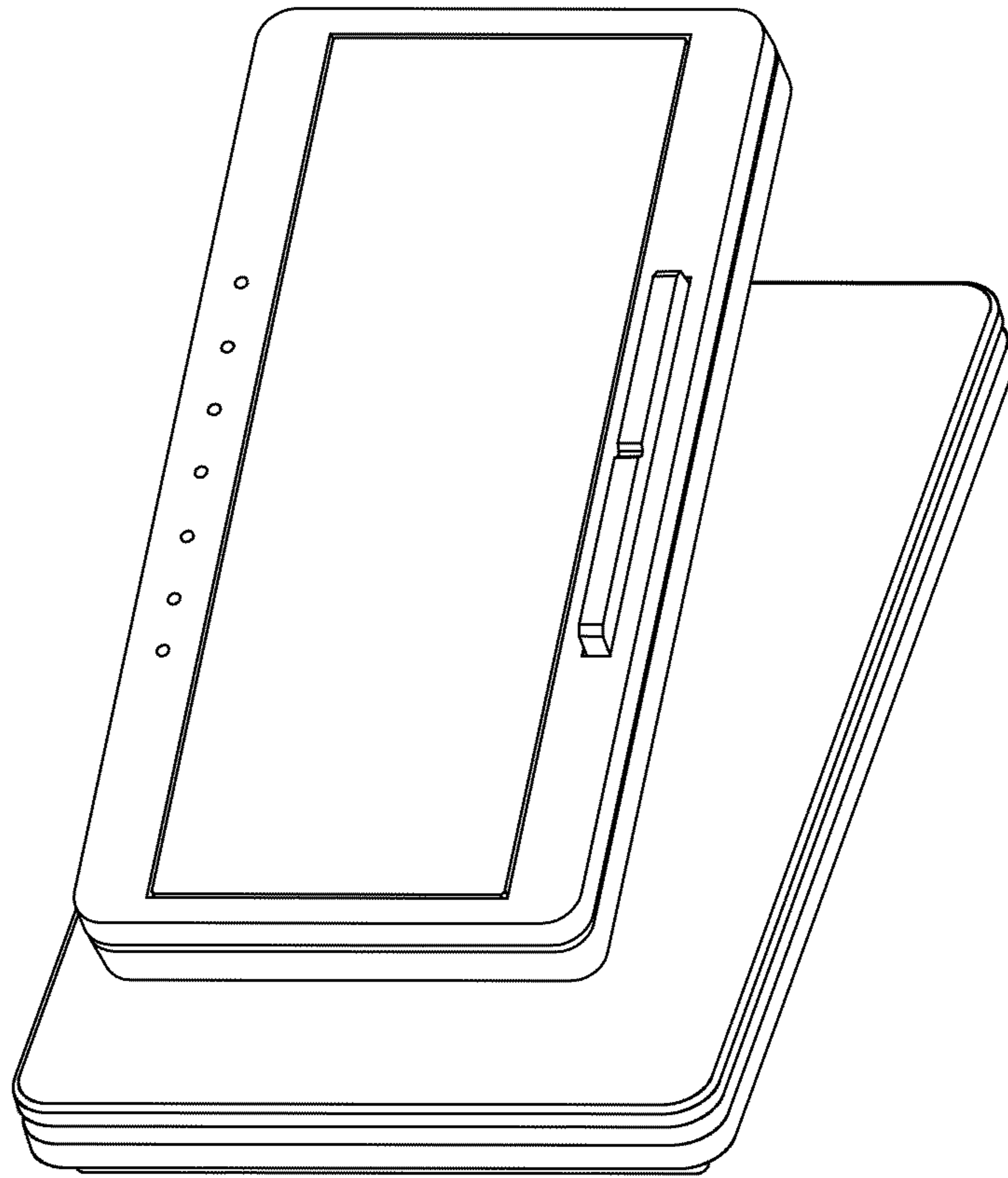

Fig. 19

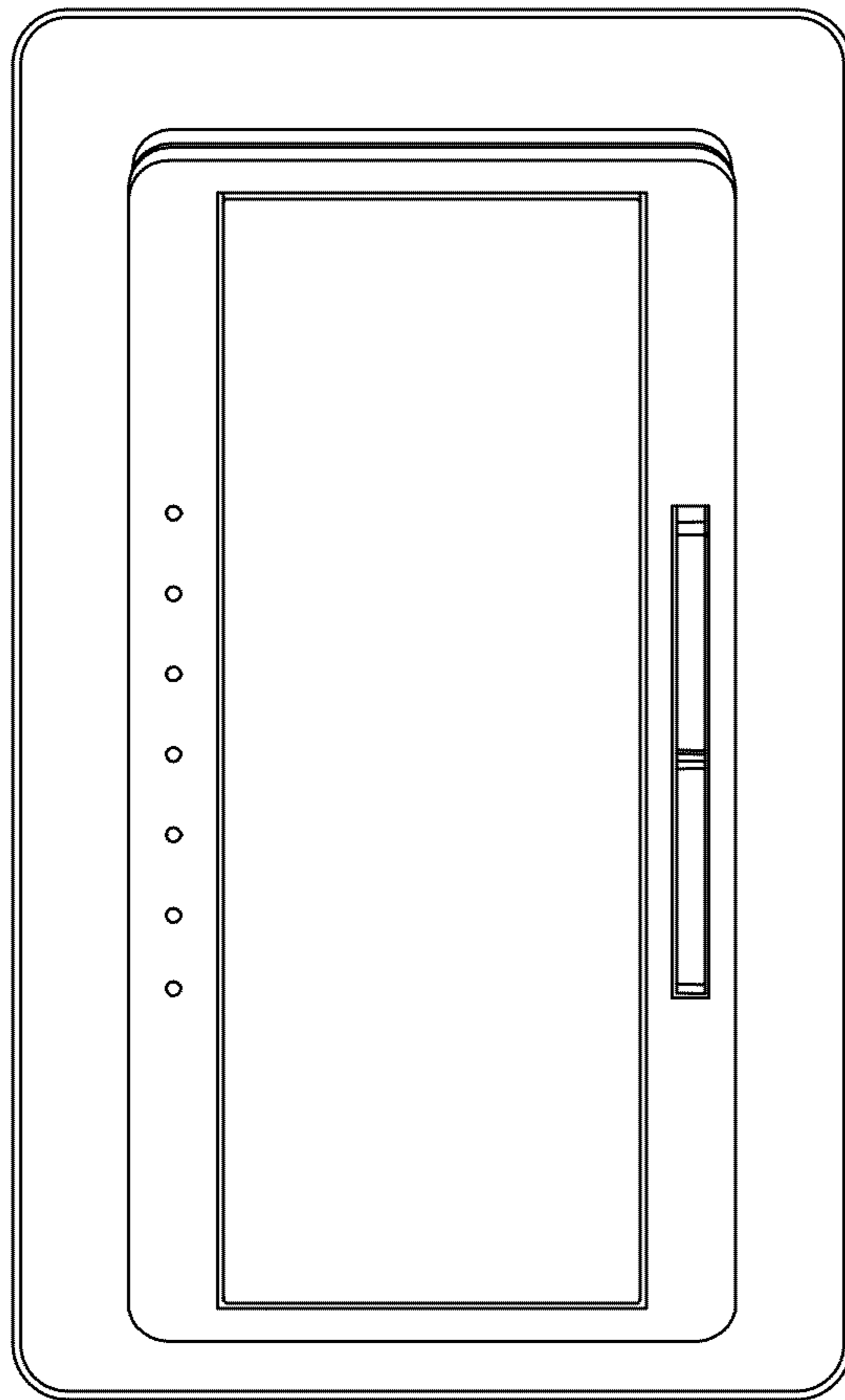

Fig. 20

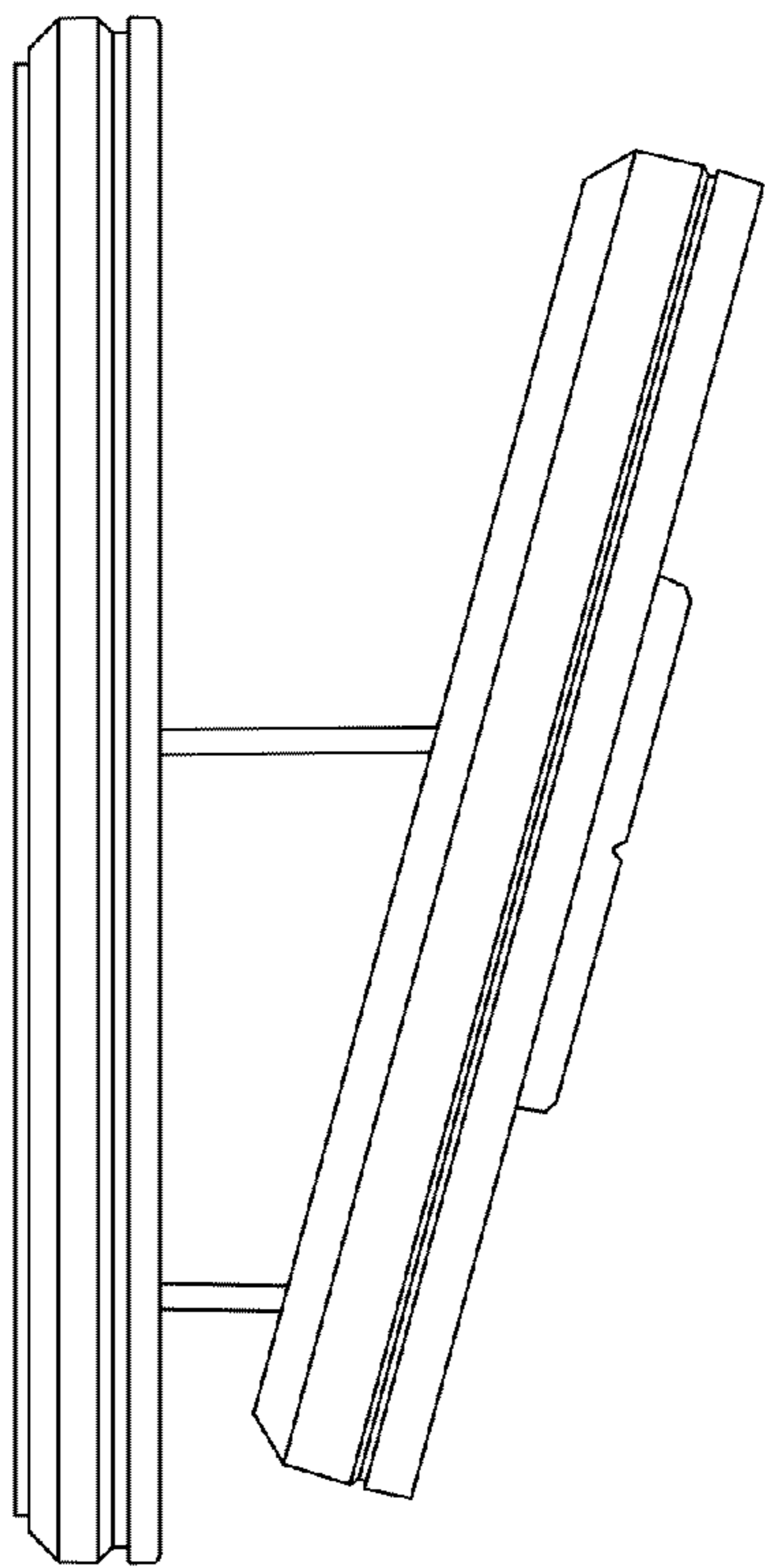

Fig. 21

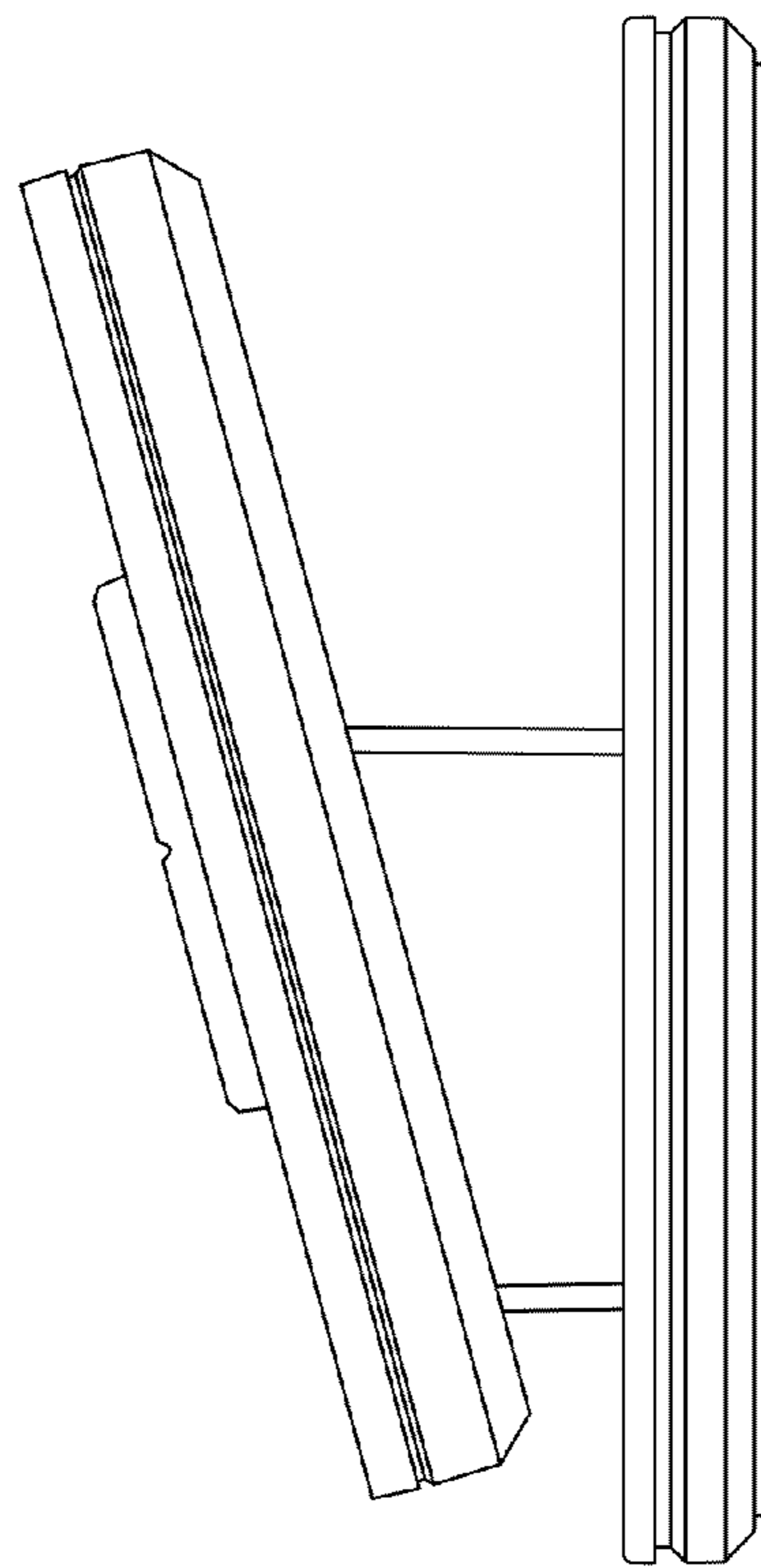

Fig. 22

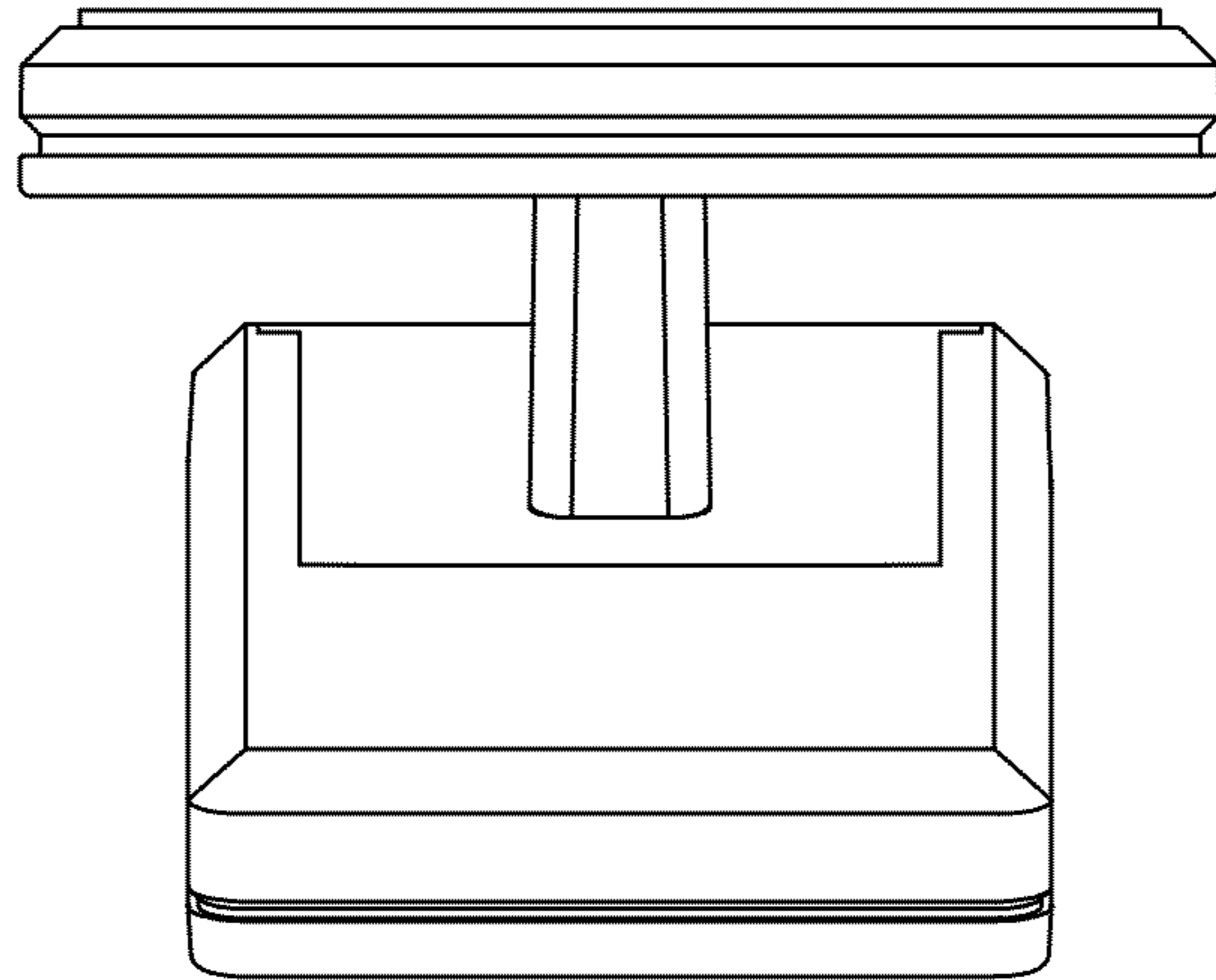

Fig. 23

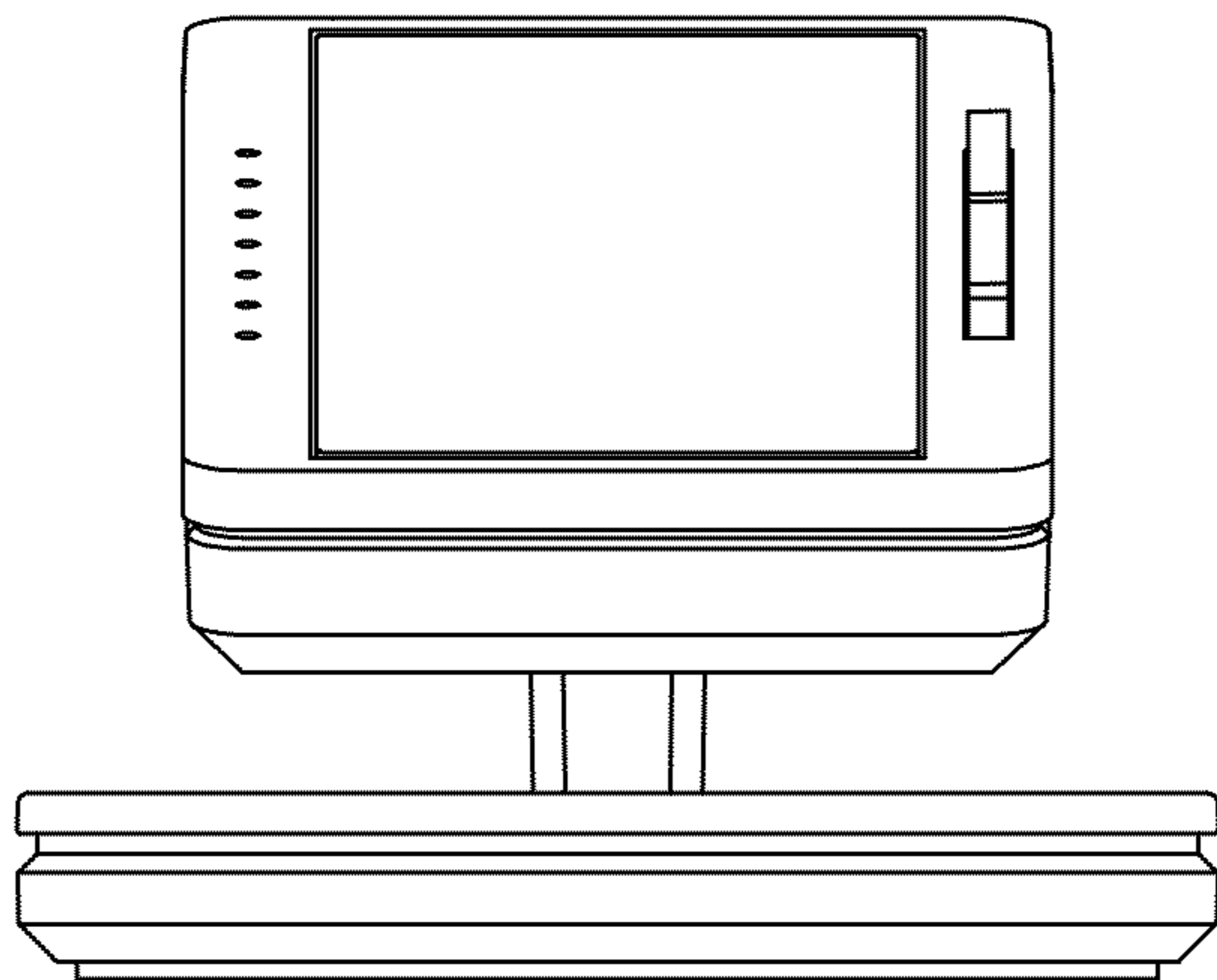

Fig. 24

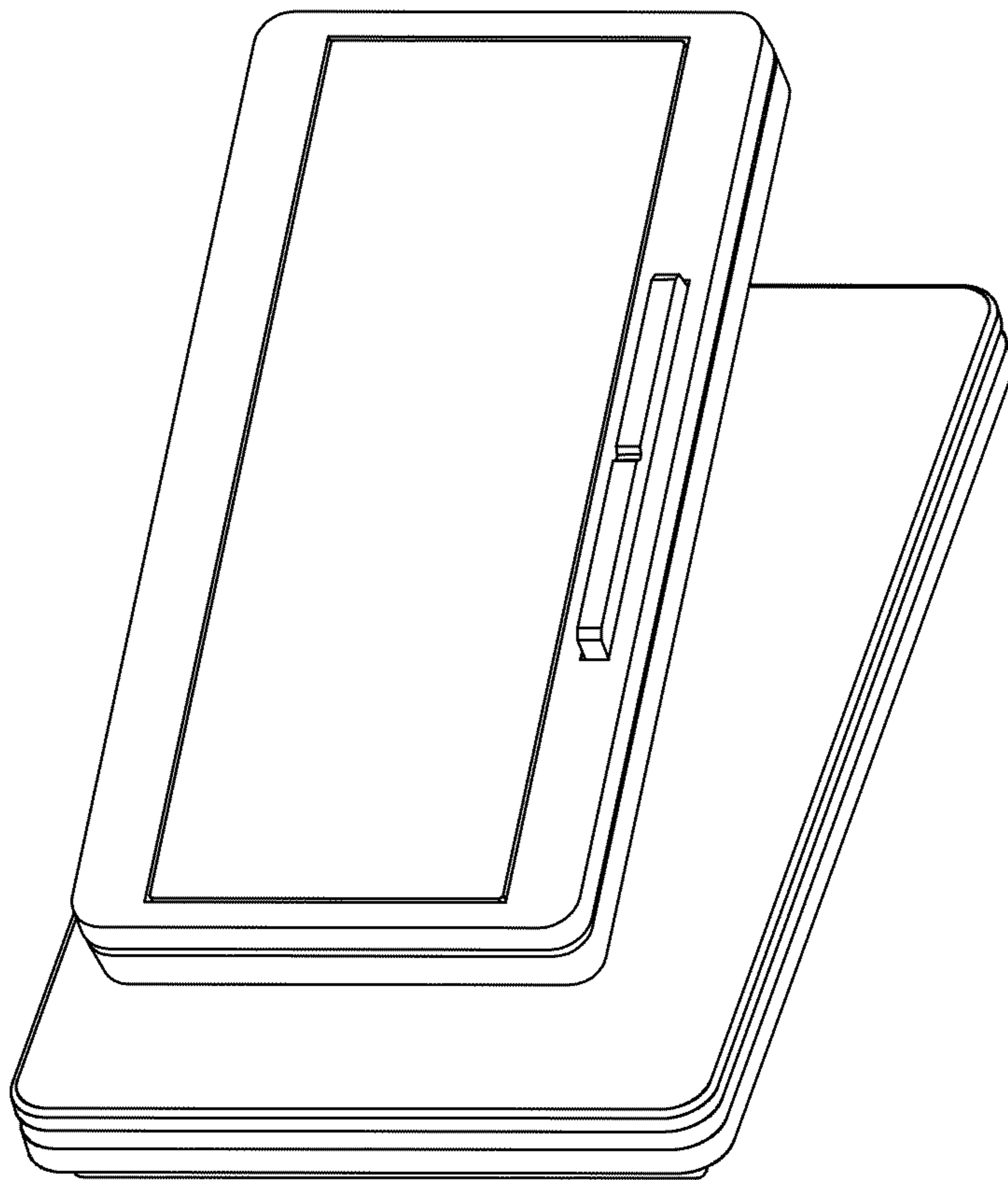

Fig. 25

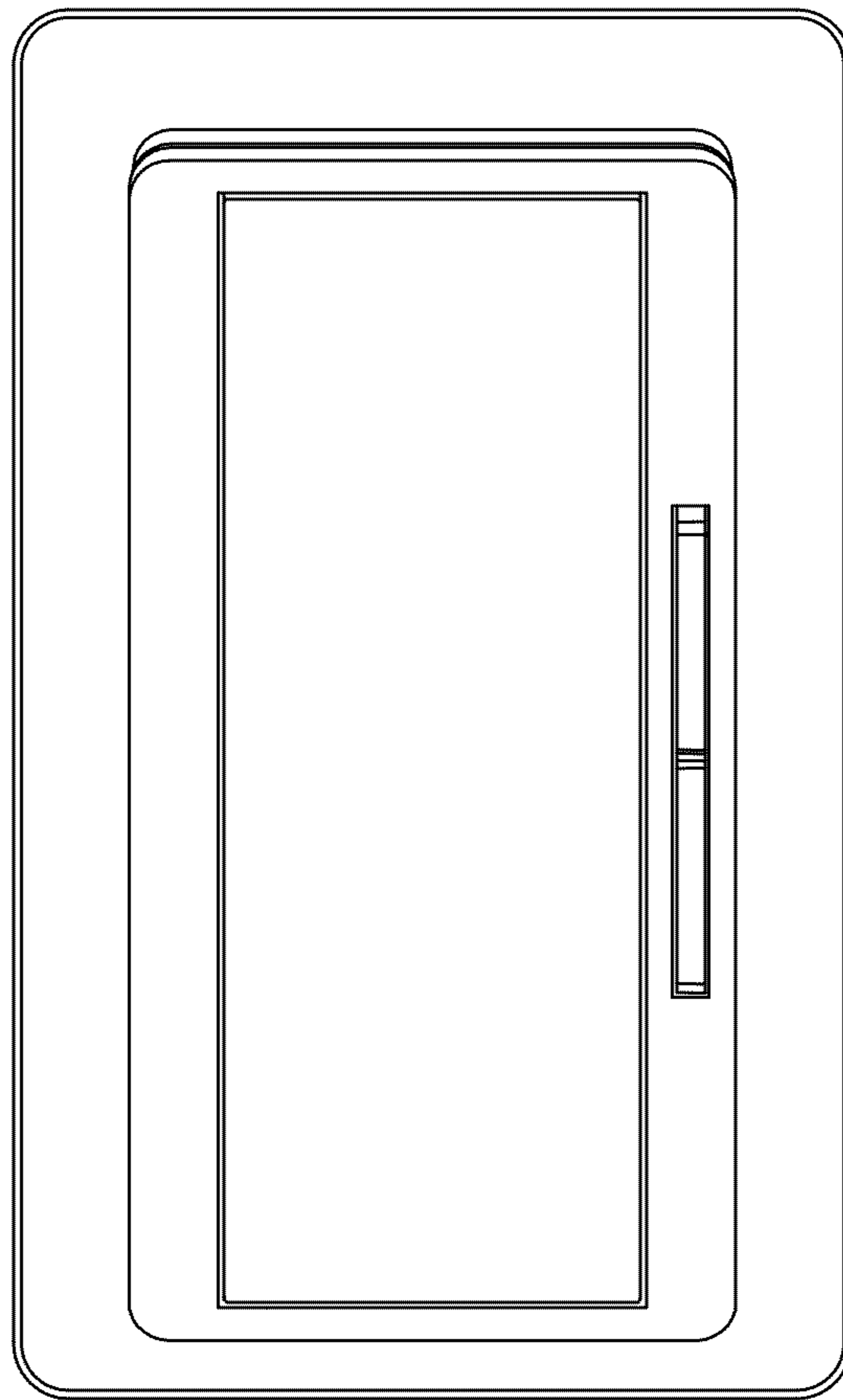

Fig. 26

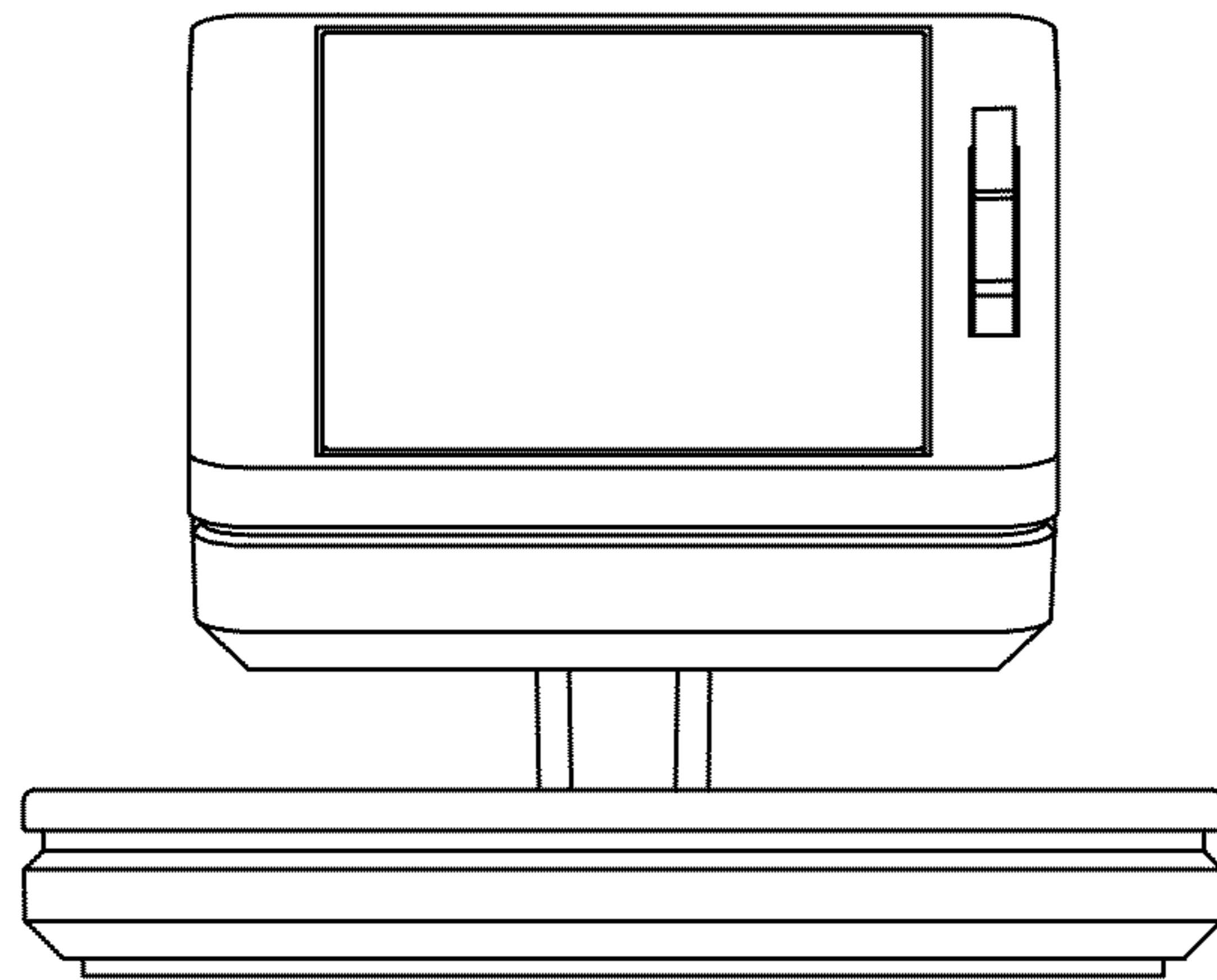

Fig. 27

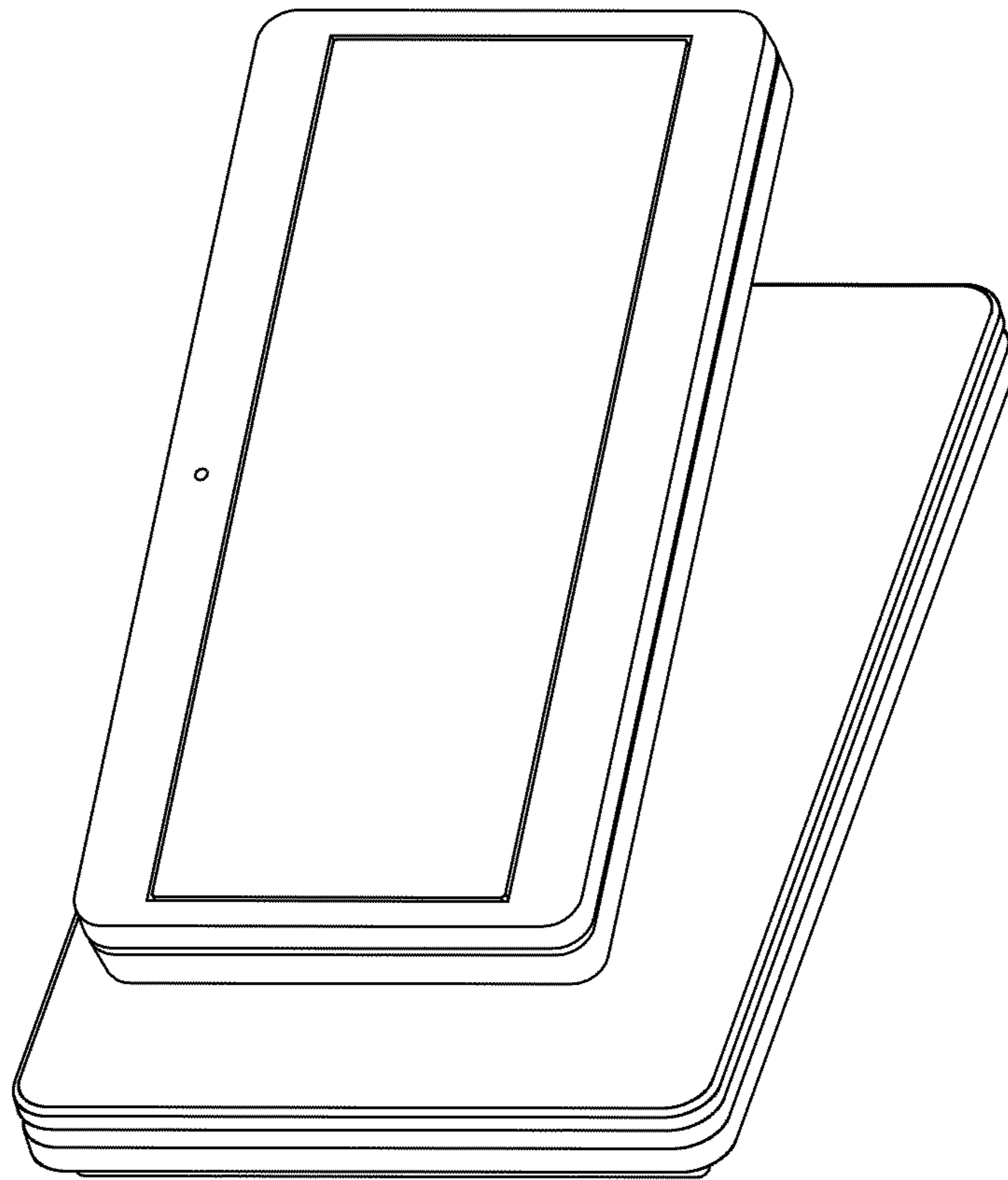

Fig. 28

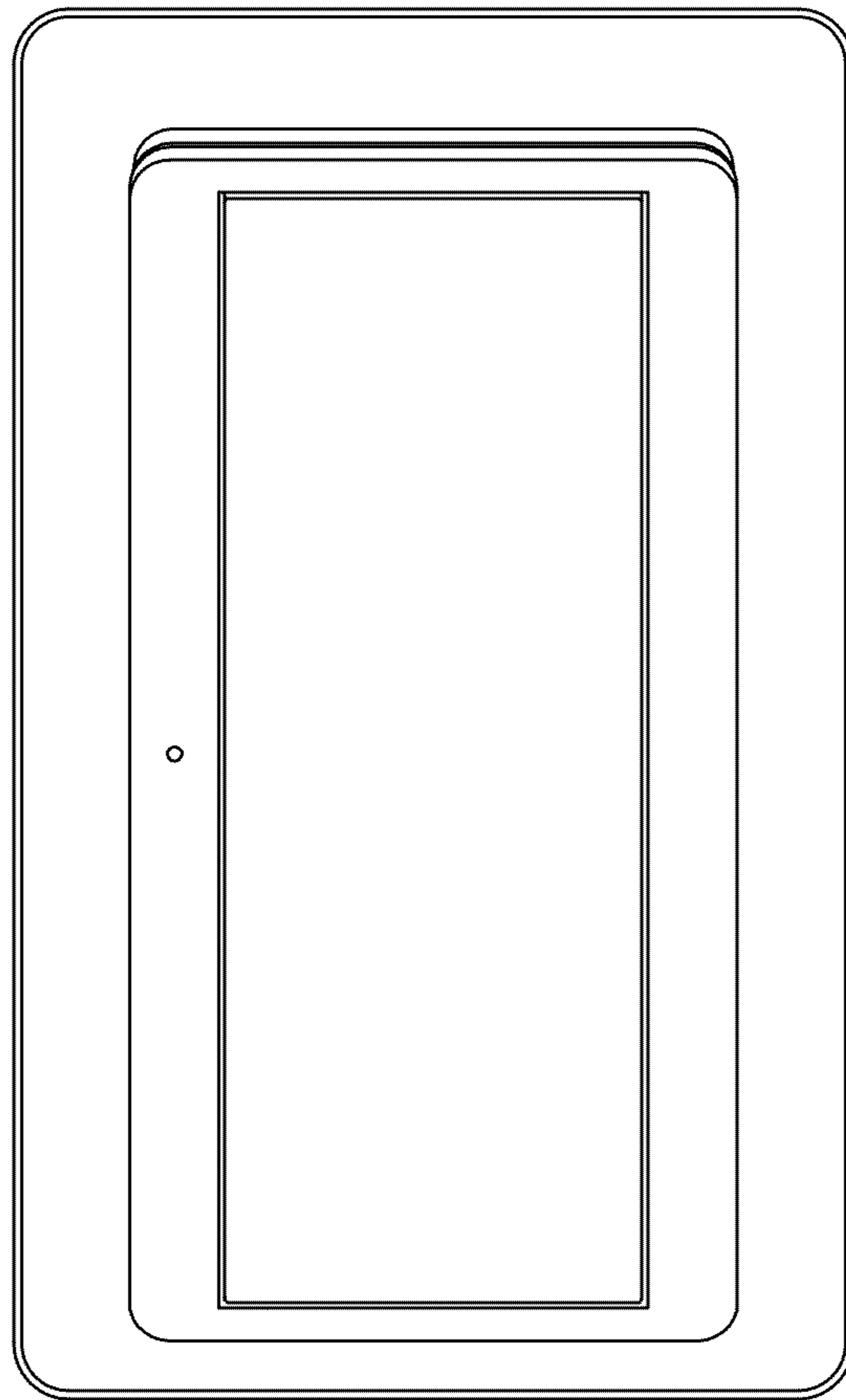

Fig. 29

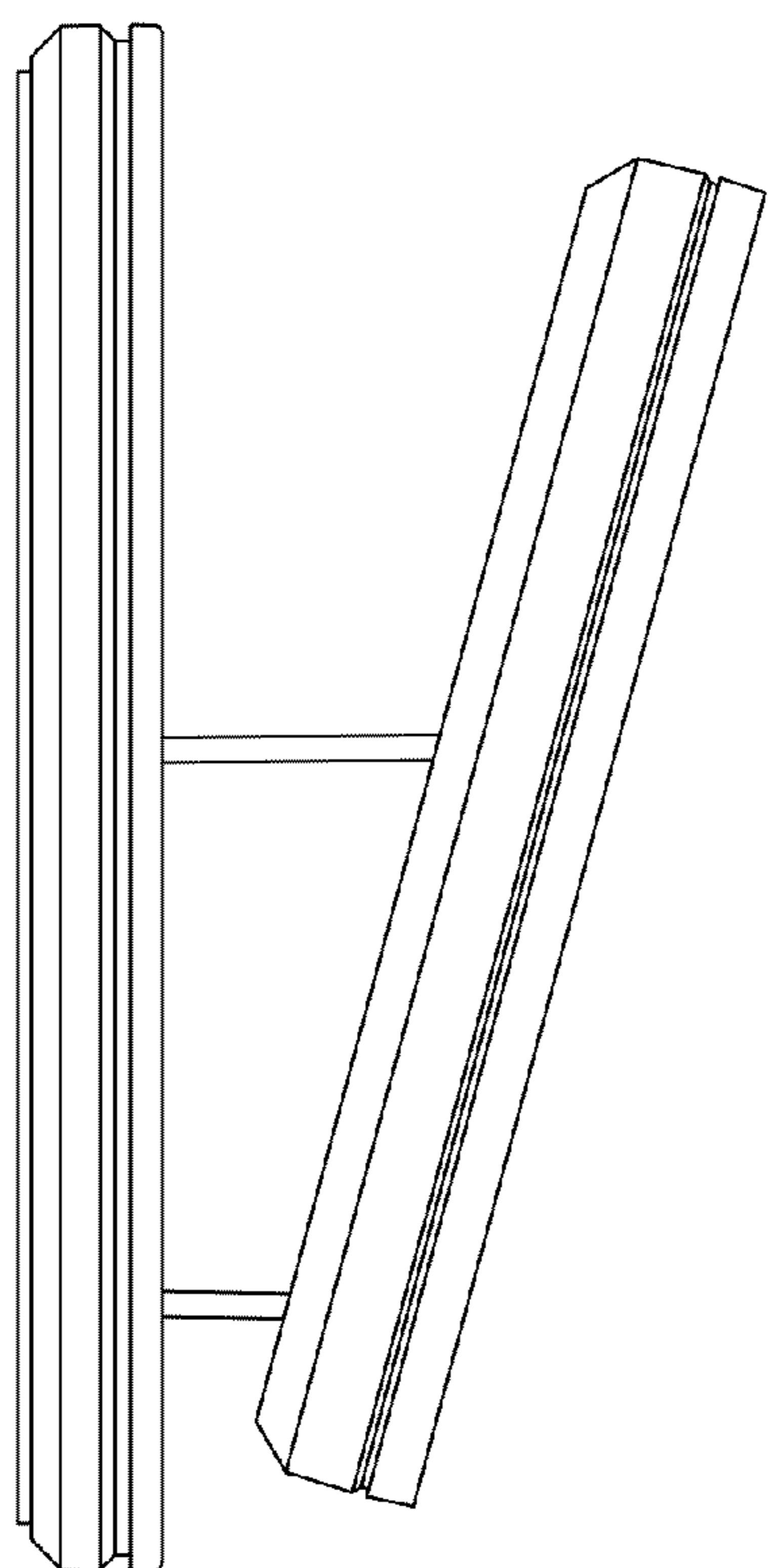

Fig. 30

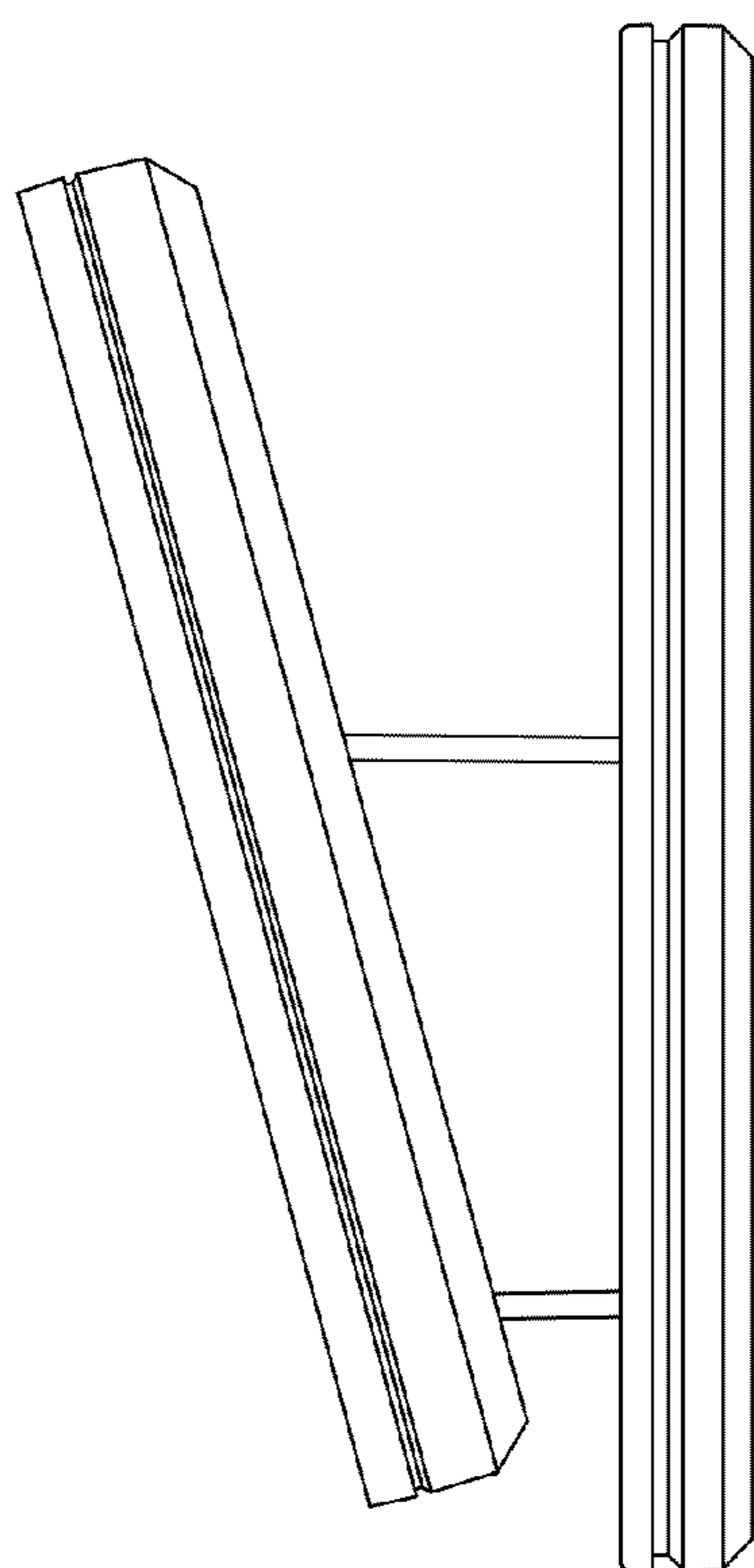

Fig. 31

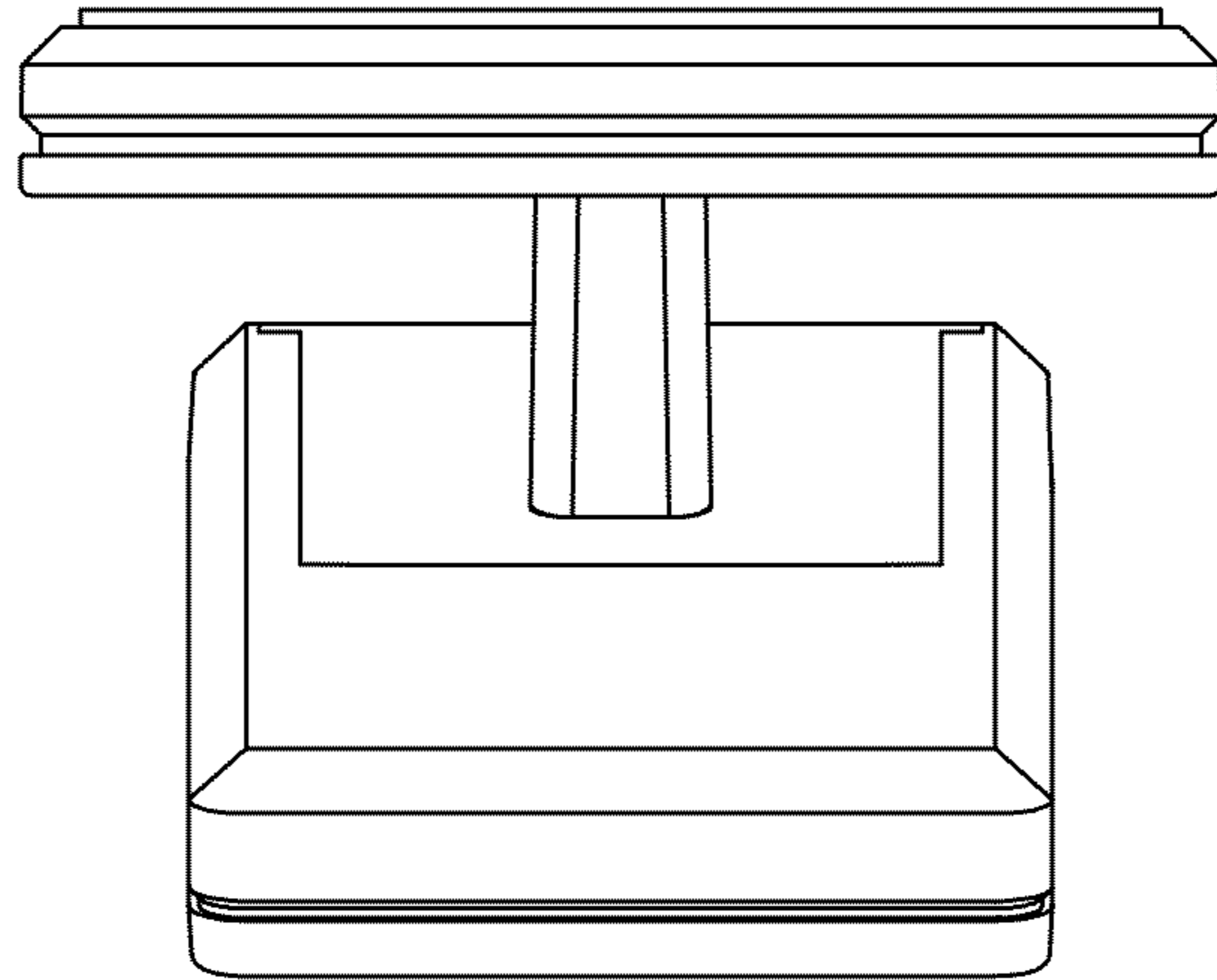

Fig. 32

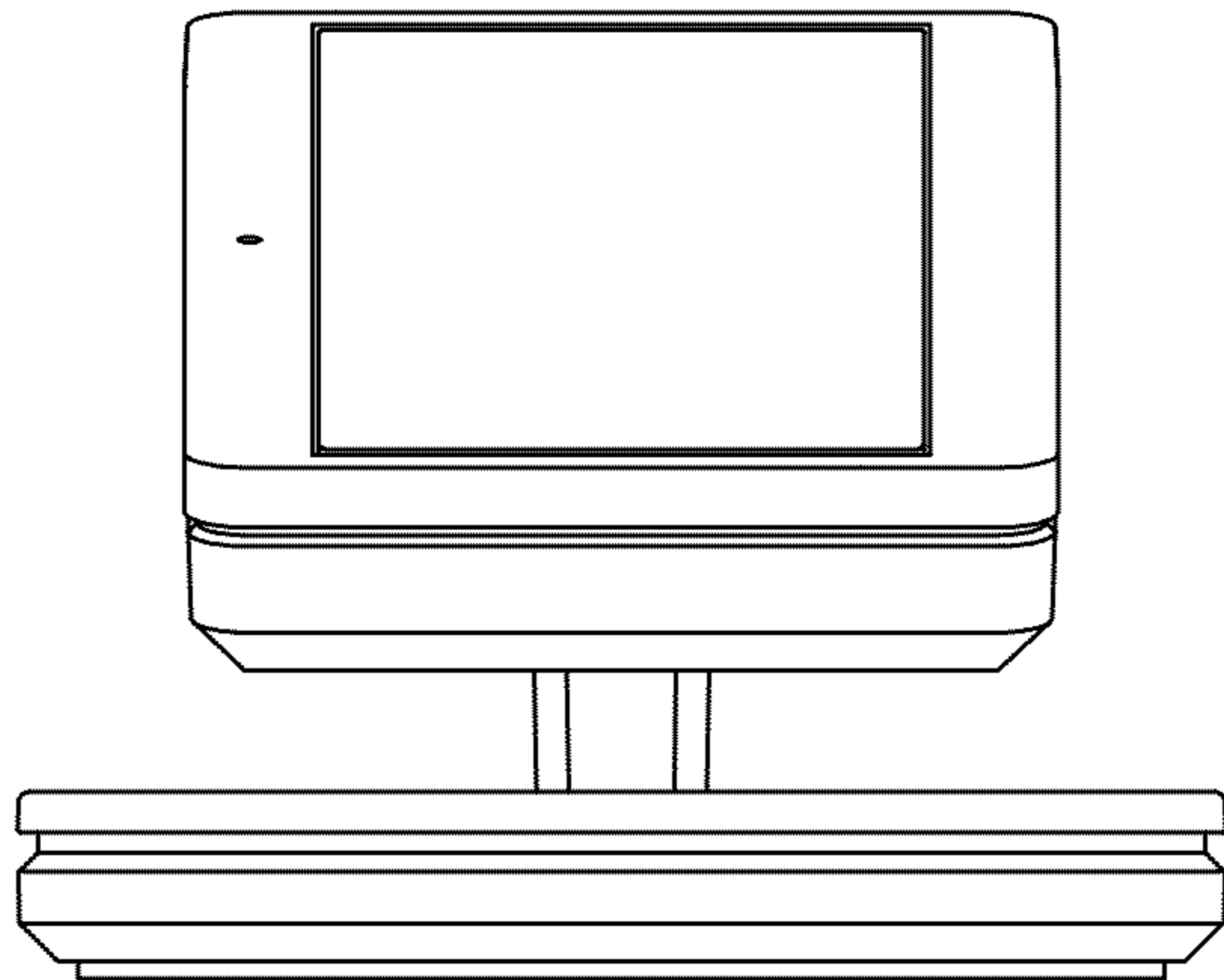

Fig. 33

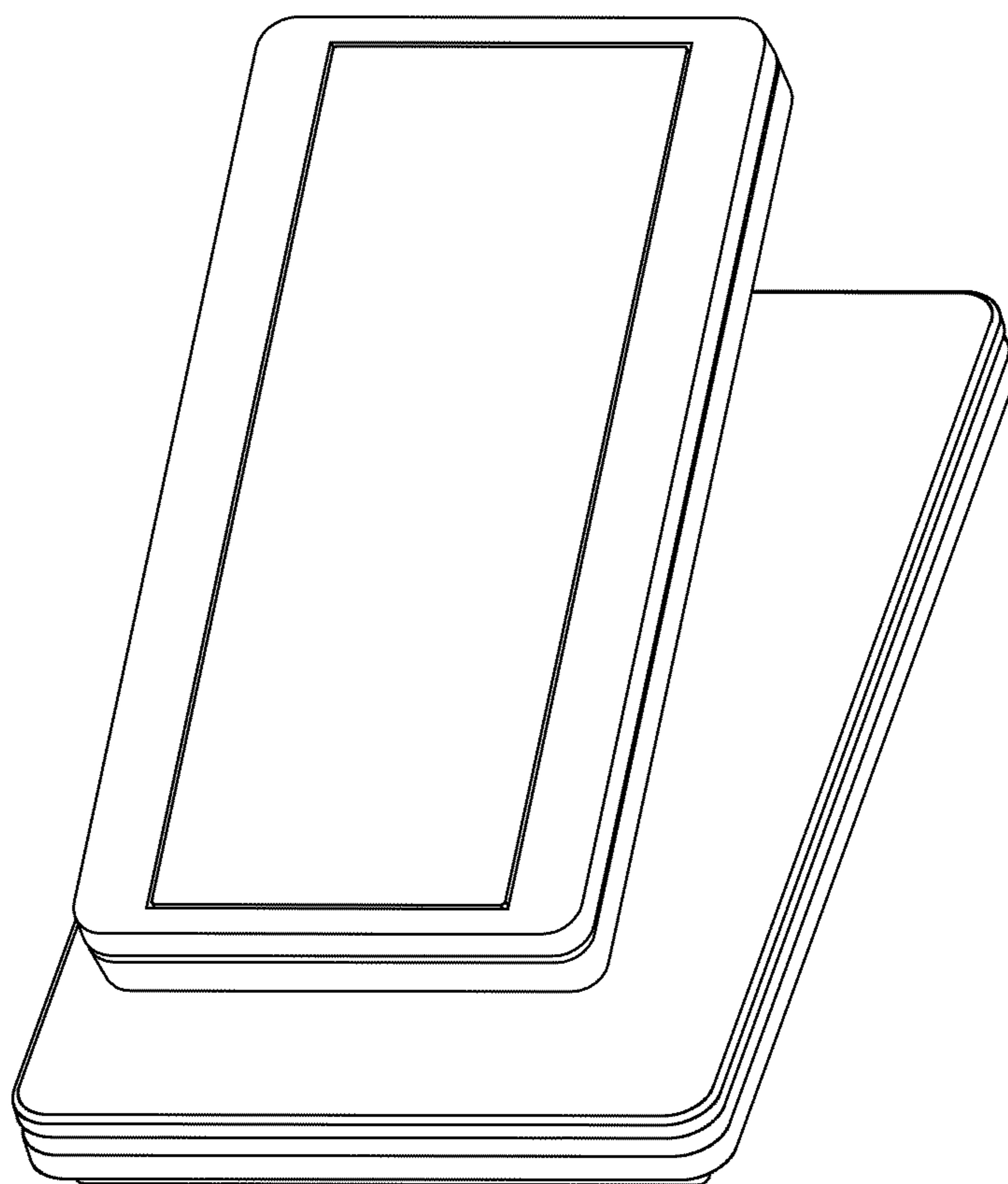

Fig. 34

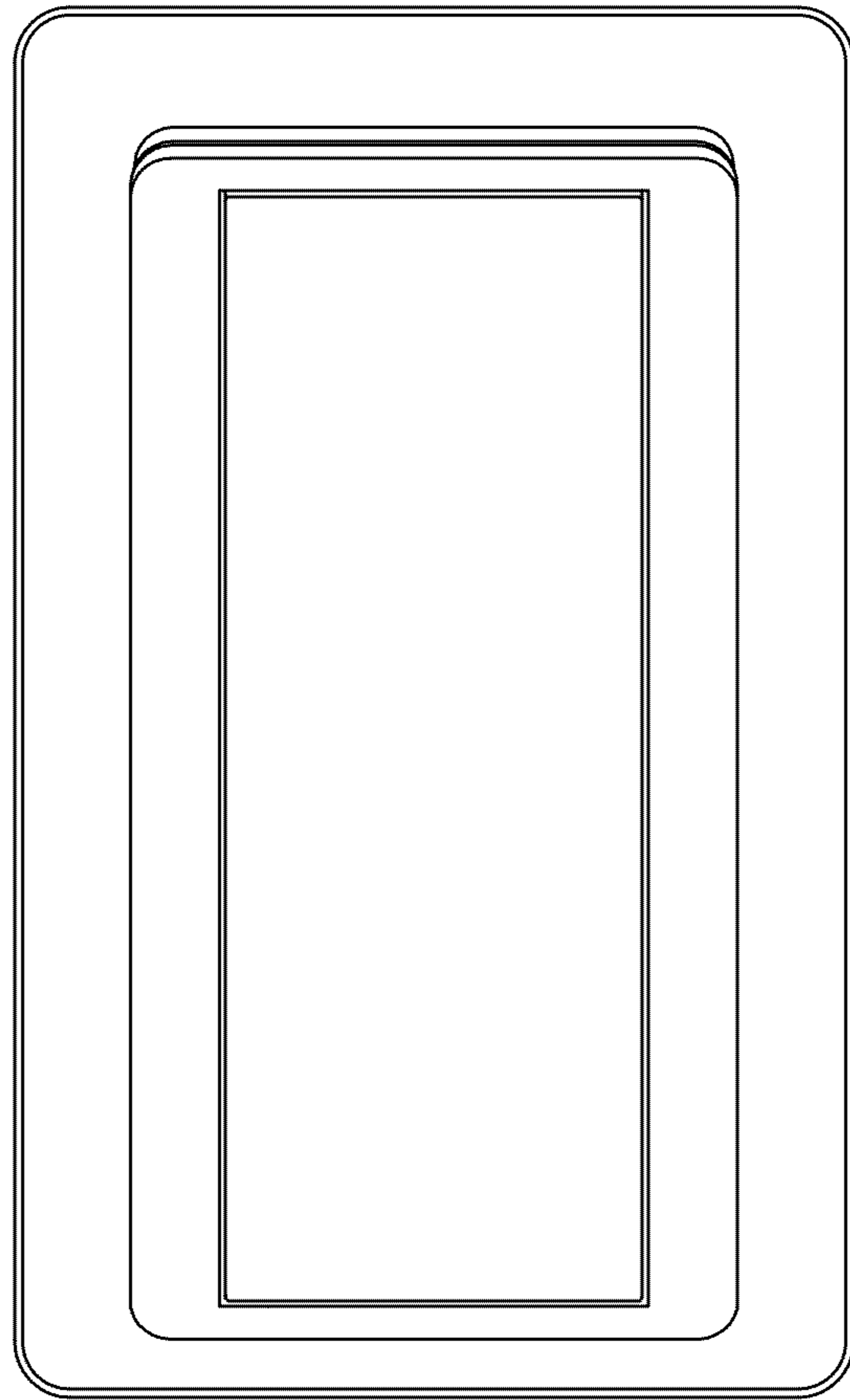

Fig. 35

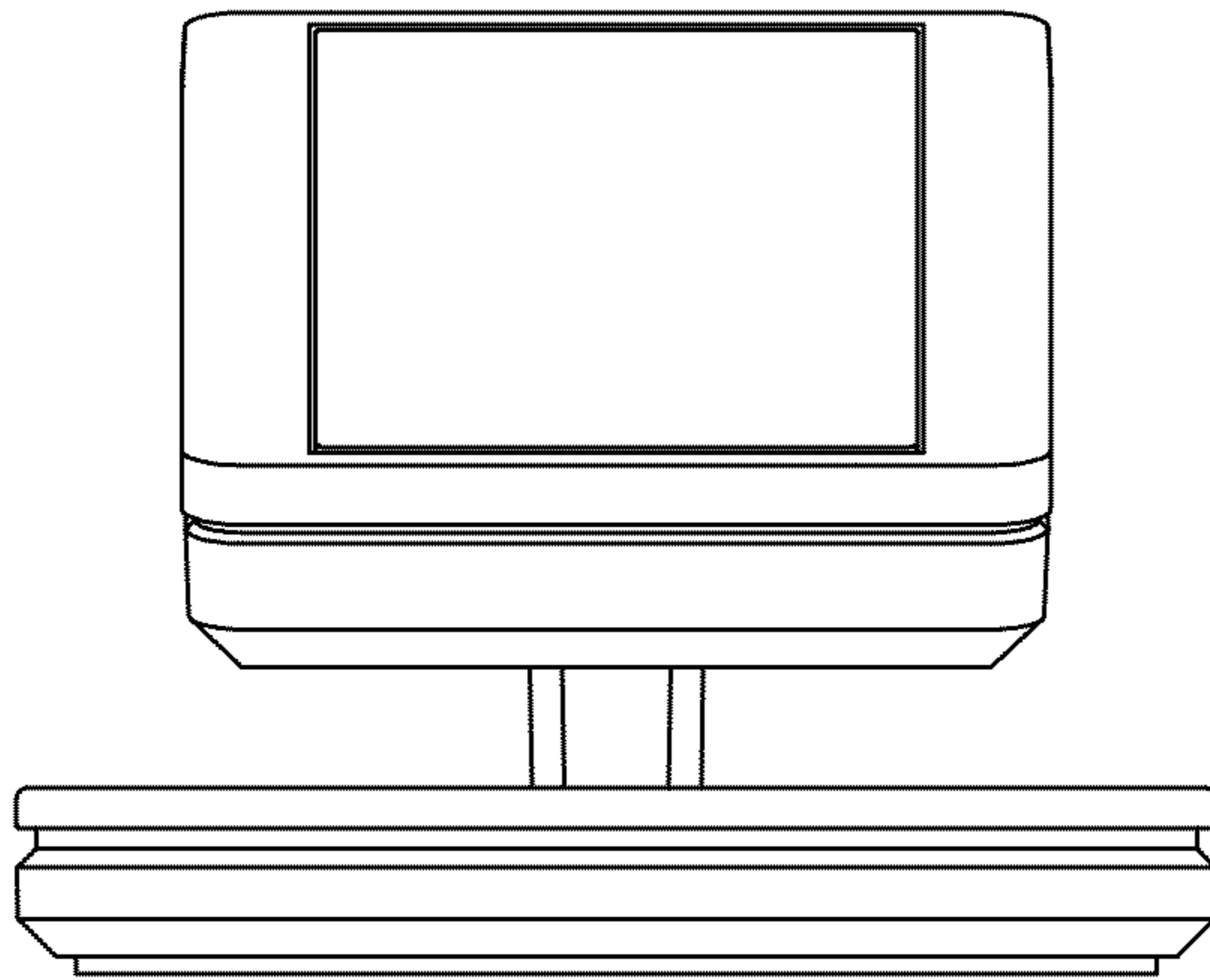

Fig. 36