



US00D692096S

(12) **United States Design Patent**
Fukano et al.

(10) **Patent No.:** **US D692,096 S**
(45) **Date of Patent:** **** Oct. 22, 2013**

(54) **VACUUM SUPPLY CONTROL VALVE
MANIFOLD**

(75) Inventors: **Yoshihiro Fukano**, Moriya (JP); **Koji Sugano**, Koshigaya (JP); **Masayoshi Yamamoto**, Koshigaya (JP)

(73) Assignee: **SMC Kabushiki Kaisha**, Tokyo (JP)

(**) Term: **14 Years**

(21) Appl. No.: **29/404,626**

(22) Filed: **Oct. 24, 2011**

(30) **Foreign Application Priority Data**

Apr. 25, 2011 (JP) 2011-009501

(51) **LOC (9) Cl.** **23-01**

(52) **U.S. Cl.**
USPC **D23/233**

(58) **Field of Classification Search**
USPC D23/233-237, 244-249; D15/5, 7, 199;
137/554, 557, 882, 884, 343, 625.64,
137/269, 271; 251/12, 130, 129.04, 219,
251/331

See application file for complete search history.

(56) **References Cited**

U.S. PATENT DOCUMENTS

5,810,115 A * 9/1998 Mismas 184/7.4
D409,279 S * 5/1999 Hayashi et al. D23/233
D427,663 S * 7/2000 Hayashi et al. D23/233
D443,030 S * 5/2001 Kaneko et al. D23/233
7,096,889 B1 * 8/2006 Roys 137/884
D532,865 S * 11/2006 Miyazoe et al. D23/233
D533,628 S * 12/2006 Miyazoe et al. D23/233
7,182,102 B2 * 2/2007 Karcher 137/884
D544,580 S * 6/2007 Matsumoto et al. D23/233
D599,889 S * 9/2009 Oshima et al. D23/233

D606,168 S * 12/2009 Miyazoe D23/233
D621,477 S * 8/2010 Miyazoe et al. D23/233
D621,910 S * 8/2010 Miyazoe et al. D23/233
D621,911 S * 8/2010 Miyazoe et al. D23/233
7,849,881 B2 * 12/2010 Lee et al. 137/884
D653,307 S * 1/2012 Senba D23/233
D653,308 S * 1/2012 Senba D23/233
D665,874 S * 8/2012 Senba D23/233
D668,321 S * 10/2012 Senba D23/233

FOREIGN PATENT DOCUMENTS

JP D1367698 8/2009

OTHER PUBLICATIONS

U.S. Appl. No. 29/404,629; First Named Inventor: Yoshihiro Fukano;
Title: "Vacuum Supply Control Valve Manifold"; filed Oct. 24, 2011.

* cited by examiner

Primary Examiner — Cynthia Ramirez

(74) *Attorney, Agent, or Firm* — Holtz, Holtz, Goodman & Chick, PC

(57) **CLAIM**

The ornamental design for a vacuum supply control valve manifold, as shown.

DESCRIPTION

FIG. 1 is a front, top and right-side perspective view of a vacuum supply control valve manifold showing our new design;

FIG. 2 is a rear, bottom and left-side perspective view thereof;

FIG. 3 is a front view thereof;

FIG. 4 is a rear view thereof;

FIG. 5 is a top plan view thereof;

FIG. 6 is a bottom plan view thereof;

FIG. 7 is a left side view thereof; and,

FIG. 8 is a right side view thereof.

1 Claim, 8 Drawing Sheets

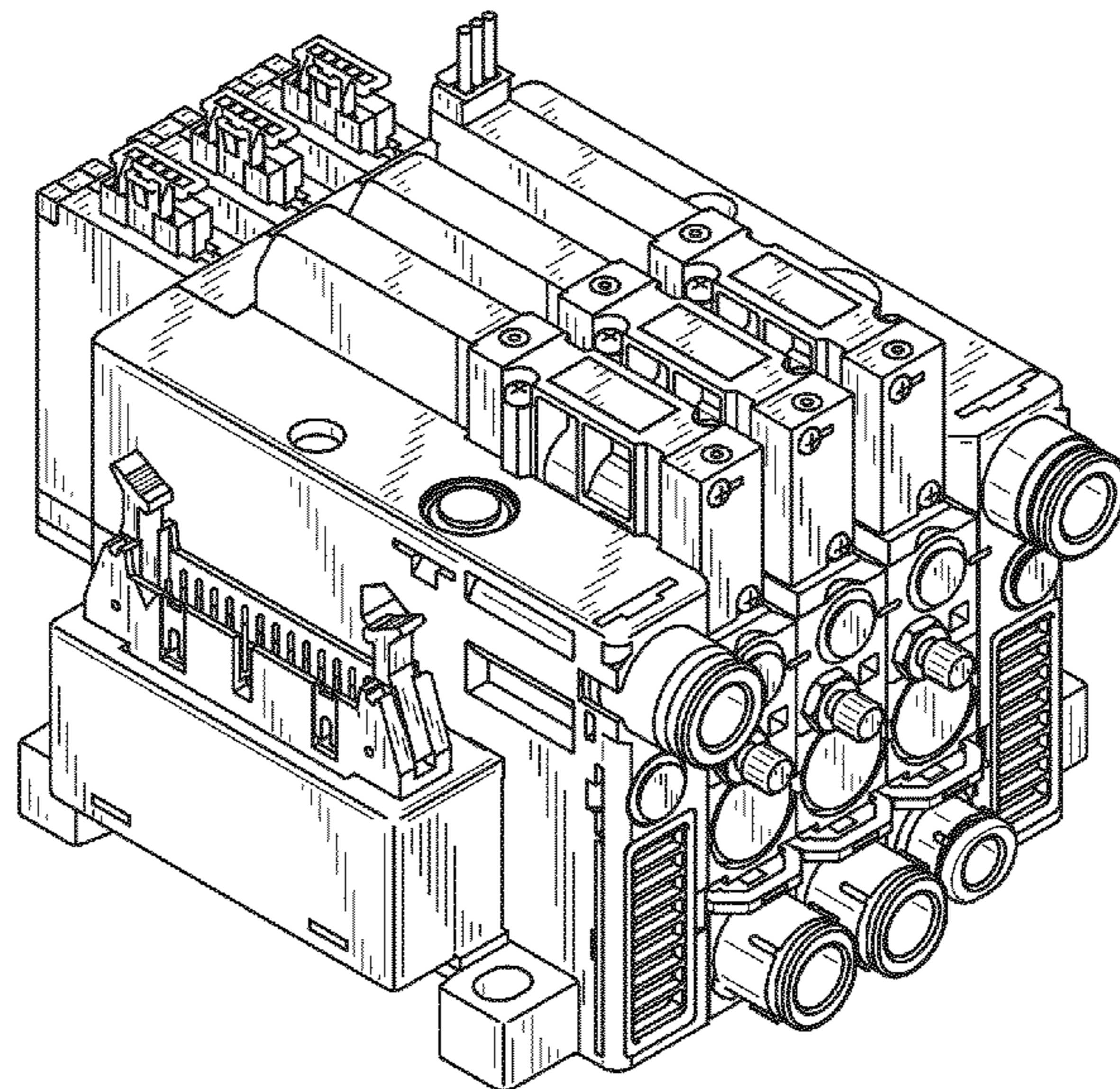

FIG. 1

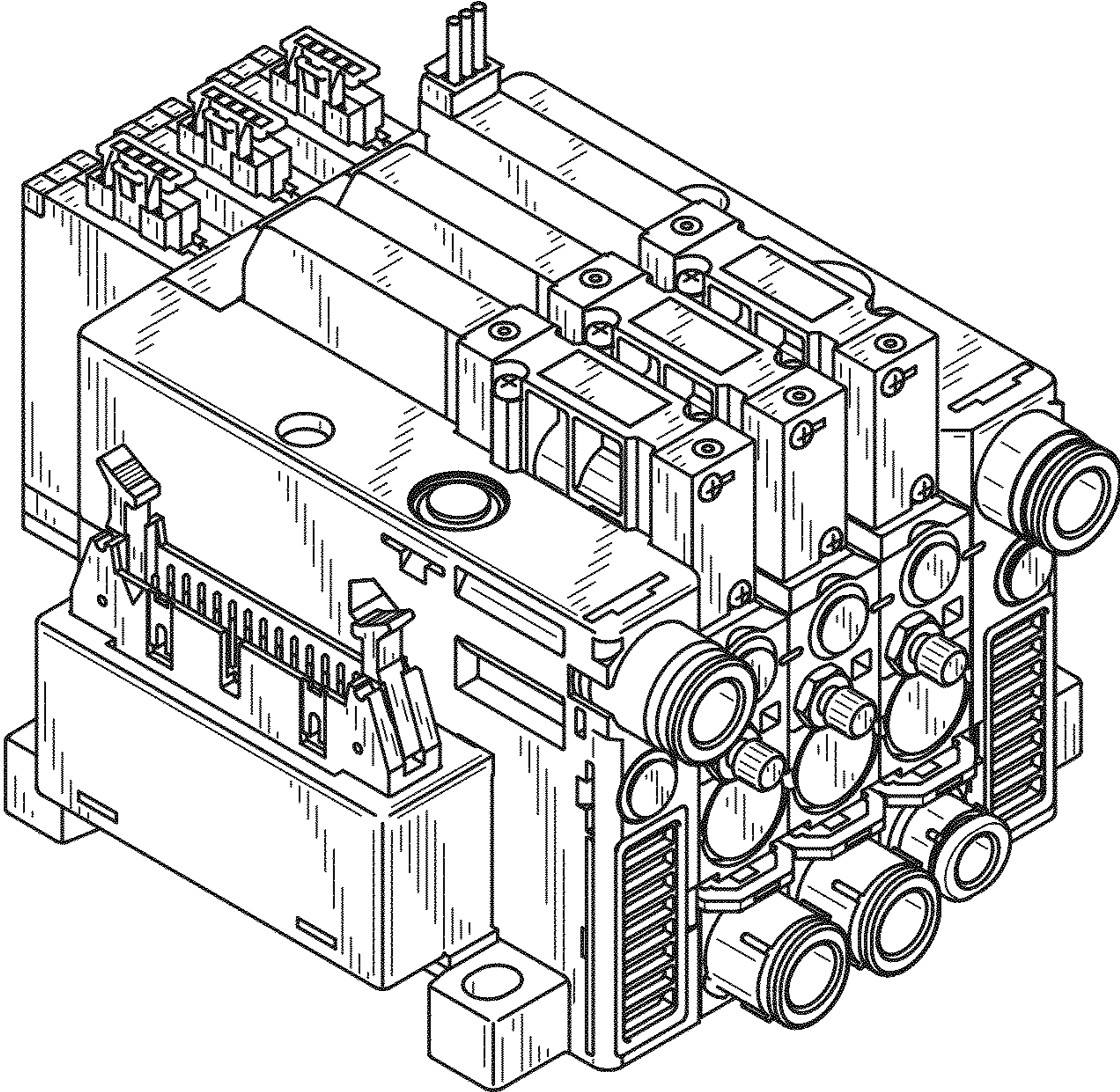

FIG. 2

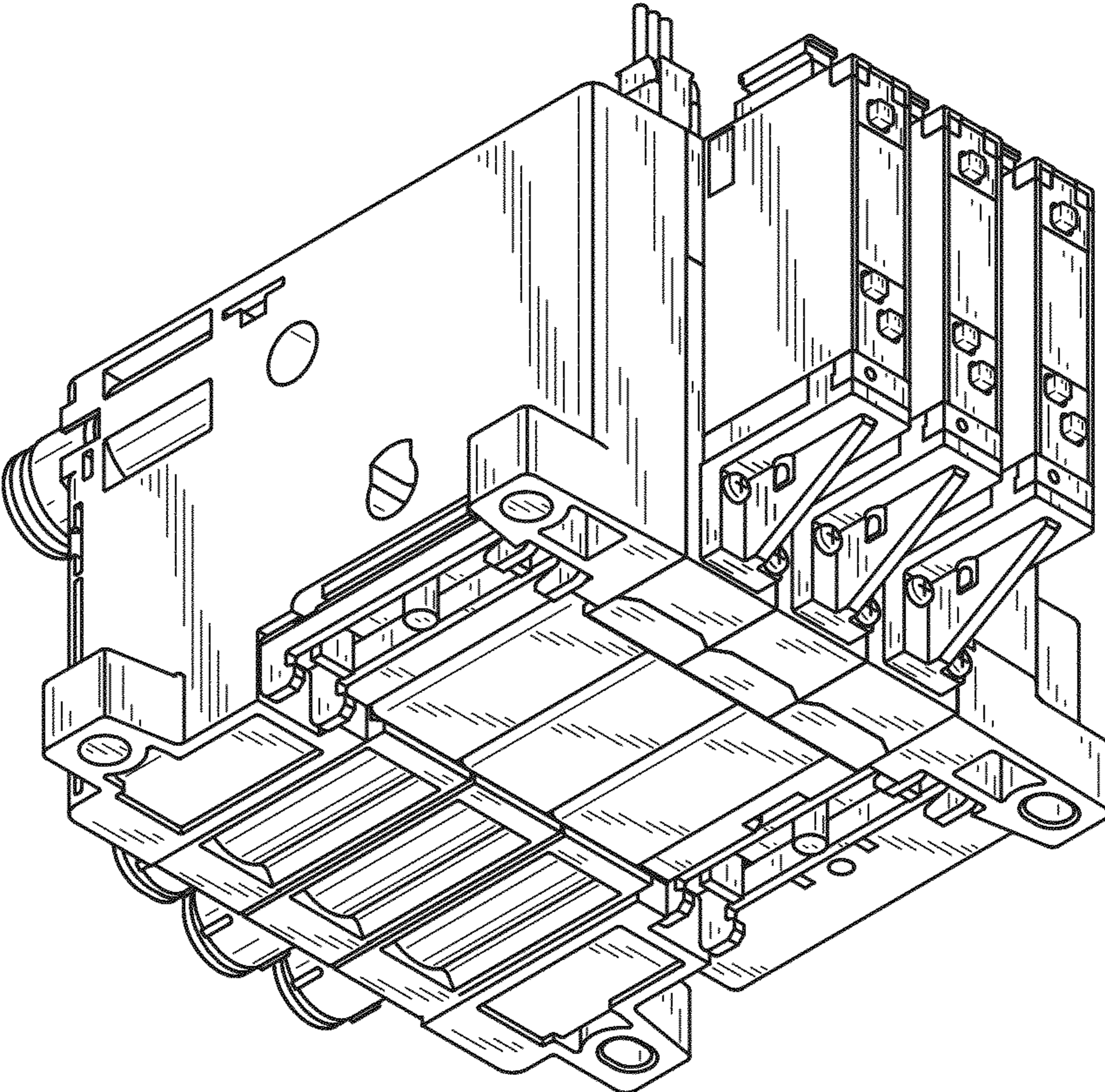

FIG. 3

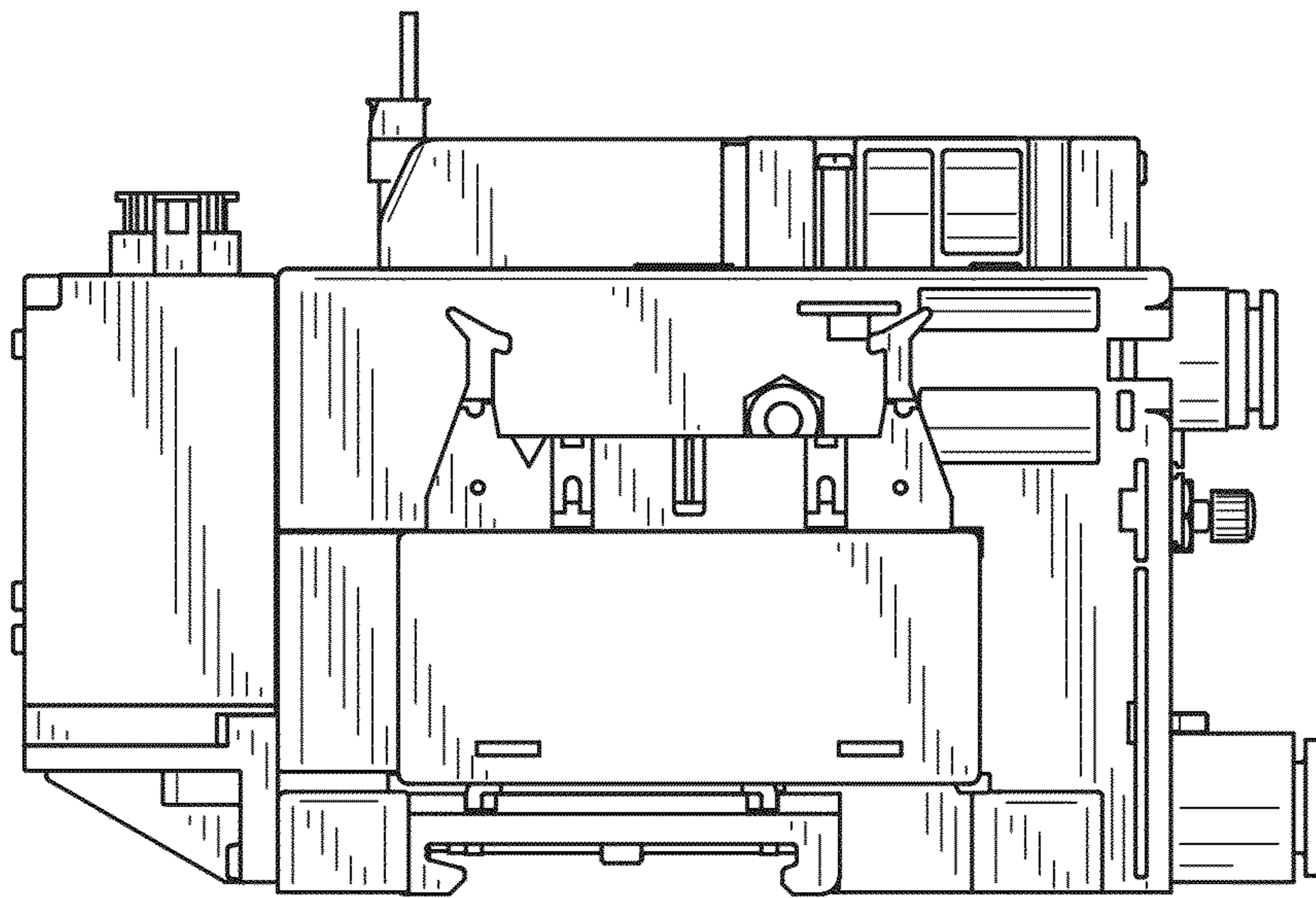

FIG. 4

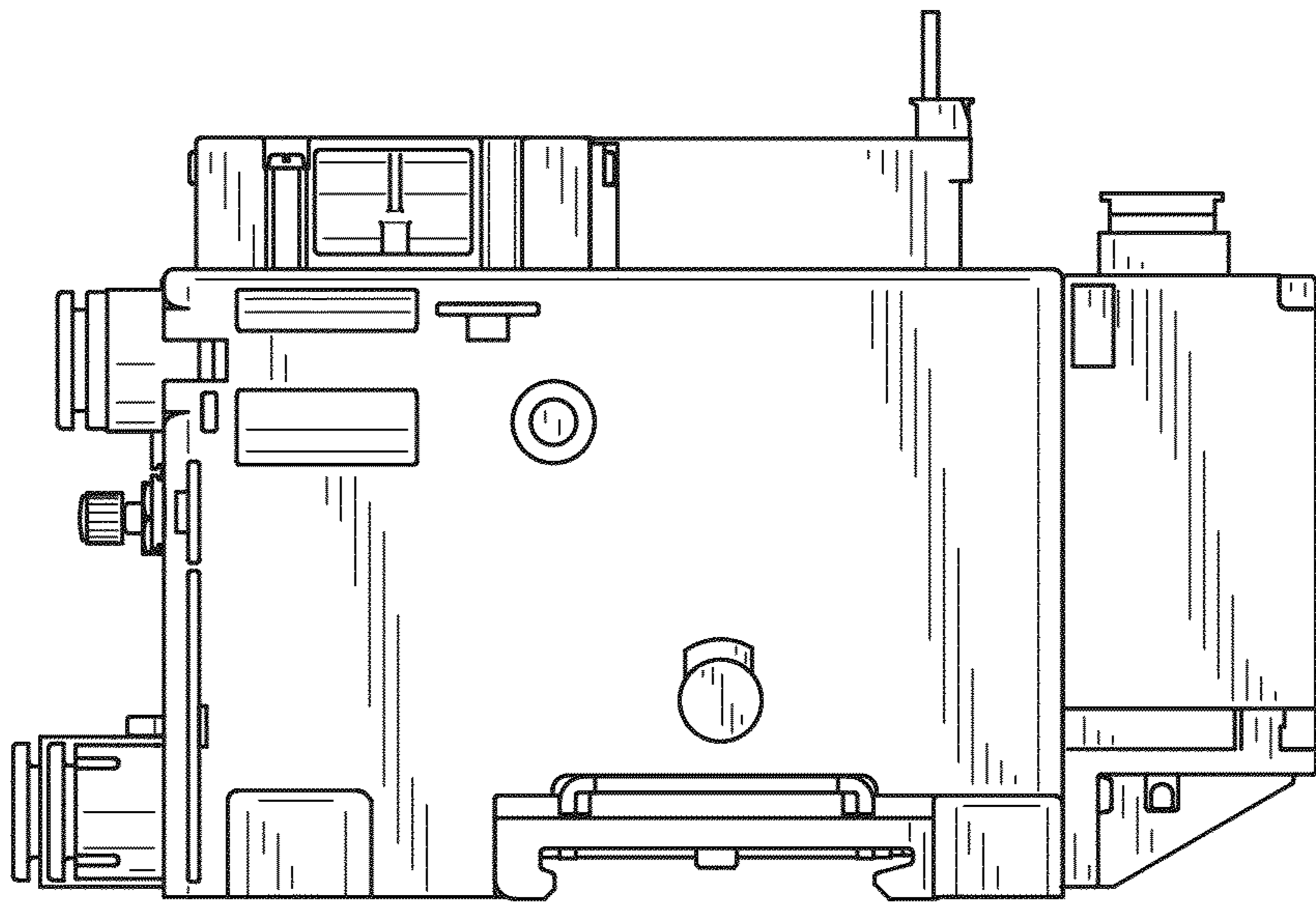

FIG. 5

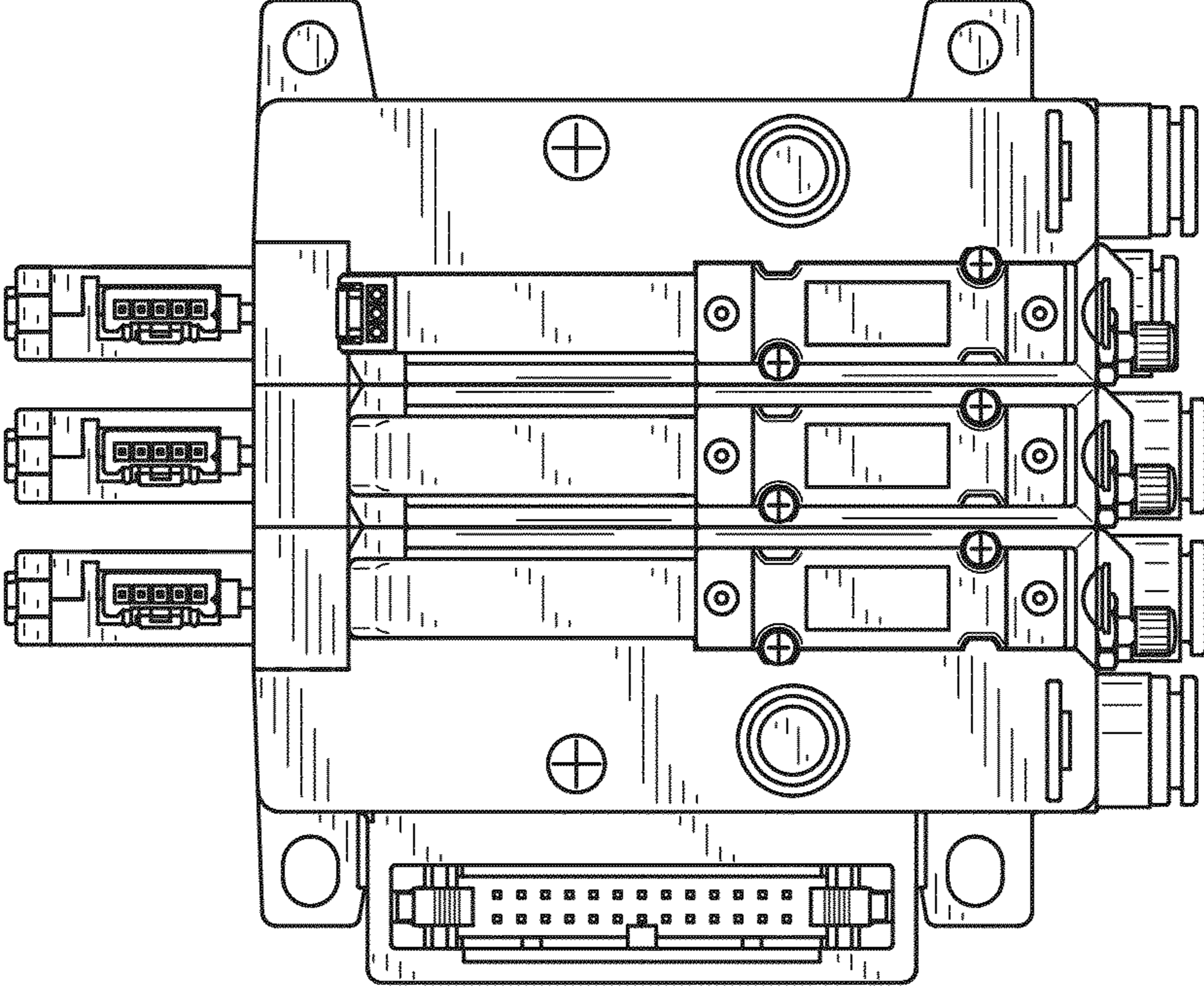

FIG. 6

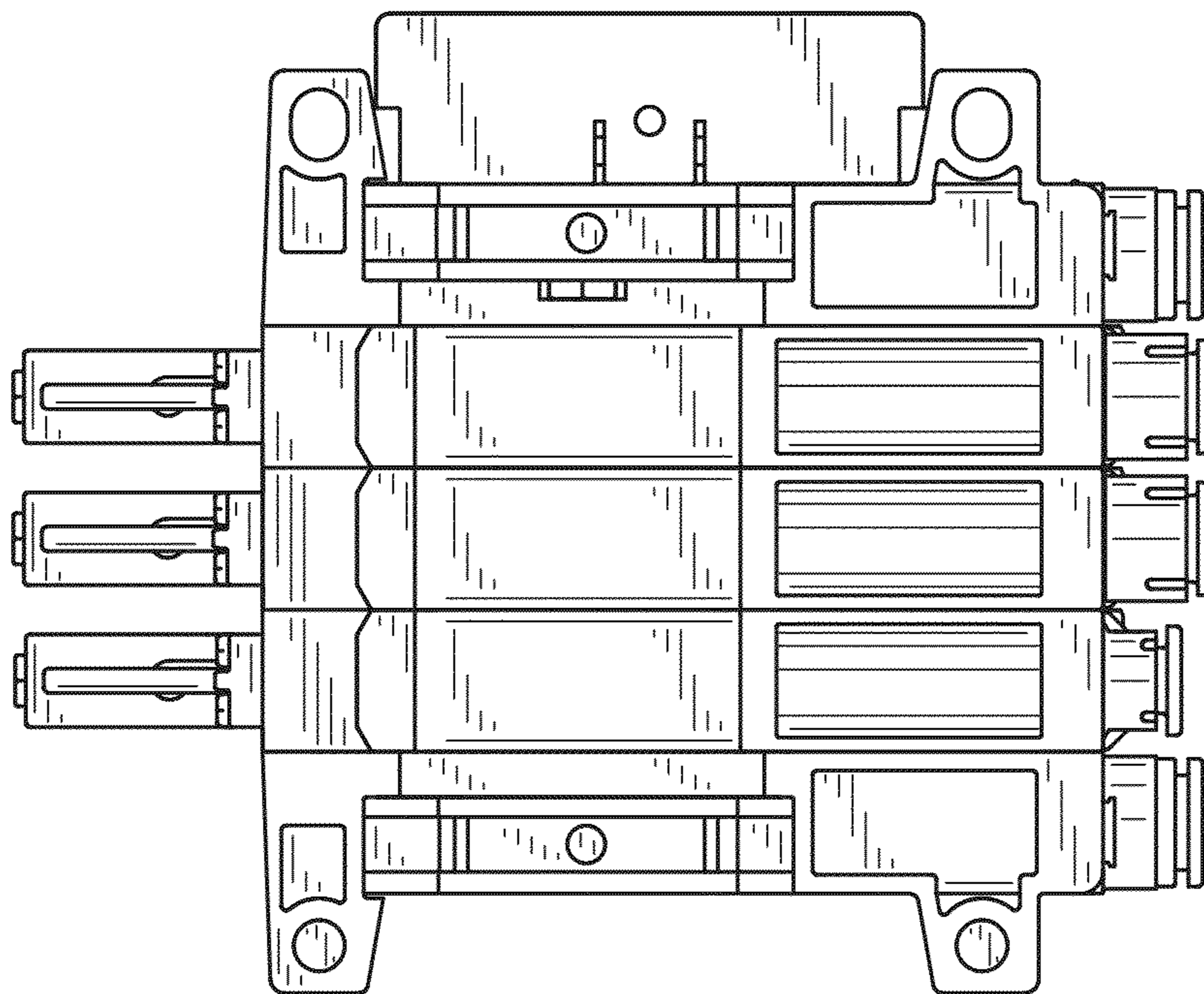

FIG. 7

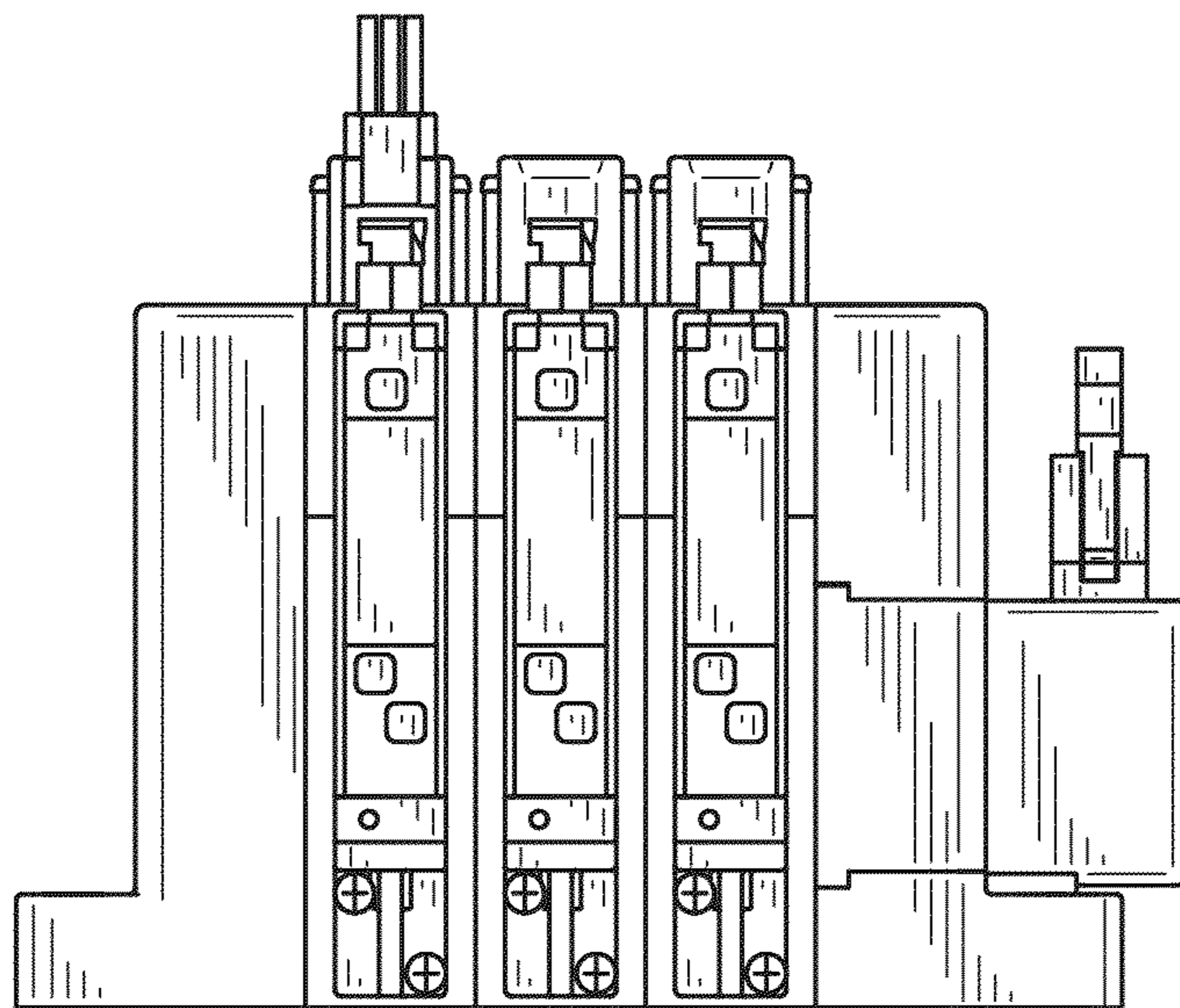

FIG. 8

