

US00D691701S

(12) **United States Design Patent**
Iranyi et al.

(10) **Patent No.:** **US D691,701 S**

(45) **Date of Patent:** **** Oct. 15, 2013**

(54) **VALVE ACTUATING DEVICE**

(75) Inventors: **Daniel Iranyi**, Steinhausen (CH); **Arno Lenzi**, Zürich (CH); **Tom Stäubli**, Zürich (CH)

(73) Assignee: **Siemens Aktiengesellschaft**, Munich (DE)

(**) Term: **14 Years**

(21) Appl. No.: **29/407,296**

(22) Filed: **Nov. 28, 2011**

(30) **Foreign Application Priority Data**

May 26, 2011 (EM) 001869454

(51) **LOC (9) Cl.** **23-01**

(52) **U.S. Cl.**
USPC **D23/233**

(58) **Field of Classification Search**
USPC D23/233–237, 244–249, 255–269,
D23/310; D15/5; 92/62–64, 80–82, 170;
192/12 R
See application file for complete search history.

(56) **References Cited**

U.S. PATENT DOCUMENTS

D191,294 S * 9/1961 Charnota D23/246
D236,980 S * 9/1975 Callahan et al. D23/233

D309,175 S * 7/1990 Hastings et al. D23/245
D317,494 S * 6/1991 Miyake et al. D23/235
D317,815 S * 6/1991 Jeromson et al. D23/233
D361,627 S * 8/1995 Garrard et al. D23/235
D410,525 S * 6/1999 Uehara et al. D23/235
D603,015 S * 10/2009 Matsumura D23/233
D603,016 S * 10/2009 Matsumura D23/233
D620,553 S * 7/2010 Li et al. D23/233
D629,871 S * 12/2010 Marinoni et al. D23/249
D629,872 S * 12/2010 Marinoni et al. D23/249
D633,986 S * 3/2011 Ito et al. D23/233
D637,270 S * 5/2011 Nicolia et al. D23/235
D681,782 S * 5/2013 Bohm et al. D23/233

* cited by examiner

Primary Examiner — Cynthia Ramirez

(74) *Attorney, Agent, or Firm* — Laurence A. Greenberg;
Werner H. Stemer; Ralph E. Locher

(57) **CLAIM**

The ornamental design for a valve actuating device, as shown and described.

DESCRIPTION

FIG. 1 is a perspective view of the valve actuating device showing our new design;
FIG. 2 is a front view thereof;
FIG. 3 is a bottom view thereof;
FIG. 4 is a right side, elevation view thereof;
FIG. 5 is a top plan view thereof;
FIG. 6 is a rear view thereof; and,
FIG. 7 is a left side, elevation view thereof.

1 Claim, 4 Drawing Sheets

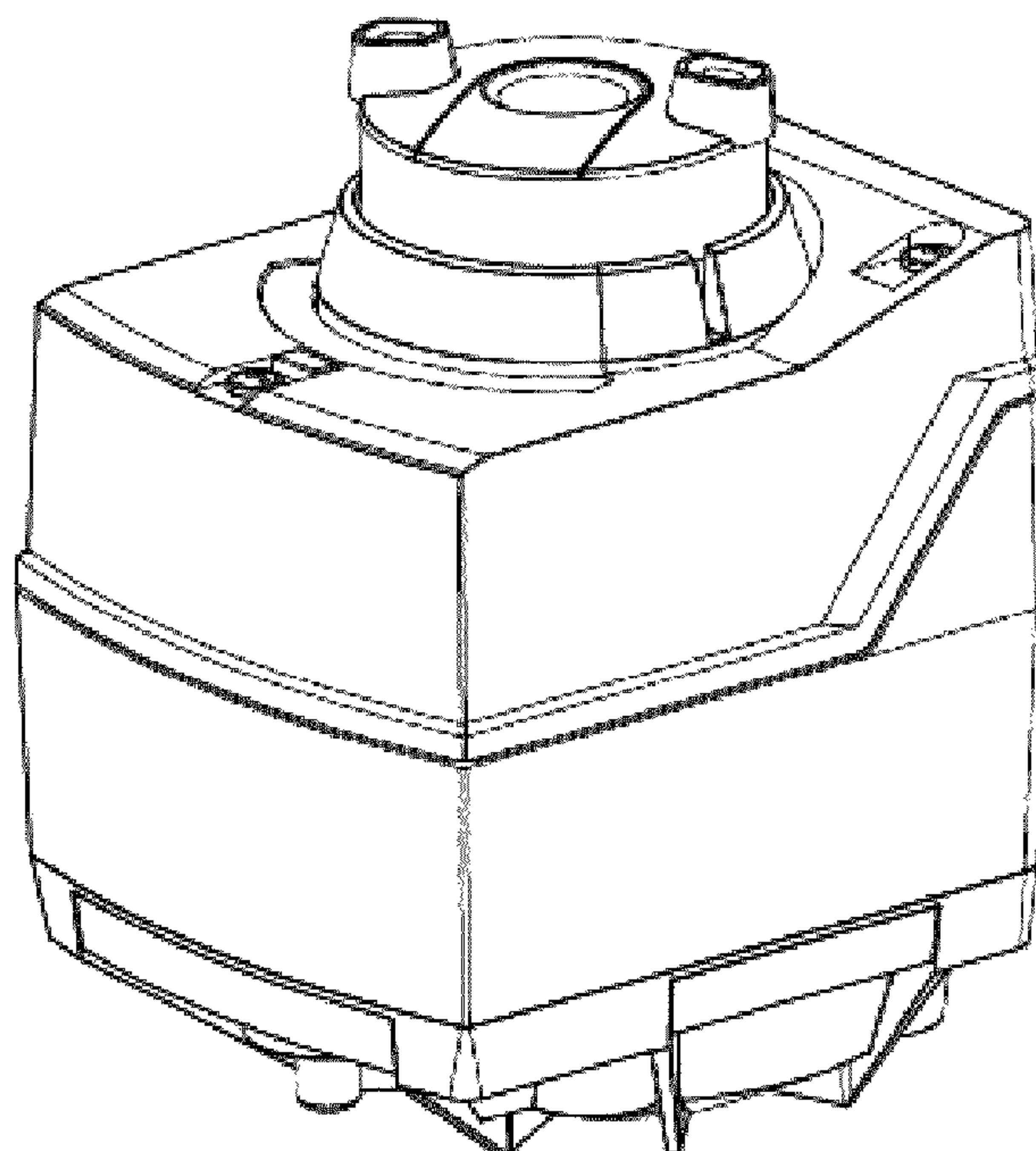

FIG. 1

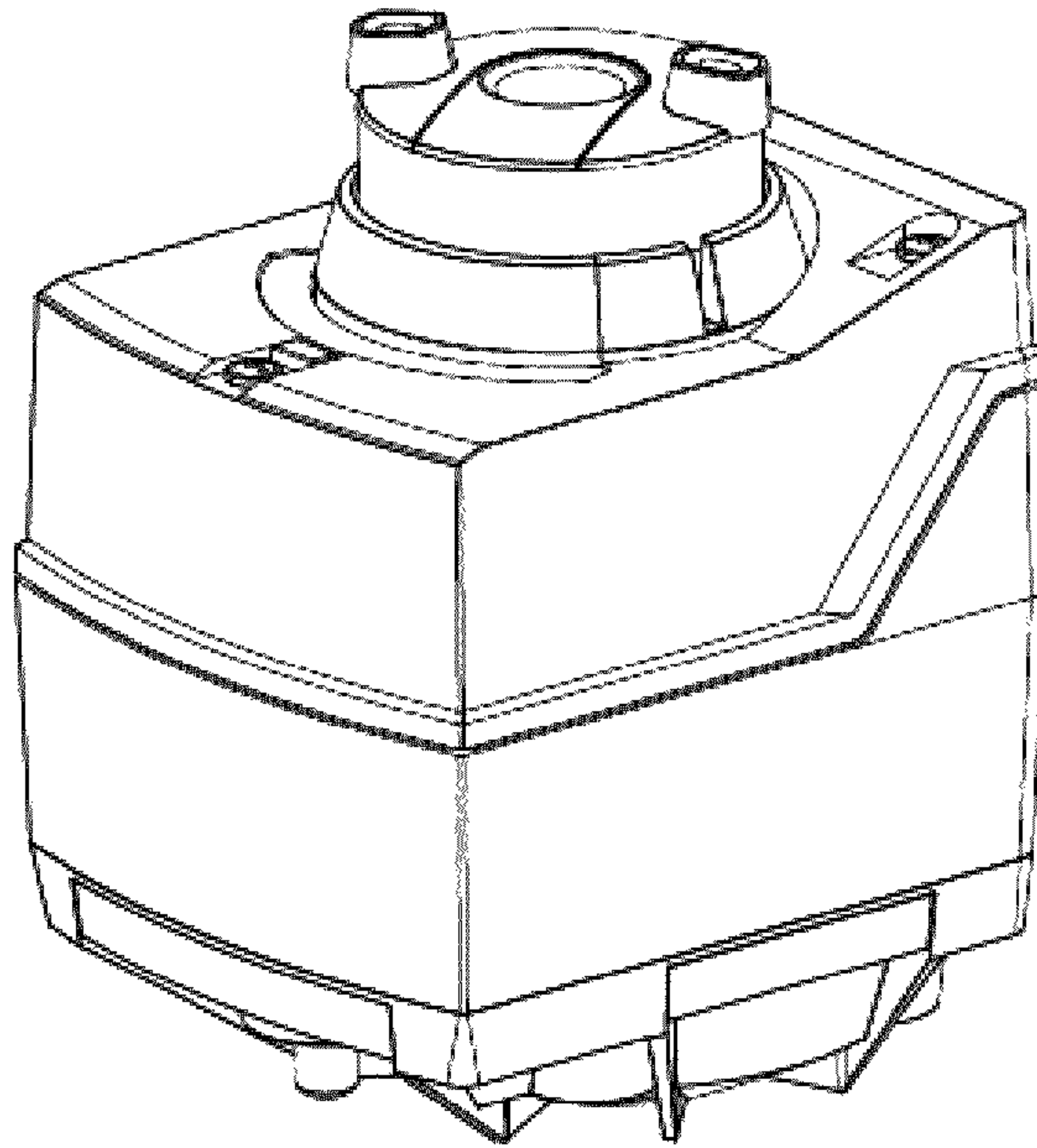

FIG. 2

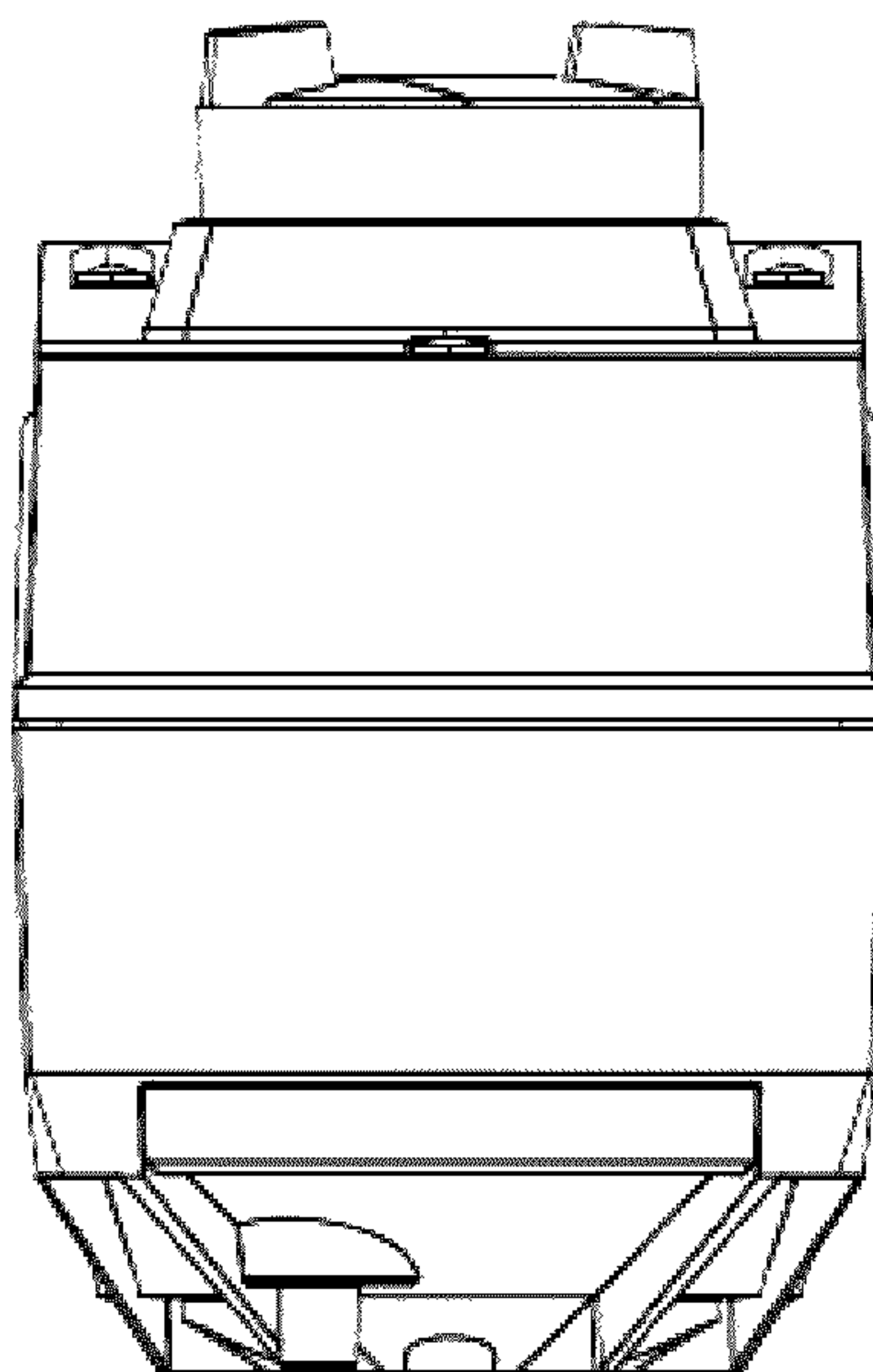

FIG. 3

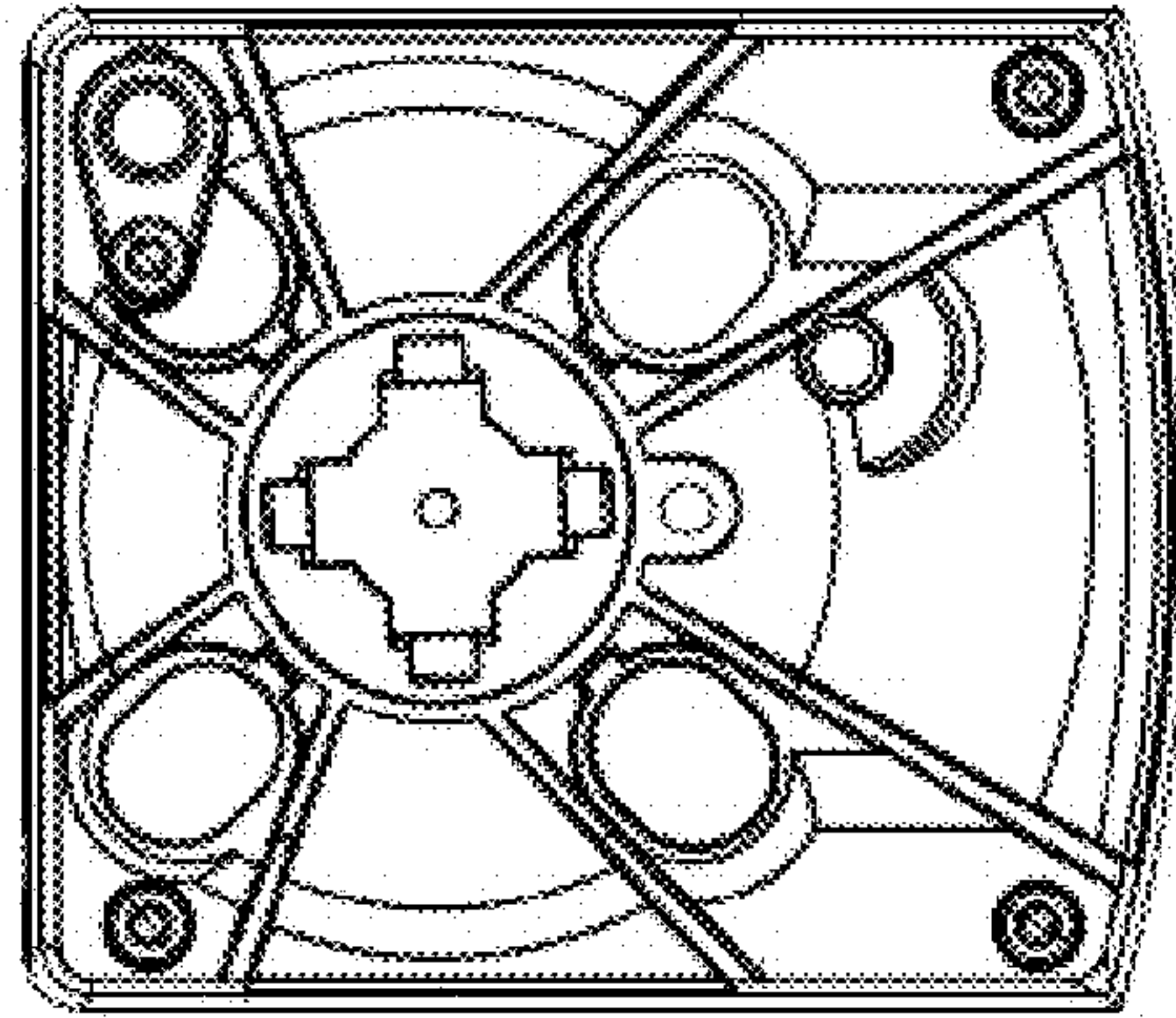

FIG. 4

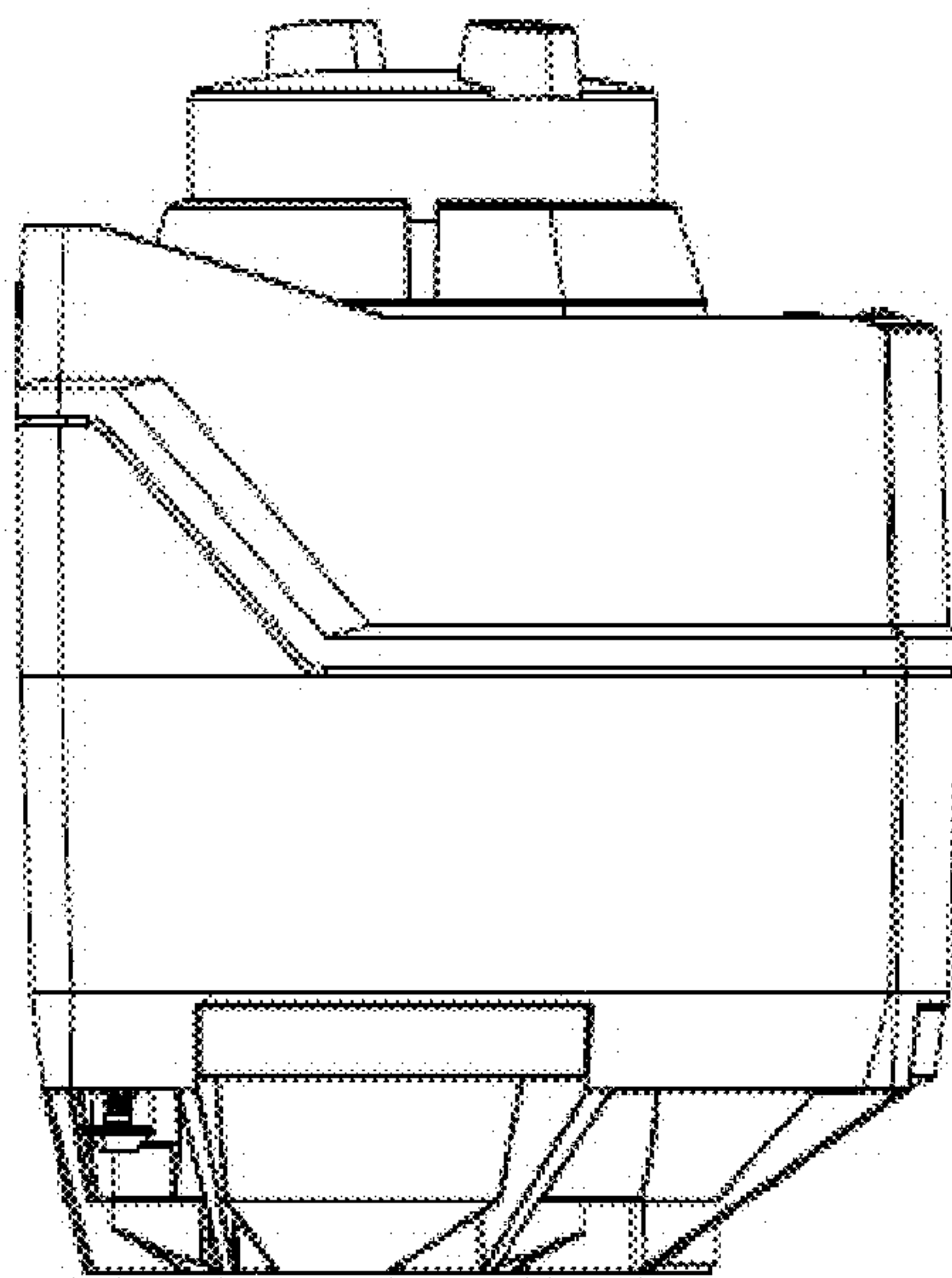

FIG. 5

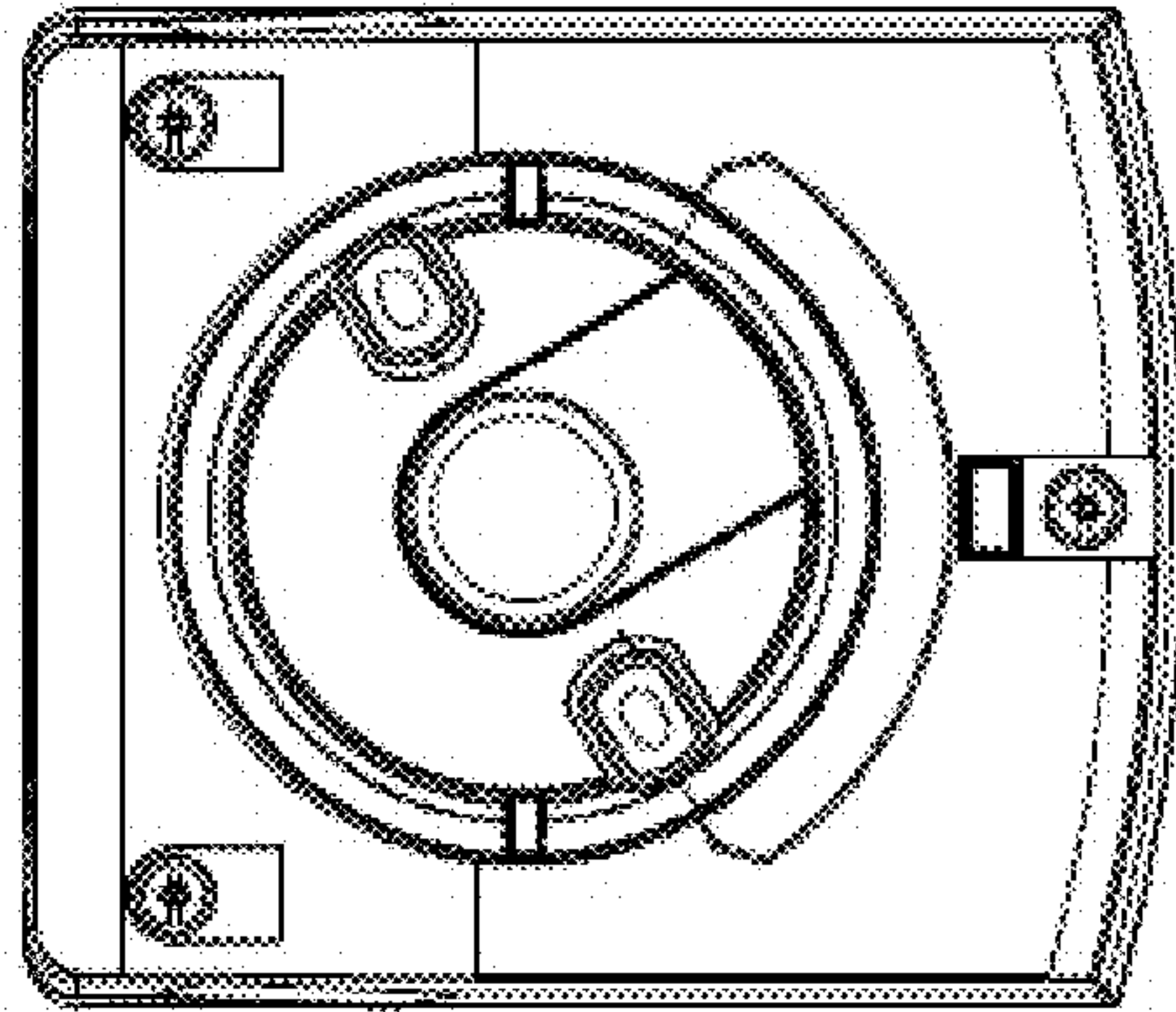

FIG. 6

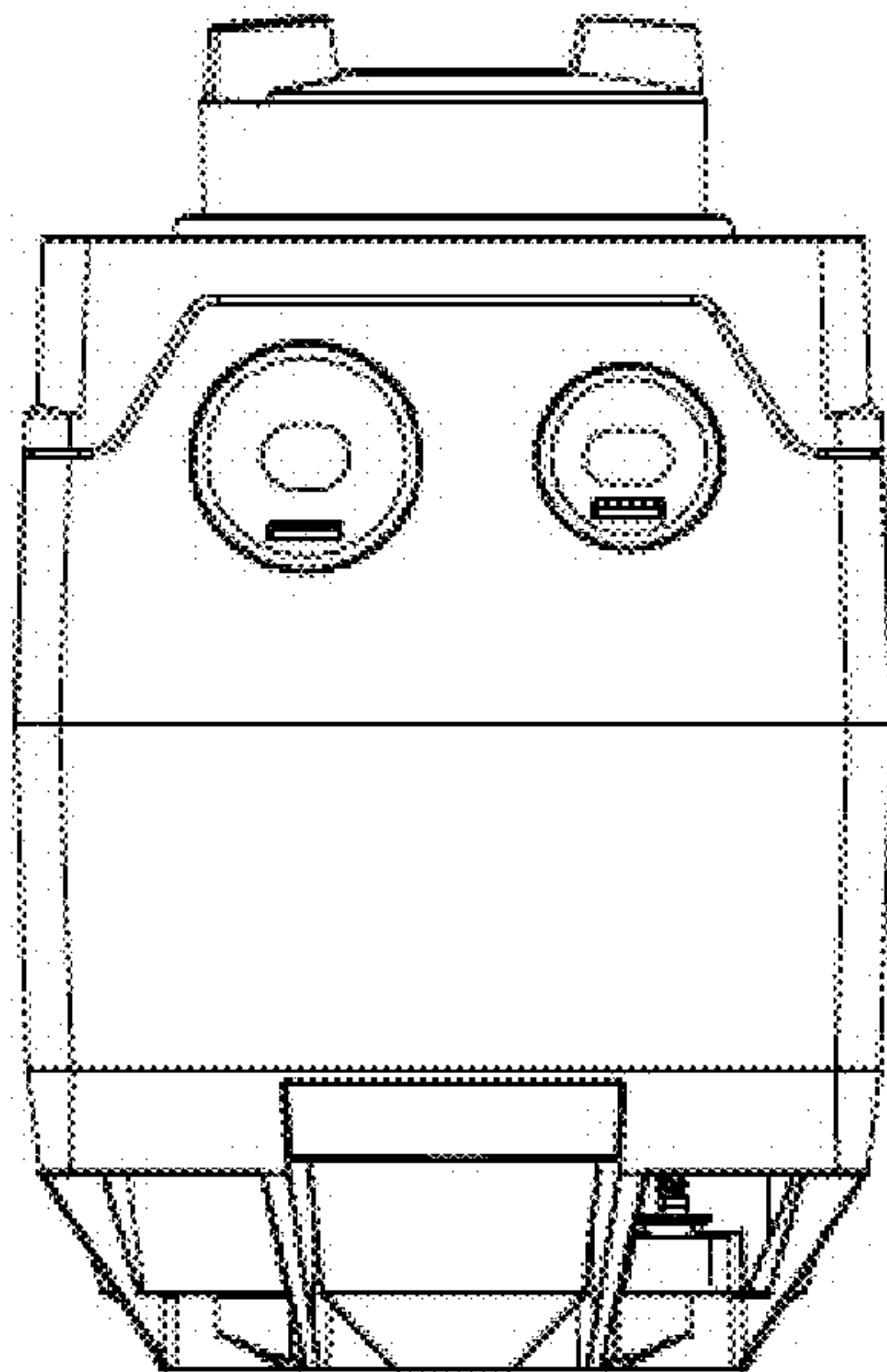

FIG. 7

