



US00D691550S

(12) **United States Design Patent**
Moeller

(10) **Patent No.:** **US D691,550 S**
(45) **Date of Patent:** **** Oct. 15, 2013**

- (54) **CROSSBAR FOR A VEHICLE ROOFTOP CARRIER RACK**
- (75) Inventor: **Mattias Roger Moeller**, Bankeryd (SE)
- (73) Assignee: **Thule Sweden AB**, Hillerstorp (SE)
- (**) Term: **14 Years**
- (21) Appl. No.: **29/393,876**
- (22) Filed: **Jun. 10, 2011**
- (51) **LOC (9) Cl.** **12-16**
- (52) **U.S. Cl.**
USPC **D12/412**
- (58) **Field of Classification Search**
USPC D12/412, 406, 414, 414.1; 293/37.1, 3, 293/100; 224/309-310, 315-316, 323-329, 224/400; D6/552; D3/304-306; 280/760-762, 848, 727, 769
See application file for complete search history.

(56) **References Cited**

U.S. PATENT DOCUMENTS

D172,817 S *	8/1954	Binding	D12/412
D332,243 S *	1/1993	Collins	D12/413
5,845,828 A *	12/1998	Settelmayer	224/321
D415,096 S *	10/1999	Englander et al.	D12/406
6,561,396 B2	5/2003	Ketterhagen		

(Continued)

Primary Examiner — Katrina A Betton

(74) *Attorney, Agent, or Firm* — Novak Druce Connolly Bove & Quigg

(57) **CLAIM**

I claim the ornamental design for a crossbar for a vehicle rooftop carrier rack, as shown and described.

DESCRIPTION

FIG. 1 is a perspective view of a crossbar for a vehicle rooftop carrier rack;

FIG. 2 is a top perspective view thereof;
 FIG. 3 is a bottom perspective view thereof;
 FIG. 4 is a front elevational view thereof;
 FIG. 5 is a detailed front view of the right end thereof;
 FIG. 6 is rear elevational view thereof;
 FIG. 7 is a detailed rear view of the left end thereof, (the right end being a mirror image of the left end);
 FIG. 8 is a top plan view thereof;
 FIG. 9 is a detailed top view of the right end thereof, (the right end being a mirror image of the left end);
 FIG. 10 is a bottom plan view thereof;
 FIG. 11 is a detailed bottom view of the left end thereof, (the right end being a mirror image of the left end);
 FIG. 12 is a left side elevational view thereof, (the right side being a mirror image thereof);
 FIG. 13 is an upper perspective view of the left end thereof;
 FIG. 14 is an upper perspective view of the right end thereof;
 FIG. 15 is a lower perspective view of the left end thereof;
 FIG. 16 is a lower perspective view of the right end thereof;
 and,
 FIG. 17 is a cross sectional view of the article at a vertical line bisecting the design in FIG. 4.
 The left and right sides of the design are mirror images of one another. Therefore, the right side has not been shown. The right and left ends of the design are mirror images of one another. The cross-sectional view of FIG. 17 has been included to show the contour of the surface of the design; the interior structure does not form a part of the claimed design. The broken lines in FIG. 1 are included for the purpose of illustrating environment, and do not form a part of the claimed design. The broken lines in FIGS. 3, 10, 11, 14, 15 and 16 are included for the purpose of indicating unclaimed portions of the crossbar for a vehicle rooftop carrier rack.

1 Claim, 13 Drawing Sheets

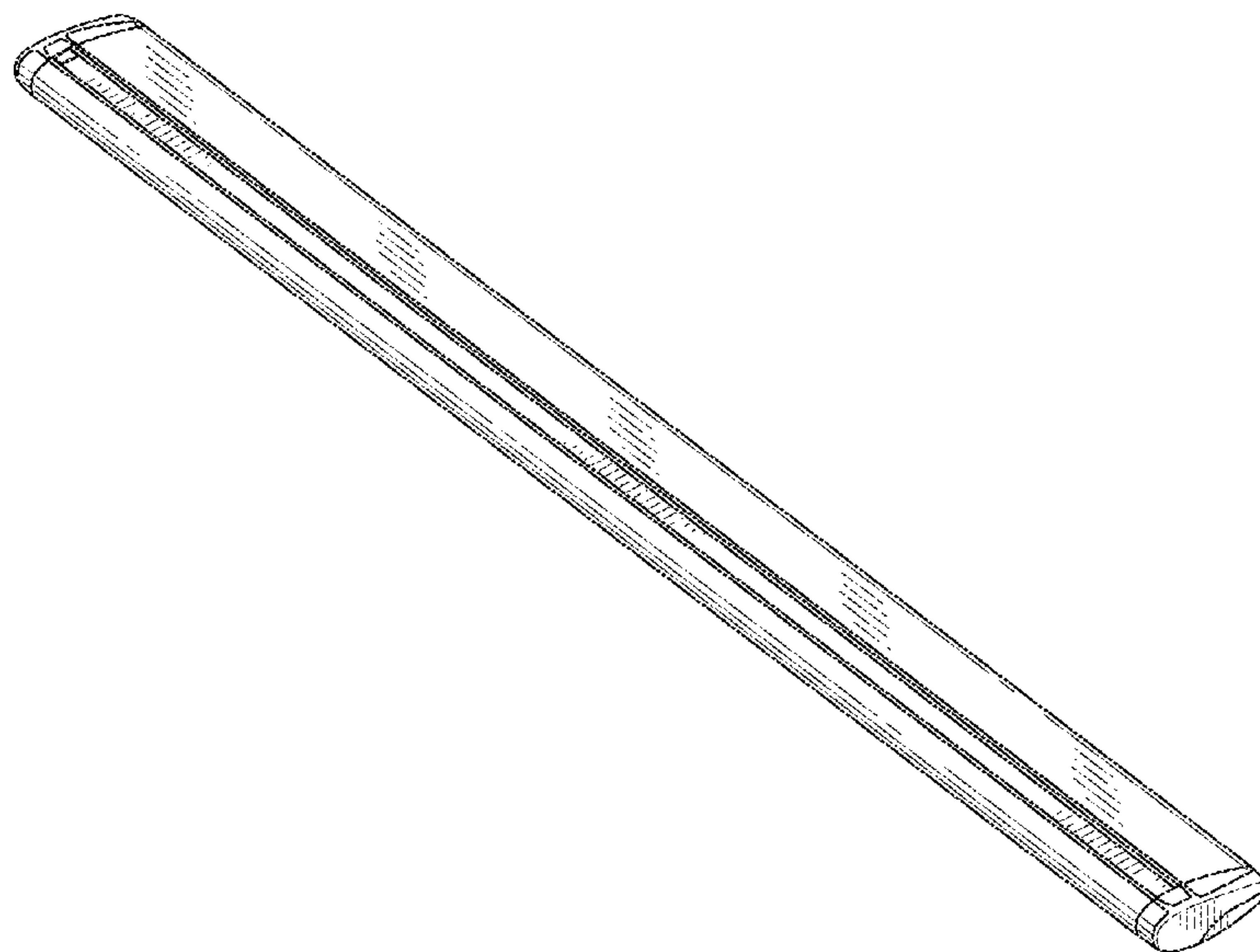

(56)

References Cited

U.S. PATENT DOCUMENTS

D535,599 S *	1/2007	Woods	D12/181	7,810,686 B2	10/2010	Ilgenfritz	
D555,573 S *	11/2007	Kemery et al.	D12/412	D642,112 S *	7/2011	Farber	D12/414
7,328,829 B2 *	2/2008	Arad et al.	227/176.1	D642,113 S *	7/2011	Farber	D12/414
D566,034 S *	4/2008	Davis et al.	D12/408	7,971,847 B1 *	7/2011	Hartzell et al.	248/688
				2009/0120982 A1	5/2009	Sautter et al.	
				2010/0043186 A1	2/2010	Lesley	

* cited by examiner

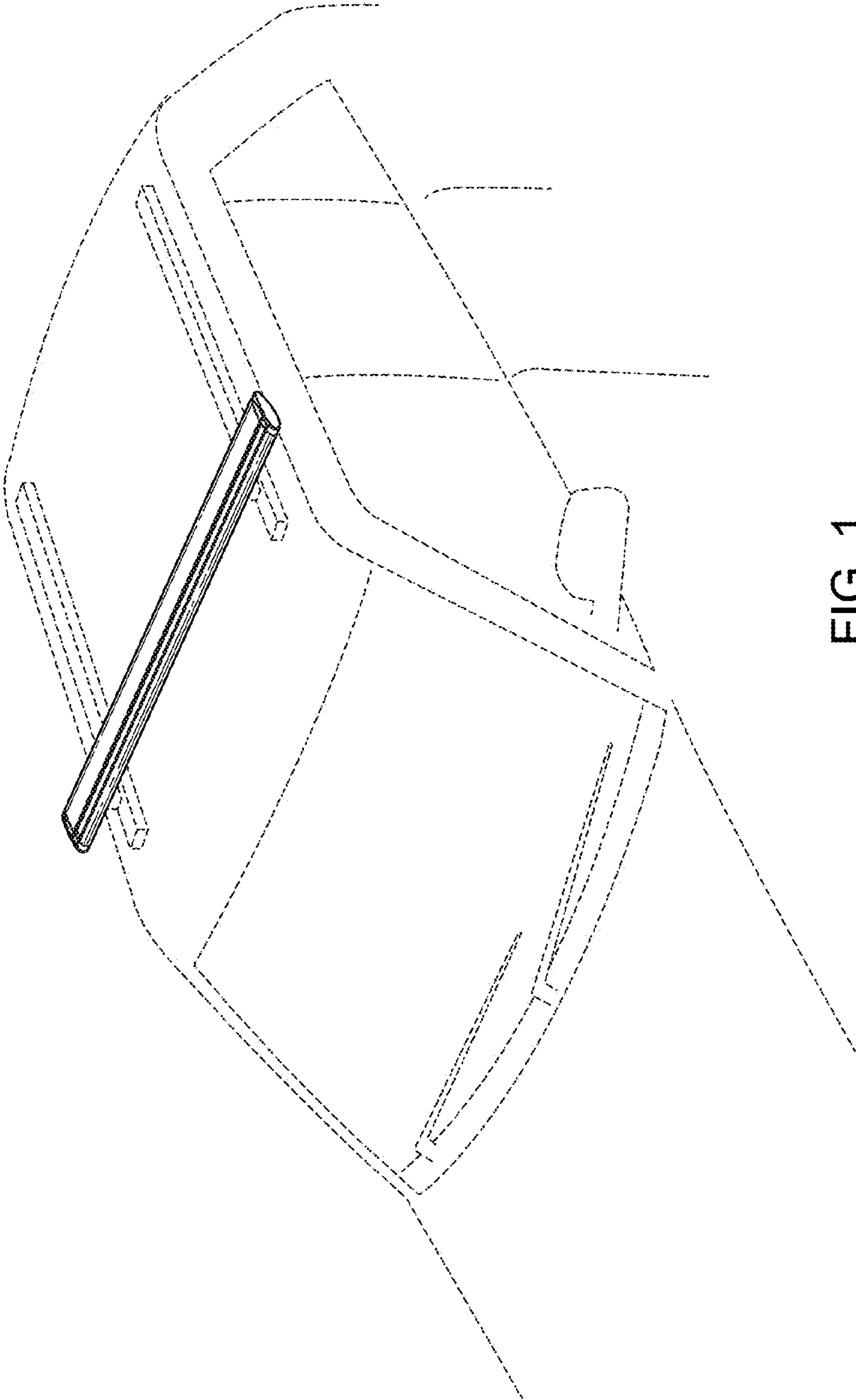

FIG. 1

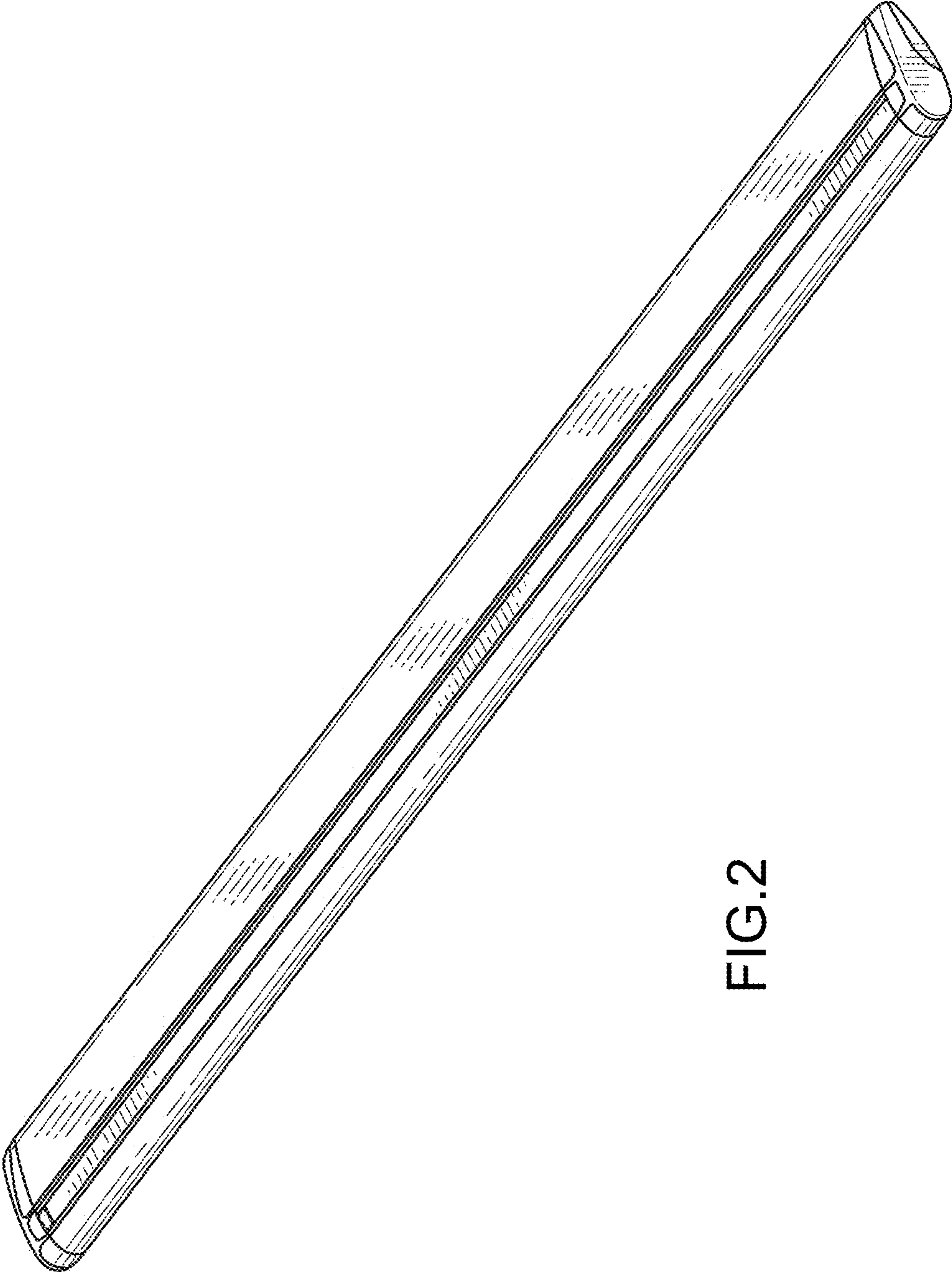

FIG.2

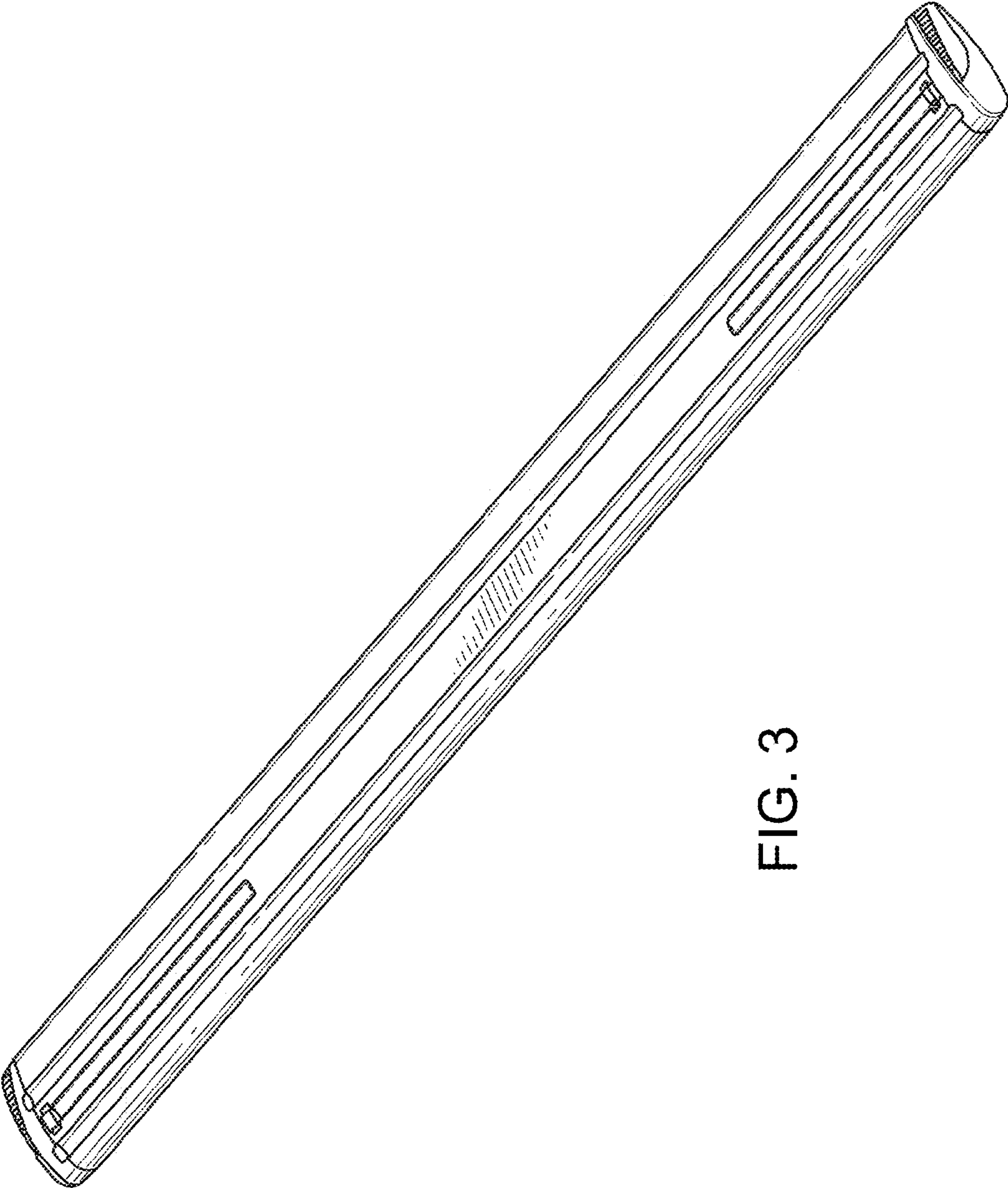

FIG. 3

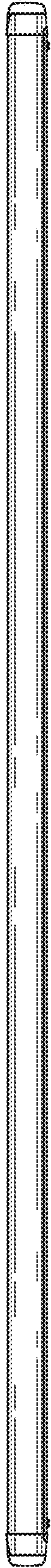

FIG. 4

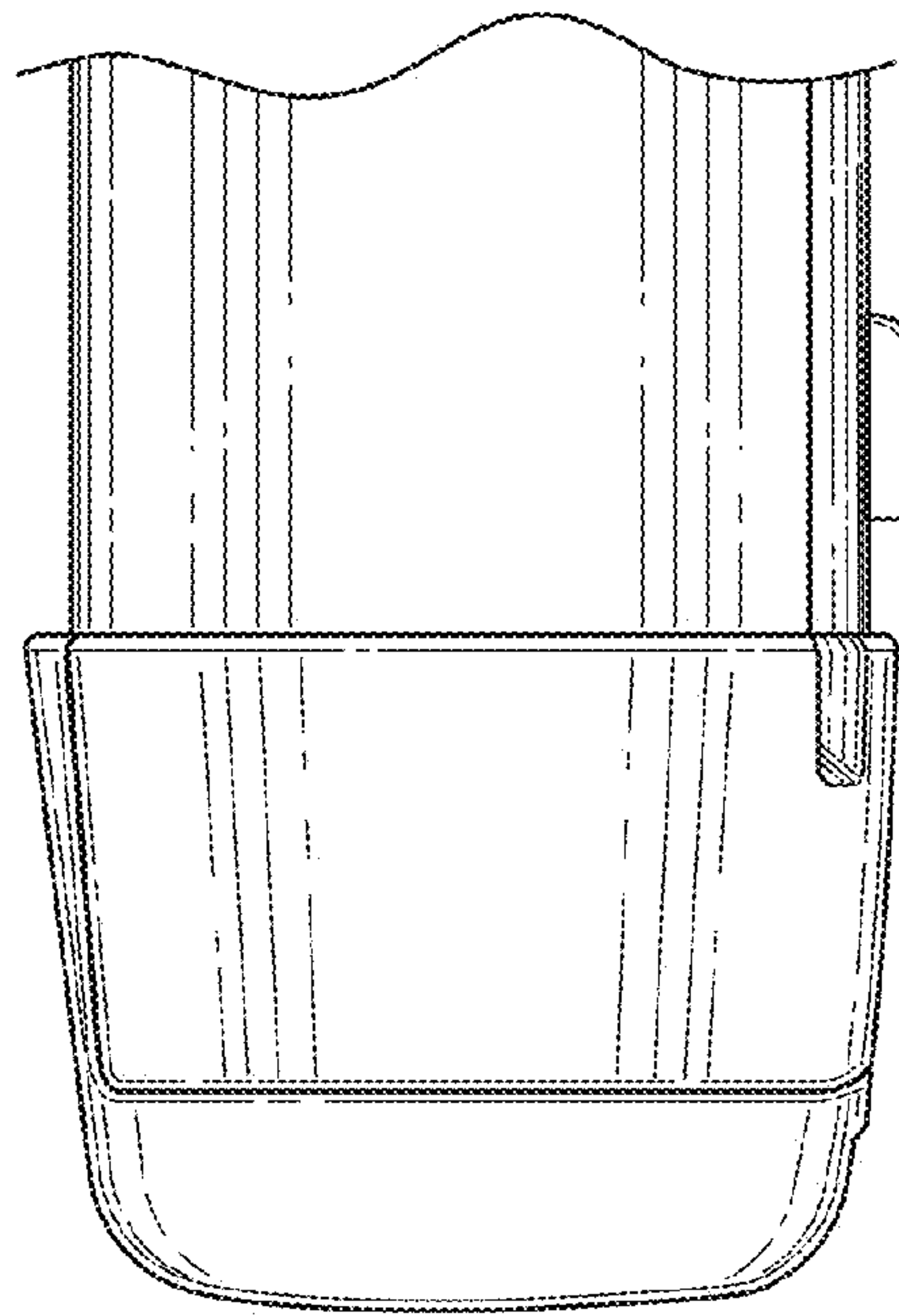

FIG. 5

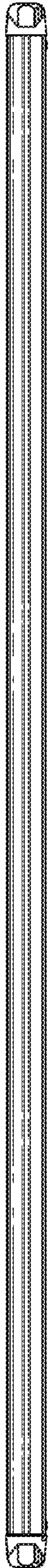

FIG. 6

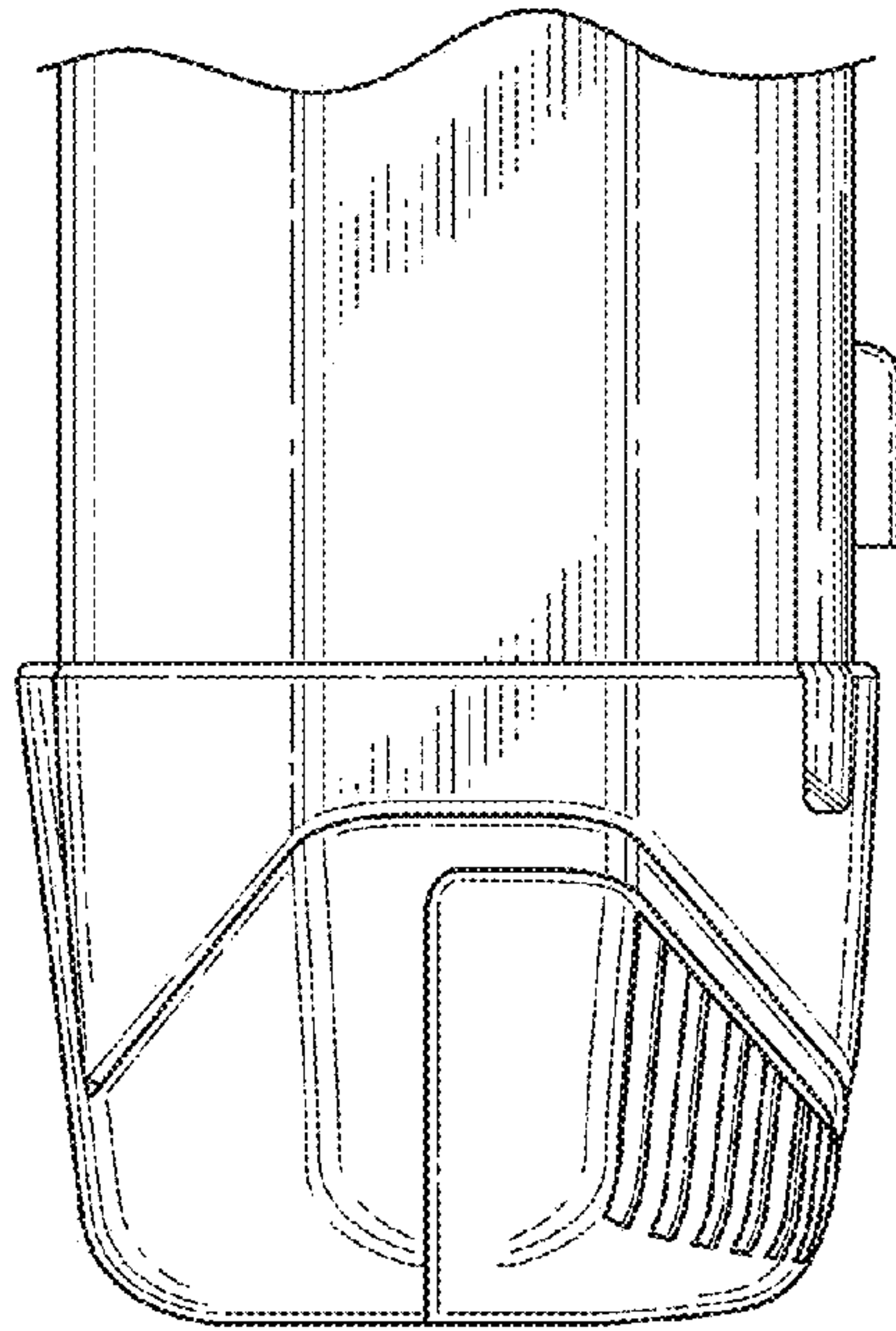

FIG. 7

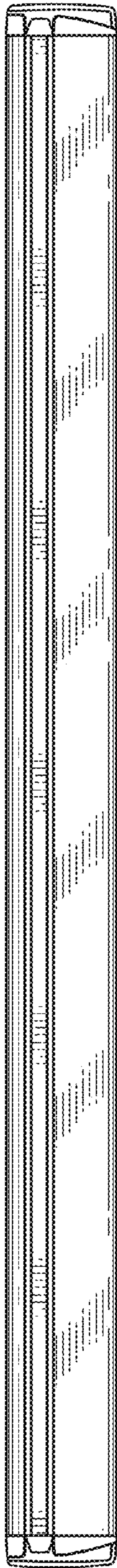

FIG. 8

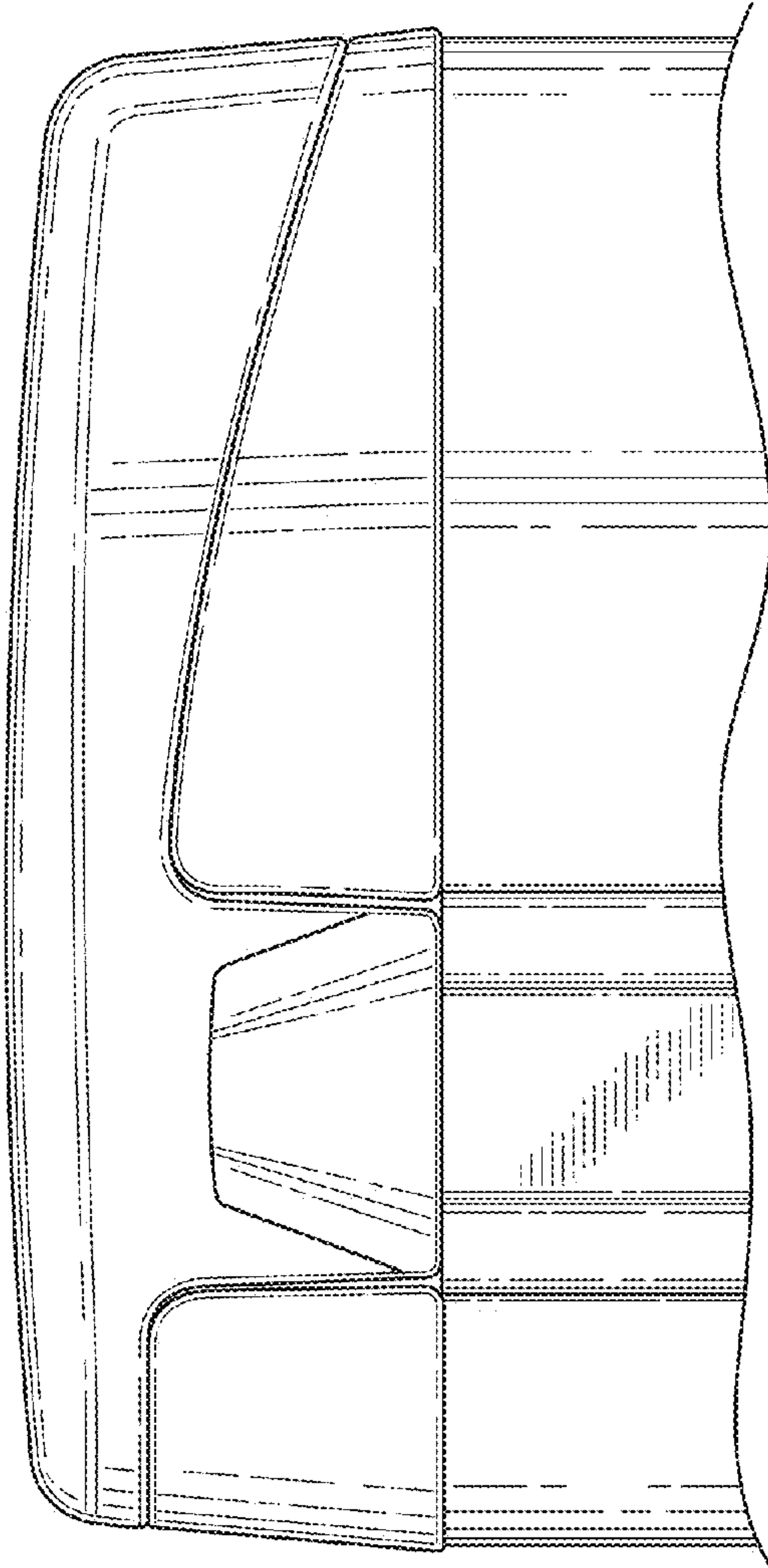

FIG. 9

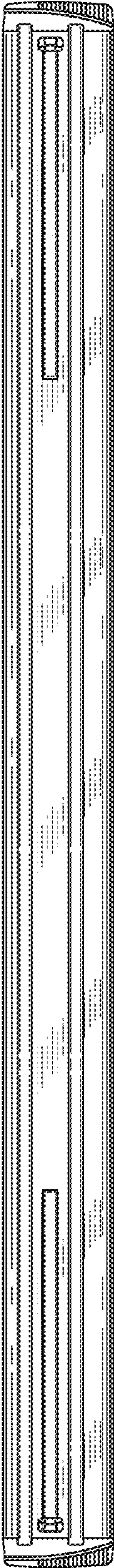

FIG. 10

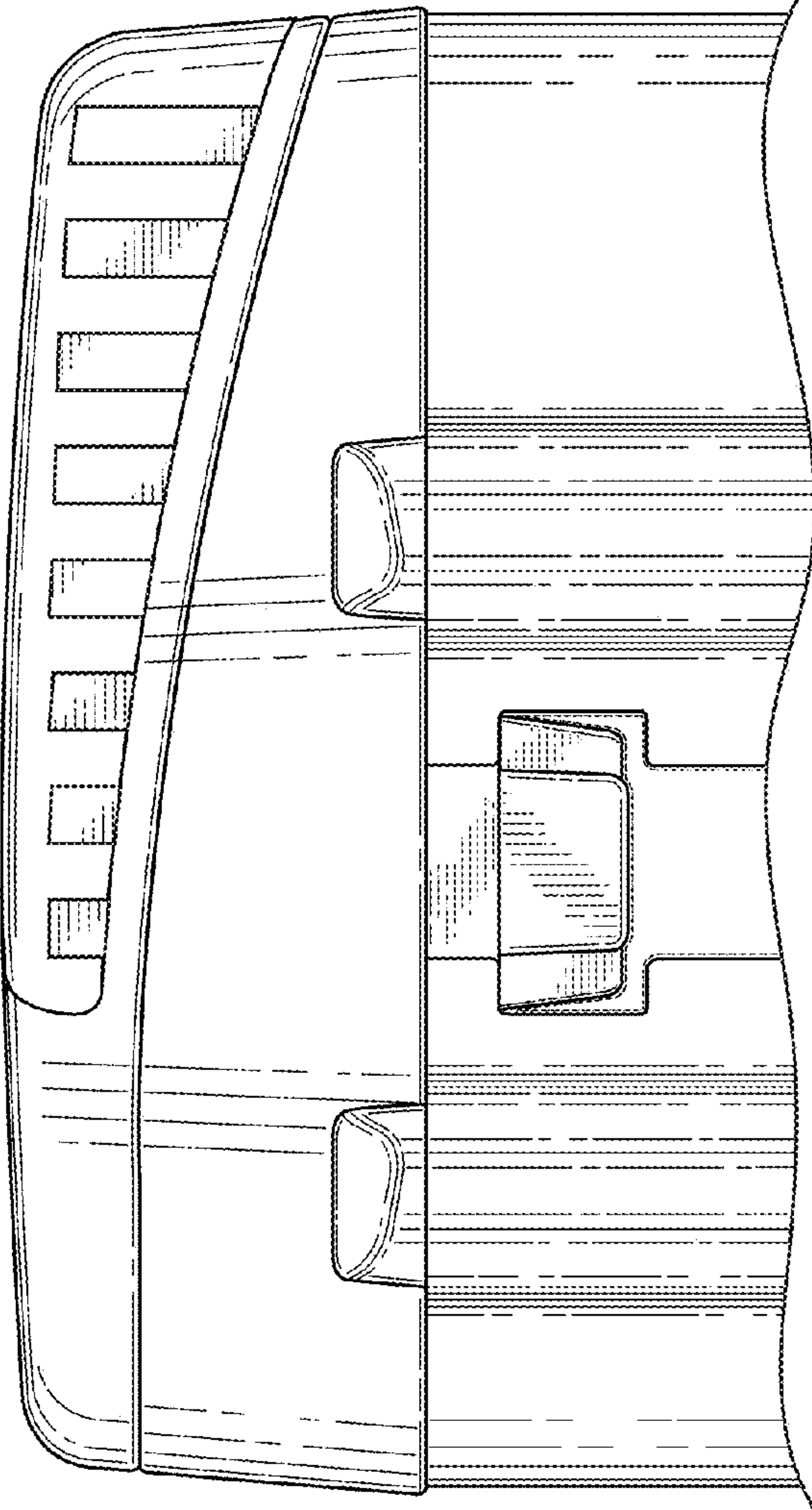

FIG. 11

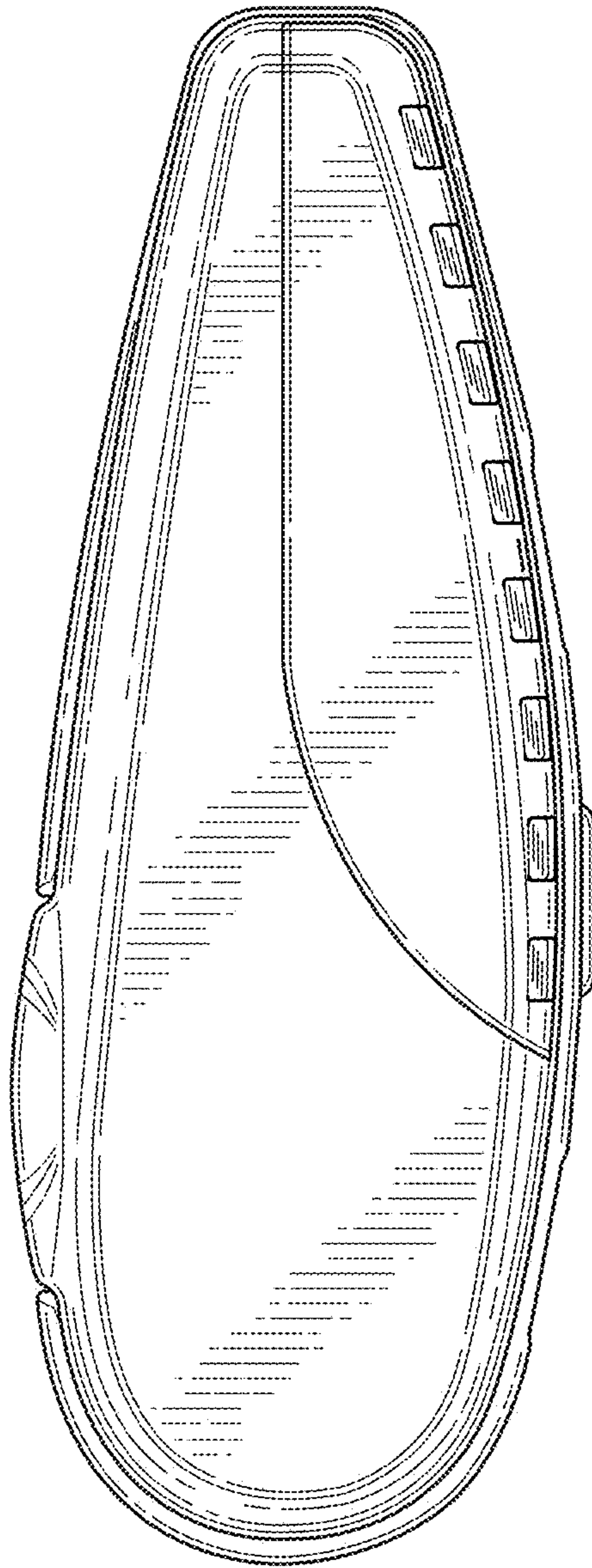

FIG. 12

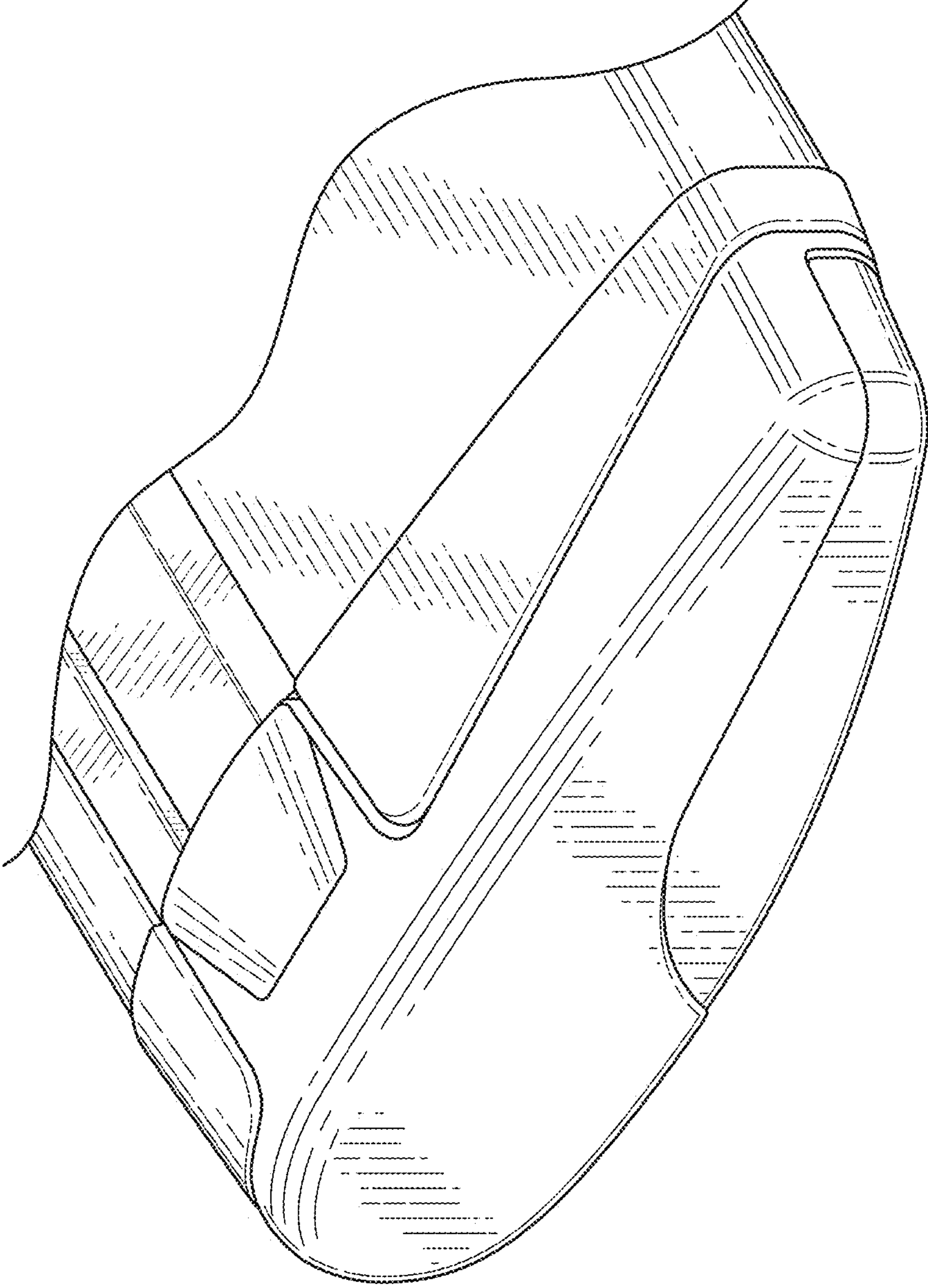

FIG. 13

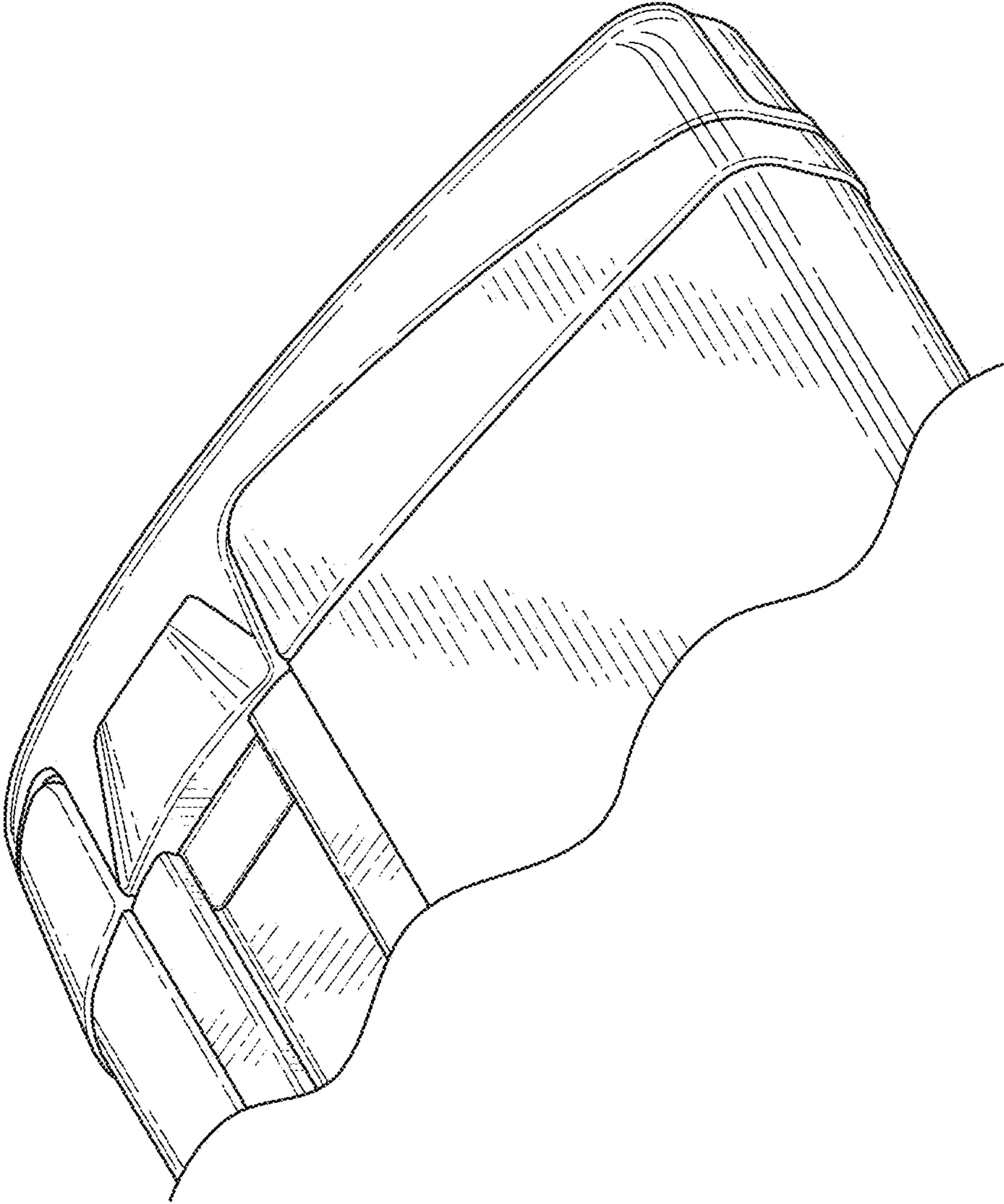

FIG. 14

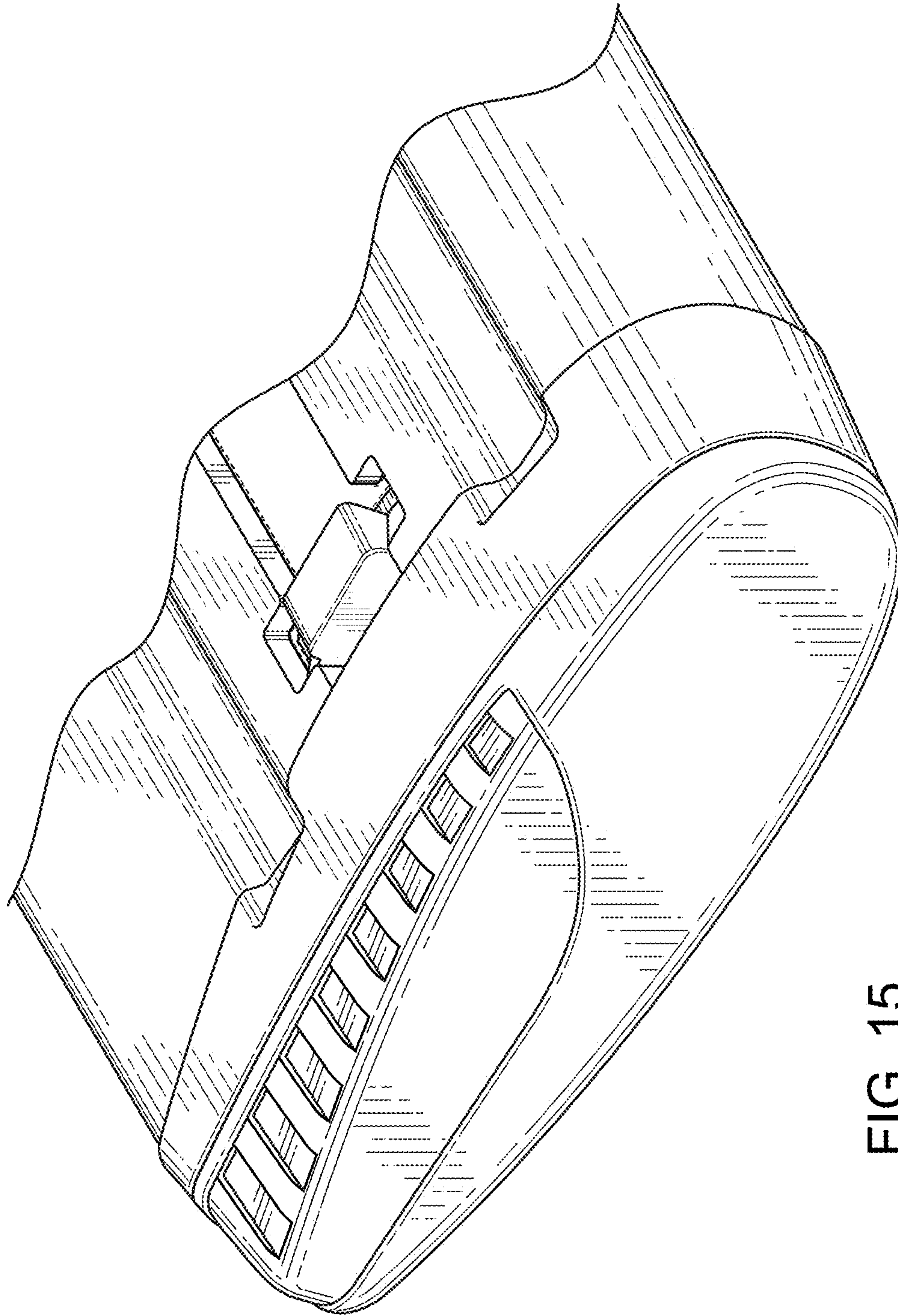

FIG. 15

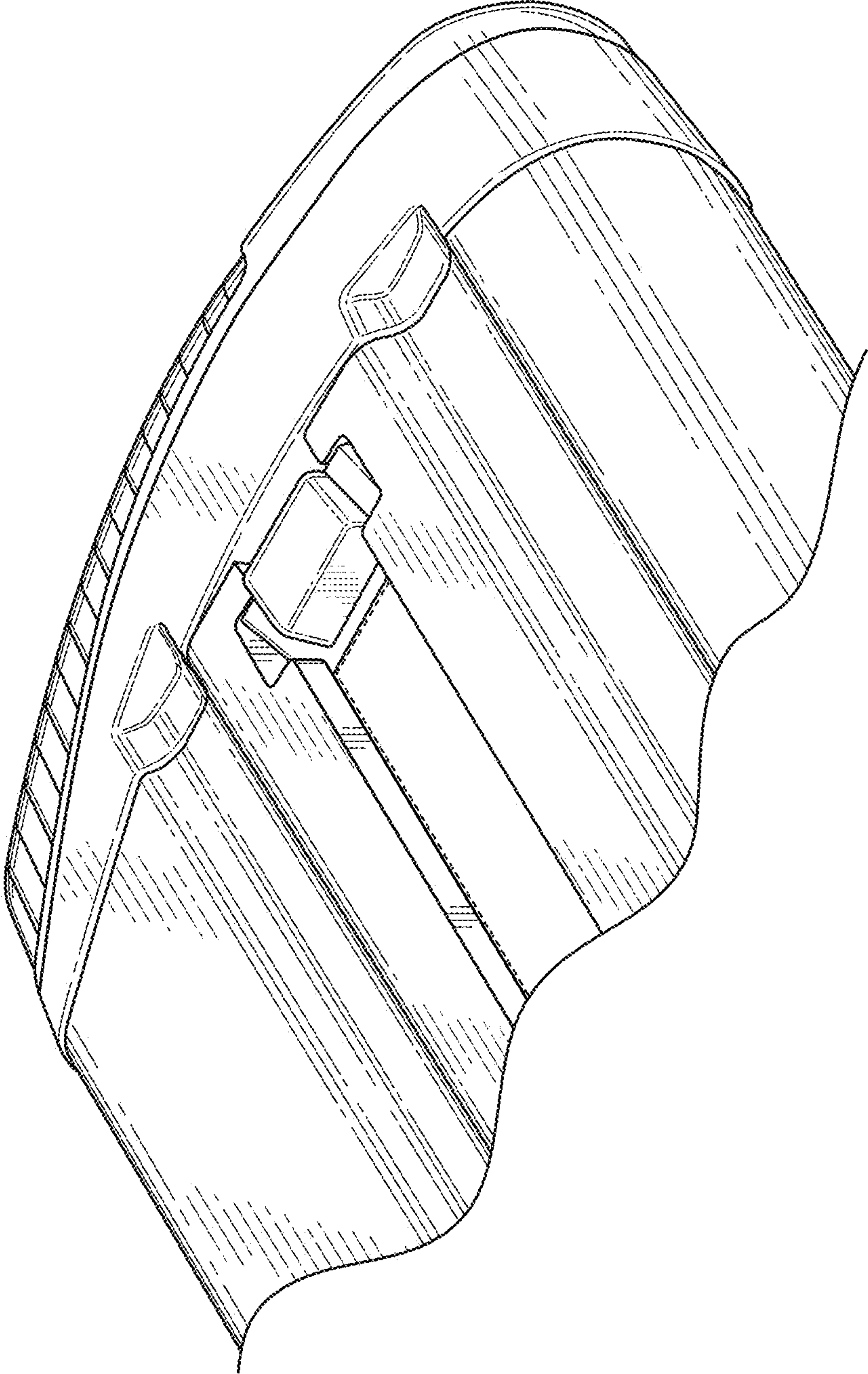

FIG. 16

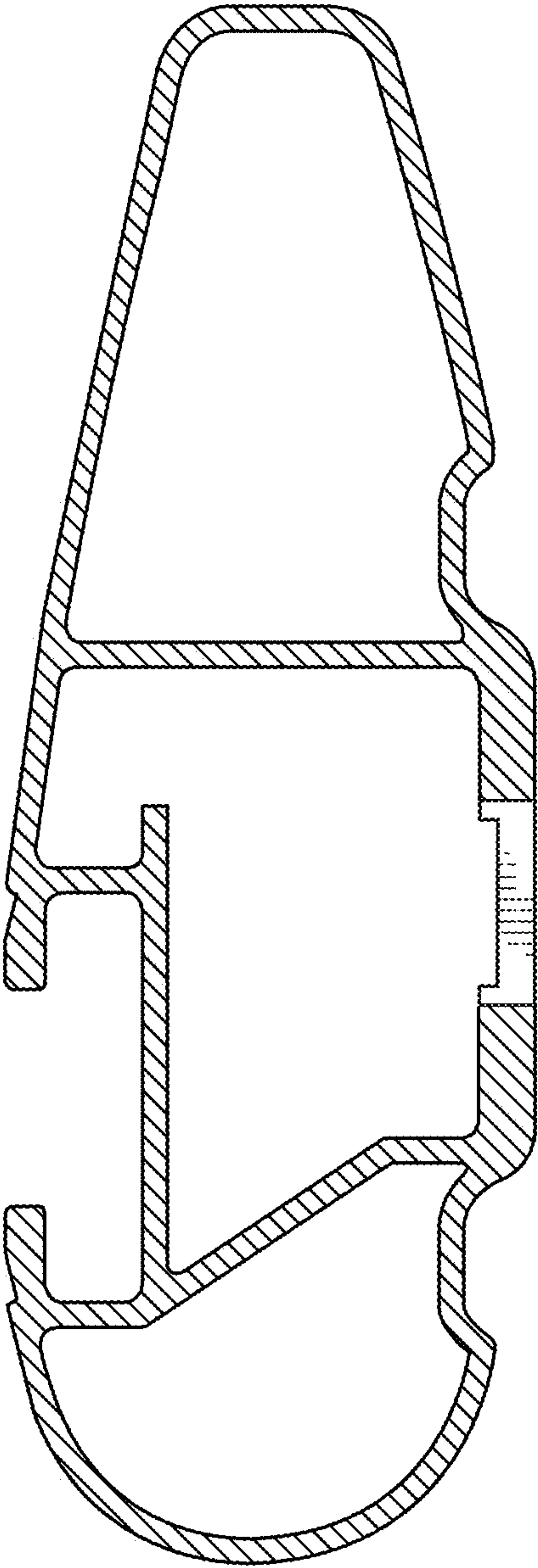

FIG. 17