



US00D691547S

(12) **United States Design Patent**
Hall et al.

(10) **Patent No.:** **US D691,547 S**
(45) **Date of Patent:** **** Oct. 15, 2013**

(54) **AIRPLANE**

D537,029 S * 2/2007 Eakins et al. D12/319
D596,267 S * 7/2009 Colgren et al. D12/319

(75) Inventors: **David W. Hall**, Morro Bay, CA (US);
Darold B. Cummings, Coeur d'Alene,
ID (US); **Benjamin T. Schiltgen**, San
Luis Obispo, CA (US); **Andrew R.**
Gibson, Santa Maria, CA (US); **Michael**
W. Green, San Luis Obispo, CA (US)

(Continued)

OTHER PUBLICATIONS

Aviation Week & Space Technology, Jun. 4/11, 2012, pp. 62 and 63.

(Continued)

(73) Assignee: **Empirical Systems Aerospace, Inc.**,
Oceano, CA (US)

Primary Examiner — Caron D Veynar
Assistant Examiner — Martie K Holtje

(74) *Attorney, Agent, or Firm* — Morland C. Fischer

(**) Term: **14 Years**

(57) **CLAIM**

The ornamental design for an airplane, as shown and
described.

(21) Appl. No.: **29/424,397**

DESCRIPTION

(22) Filed: **Jun. 12, 2012**

(51) **LOC (9) Cl.** **12-07**

(52) **U.S. Cl.**
USPC **D12/319; D12/341**

(58) **Field of Classification Search**
USPC D12/319, 326, 327, 328, 329, 331–334,
D12/337, 338, 339, 343, 344, 345, 16.1;
D21/430, 441, 442, 446, 447, 448, 449,
D21/450, 451, 452, 453; 244/2, 5, 6, 7 C,
244/7 R, 7 A, 12.1, 12.3, 12.4, 17.11, 17.19,
244/17.23, 17.27, 99.1, 118.5, 60, 63, 54,
244/55; 342/2; 280/1.12; 446/230, 231,
446/232, 233, 235, 30–33, 56, 61, 62, 66,
446/69

FIG. 1 is a perspective view showing the top, right side and
front for a first embodiment of an airplane which forms our
new design;
FIG. 2 is a front elevational view thereof;
FIG. 3 is a rear elevational view thereof;
FIG. 4 is a right side elevational view thereof, drawn to an
enlarged scale;
FIG. 5 is a left side elevational view thereof, drawn to an
enlarged scale;
FIG. 6 is a top plan view thereof;
FIG. 7 is a bottom plan view thereof;
FIG. 8 is a perspective view showing the top, right side and
front for a second embodiment of an airplane which forms our
new design;
FIG. 9 is a front elevational view thereof;
FIG. 10 is a rear elevational view thereof;
FIG. 11 is a right side elevational view thereof, drawn to an
enlarged scale;
FIG. 12 is a left side elevational view thereof, drawn to an
enlarged scale;
FIG. 13 is a top plan view thereof; and,
FIG. 14 is a bottom plan view thereof.

See application file for complete search history.

(56) **References Cited**

U.S. PATENT DOCUMENTS

D214,597 S * 7/1969 Cathers et al. D12/340
3,666,211 A * 5/1972 Cathers et al. 244/54
4,924,228 A * 5/1990 Novak et al. 342/2
D517,467 S * 3/2006 Vigneron et al. D12/319
D529,857 S * 10/2006 Eakins et al. D12/319

1 Claim, 10 Drawing Sheets

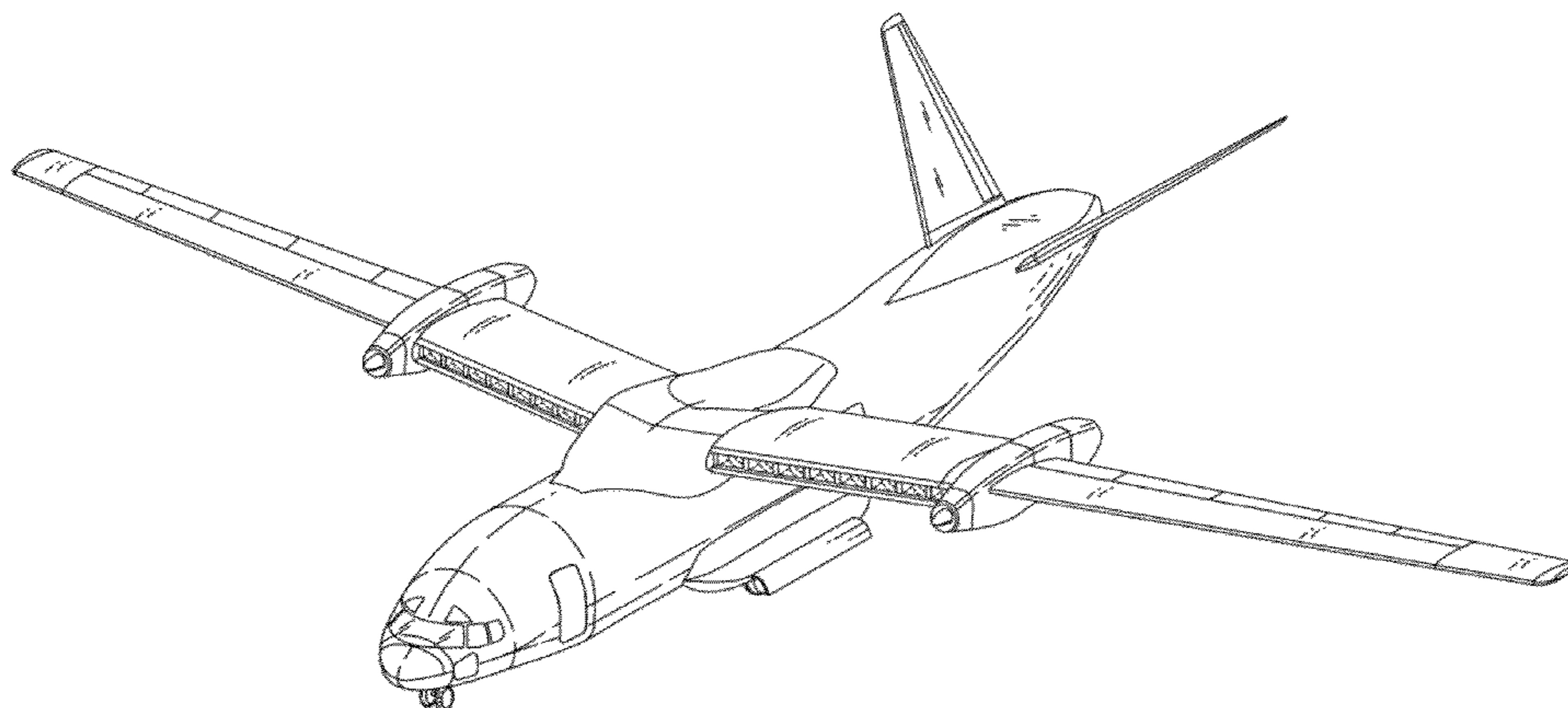

(56)

References Cited

OTHER PUBLICATIONS

U.S. PATENT DOCUMENTS

D624,479 S * 9/2010 Guering D12/343
D624,480 S * 9/2010 Guering D12/343
D628,528 S * 12/2010 Cabezas Carrasco D12/319
7,905,449 B2 * 3/2011 Cazals et al. 244/55
D665,331 S * 8/2012 Sands D12/319

Aviation Week & Space Technology, Apr. 2, 2012, p. 20.

Picture slides presented by NASA, Mar. 13, 2012, 3 pages.

* cited by examiner

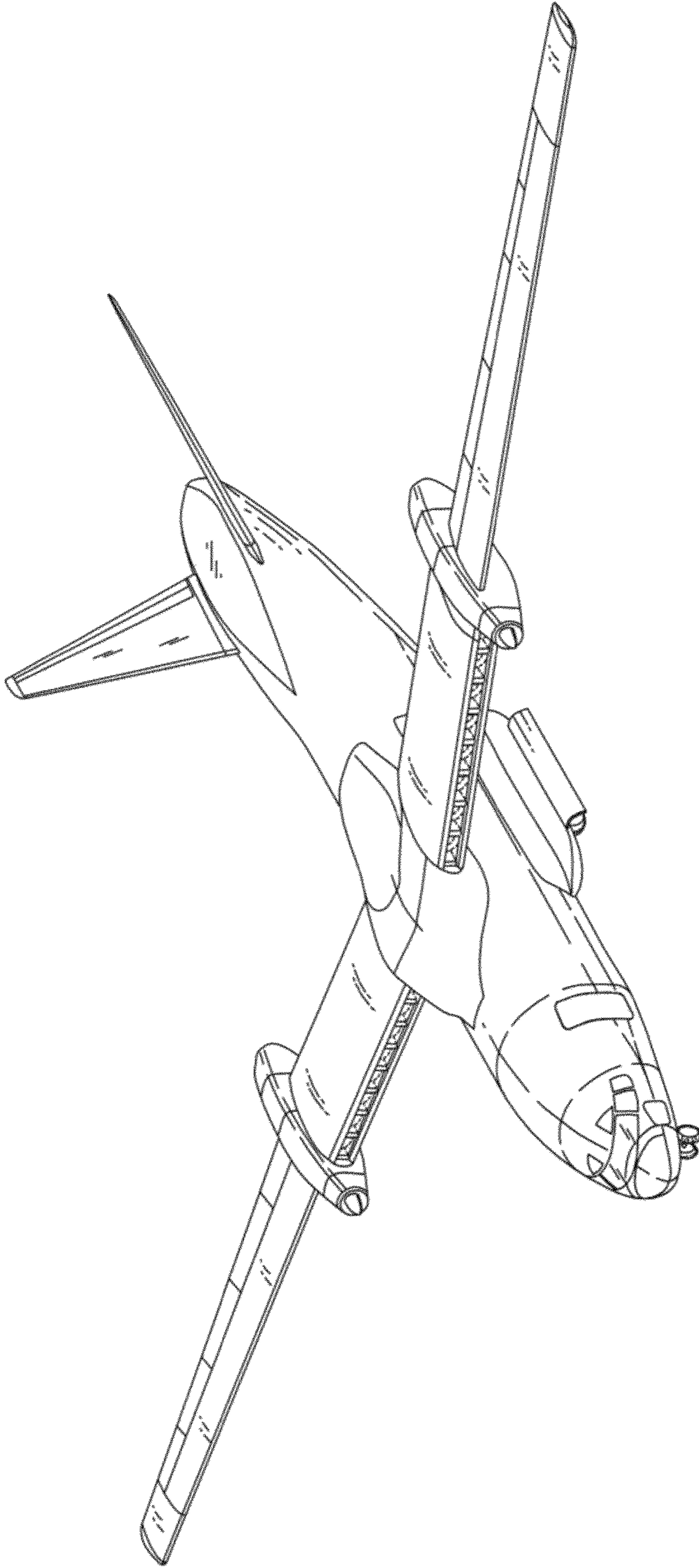

Fig. 1

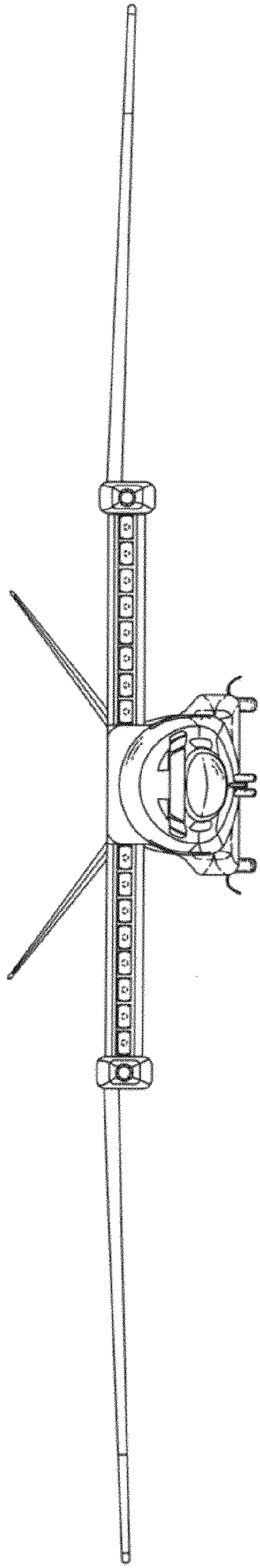

Fig. 2

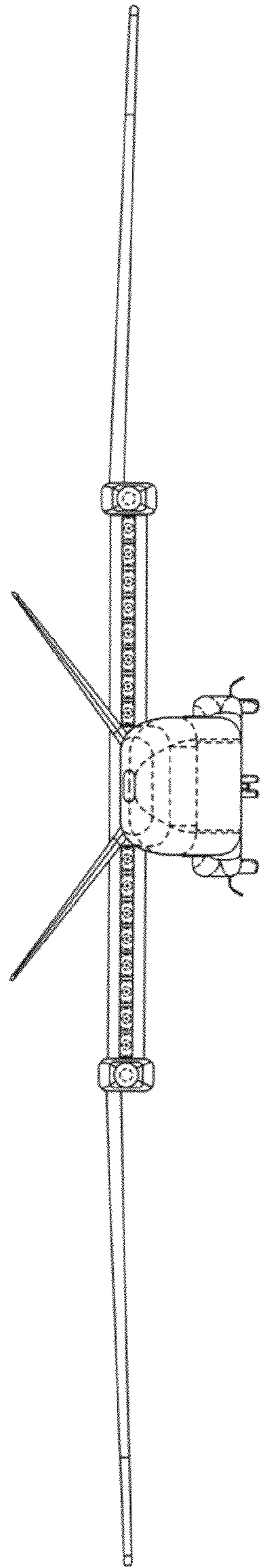

Fig. 3

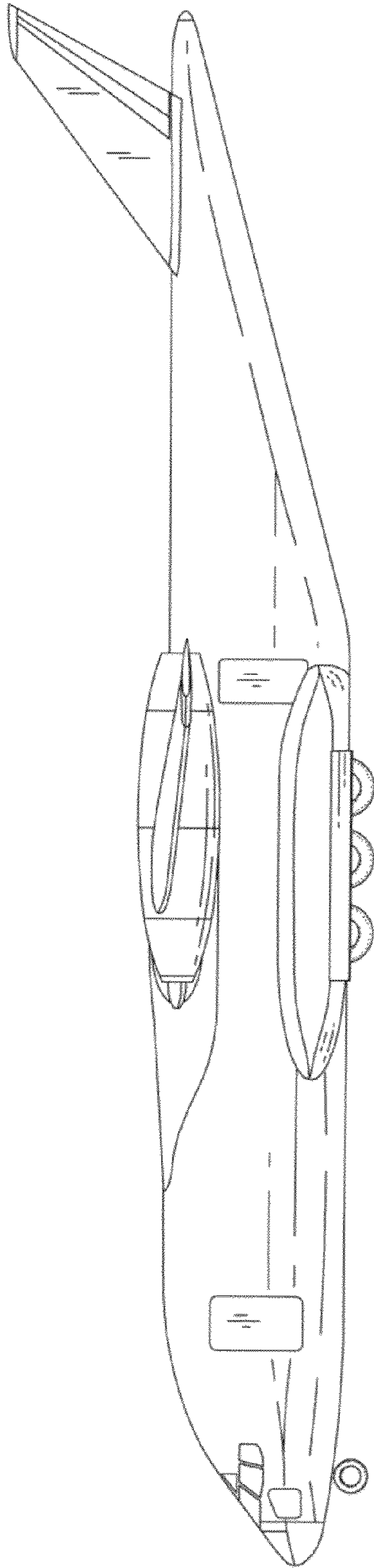

Fig. 4

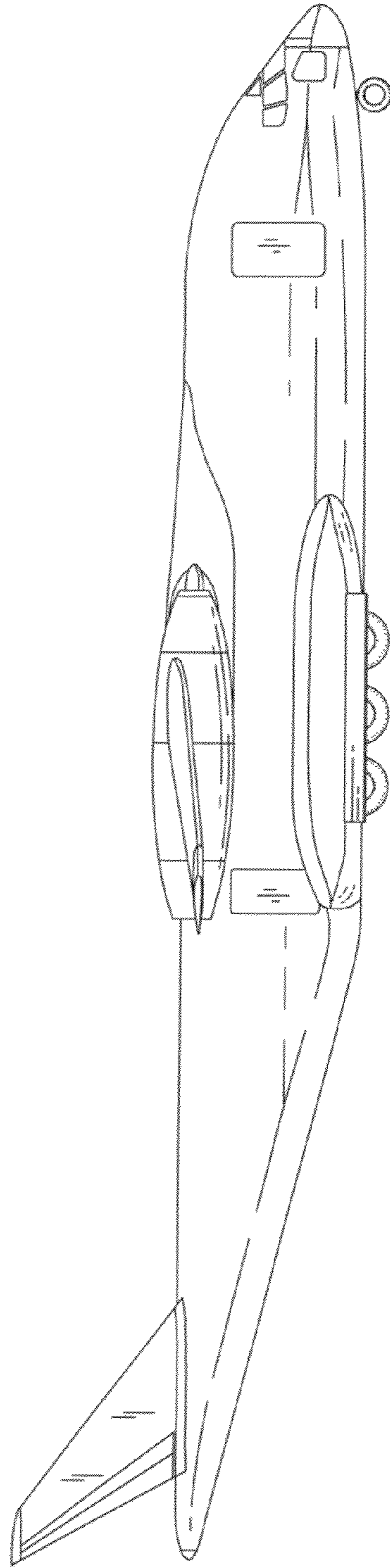

Fig. 5

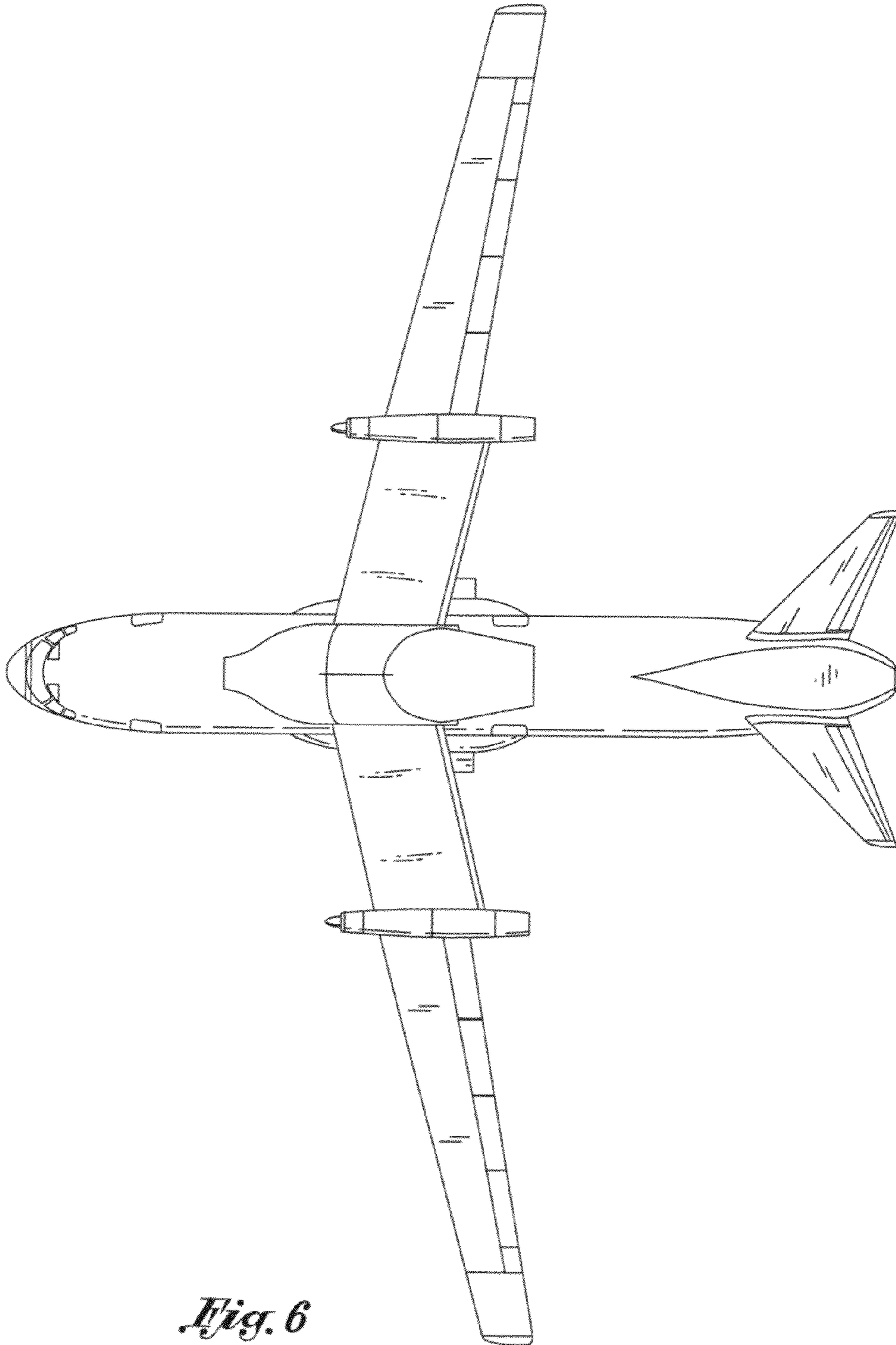

Fig. 6

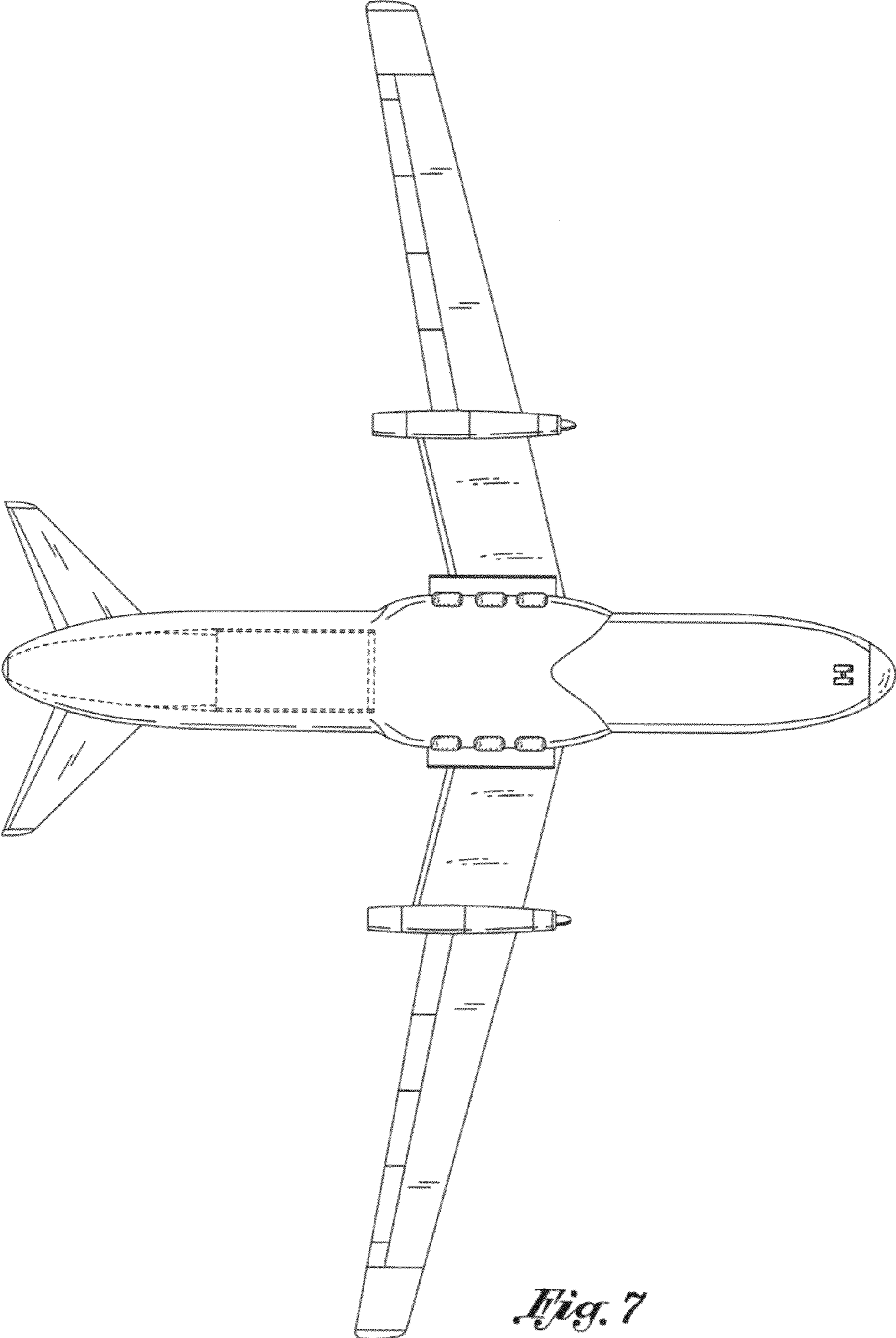

Fig. 7

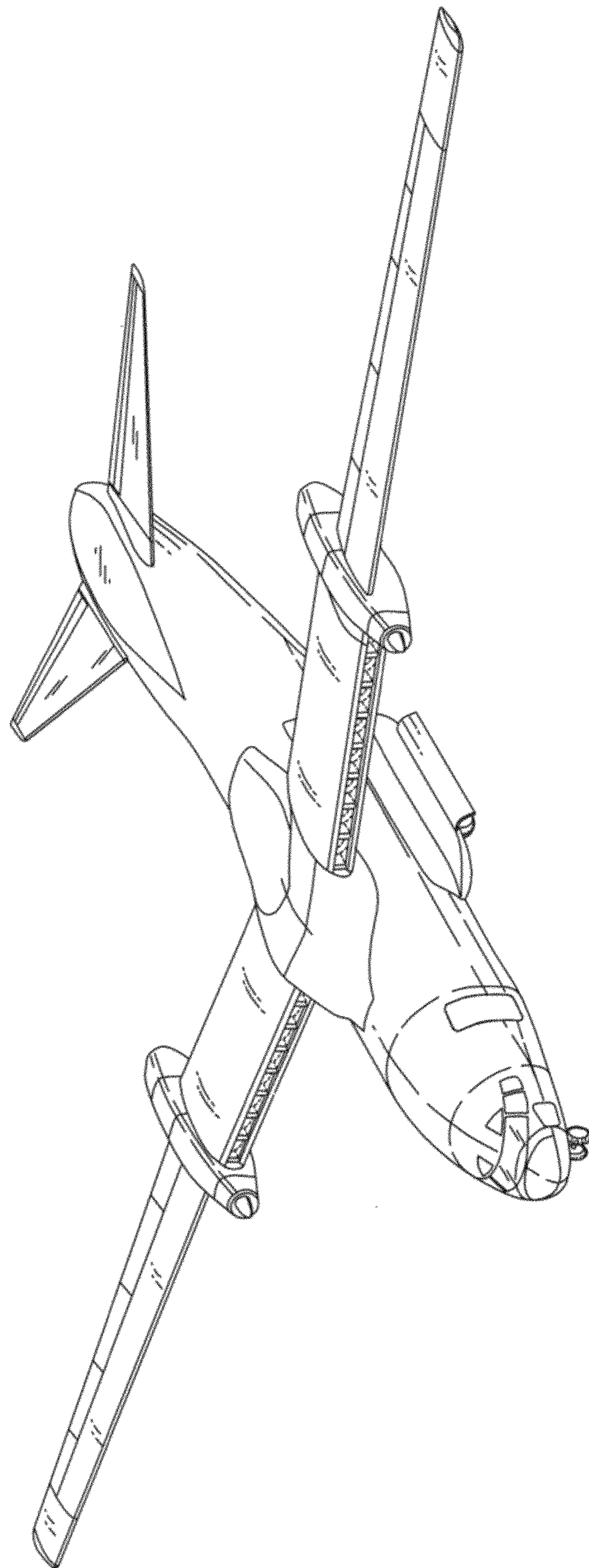

Fig. 8

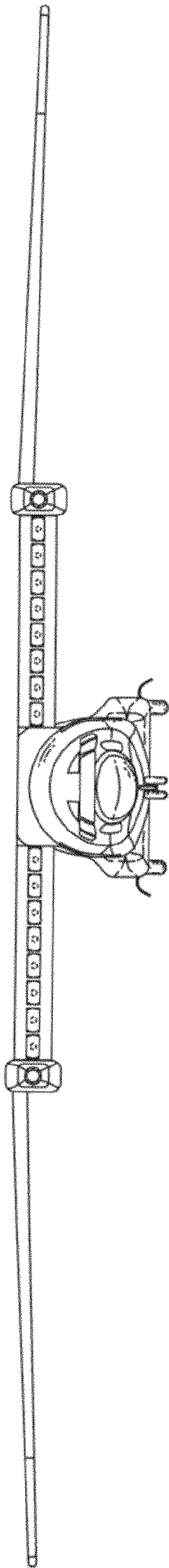

Fig. 9

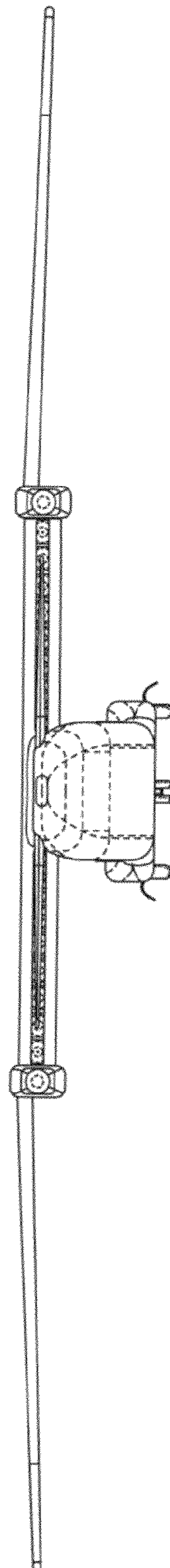

Fig. 10

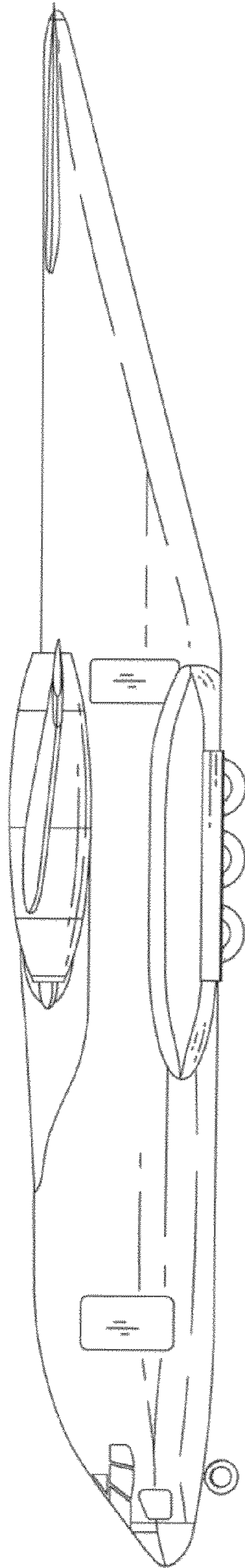

Fig. 11

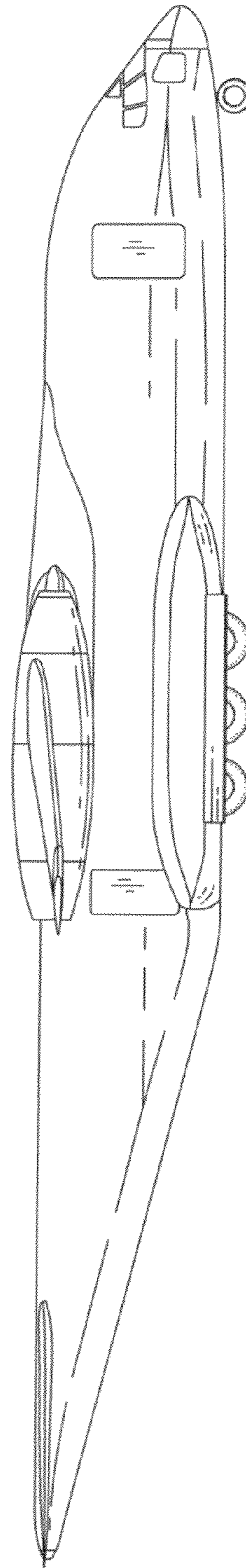

Fig. 12

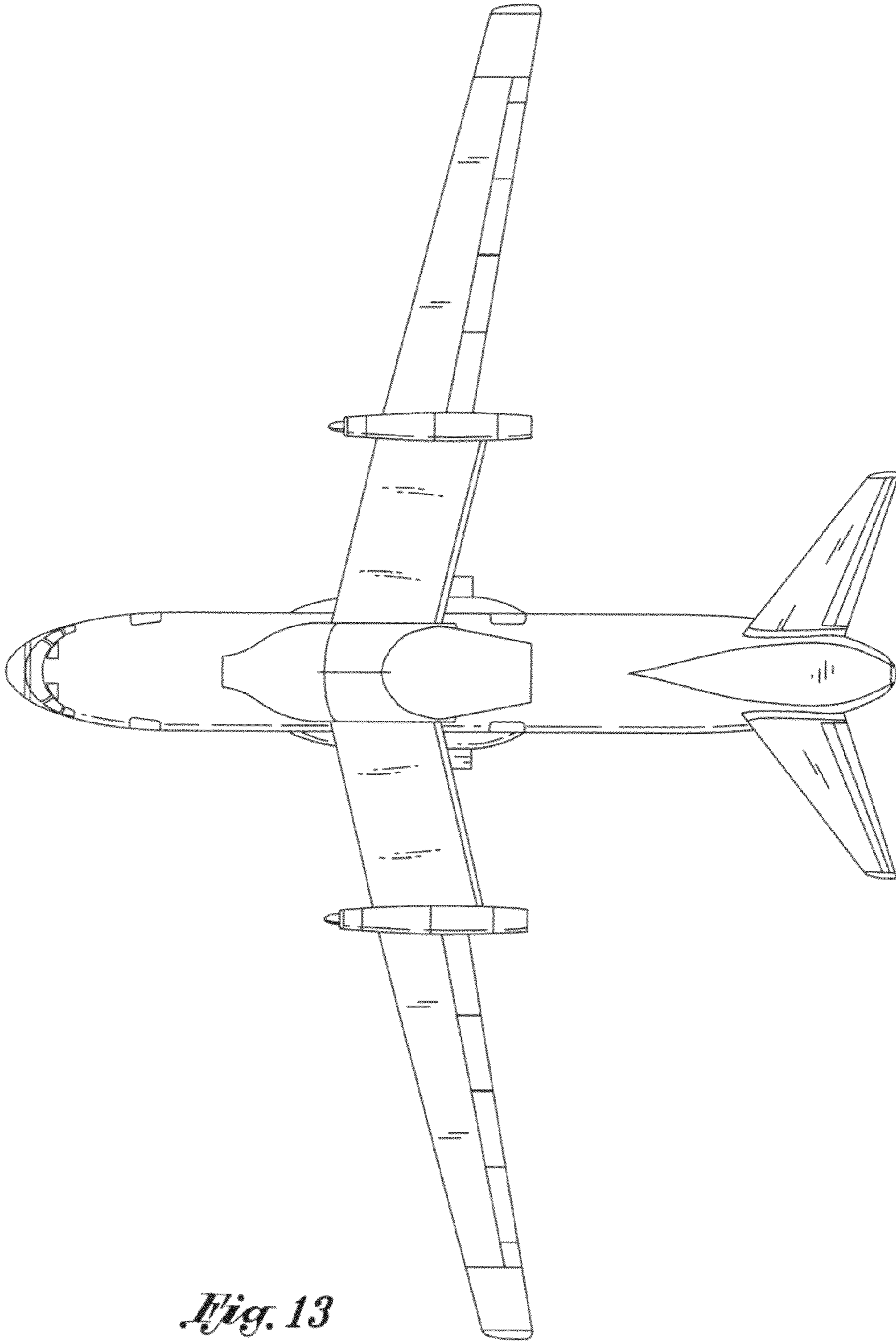

Fig. 13

