



US00D691521S

(12) **United States Design Patent**
Dunshee

(10) **Patent No.:** **US D691,521 S**
(45) **Date of Patent:** **** Oct. 15, 2013**

(54) **MOTORCYCLE**

(75) Inventor: **Erik Dunshee**, Los Angeles, CA (US)

(73) Assignee: **Honda Motor Co., Ltd.**, Tokyo (JP)

(**) Term: **14 Years**

(21) Appl. No.: **29/427,708**

(22) Filed: **Jul. 20, 2012**

Related U.S. Application Data

(63) Continuation-in-part of application No. 29/381,242, filed on Dec. 16, 2010, now Pat. No. Des. 666,531.

(51) **LOC (9) Cl.** **12-11**

(52) **U.S. Cl.**
USPC **D12/110**

(58) **Field of Classification Search**
USPC D12/110; 180/219, 220
See application file for complete search history.

(56) **References Cited**

U.S. PATENT DOCUMENTS

D470,800 S *	2/2003	Muta et al.	D12/110
D476,271 S *	6/2003	Abe et al.	D12/110
D531,936 S *	11/2006	Ito et al.	D12/110
D567,715 S *	4/2008	Brew et al.	D12/110
D615,000 S *	5/2010	Tako et al.	D12/110
D624,853 S *	10/2010	Song et al.	D12/110

OTHER PUBLICATIONS

2009/2010 International Motorcycle Show article. © 2000-2011. The Custom Star Stratoliner Deluxe on p. 3 of 11 and the Slammer on p.

4 of 11. [Retrieved on Aug. 15, 2011]. Retrieved from the Internet<URL: <http://www.bikeland.org/story.php?storyID=59365>>.*

1999 and 2003-2008 Baggers annotated on pp. 1-4 and 8-11 of 11. [Retrieved on Aug. 16, 2011]. Retrieved from the Internet <URL : <http://www.turboyourharley.com/turboBikes.asp>>.*

* cited by examiner

Primary Examiner — Susan M Lee

Assistant Examiner — Linda Brooks

(74) *Attorney, Agent, or Firm* — Plumsea Law Group, LLC

(57) **CLAIM**

The ornamental design for a motorcycle, as shown and described.

DESCRIPTION

FIG. 1 is a left frontal perspective view of a motorcycle showing my new design;

FIG. 2 is a right frontal perspective view thereof;

FIG. 3 is a right rear perspective view thereof;

FIG. 4 is a left rear perspective view thereof;

FIG. 5 is a right side view thereof;

FIG. 6 is a left side view thereof;

FIG. 7 is a front view thereof;

FIG. 8 is a rear view thereof;

FIG. 9 is a detailed view of the fuel tank, handle bars and front fairing thereof; and,

FIG. 10 is a top view thereof.

The broken lines show portions of the motorcycle that form no part of the claimed design.

1 Claim, 9 Drawing Sheets

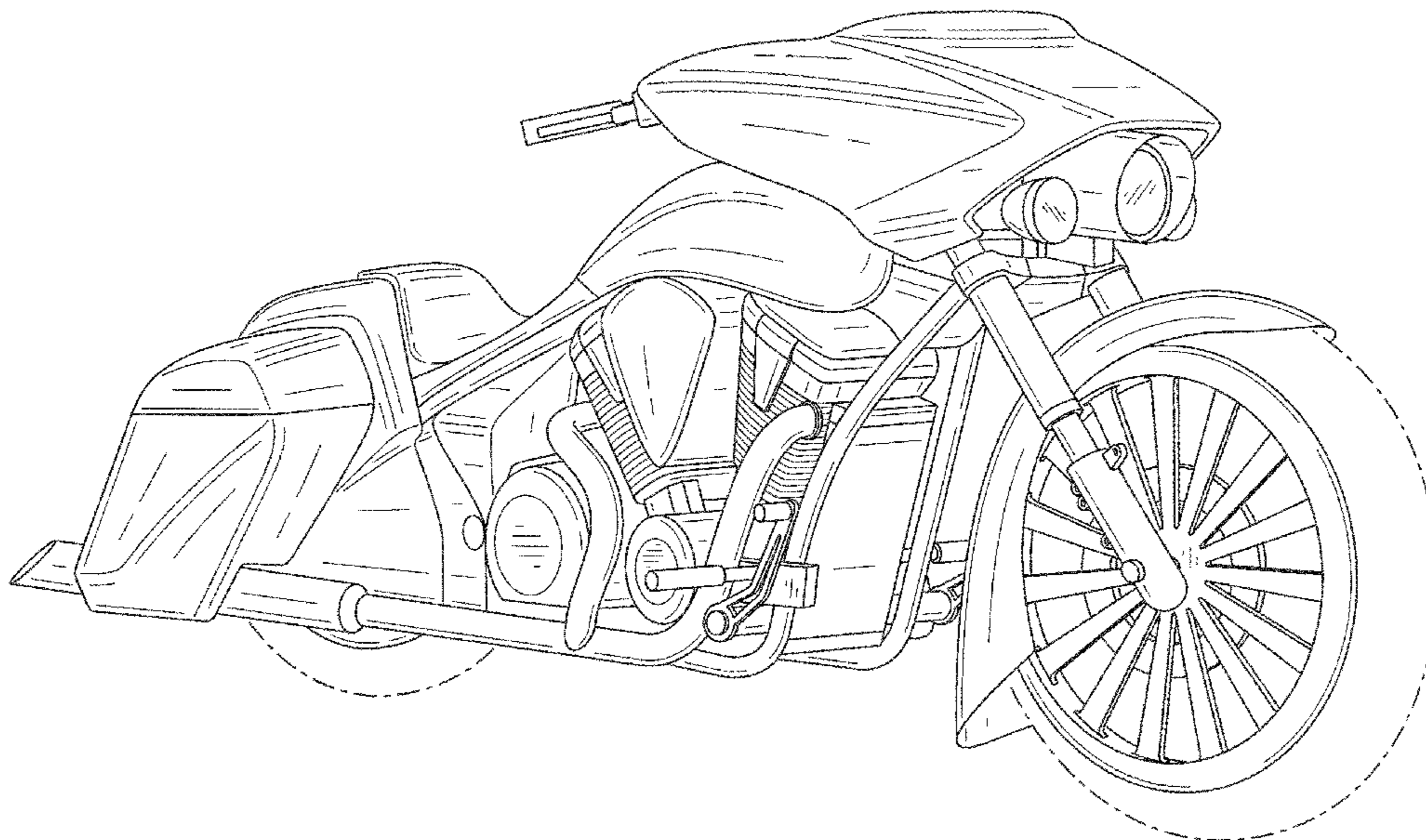

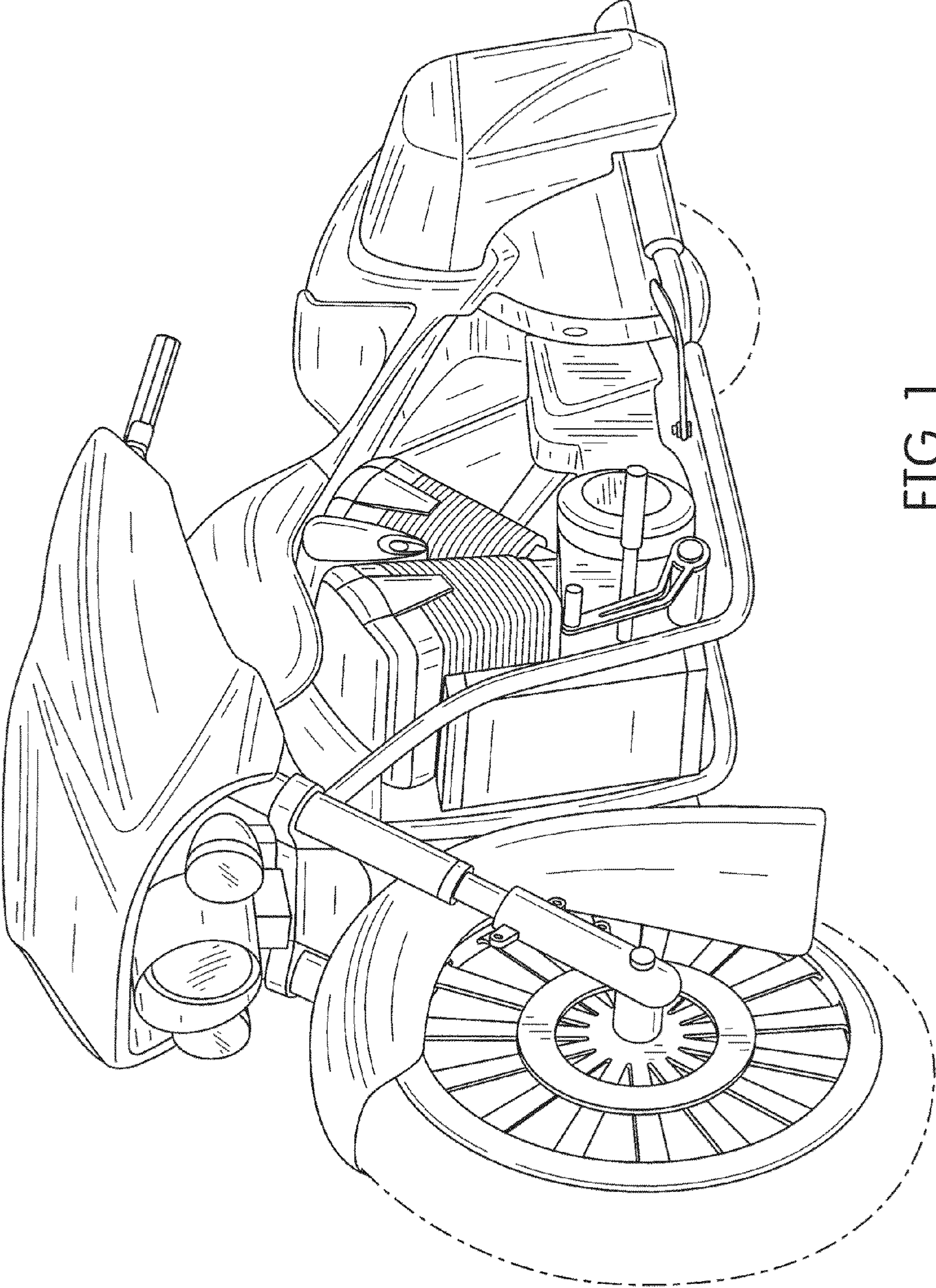

FIG. 1

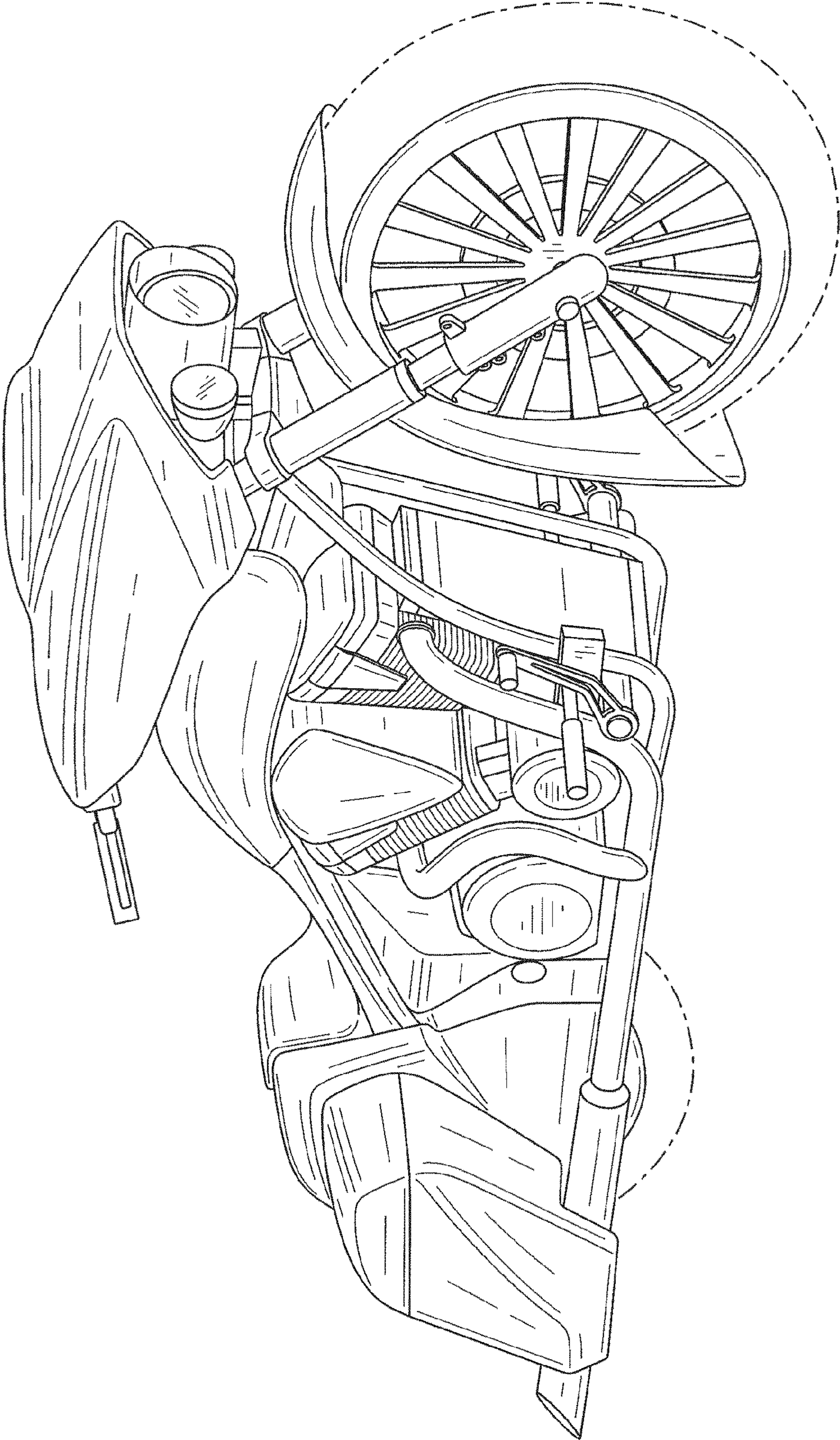

FIG. 2

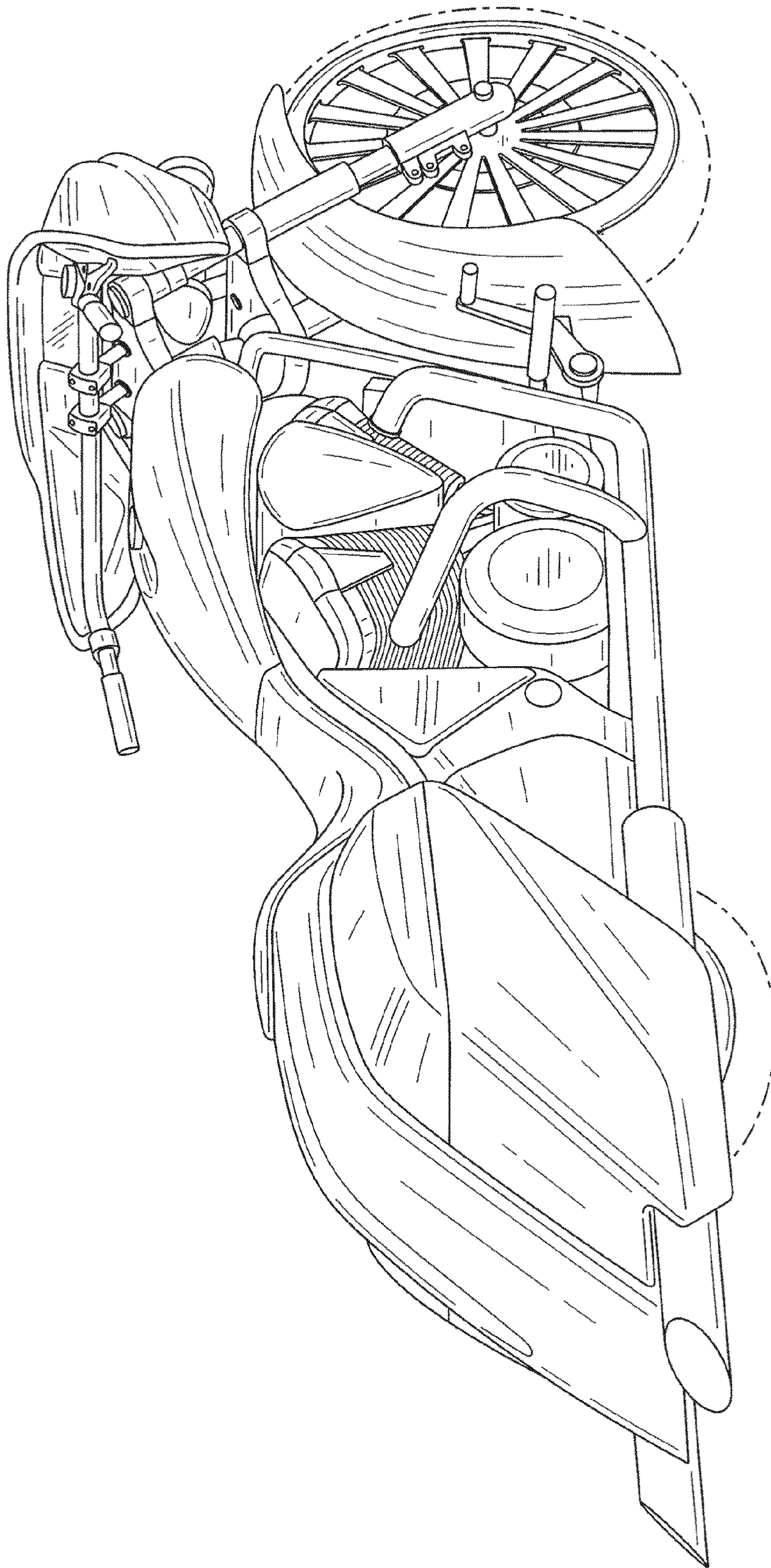

FIG. 3

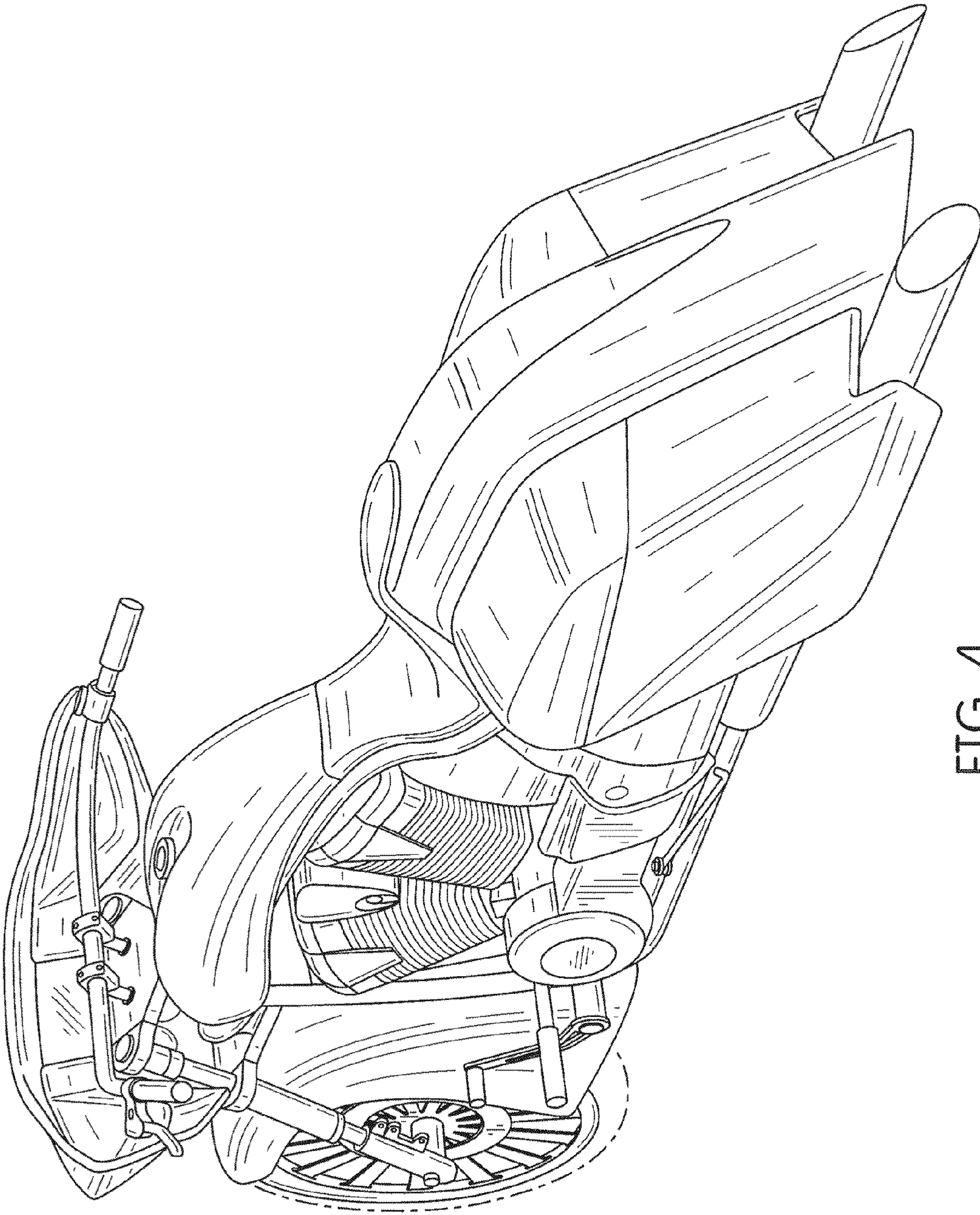

FIG. 4

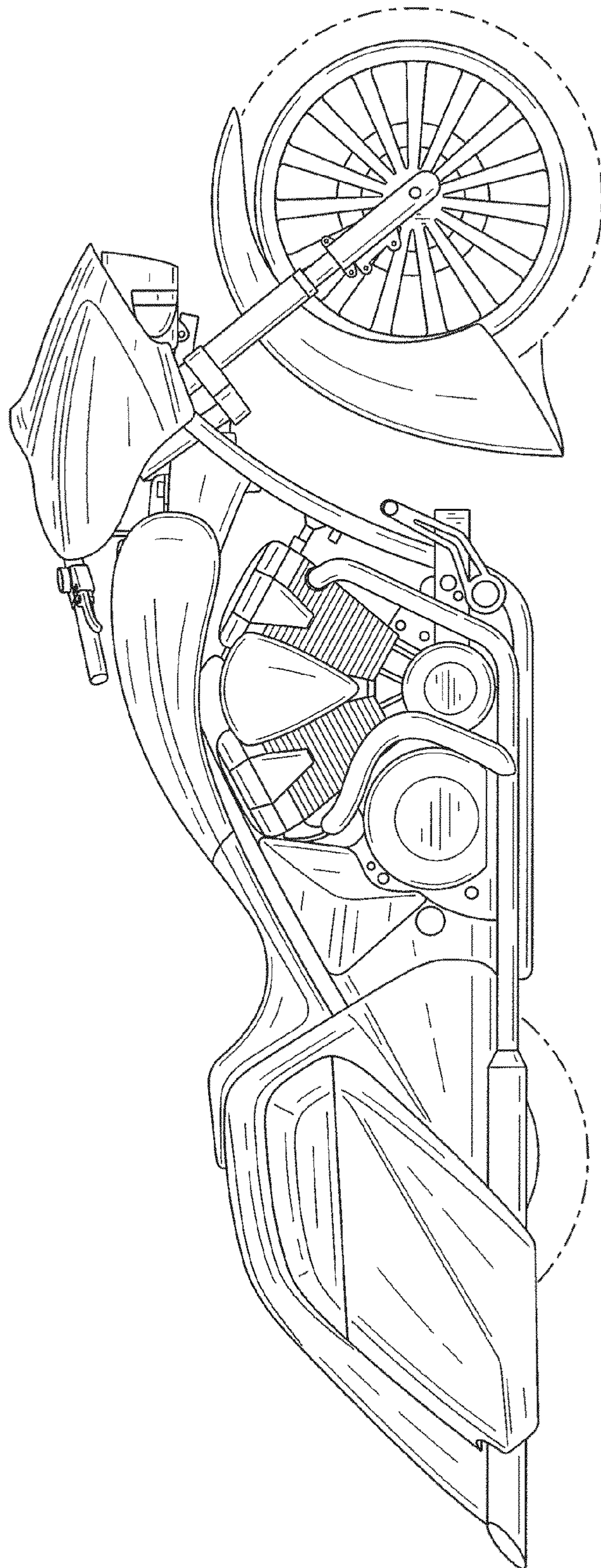

FIG. 5

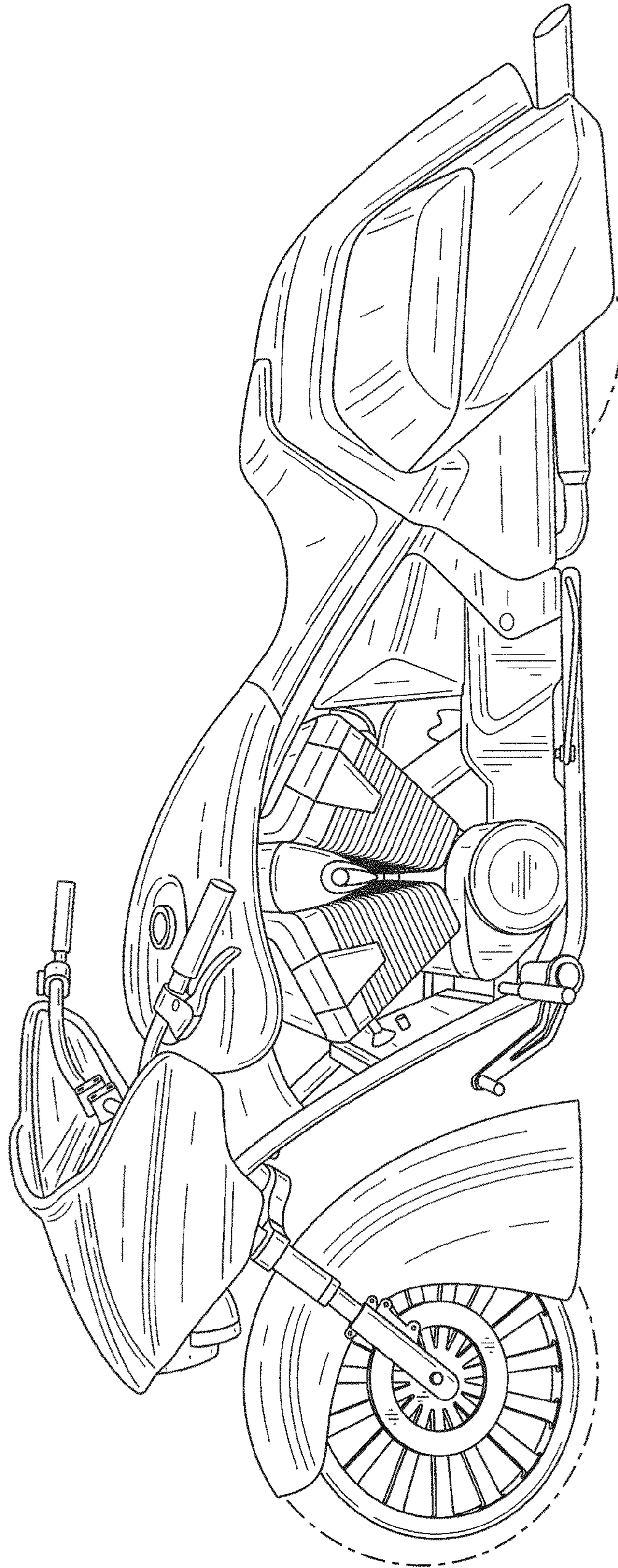

FIG. 6

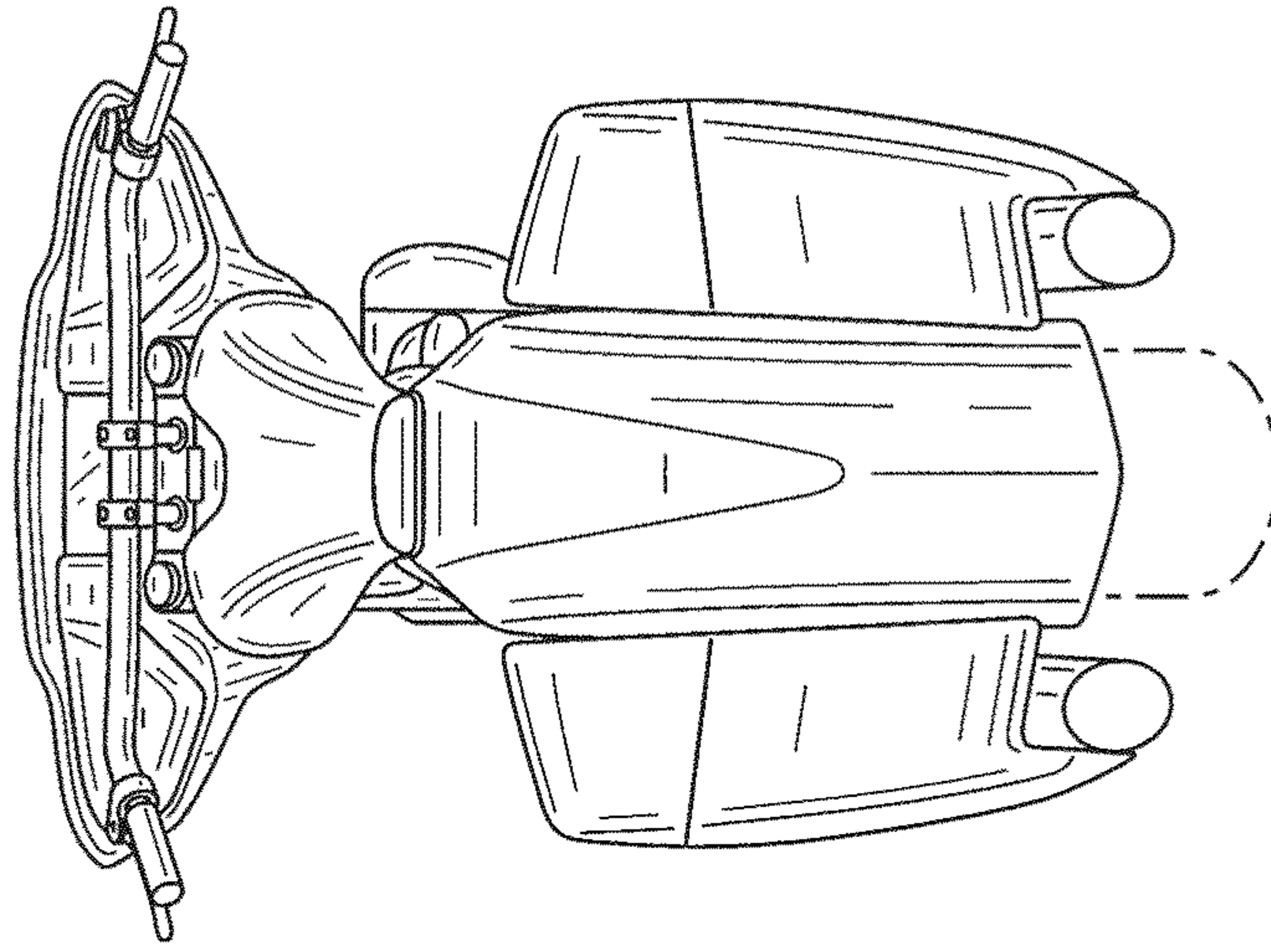

FIG. 8

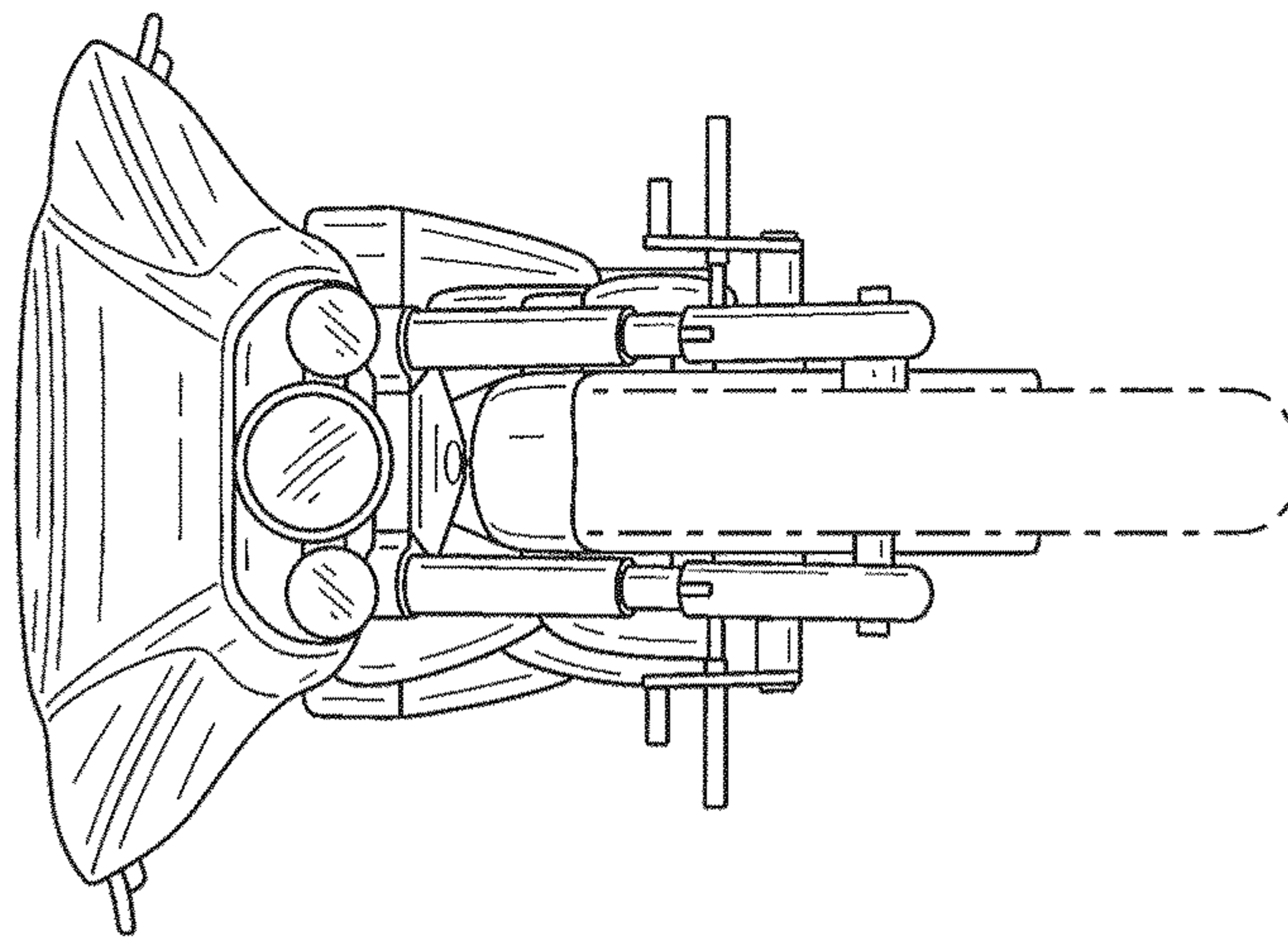

FIG. 7

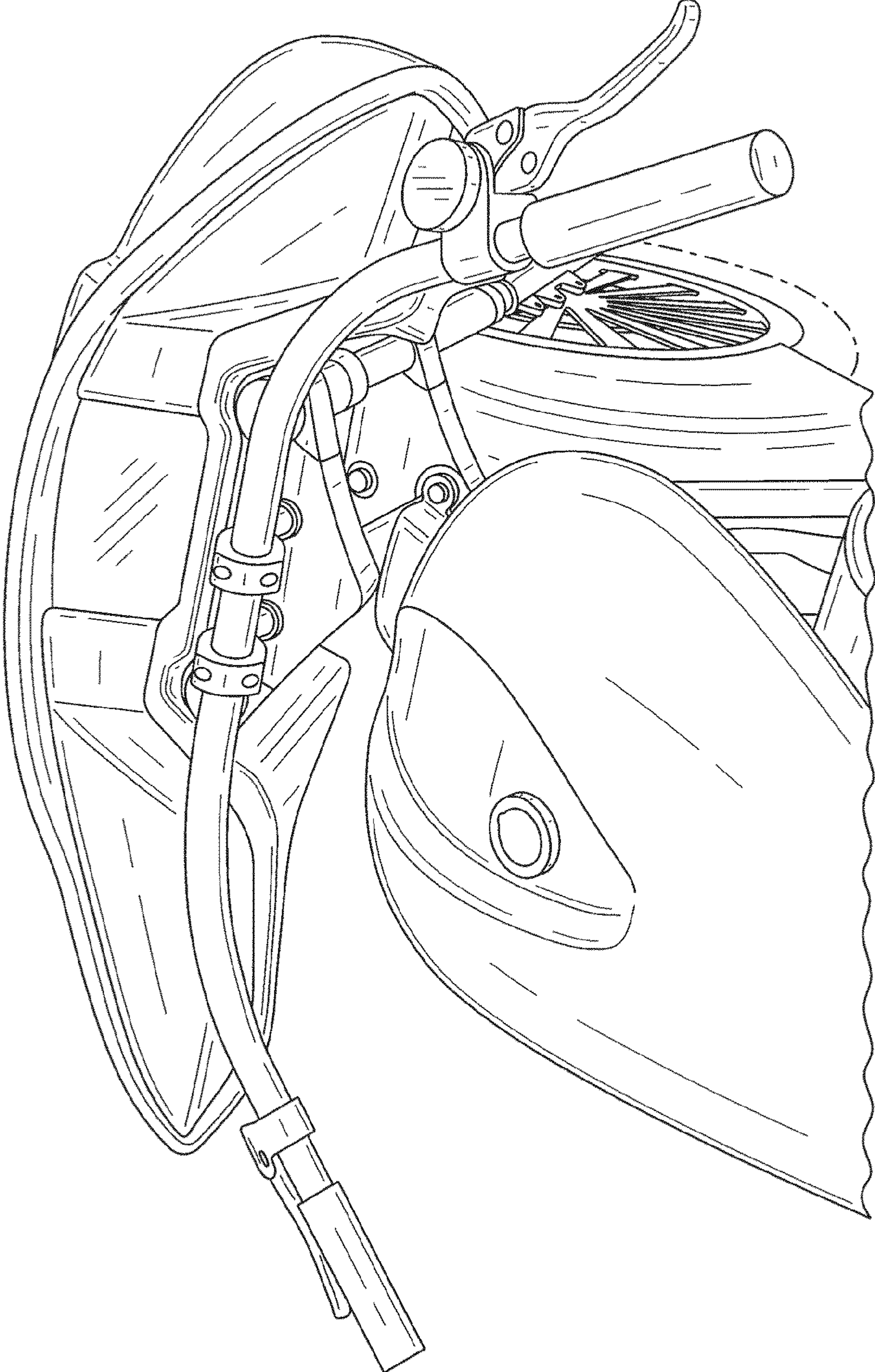

FIG. 9

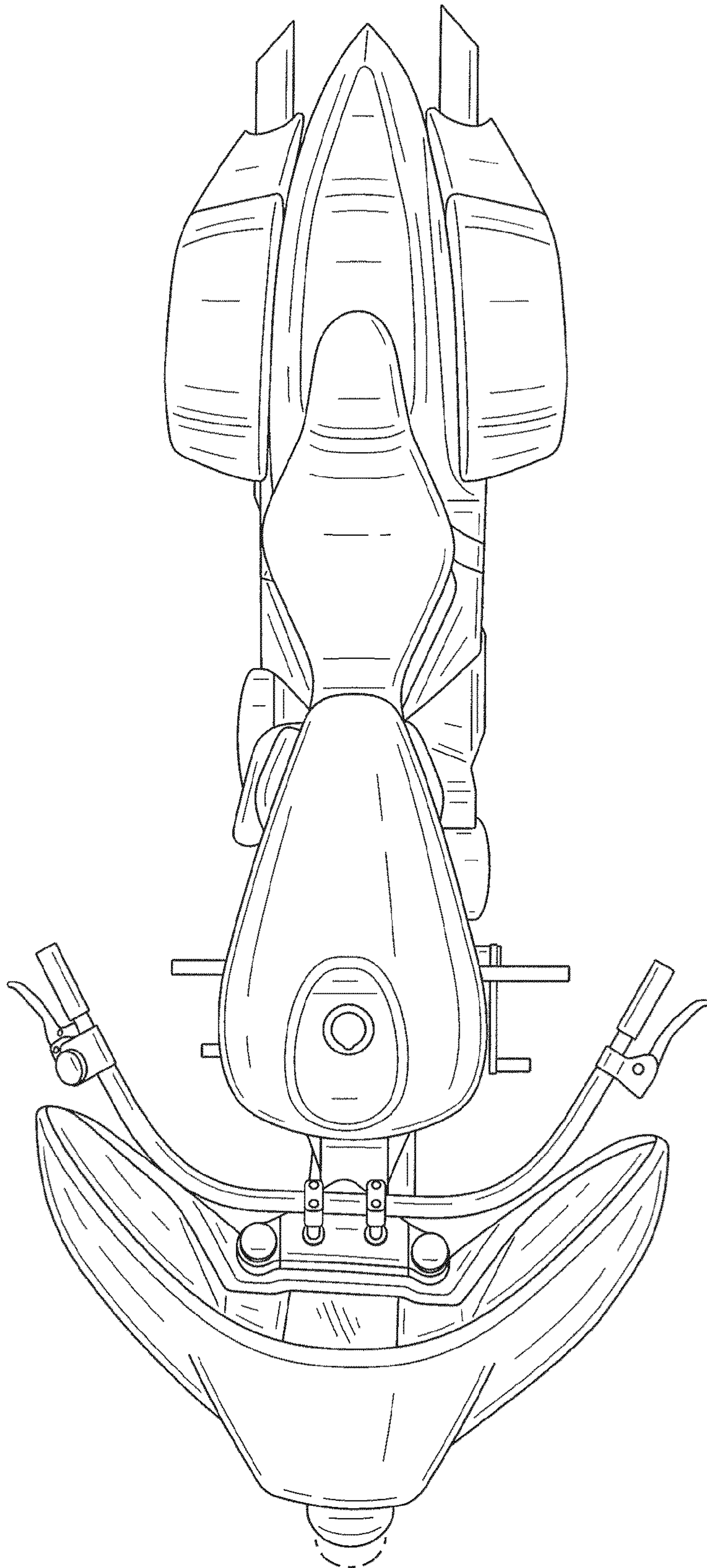

FIG. 10