



US00D691517S

(12) **United States Design Patent**
Kwon et al.

(10) **Patent No.:** **US D691,517 S**
(45) **Date of Patent:** **** Oct. 15, 2013**

(54) **AUTOMOBILE AND/OR TOY REPLICA THEREOF**

(75) Inventors: **Pansoo Kwon**, Toyota (JP); **Shinno Kato**, Toyota (JP); **Yuri Kaneda**, Toyota (JP); **Yuji Fujiwara**, Toyota (JP)

(73) Assignee: **Toyota Jidosha Kabushiki Kaisha**, Toyota-shi (Aichi-ken) (JP)

(**) Term: **14 Years**

(21) Appl. No.: **29/425,109**

(22) Filed: **Jun. 20, 2012**

(30) **Foreign Application Priority Data**

Dec. 27, 2011 (JP) 2011-030118
Dec. 27, 2011 (JP) 2011-030132

(51) **LOC (9) Cl.** **12-08**

(52) **U.S. Cl.**
USPC **D12/92**

(58) **Field of Classification Search**
USPC D12/86, 90-92; D21/424, 433, 434;
296/181.1, 181.5
See application file for complete search history.

(56) **References Cited**

U.S. PATENT DOCUMENTS

D561,645 S *	2/2008	Kim et al.	D12/92
D599,708 S *	9/2009	Li et al.	D12/92
D603,297 S *	11/2009	Takahashi	D12/92
D606,901 S *	12/2009	Inukai et al.	D12/92
D611,388 S *	3/2010	Hogios et al.	D12/92
D612,296 S *	3/2010	Miyazaki et al.	D12/92
D612,299 S *	3/2010	Ito et al.	D12/92
D620,985 S *	8/2010	Mochizuki et al.	D12/92
D625,665 S *	10/2010	Kim et al.	D12/92
D629,718 S *	12/2010	Reichman et al.	D12/92
D630,555 S *	1/2011	Koshino et al.	D12/92
D632,223 S *	2/2011	Jacob et al.	D12/92
D638,334 S *	5/2011	Taniko et al.	D12/92
D648,655 S *	11/2011	Bischoff et al.	D12/92

OTHER PUBLICATIONS

Netcarshow.com; Audi A4; Mfg. Audi; http://www.netcarshow.com/audi/2009-a4/1024x768/wallpaper_03.htm; Mar. 2011.
Netcarshow.com; Audi A4; Mfg. Audi; http://www.netcarshow.com/audi/2009-a4/1024x768/wallpaper_10.htm; Mar. 2011.
BMW official site; BMW 5 series (Sedan); Mfg. BMW; <http://www.bmw.co.jp/jp/ja/newvehicles/5series/sedan/2010/showroom/gallery/index.html#mediaID-1>; Mar. 2011.
BMW official site; BMW 5 series (Sedan); Mfg. BMW; <http://www.bmw.co.jp/jp/ja/newvehicles/5series/sedan/2010/showroom/gallery/index.html#mediaID-3>; Mar. 2011.

* cited by examiner

Primary Examiner — Melody Brown

(74) *Attorney, Agent, or Firm* — Finnegan, Henderson, Farabow, Garrett & Dunner, LLP

(57) **CLAIM**

The ornamental design for an automobile and/or toy replica thereof, as shown and described.

DESCRIPTION

FIG. 1 is a front left perspective view of a first embodiment of an automobile and/or toy replica thereof showing our new design;
FIG. 2 is a rear left perspective view thereof;
FIG. 3 is a front view thereof;
FIG. 4 is a rear view thereof;
FIG. 5 is a left side elevation view thereof, the right side view being a mirror image thereof;
FIG. 6 is a top plan view thereof.
FIG. 7 is a front left perspective view of a second embodiment of an automobile and/or toy replica thereof showing our new design;
FIG. 8 is a rear left perspective view thereof;
FIG. 9 is a front view thereof;
FIG. 10 is a rear view thereof;
FIG. 11 is a left side elevation view thereof, the right side view being a mirror image thereof; and,
FIG. 12 is a top plan view thereof.
The bottom view forms no part of the claimed design.

1 Claim, 10 Drawing Sheets

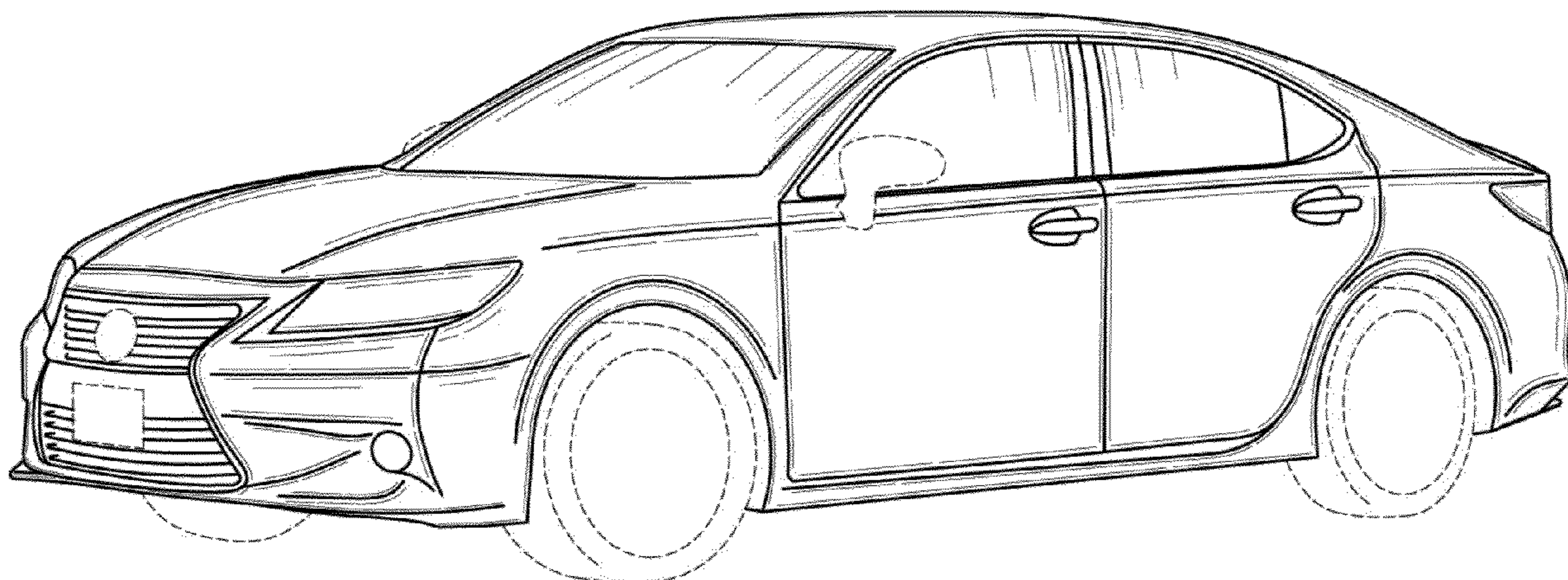

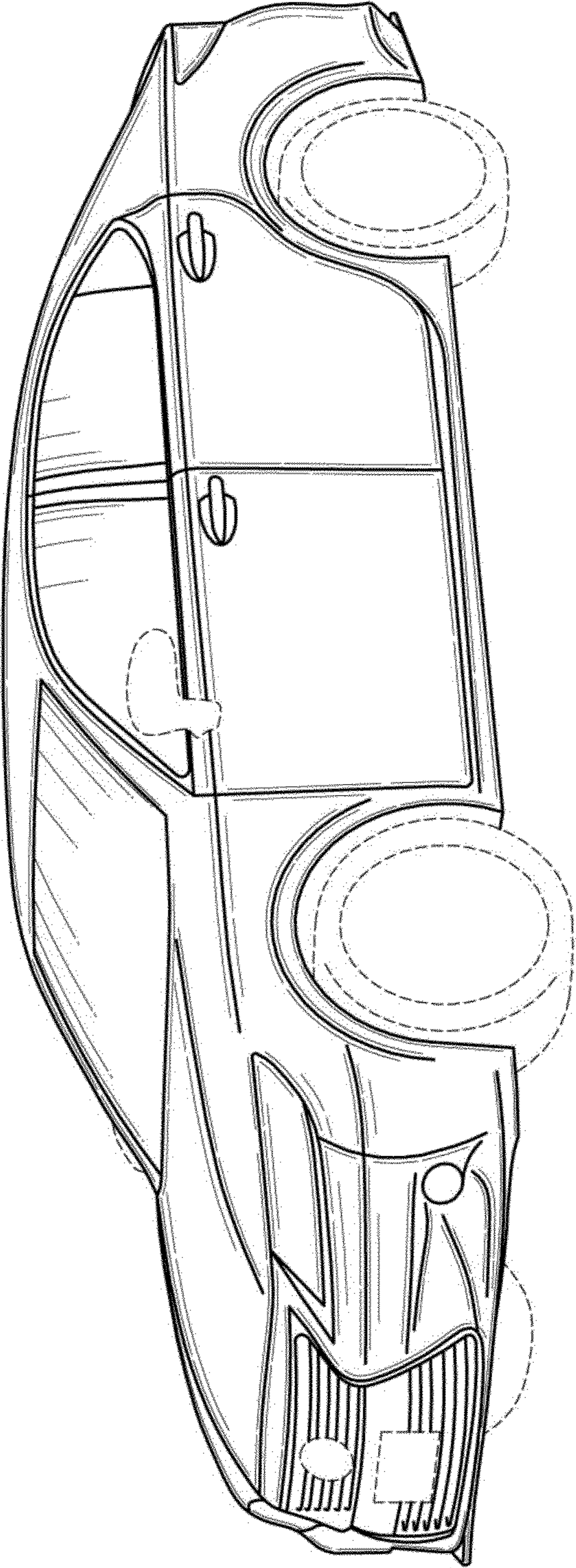

FIG. 1

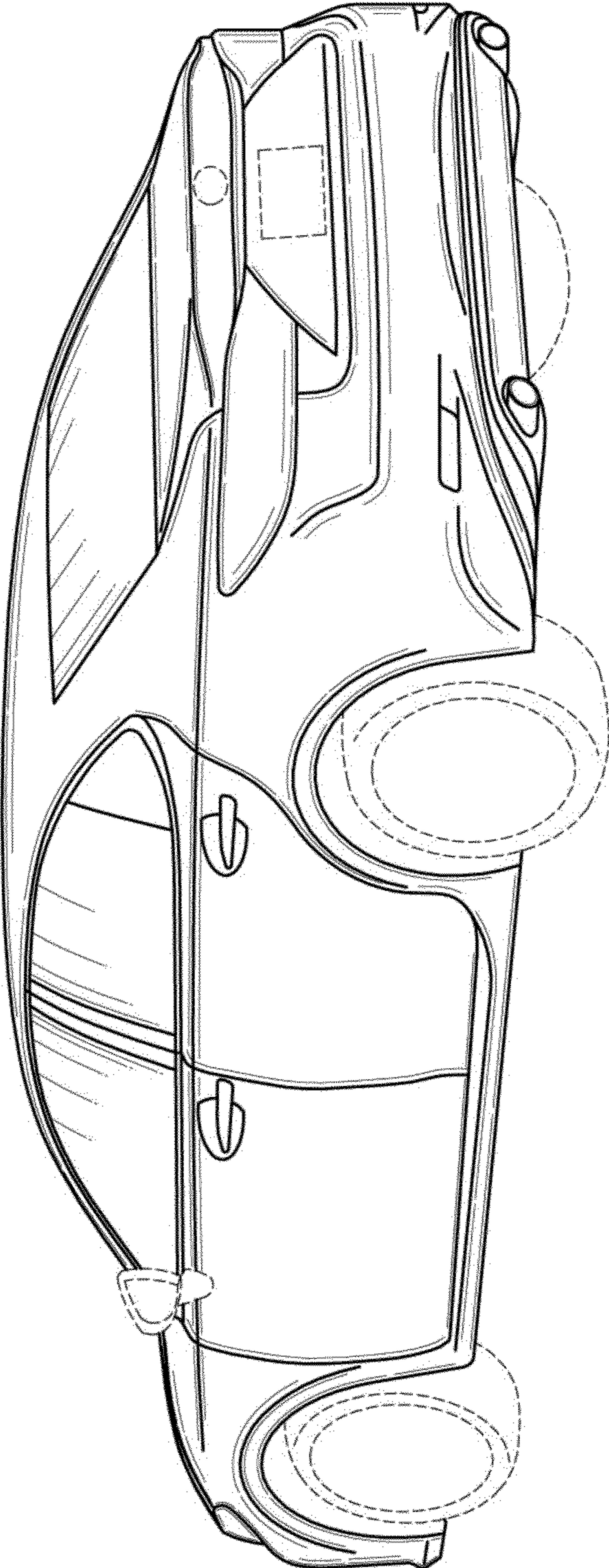

FIG. 2

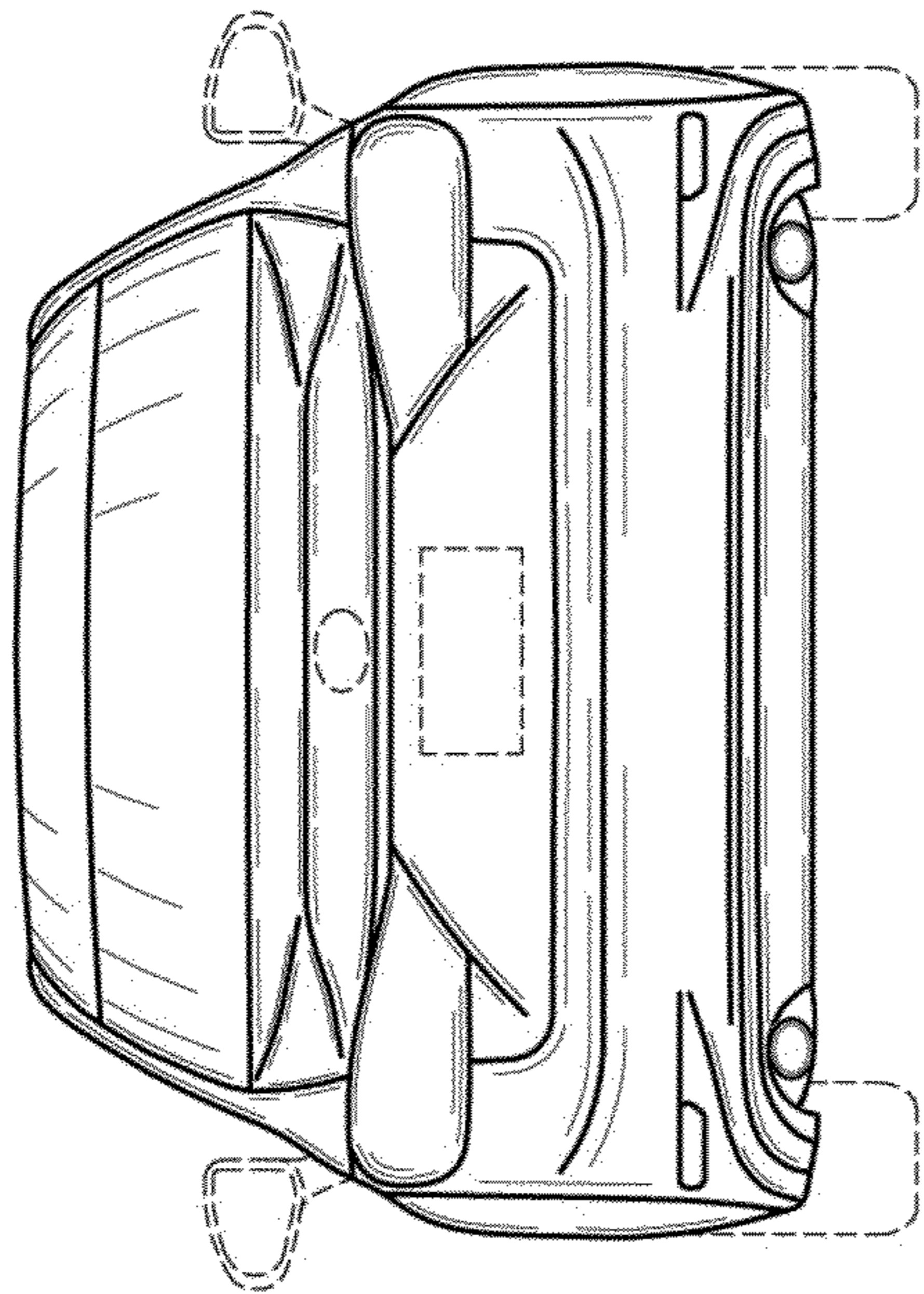

FIG. 3

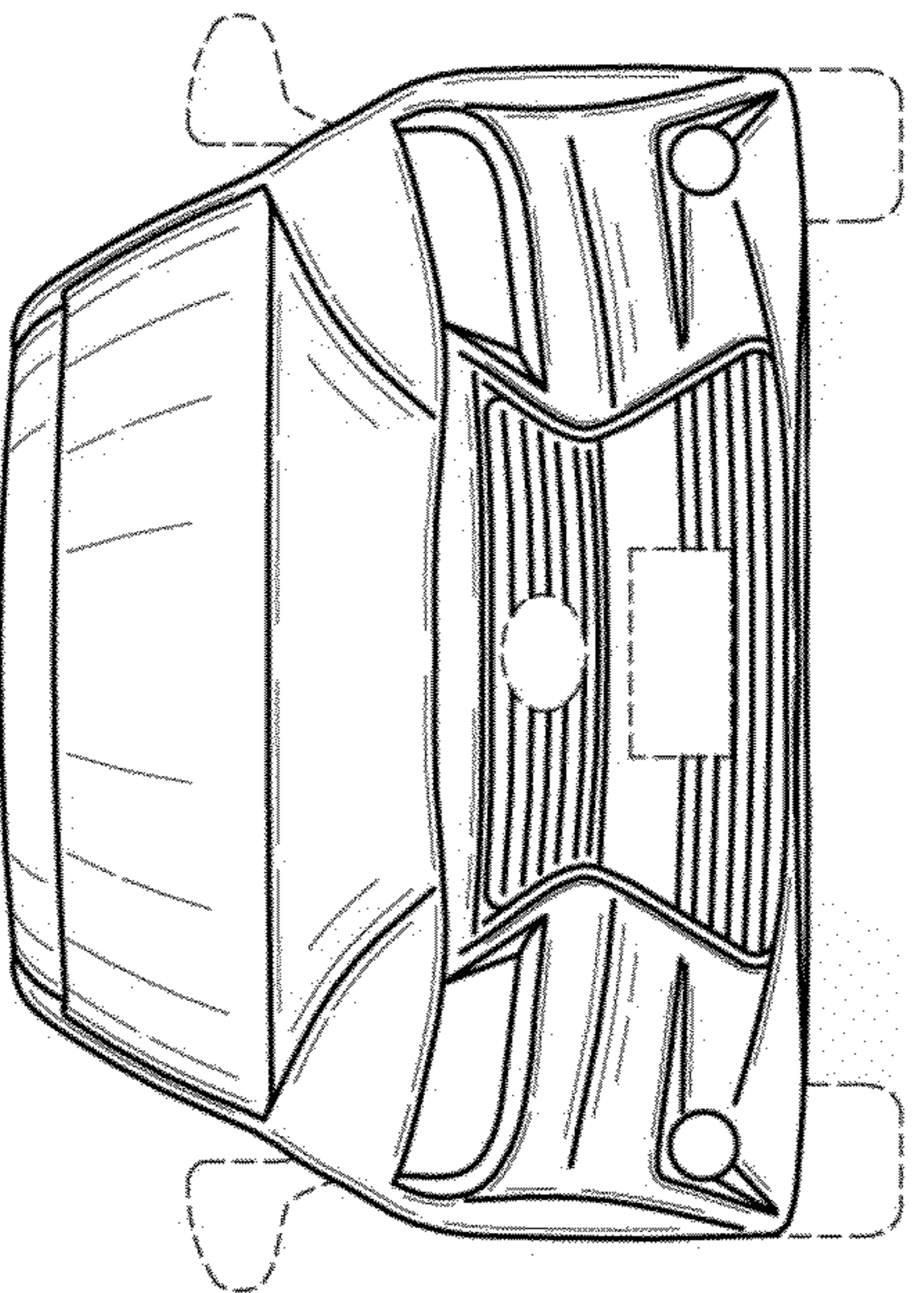

FIG. 4

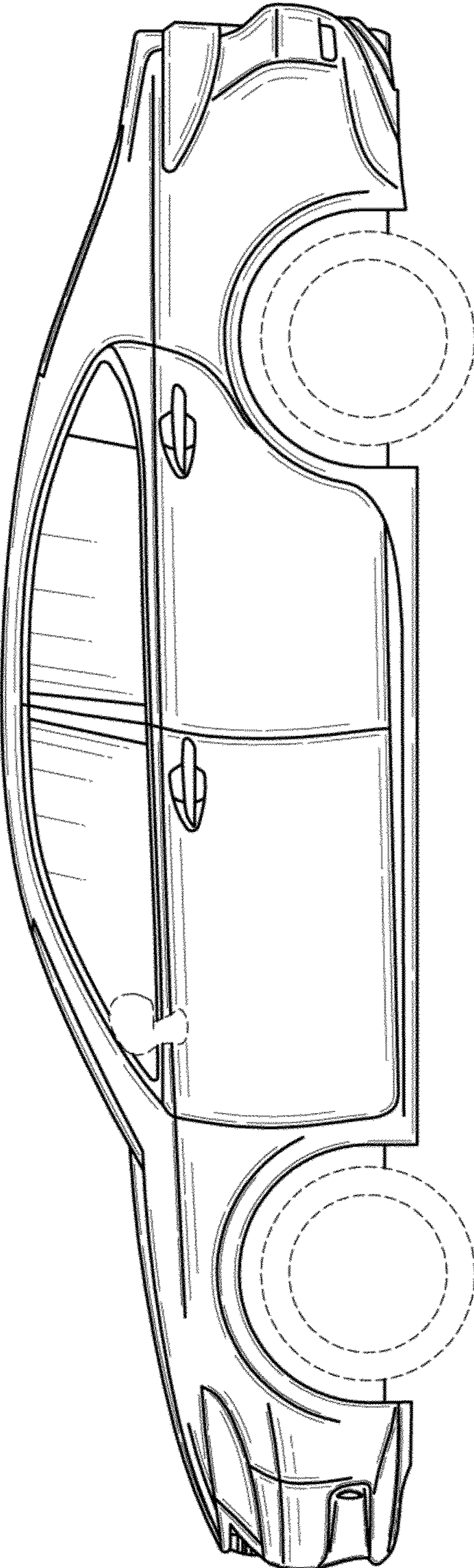

FIG. 5

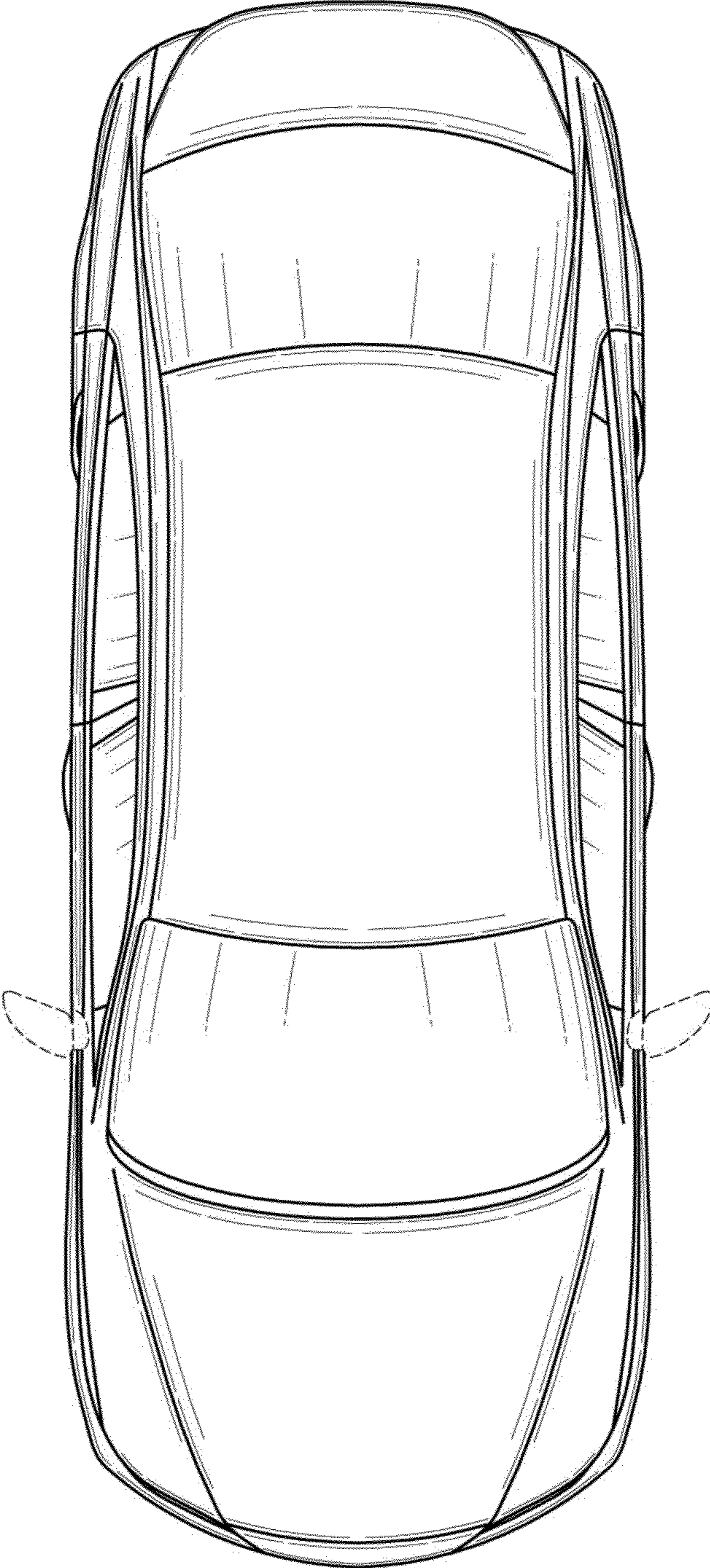

FIG. 6

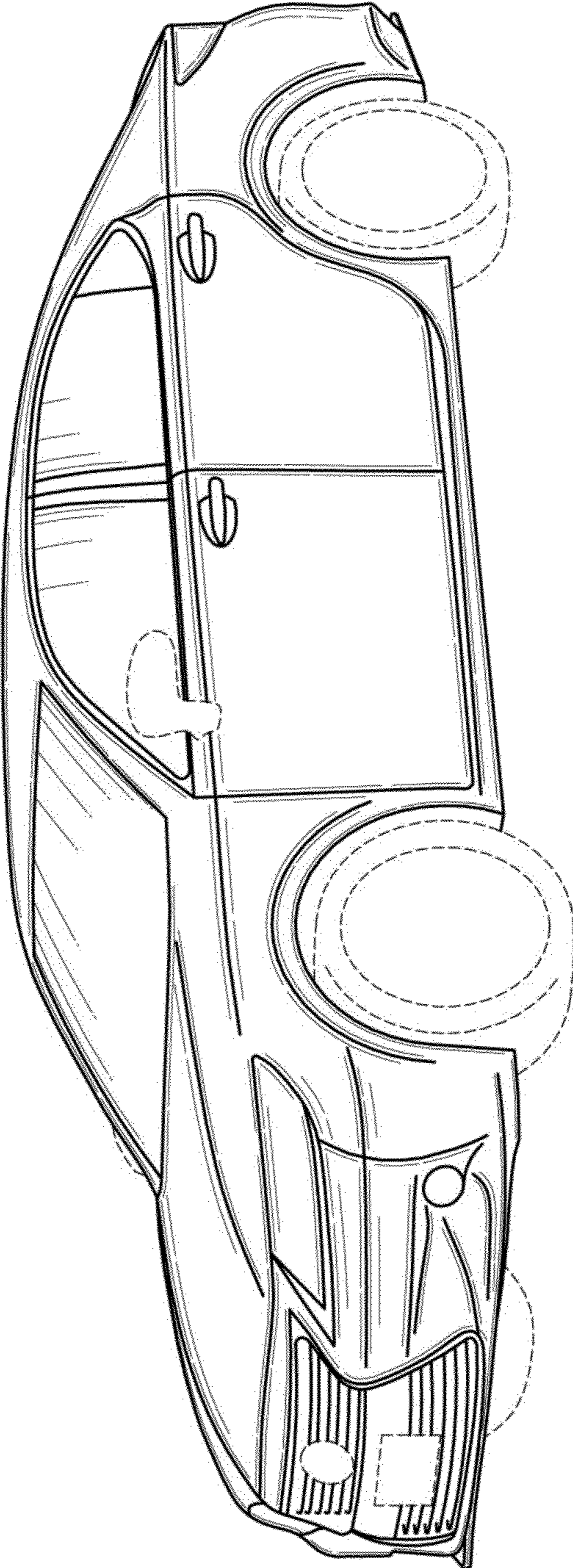

FIG. 7

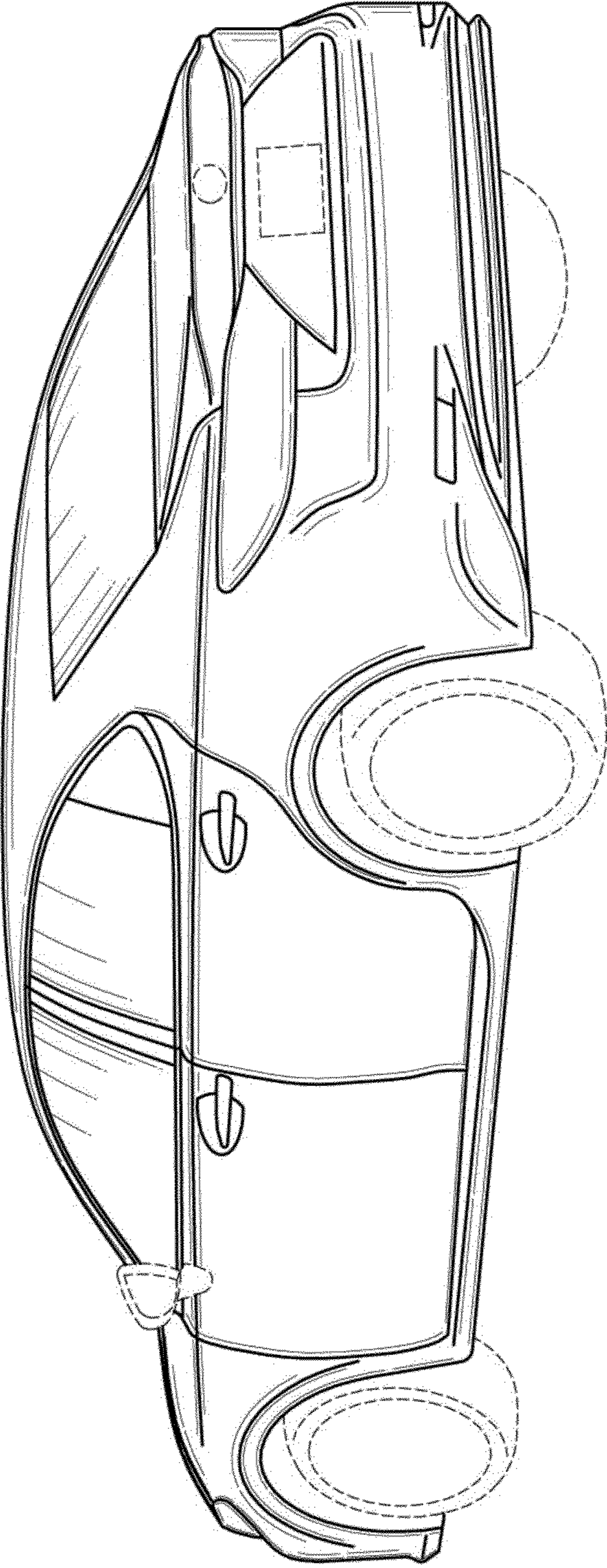

FIG. 8

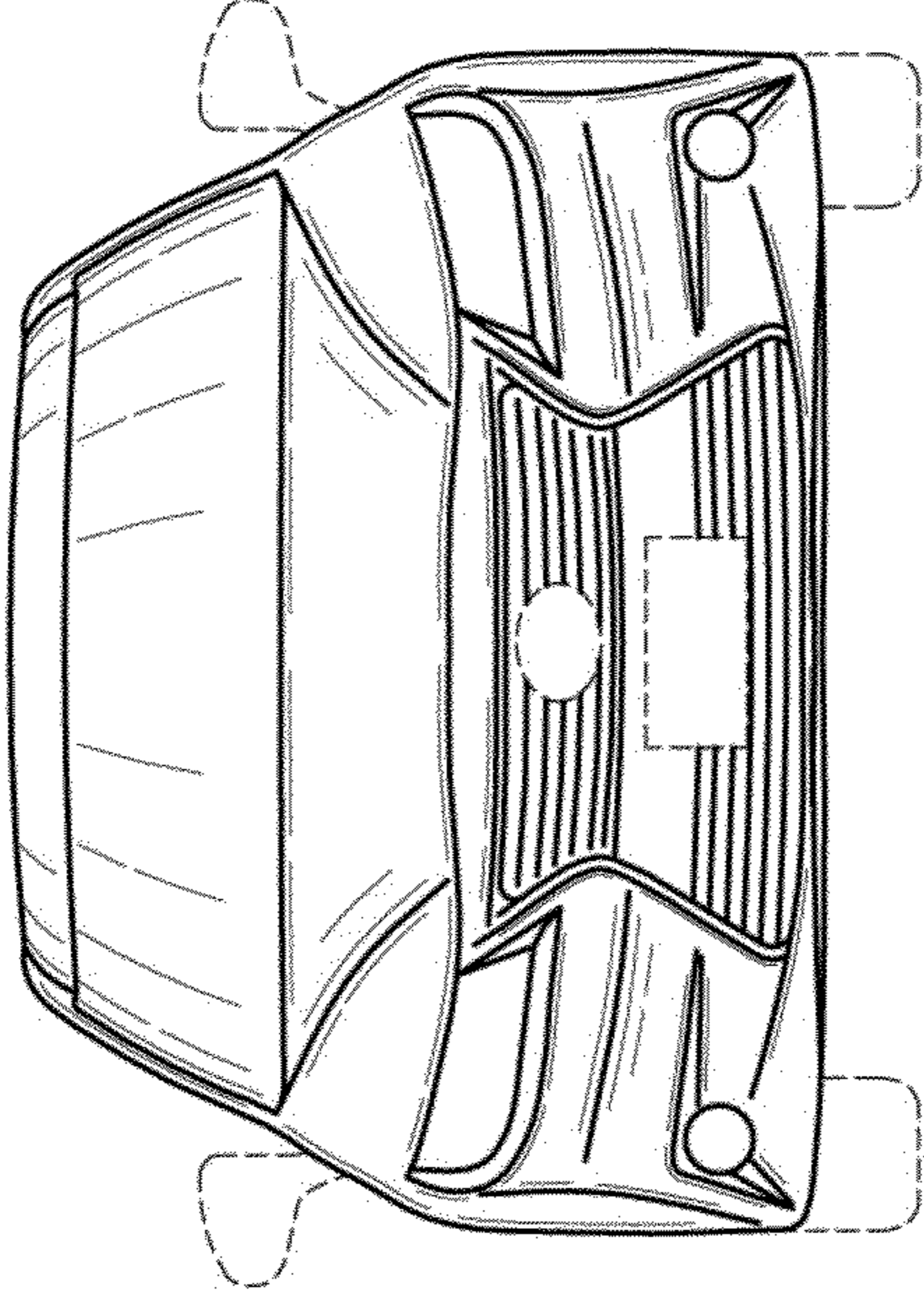

FIG. 9

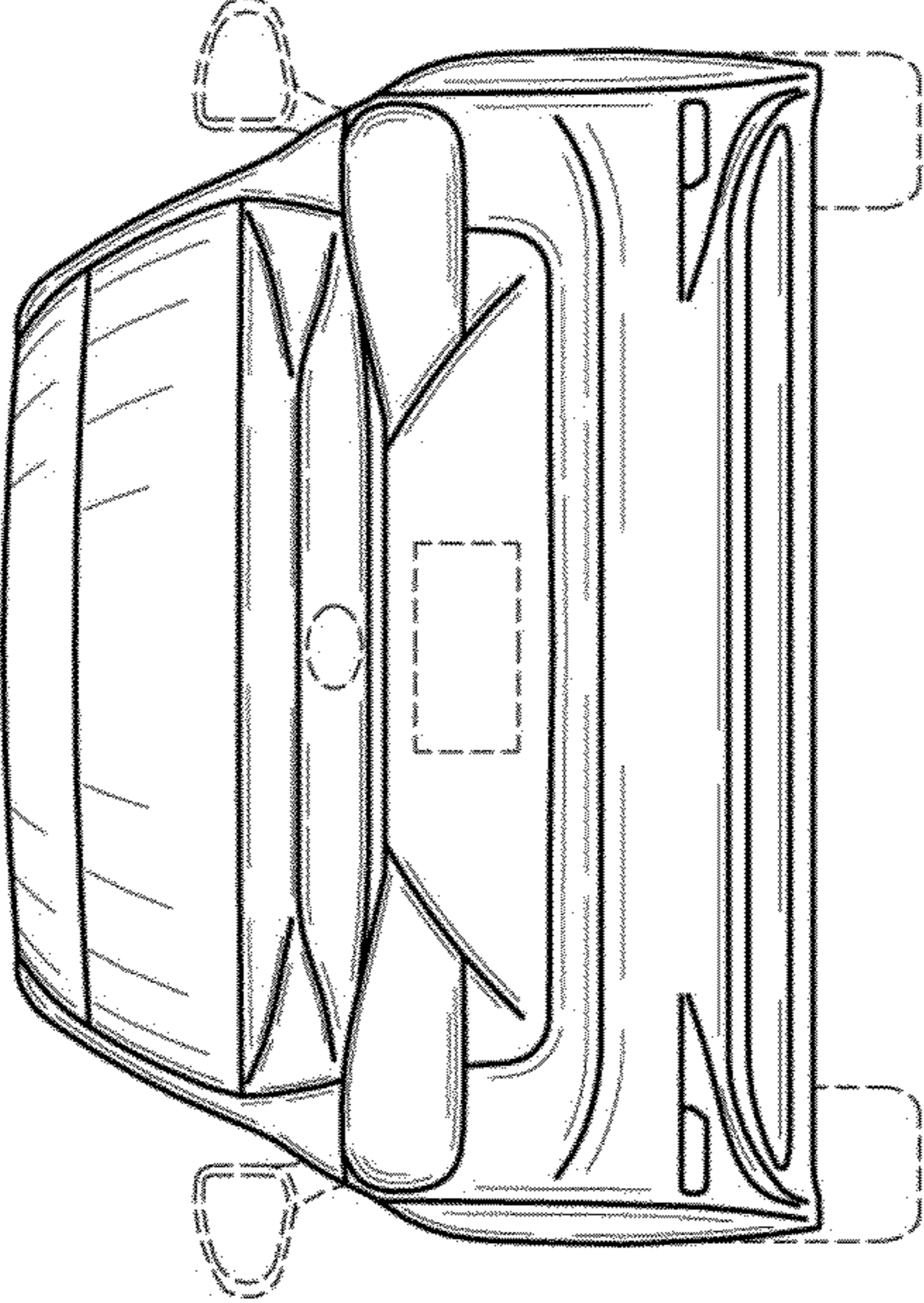

FIG. 10

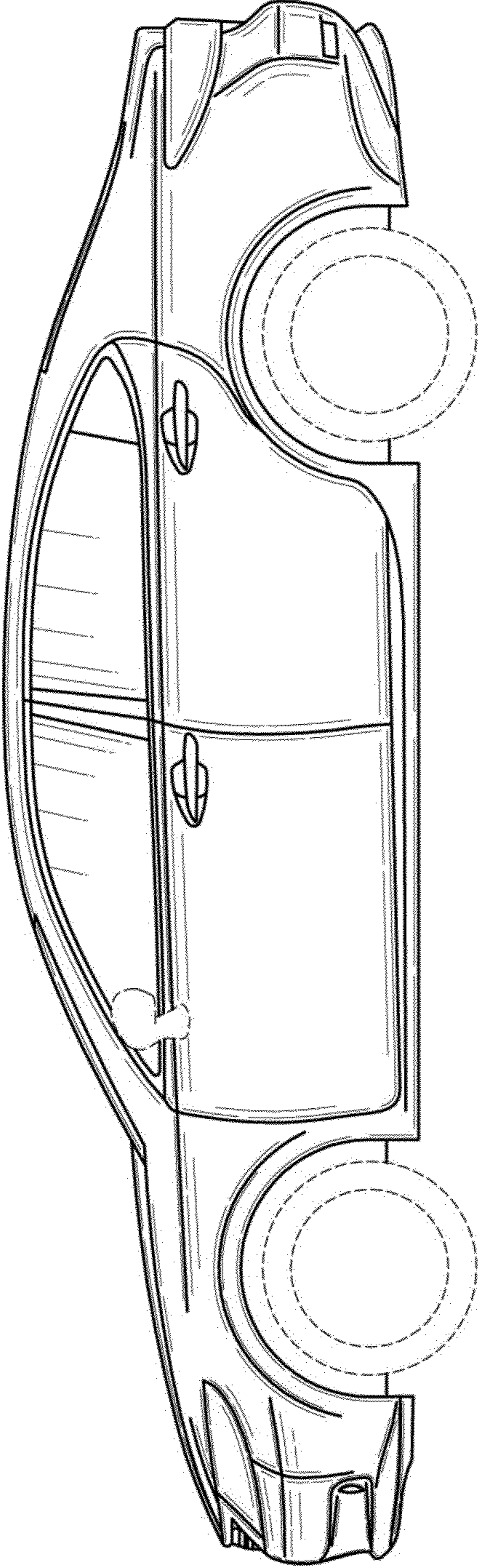

FIG. 11

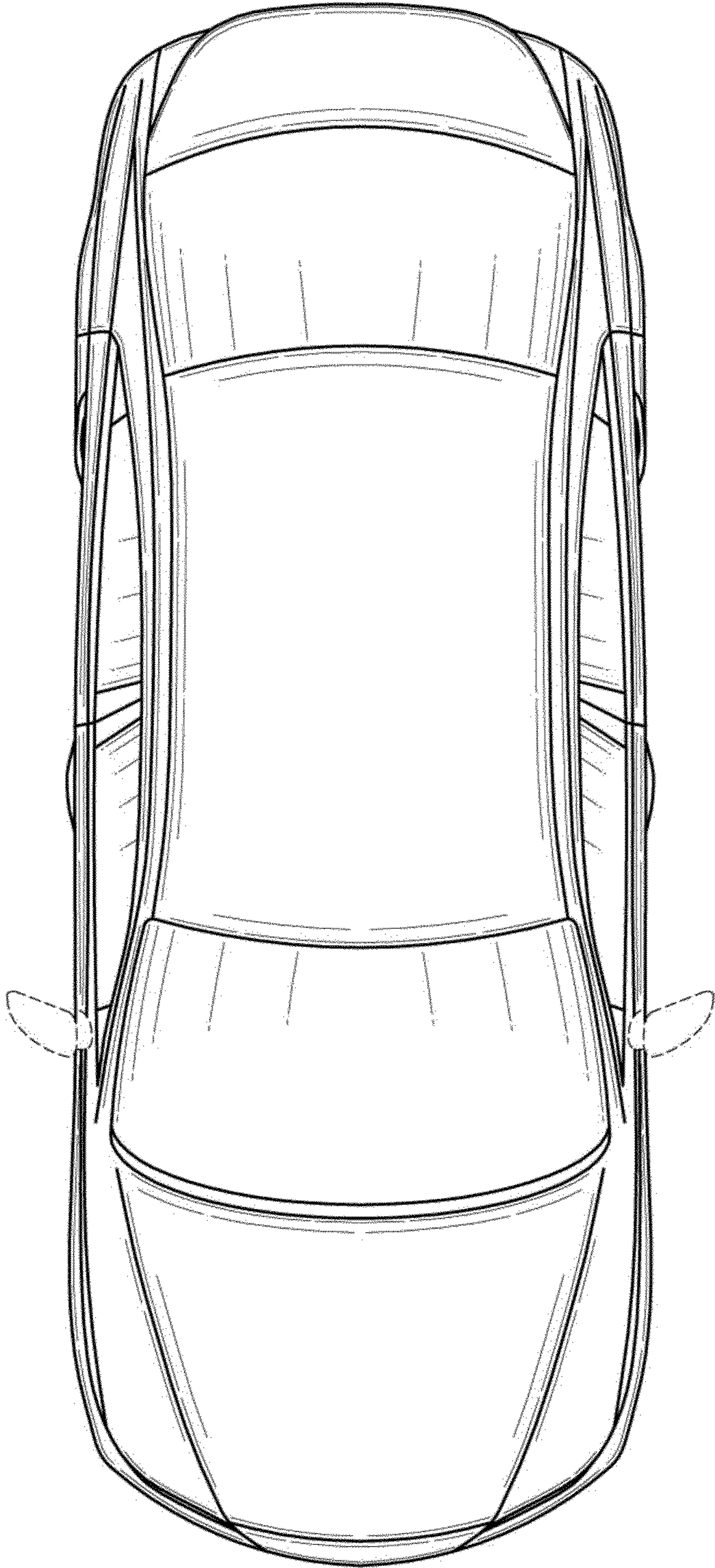

FIG. 12

UNITED STATES PATENT AND TRADEMARK OFFICE
CERTIFICATE OF CORRECTION

PATENT NO. : D691,517 S
APPLICATION NO. : 29/425109
DATED : October 15, 2013
INVENTOR(S) : Pansoo Kwon et al.

Page 1 of 1

It is certified that error appears in the above-identified patent and that said Letters Patent is hereby corrected as shown below:

On the Title Page, Item (75) should read

--(75) Inventors: **Pansoo Kwon, Okazaki-shi (JP); Shinno Kato, Miyoshi-shi (JP);
Yuri Kaneda, Toyota-shi (JP); Yuji Fujiwara, Toyokawa-shi (JP)--**

Signed and Sealed this
Twenty-fourth Day of December, 2013

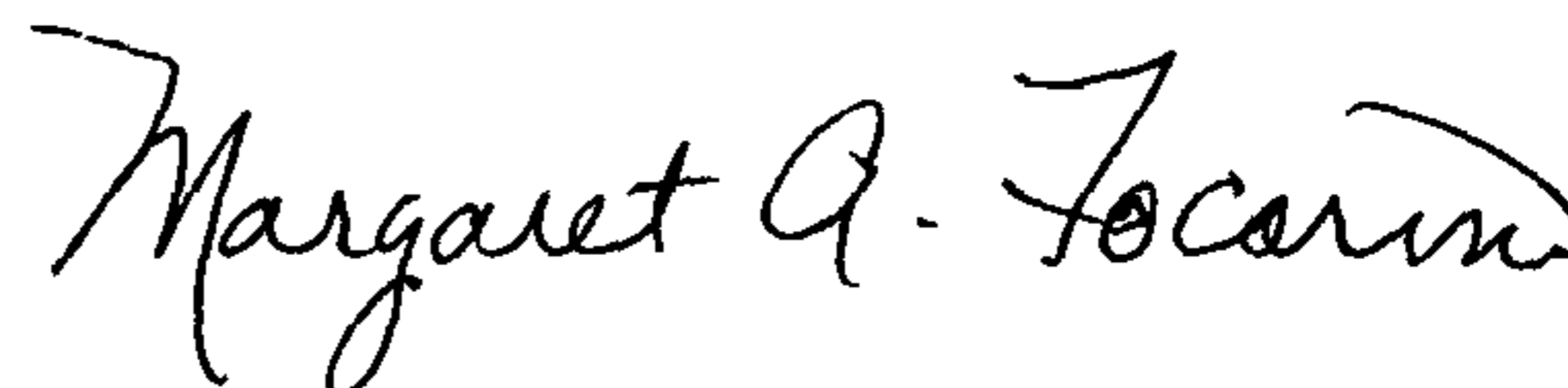

Margaret A. Focarino
Commissioner for Patents of the United States Patent and Trademark Office