

US00D691503S

(12) **United States Design Patent**  
**Betsinger**

(10) **Patent No.:** **US D691,503 S**  
(45) **Date of Patent:** **\*\* Oct. 15, 2013**

(54) **HOSE SENSOR SIGNAL RECEIVER**

(75) Inventor: **James Dean Betsinger**, Waterville, OH  
(US)

(73) Assignee: **Eaton Corporation**, Cleveland, OH  
(US)

(\*\*) Term: **14 Years**

(21) Appl. No.: **29/419,413**

(22) Filed: **Apr. 27, 2012**

(51) **LOC (9) Cl.** ..... **10-04**

(52) **U.S. Cl.**  
USPC ..... **D10/96; D10/101**

(58) **Field of Classification Search**  
USPC ..... D10/96, 101; 73/40, 49.5, 49.1, 49.2,  
73/40.5 R, 763; 137/312; 138/104, 125,  
138/127; 174/11 R; 285/8, 10; 340/438,  
340/605, 604, 618.3; 702/34, 35, 185  
See application file for complete search history.

(56) **References Cited**

U.S. PATENT DOCUMENTS

3,555,887	A	9/1971	Wood	
3,906,340	A *	9/1975	Wingfield et al.	324/682
D336,889	S	6/1993	Boyer	
D363,444	S *	10/1995	Davis	D10/101
5,634,497	A	6/1997	Neto	
5,969,618	A	10/1999	Redmond	
5,992,218	A	11/1999	Tryba	
D424,461	S	5/2000	Taylor	
D444,087	S *	6/2001	Johannsen et al.	D10/81
6,384,728	B1 *	5/2002	Kanor et al.	340/573.1
6,386,237	B1	5/2002	Chevalier et al.	
D464,031	S	10/2002	Gillingham	
6,498,991	B1	12/2002	Phelan et al.	
6,573,837	B2 *	6/2003	Bluteau	340/604
7,049,969	B2 *	5/2006	Tamai	340/573.5
7,119,699	B2 *	10/2006	King et al.	340/618
7,151,458	B2 *	12/2006	Randolph	340/573.5

D557,657	S	12/2007	Yabe et al.	
D575,280	S	8/2008	Marquez	
D576,901	S	9/2008	Fraser et al.	
7,555,936	B2	7/2009	Deckard	
7,948,388	B2 *	5/2011	McGinty et al.	340/605
8,106,781	B2 *	1/2012	Pietersen	340/573.1
D673,545	S *	1/2013	Magness et al.	D14/250

OTHER PUBLICATIONS

Eaton Corporation Brochure—Lifesense Hydraulic Hose Condition Monitoring 3 Pages, Document No. E-HOOV-MR011-E, Printed in USA, Mar. 2011.

\* cited by examiner

*Primary Examiner* — Antoine D Davis

(74) *Attorney, Agent, or Firm* — Jarett D. Millar

(57) **CLAIM**

The ornamental design for a hose sensor signal receiver, as shown and described.

**DESCRIPTION**

FIG. 1 is a perspective view of a hose sensor signal receiver showing my new design.

FIG. 2 is a top plan view of the hose sensor signal receiver of FIG. 1.

FIG. 3 is a bottom plan view of the hose sensor signal receiver of FIG. 1.

FIG. 4 is a left elevation view of the hose sensor signal receiver of FIG. 1.

FIG. 5 is a right elevation view of the hose sensor signal receiver of FIG. 1.

FIG. 6 is a back elevation view of the hose sensor signal receiver of FIG. 1; and,

FIG. 7 is a front elevation view of the hose sensor signal receiver of FIG. 1.

The broken lines illustrate portions of the hose sensor signal receiver which form no part of the claimed design.

**1 Claim, 6 Drawing Sheets**

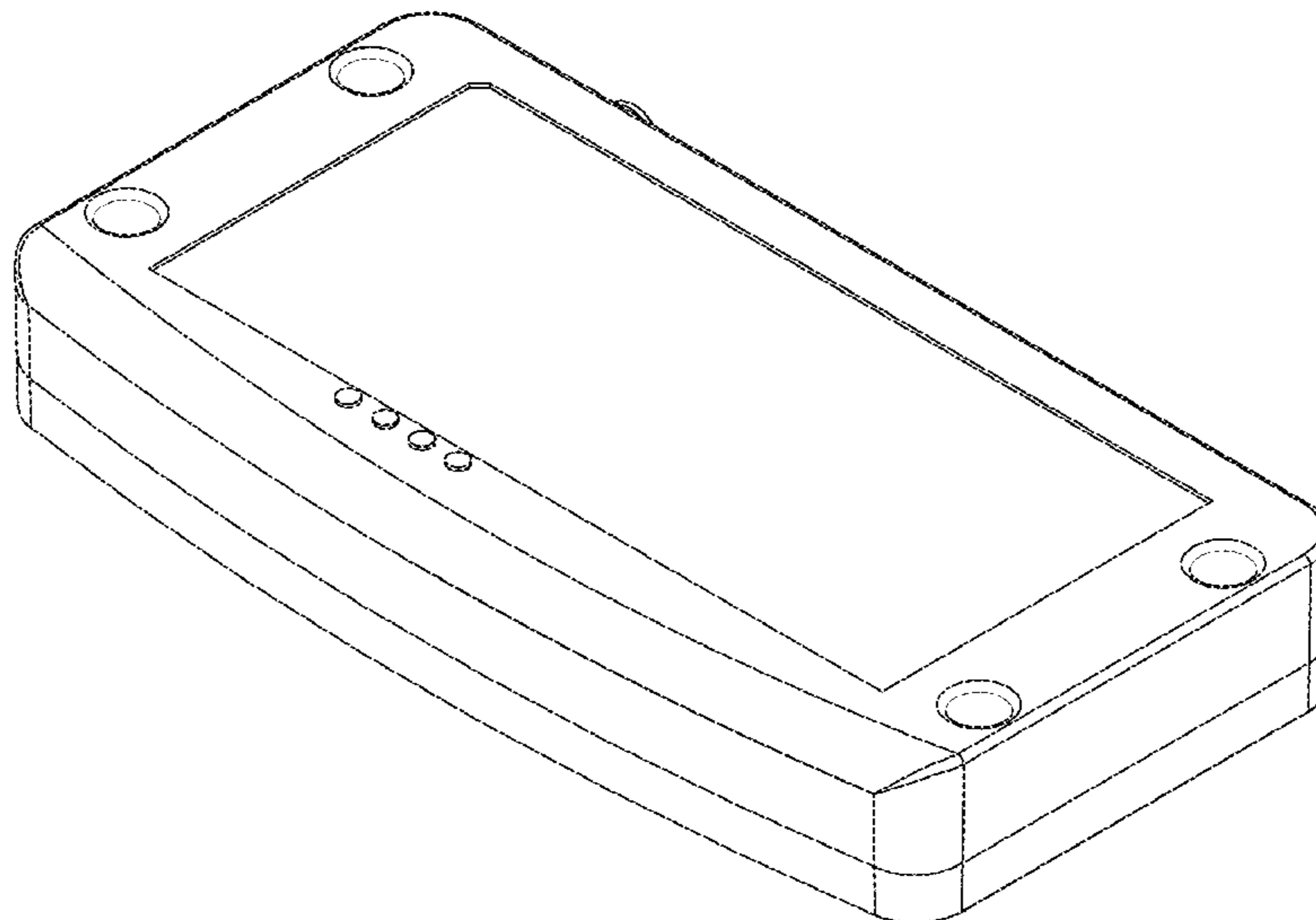

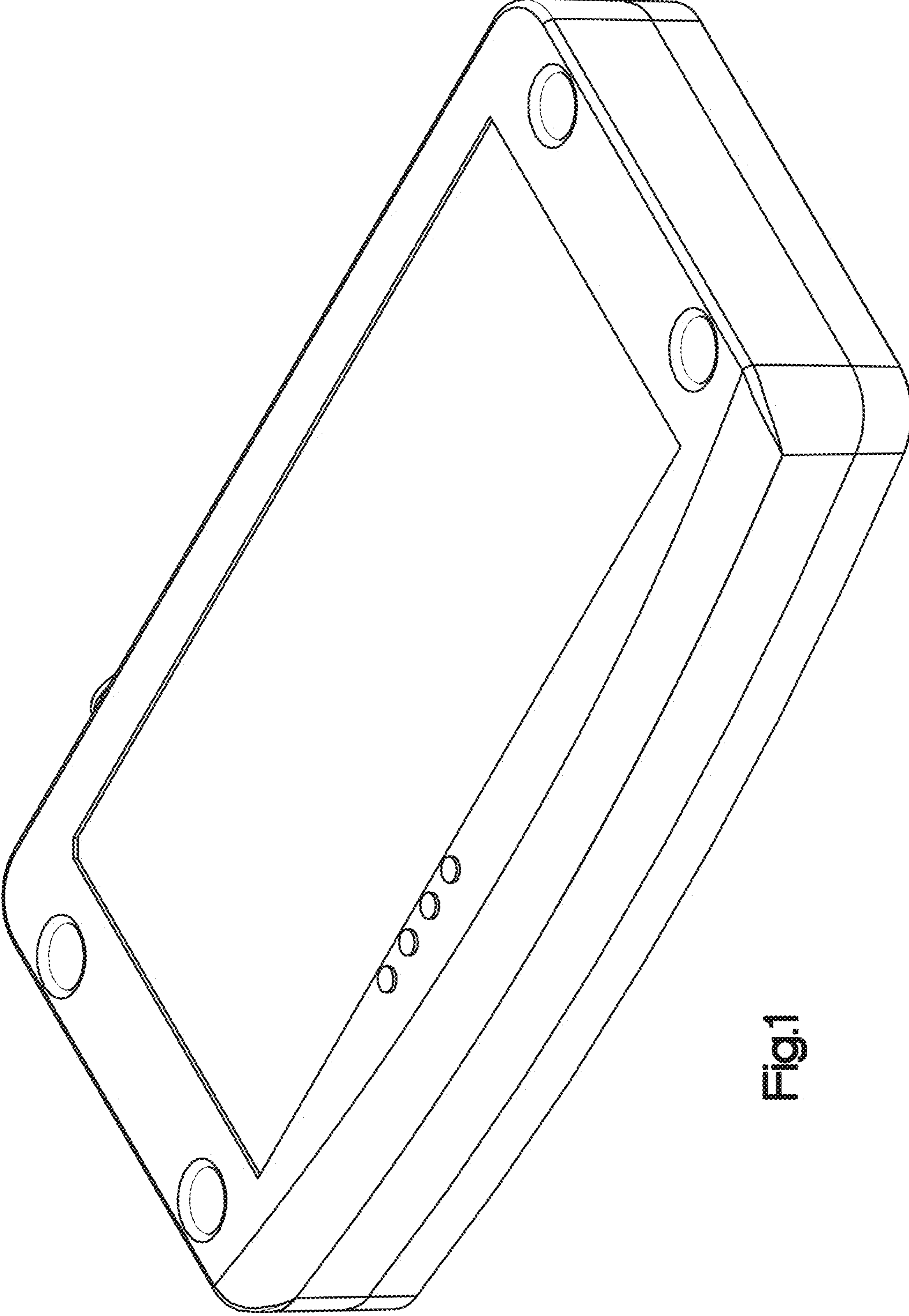

Fig.1

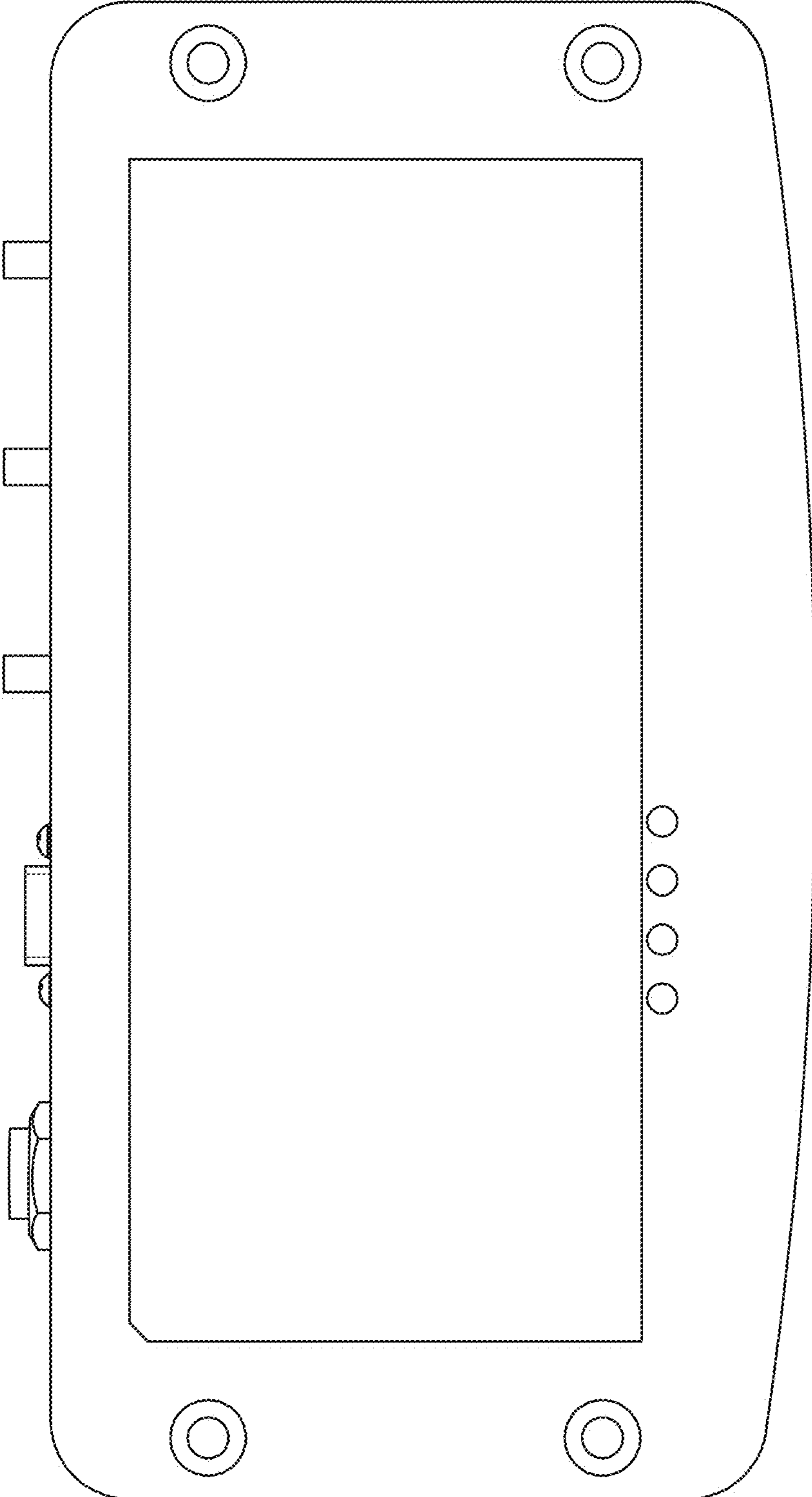

Fig.2

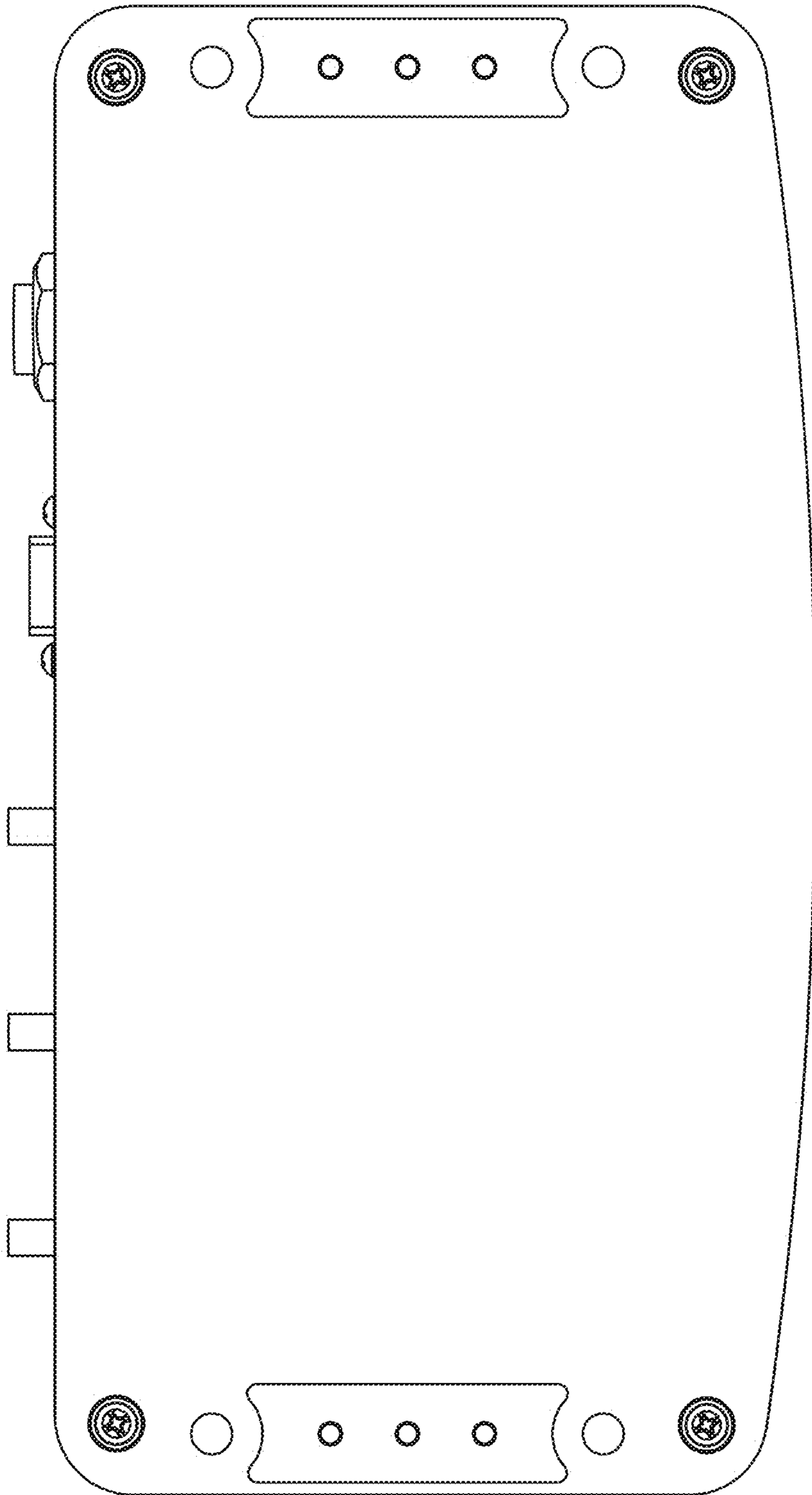

Fig.3

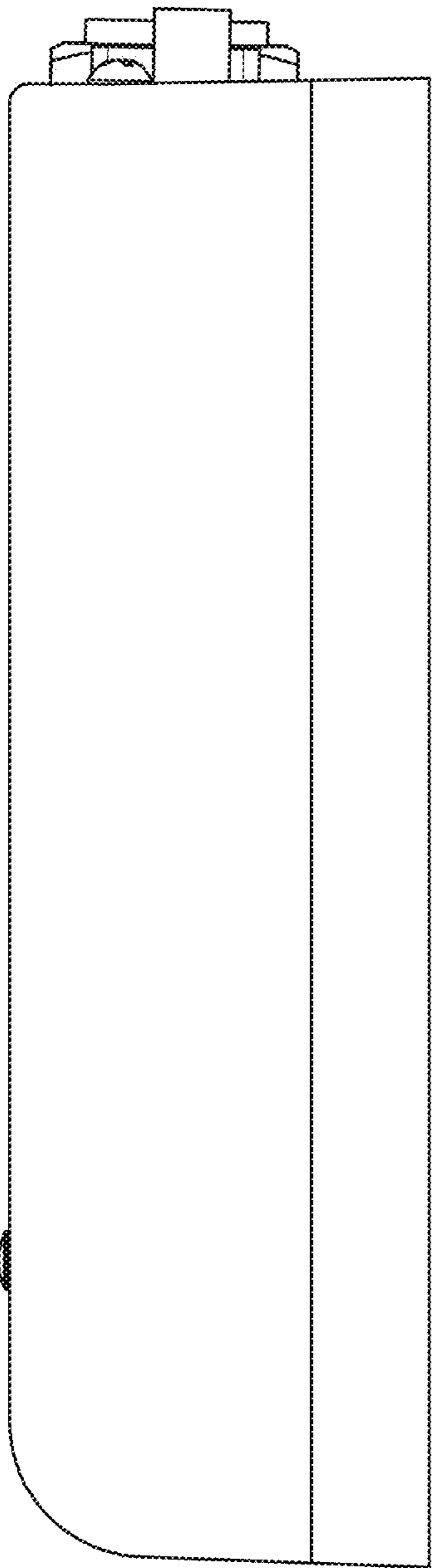

Fig.4

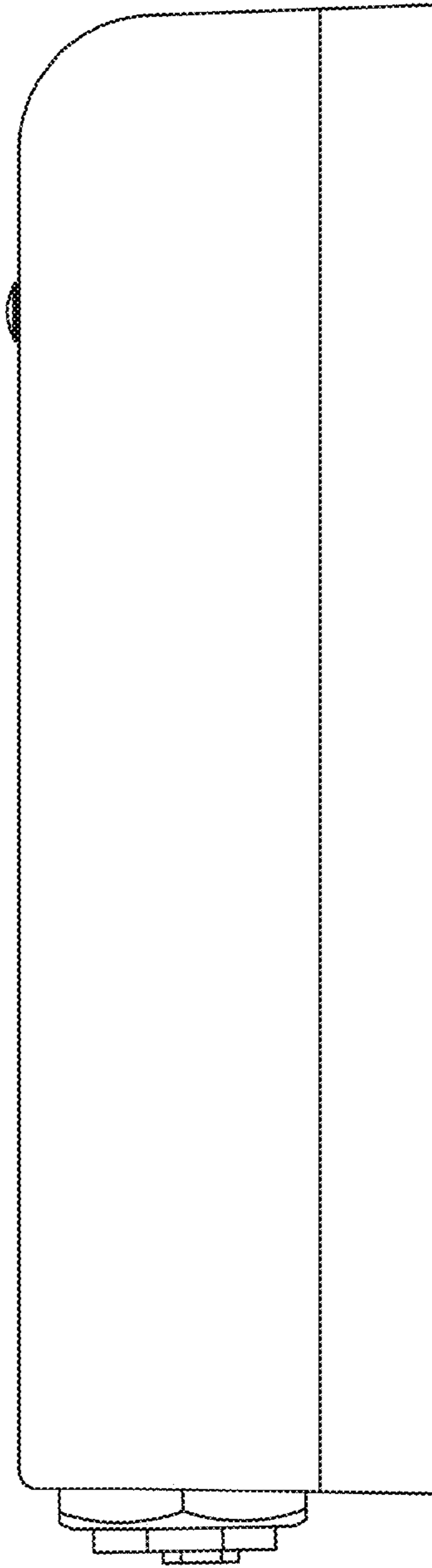

Fig.5

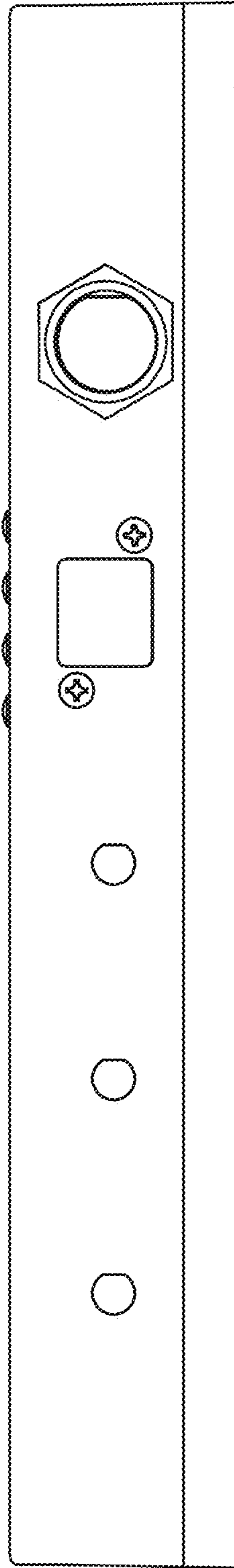

Fig.6



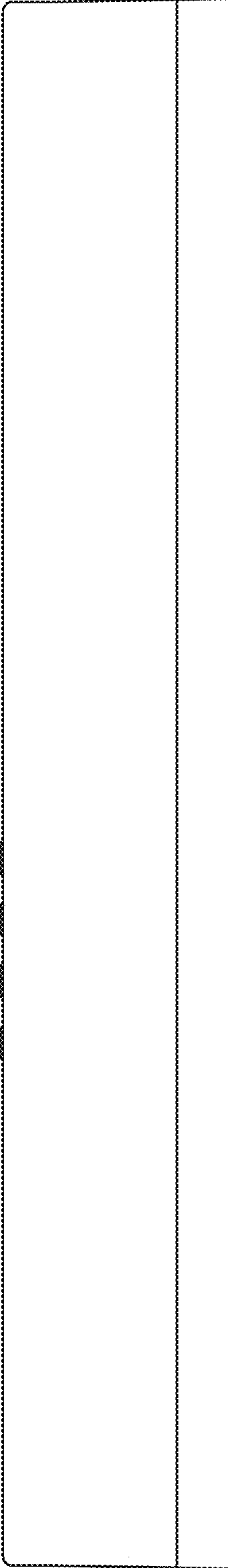

Fig.7