



US00D691350S

(12) **United States Design Patent**
Pearson

(10) **Patent No.:** **US D691,350 S**
(45) **Date of Patent:** **** Oct. 15, 2013**

- (54) **PONYTAIL ACCESSIBLE RAILROAD HAT**
- (76) Inventor: **Laura T. Pearson**, Kemmerer, WY (US)
- (**) Term: **14 Years**
- (21) Appl. No.: **29/416,569**
- (22) Filed: **Mar. 23, 2012**

Related U.S. Application Data

- (63) Continuation-in-part of application No. 29/397,939, filed on Jul. 22, 2011, now abandoned.
 - (51) **LOC (9) Cl.** **02-03**
 - (52) **U.S. Cl.**
USPC **D2/882**
 - (58) **Field of Classification Search**
USPC D2/865, 866, 878, 879, 880, 881, 882, D2/883, 884, 886, 891, 892, 893, 894, D2/895; 2/10, 12, 68, 171, 175.1, 175.2, 2/175.3, 183, 195.1, 195.2, 195.3, 195.4, 2/195.5, 195.6, 200.1, 200.2, 209.11, 2/209.12, 209.13
- See application file for complete search history.

References Cited

U.S. PATENT DOCUMENTS

D19,445 S *	11/1889	Brigham	D2/894
1,435,221 A *	11/1922	Fischer	2/195.4
1,824,840 A *	9/1931	Ruffing, Sr.	2/7
2,007,821 A	7/1935	Uriwal		
2,133,619 A *	10/1938	Hutton	2/172
D117,534 S *	11/1939	Simon	D2/888
2,416,062 A	2/1947	Mercer		
4,179,753 A	12/1979	Aronberg et al.		
4,993,081 A *	2/1991	Fulghum	2/209.12
D324,193 S	2/1992	Wen-Long		
D350,221 S *	9/1994	Van Doren	D2/866
D360,519 S *	7/1995	Bailey	D2/876
5,509,145 A	4/1996	Stevenson et al.		

5,511,249 A	4/1996	Higgins
D374,114 S	10/1996	Arroyo et al.
D374,548 S	10/1996	Hartland
D390,687 S	2/1998	Kazel
5,799,334 A	9/1998	Griffith et al.
5,860,167 A	1/1999	Lizio
D405,590 S	2/1999	Bartz
5,933,872 A	8/1999	Lema
D416,666 S	11/1999	Ballew
5,987,648 A	11/1999	Boyd
D425,688 S	5/2000	Richlin
D427,751 S	7/2000	Richlin
6,237,159 B1	5/2001	Martin
D456,118 S	4/2002	Hill
D482,186 S	11/2003	Pytanowski et al.
6,647,554 B1	11/2003	Yan

(Continued)

OTHER PUBLICATIONS

“Michigan-Made Monday: Stormy Kromer Hats,” [on-line]; [posted to the Internet on Feb. 21, 2011 by Angela Wisniewski]; [retrieved from the Internet on Jun. 8, 2013]. URL: >http://www.heyangela.com/2011/02/21/michigan-made-monday-stormy-kromer-hats/<. (2 pages).*

Primary Examiner — Karen E Eldridge Powers

(57) **CLAIM**

The ornamental design for a ponytail accessible railroad hat, as shown and described.

DESCRIPTION

FIG. 1 is a side elevation view of a ponytail accessible railroad hat showing my new design;
FIG. 2 is a back elevation view thereof;
FIG. 3 is a front elevation view thereof;
FIG. 4 is a top plan view thereof;
FIG. 5 is a bottom plan view thereof;
FIG. 6 is a front perspective view thereof; and,
FIG. 7 is back perspective view thereof.

1 Claim, 6 Drawing Sheets

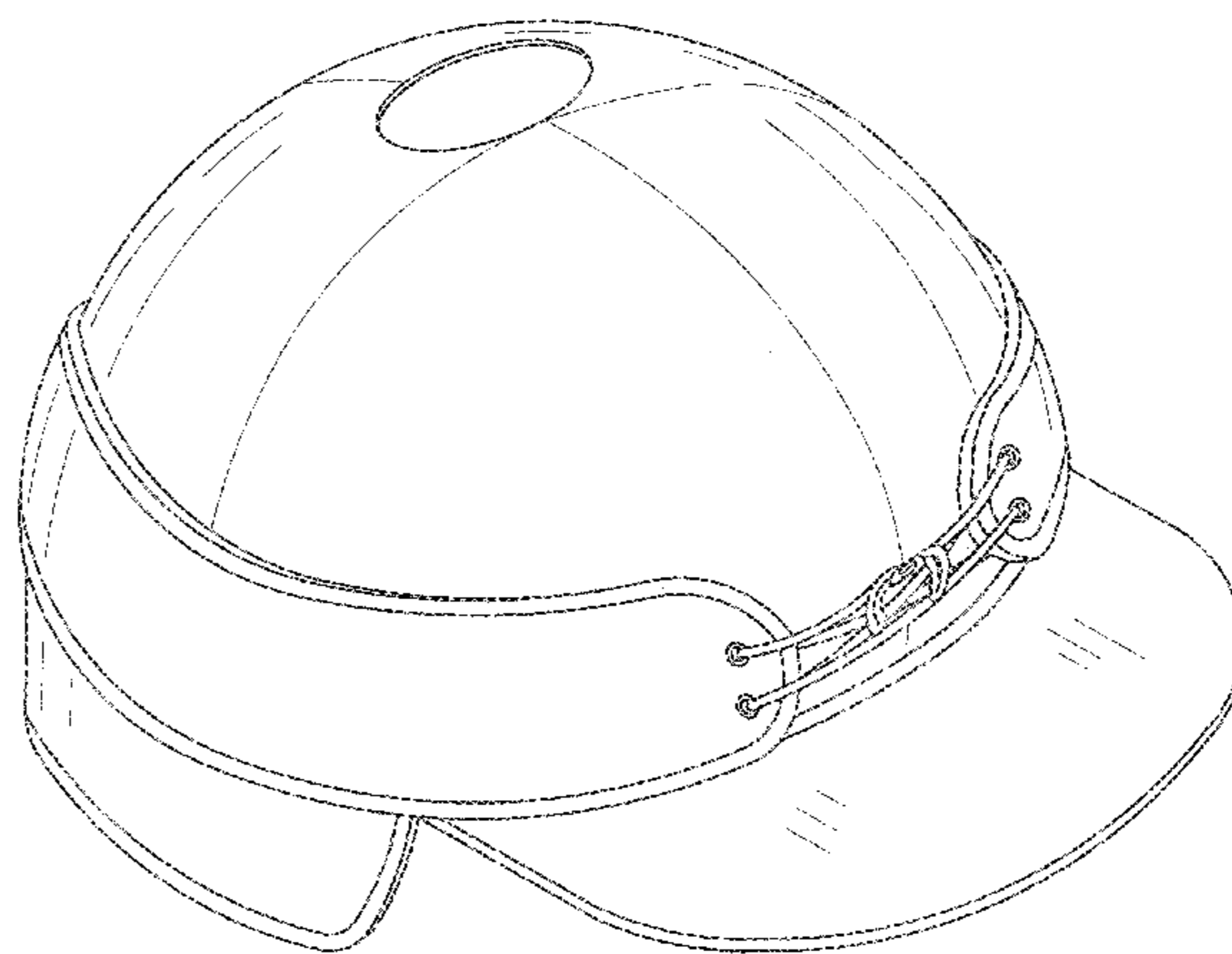
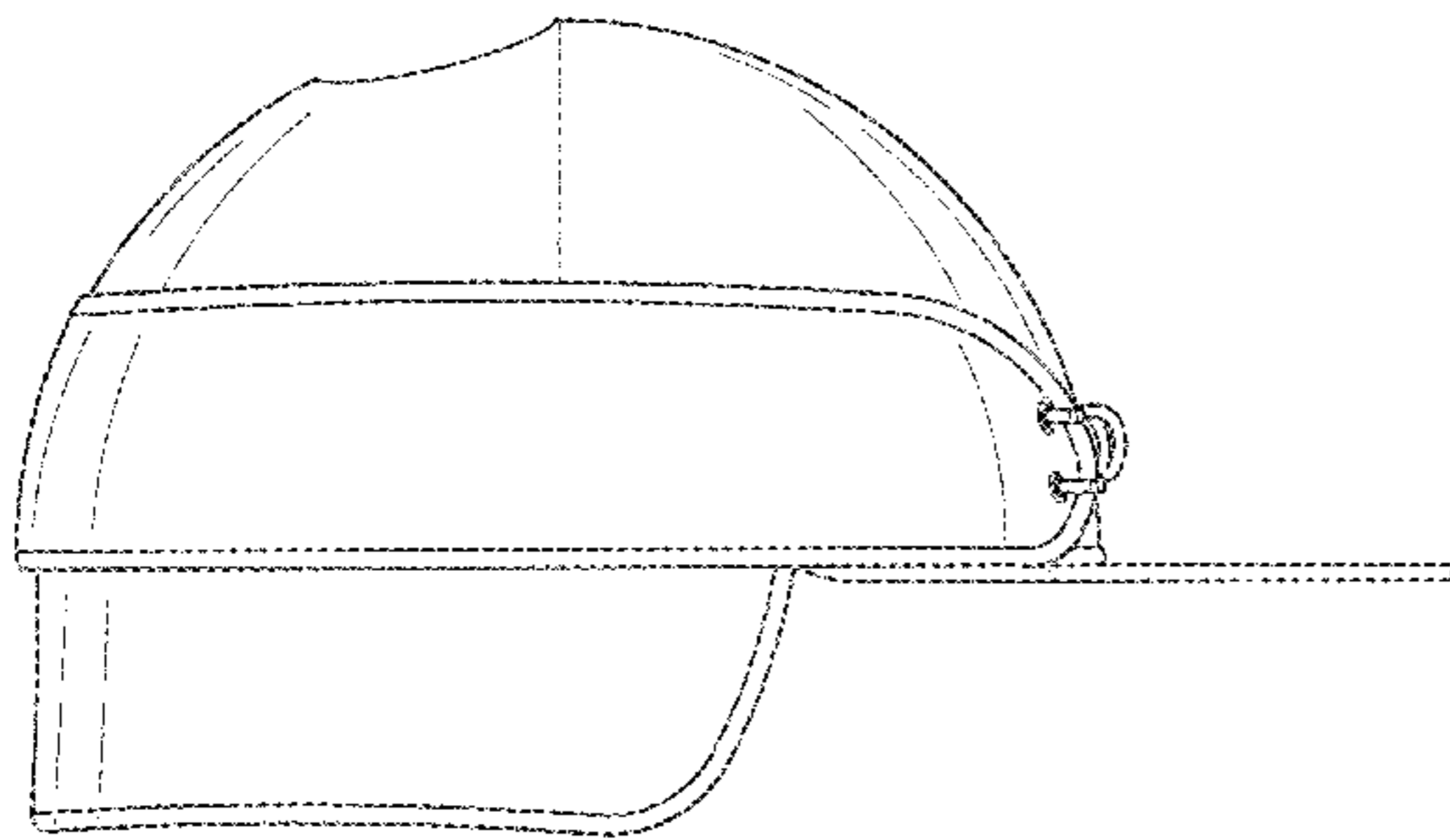

(56)

References Cited

U.S. PATENT DOCUMENTS

D486,623 S	2/2004	Mansell et al.					
6,711,749 B2	3/2004	White et al.					
D489,165 S	5/2004	Waters					
D493,605 S	8/2004	Gilmore					
D496,146 S	9/2004	Appleberry					
D503,261 S	3/2005	Pedersen					
D517,778 S	3/2006	Steichen					
7,062,793 B2	6/2006	Liao					
7,107,625 B2	9/2006	St-Germain					
D532,185 S	11/2006	St-Germain					
D538,010 S	3/2007	Pegula					
D541,013 S *	4/2007	Kim	D2/882				
D541,509 S	5/2007	Sprowl					
D546,031 S *	7/2007	Pearson et al.	D2/876				
D558,432 S *	1/2008	Kim	D2/882				
				D571,981 S *	7/2008	Free	D2/872
				7,454,799 B2	11/2008	Wuensch et al.	
				D590,136 S	4/2009	Campos et al.	
				D593,732 S	6/2009	Tilley et al.	
				D613,040 S	4/2010	Pearson	
				D617,537 S	6/2010	Pearson	
				8,141,395 B2 *	3/2012	Dillavou	66/171
				2002/0095715 A1	7/2002	Hong	
				2003/0135912 A1	7/2003	White et al.	
				2003/0233696 A1	12/2003	Lee	
				2004/0128740 A1	7/2004	Hoyez	
				2004/0187191 A1	9/2004	Lee	
				2005/0066421 A1 *	3/2005	Brundage	2/209.3
				2006/0230498 A1 *	10/2006	Yan	2/209.12
				2007/0220656 A1	9/2007	Cotutsca	
				2007/0250987 A1 *	11/2007	Adkins	2/209.3
				2008/0098502 A1 *	5/2008	Tai	2/175.1
				2008/0163405 A1 *	7/2008	Jacquart et al.	2/172

* cited by examiner

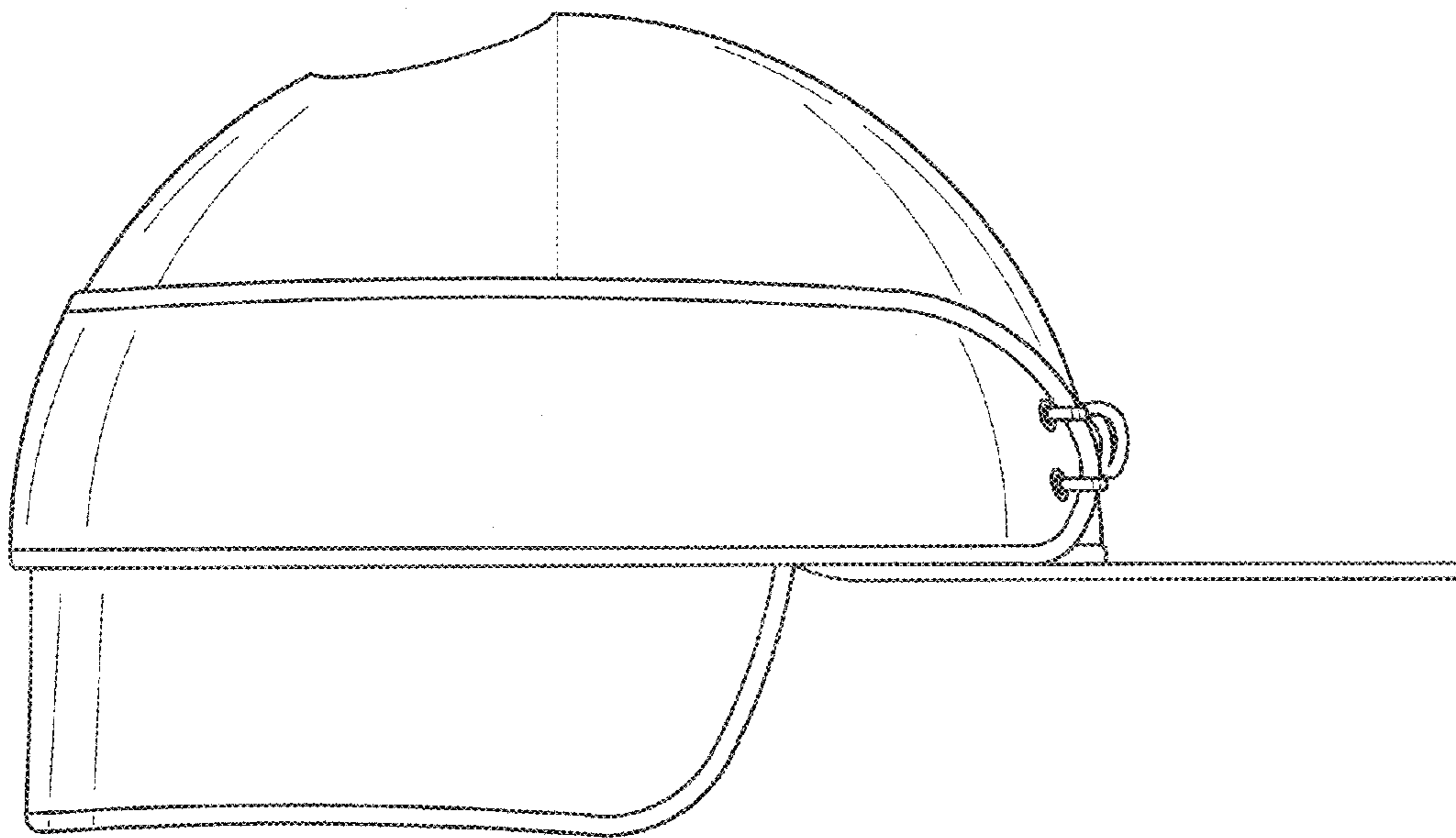

FIG. 1

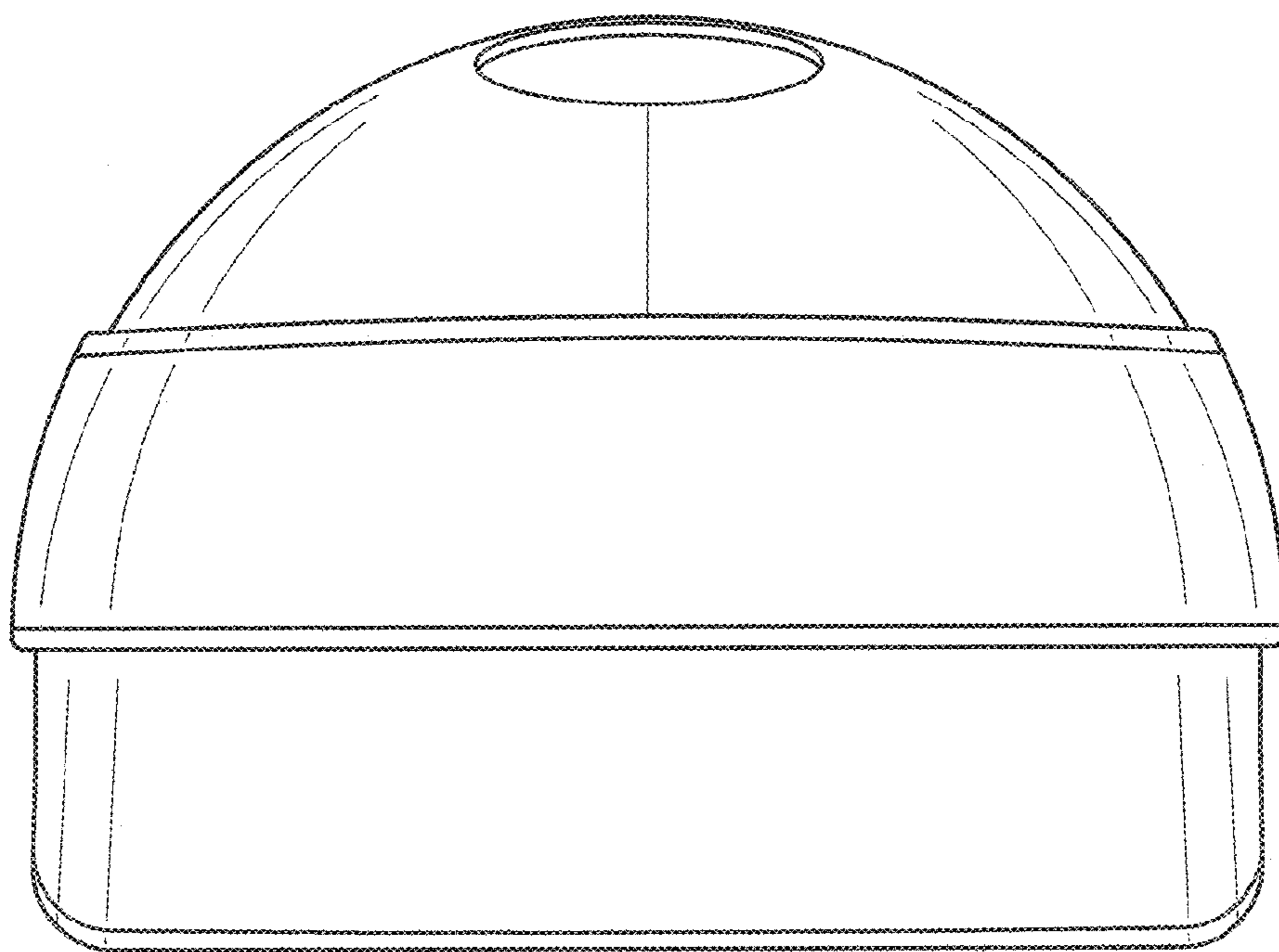

FIG. 2

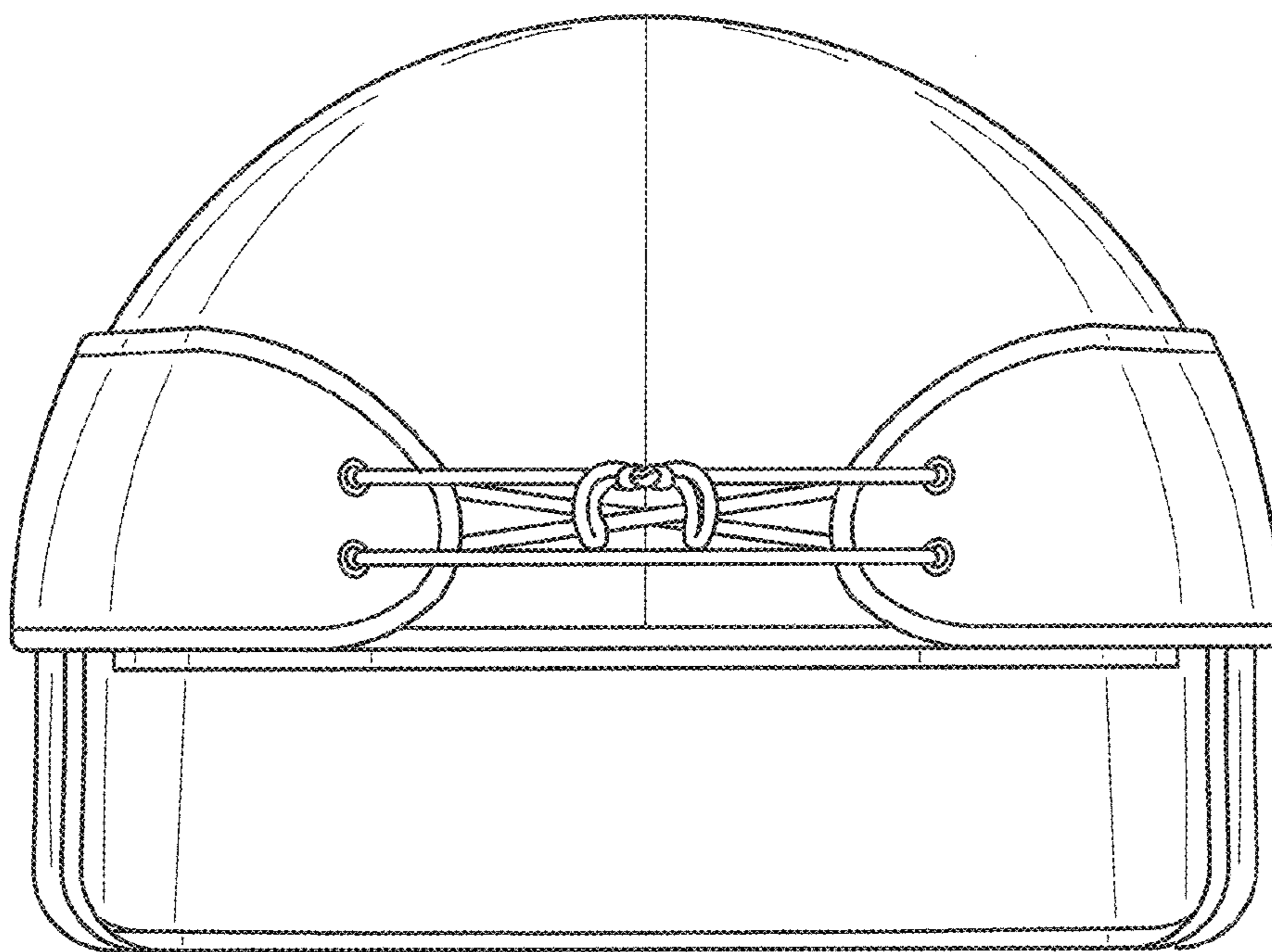

FIG. 3

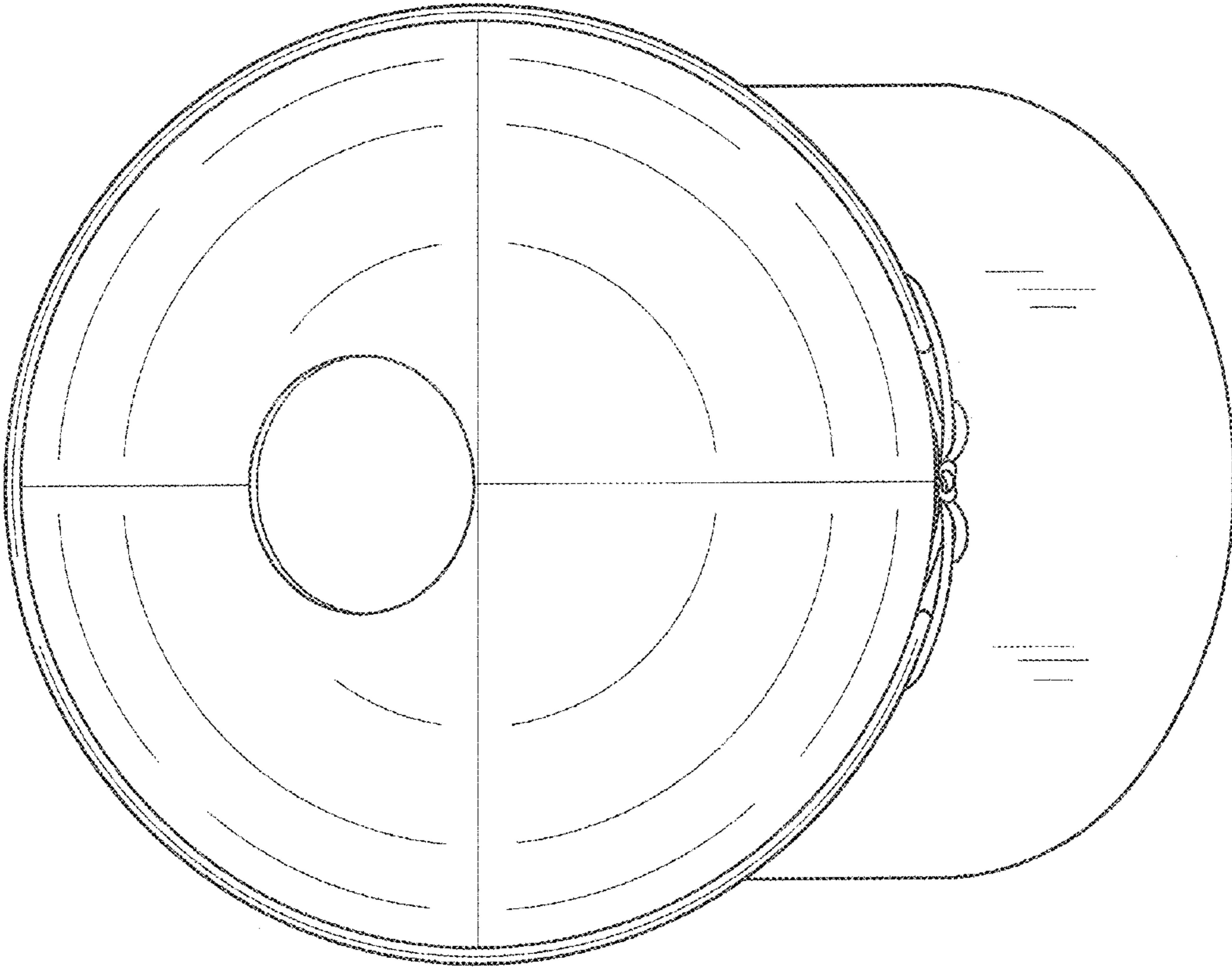

FIG. 4

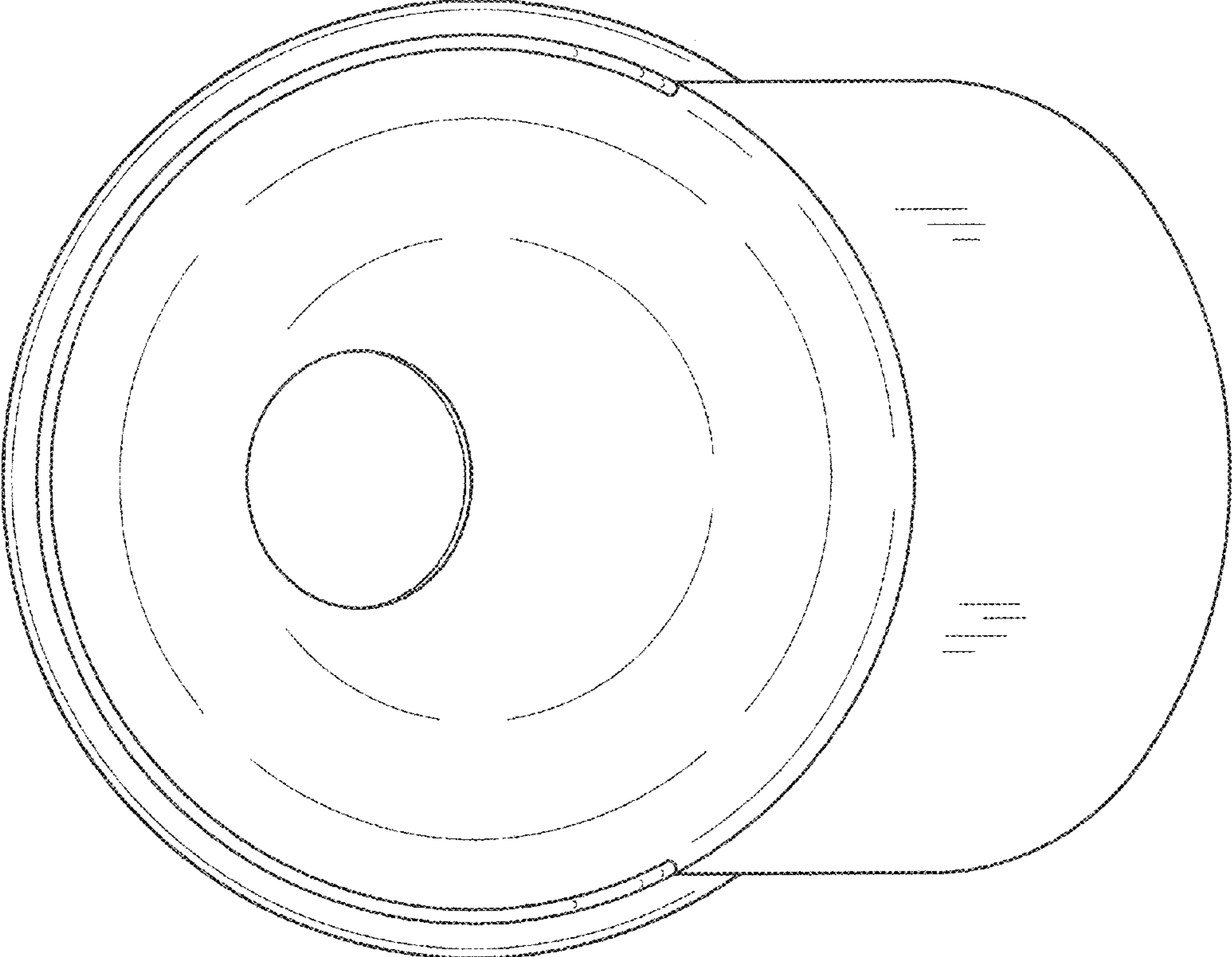

FIG. 5

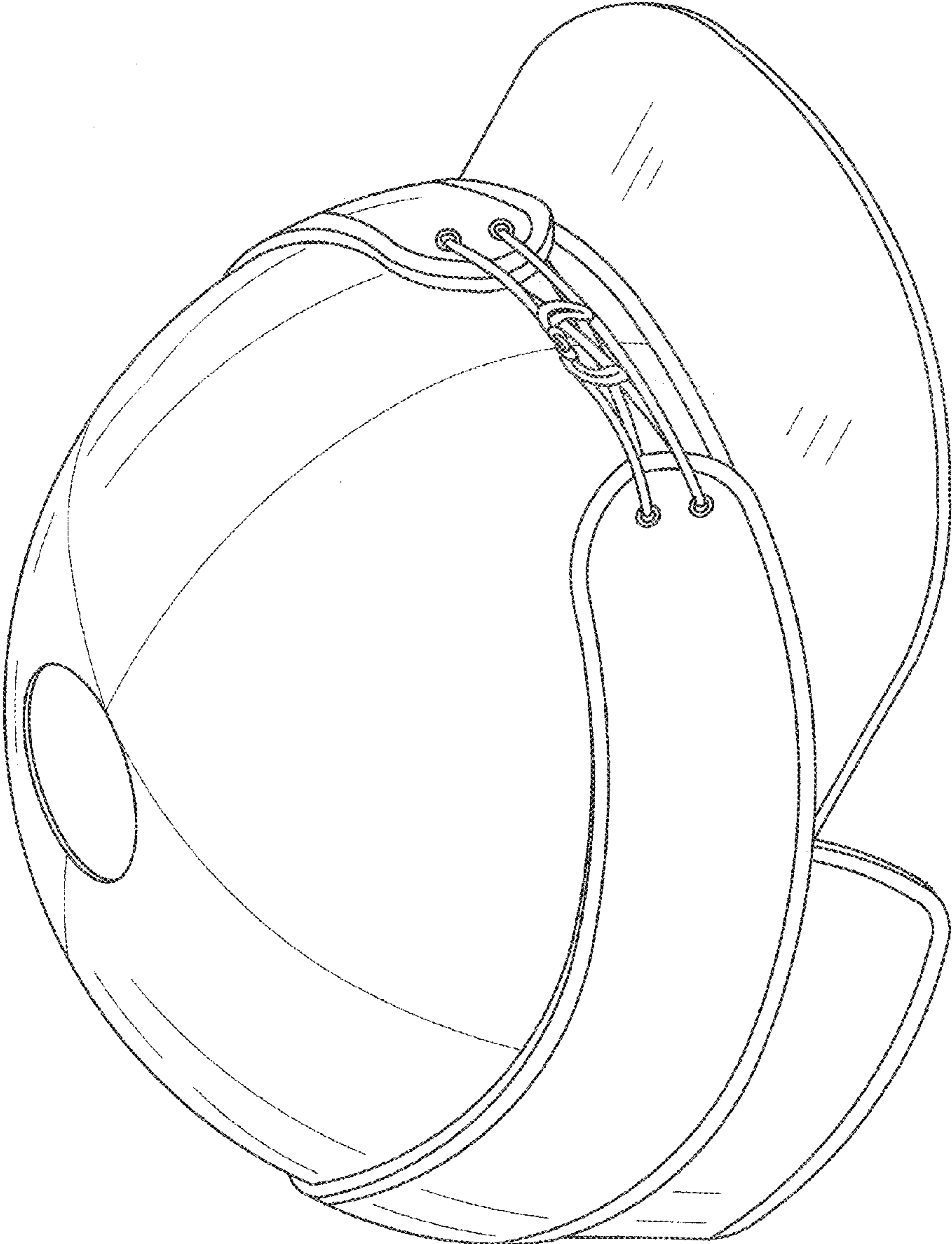

FIG. 6

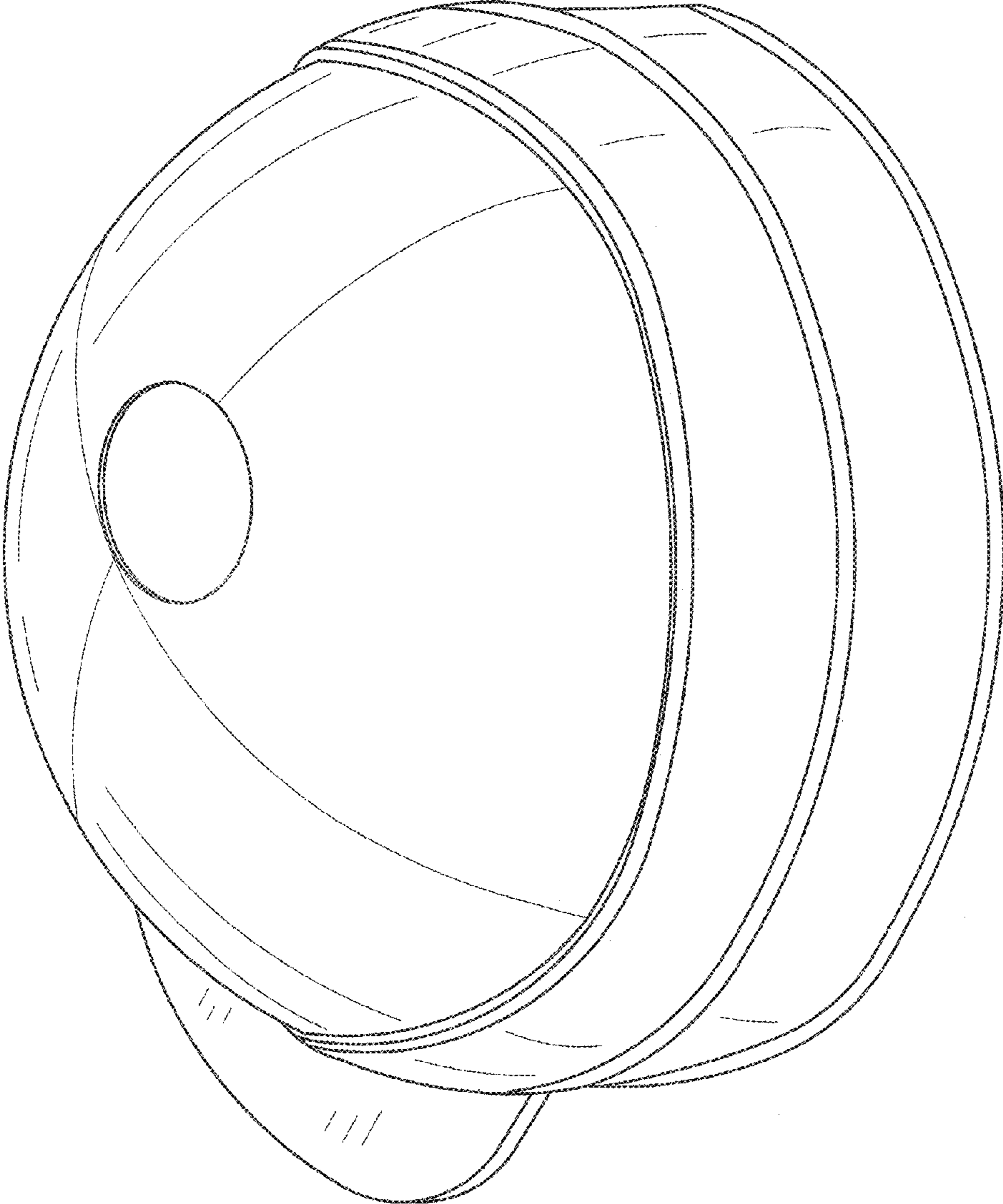

FIG. 7