

US00D691197S

(12) **United States Design Patent**
Casciotti et al.

(10) **Patent No.:** **US D691,197 S**

(45) **Date of Patent:** **** Oct. 8, 2013**

(54) **WRITING INSTRUMENT**

(75) Inventors: **David M. Casciotti**, Amsterdam, NY
(US); **Jing Mahler**, Glenville, NY (US)

(73) Assignee: **Holland USA, Inc.**, North Mankato, MN
(US)

(**) Term: **14 Years**

(21) Appl. No.: **29/420,713**

(22) Filed: **May 11, 2012**

(51) **LOC (9) Cl.** **19-06**

(52) **U.S. Cl.**
USPC **D19/50**

(58) **Field of Classification Search**
USPC D14/411; D19/35, 36, 41-51, 53-58;
24/11 F, 11 P, 11 R; 401/52, 99-109,
401/192, 195, 196
See application file for complete search history.

(56) **References Cited**

U.S. PATENT DOCUMENTS

D441,017 S *	4/2001	Gault et al.	D19/50
D506,506 S *	6/2005	Qiu	D19/50
D537,877 S *	3/2007	Bickert	D19/46
D540,386 S *	4/2007	Qiu	D19/51
D540,861 S *	4/2007	Bickert et al.	D19/42
D583,864 S *	12/2008	Liu	D19/48
D585,492 S *	1/2009	Booker	D19/50

D619,169 S *	7/2010	Kent et al.	D19/48
D619,170 S *	7/2010	Kent et al.	D19/55
D622,317 S *	8/2010	Li	D19/50
D633,142 S *	2/2011	Chaffee et al.	D19/36
D641,405 S *	7/2011	Guo	D19/48
D662,984 S *	7/2012	Yan	D19/50

* cited by examiner

Primary Examiner — Elizabeth Albert

(74) *Attorney, Agent, or Firm* — Dicke, Billig & Czaja,
PLLC

(57) **CLAIM**

We claim the ornamental design for a writing instrument, as shown and described.

DESCRIPTION

FIG. 1 is a perspective view of a writing instrument showing our new design;
FIG. 2 is a front view of FIG. 1;
FIG. 3 is a back view of FIG. 1;
FIG. 4 is a left side view of FIG. 1, the right side view being a mirror image of the left side view;
FIG. 5 is a top view of FIG. 1; and,
FIG. 6 is a bottom view of FIG. 1.
Portions of the writing instrument shown in broken lines are for the purpose of showing features that form no part of the claimed design.

1 Claim, 4 Drawing Sheets

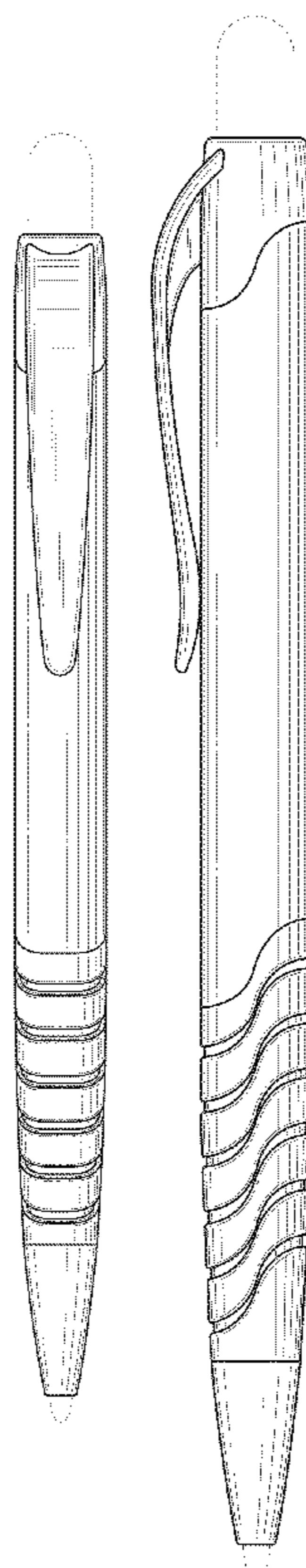

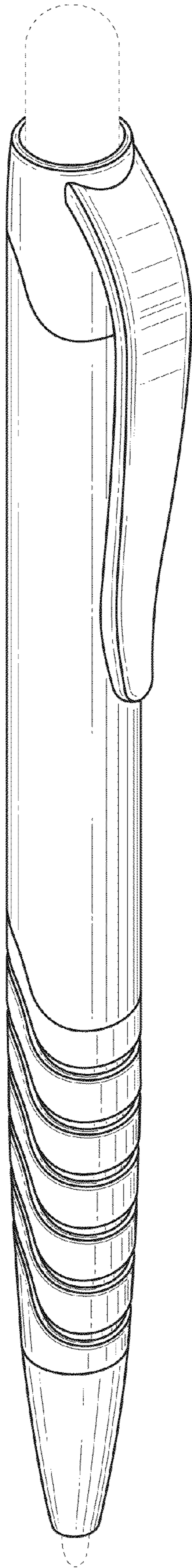

Fig. 1

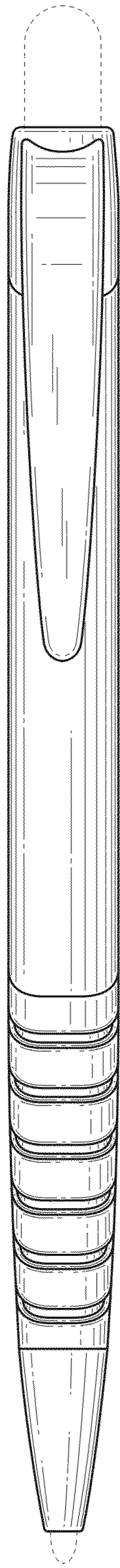

Fig. 2

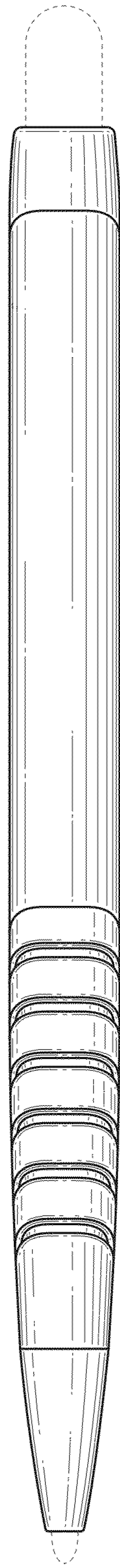

Fig. 3

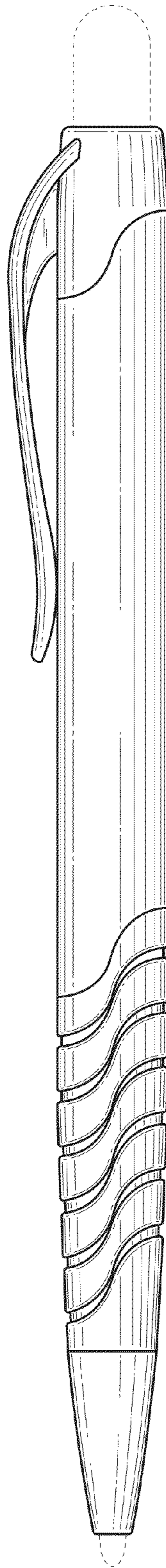

Fig. 4

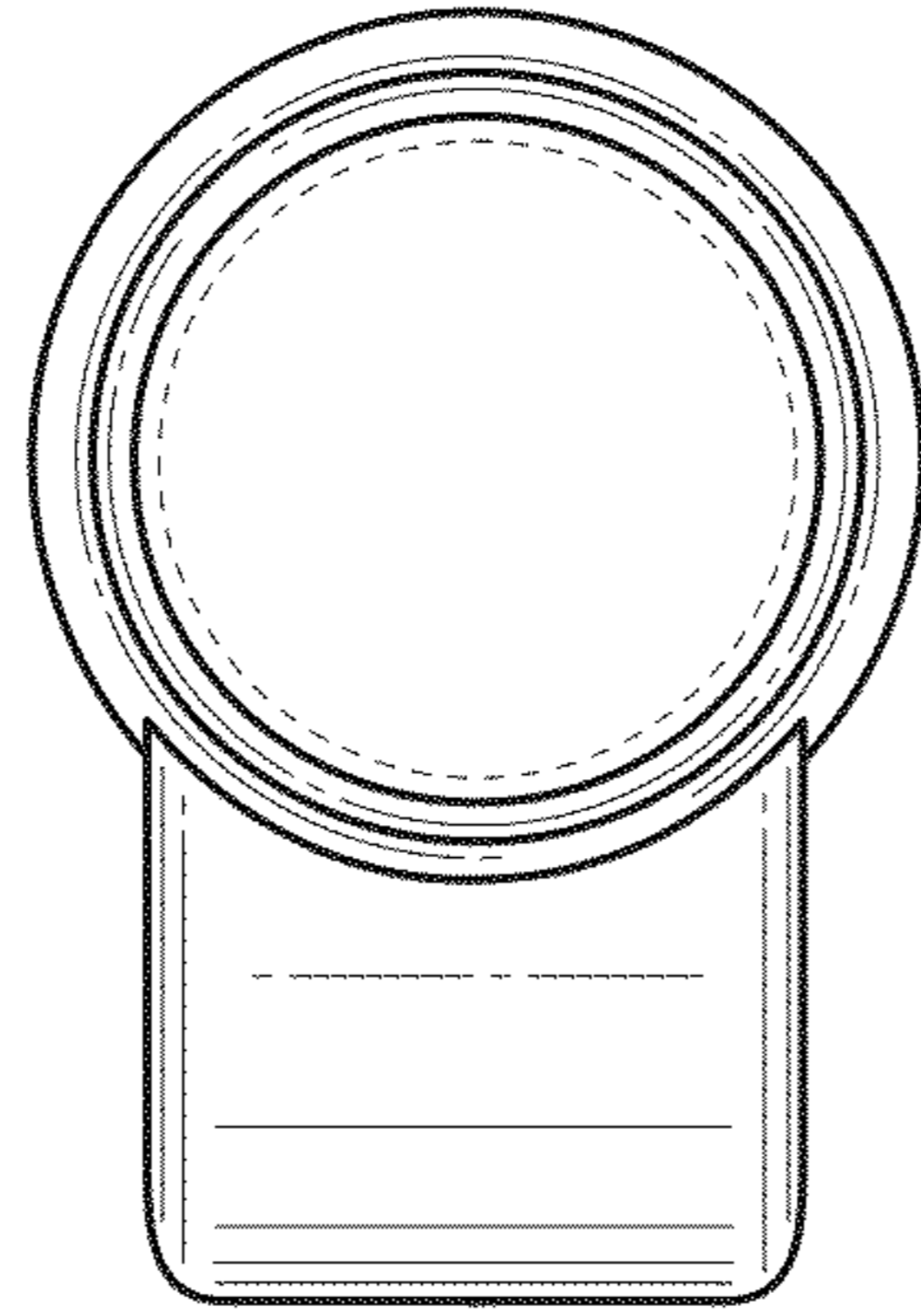

Fig. 5

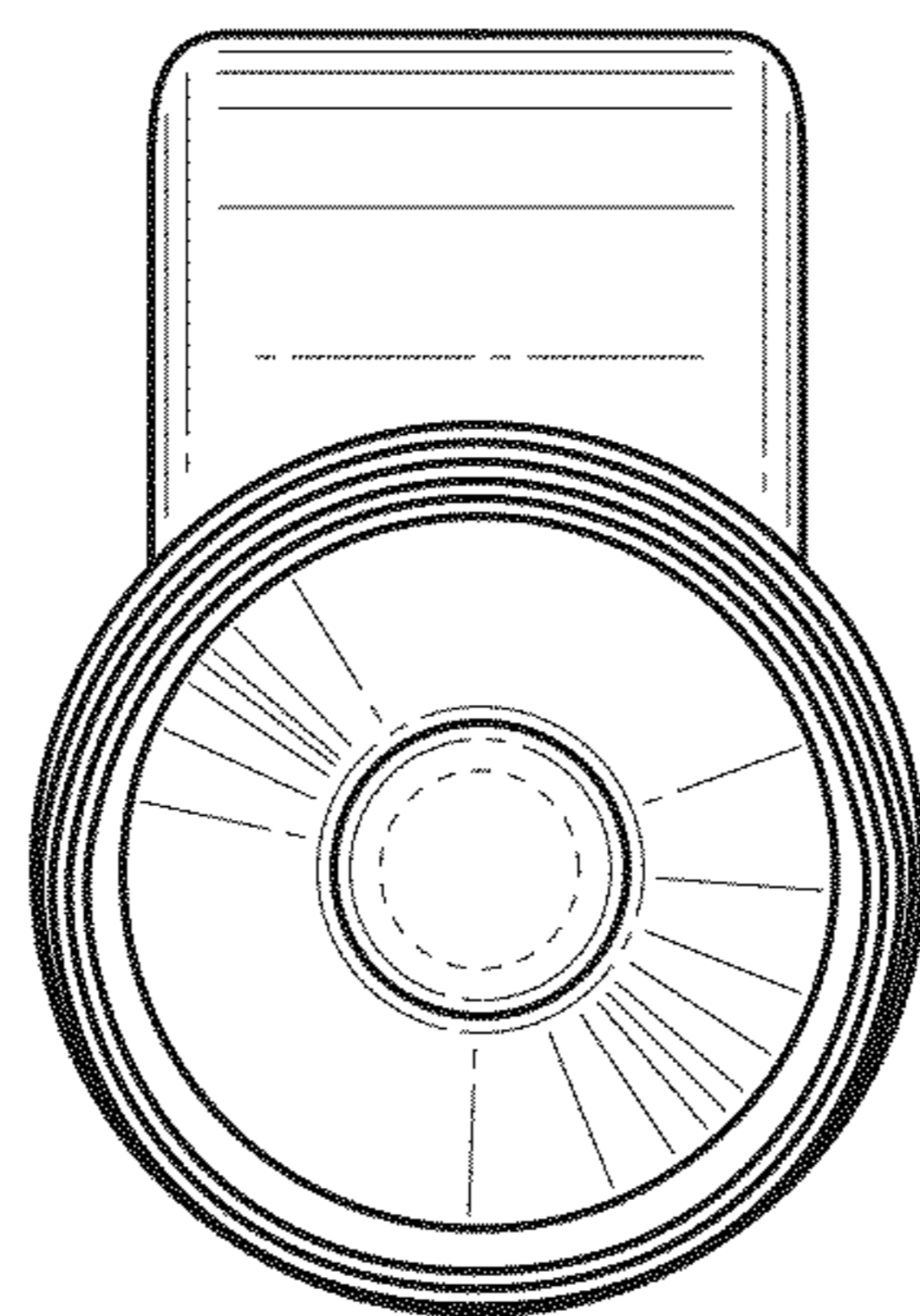

Fig. 6