



US00D691069S

(12) **United States Design Patent**
Tsukui et al.

(10) **Patent No.:** **US D691,069 S**
(45) **Date of Patent:** **** Oct. 8, 2013**

(54) **MOTORCYCLE OR MOTORCYCLE
REPLICA**

(71) Applicant: **Honda Motor Co., Ltd.**, Tokyo (JP)
(72) Inventors: **Hiroaki Tsukui**, Wako (JP); **Takatsugu
Kido**, Wako (JP)
(73) Assignee: **Honda Motor Co., Ltd.**, Tokyo (JP)
(**) Term: **14 Years**
(21) Appl. No.: **29/444,809**
(22) Filed: **Feb. 4, 2013**

(30) **Foreign Application Priority Data**
Aug. 7, 2012 (JP) 2012-018876
(51) **LOC (9) Cl.** **12-11**
(52) **U.S. Cl.**
USPC **D12/110**
(58) **Field of Classification Search**
USPC D12/110; 180/219, 220, 225, 229
See application file for complete search history.

(56) **References Cited**

U.S. PATENT DOCUMENTS

D516,468 S * 3/2006 Kuboshima et al. D12/110
D649,914 S * 12/2011 Marasco et al. D12/110
D652,769 S * 1/2012 Kudo et al. D12/110
D677,601 S * 3/2013 Yanagita et al. D12/110

* cited by examiner

Primary Examiner — Susan M Lee

Assistant Examiner — Linda G. Brooks

(74) *Attorney, Agent, or Firm* — Westerman, Hattori,
Daniels & Adrian, LLP

(57) **CLAIM**

The ornamental design for, a motorcycle or motorcycle replica, as shown and described.

DESCRIPTION

FIG. 1 is a first perspective view of a motorcycle or motorcycle replica, showing our new design;
FIG. 2 is a second perspective view thereof;
FIG. 3 is a front elevation view thereof;
FIG. 4 is a rear elevation view thereof;
FIG. 5 is a top plan view thereof;
FIG. 6 is a right side elevation view thereof; and,
FIG. 7 is a left side elevation view thereof.
The broken lines represent environmental structure only and form no part of the claimed design.

1 Claim, 7 Drawing Sheets

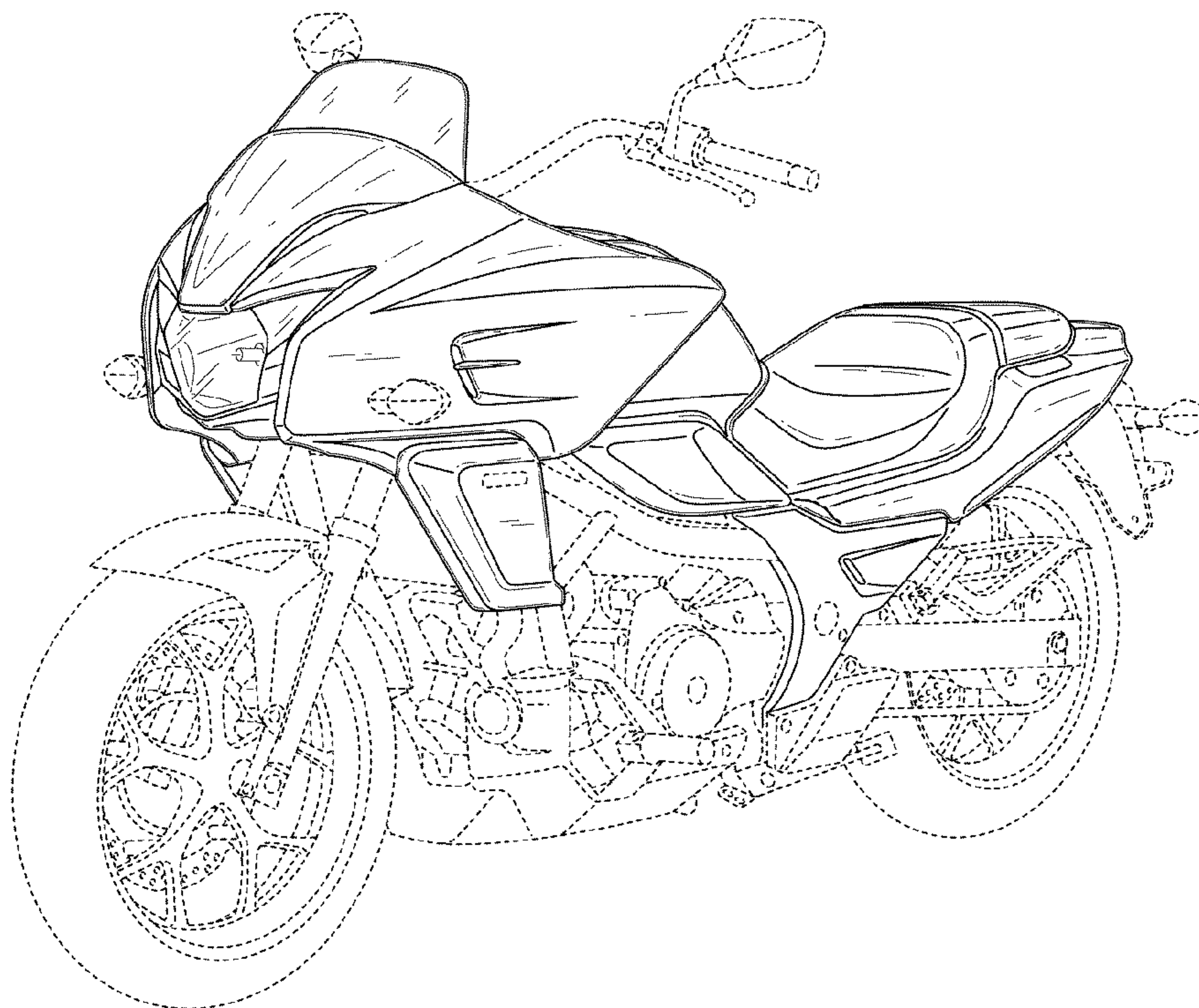

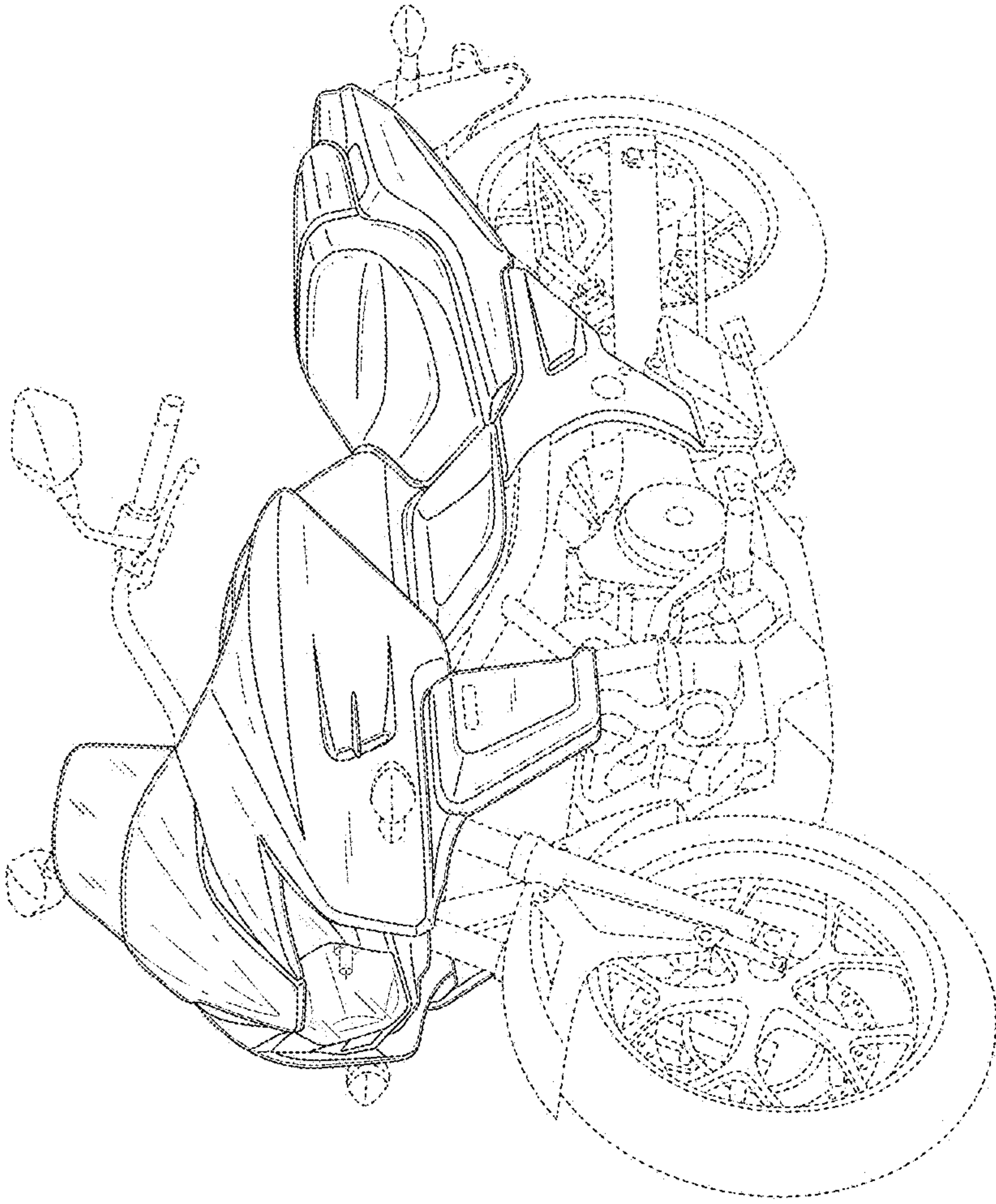

Fig. 1

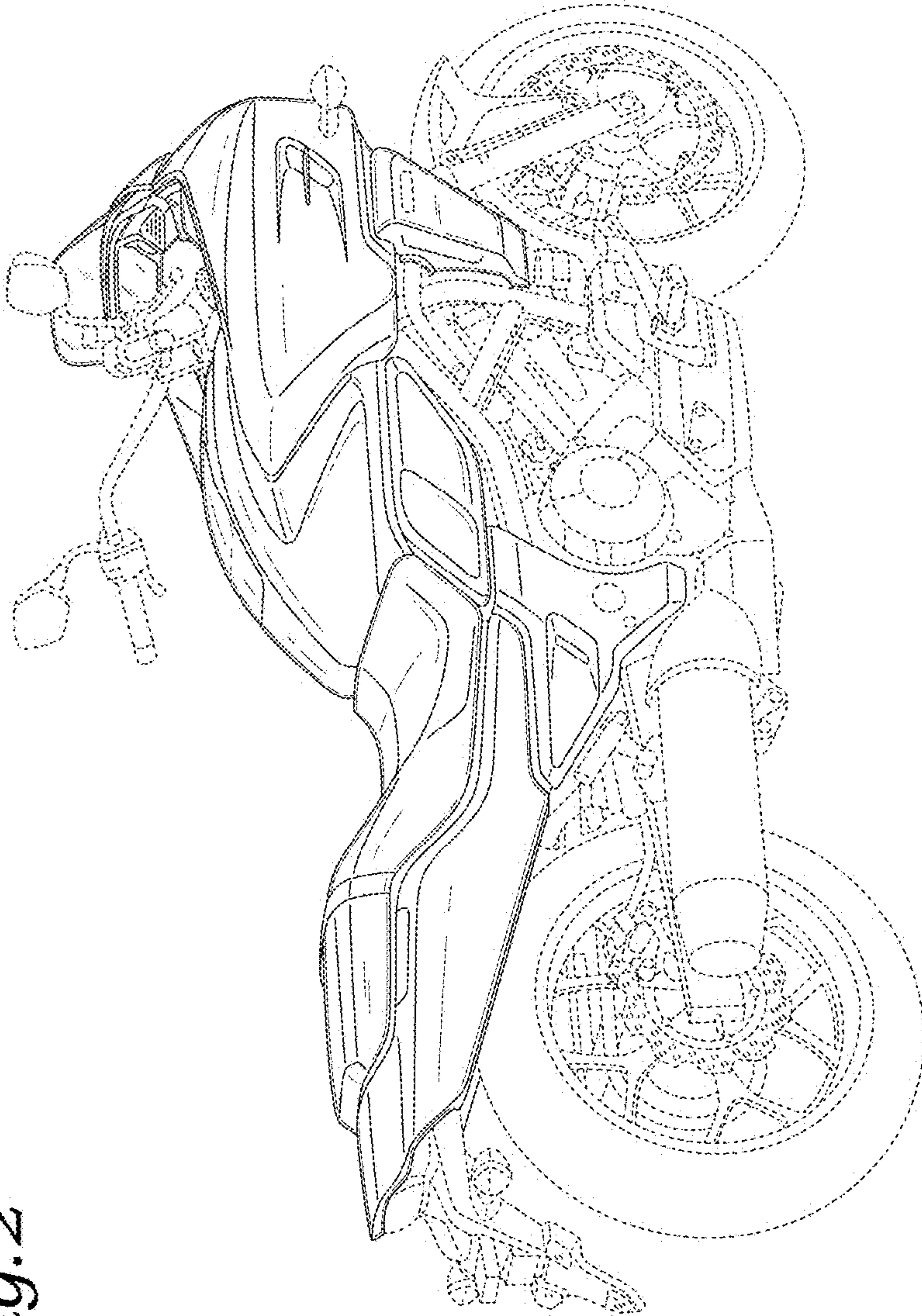

Fig. 2

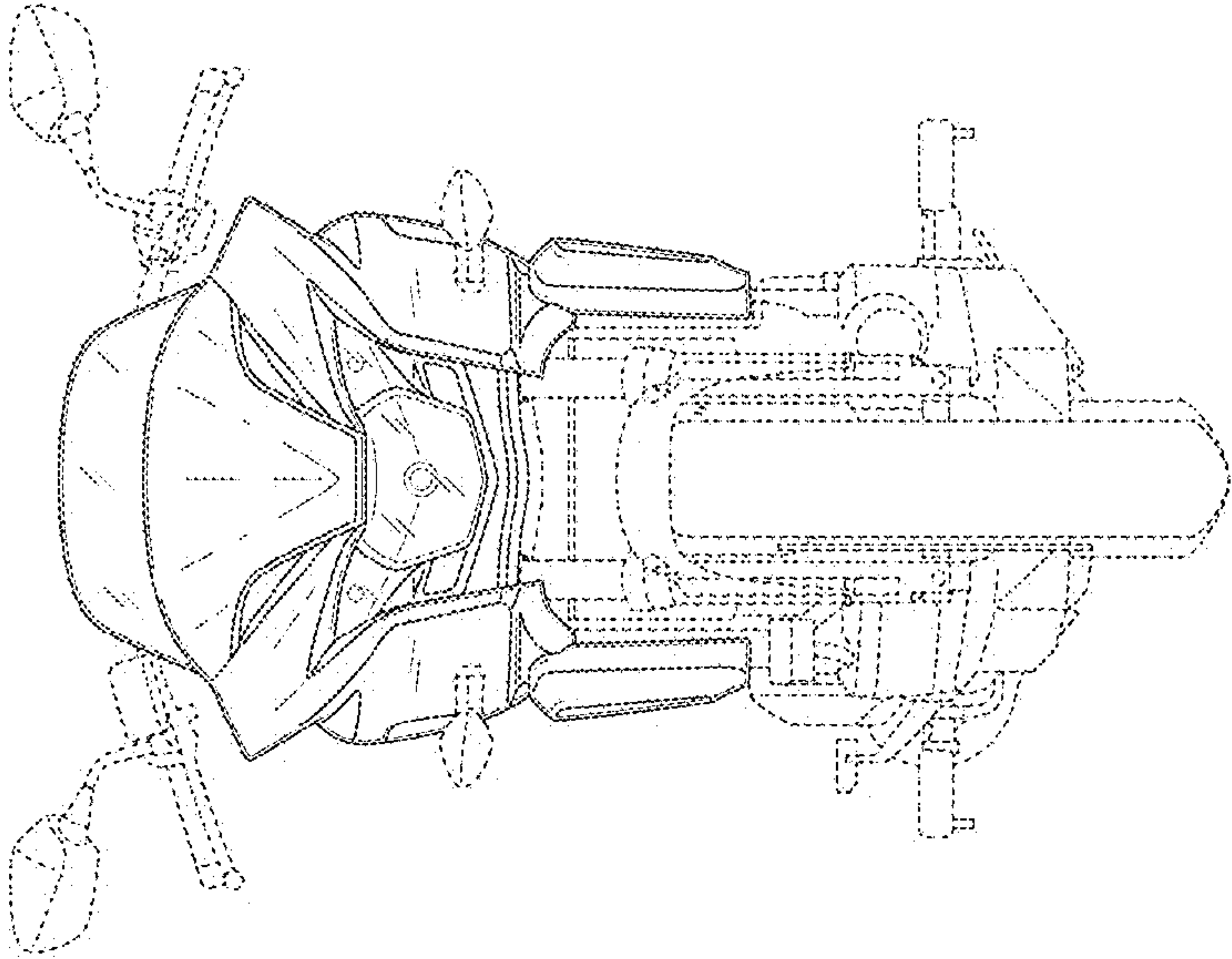

Fig. 3

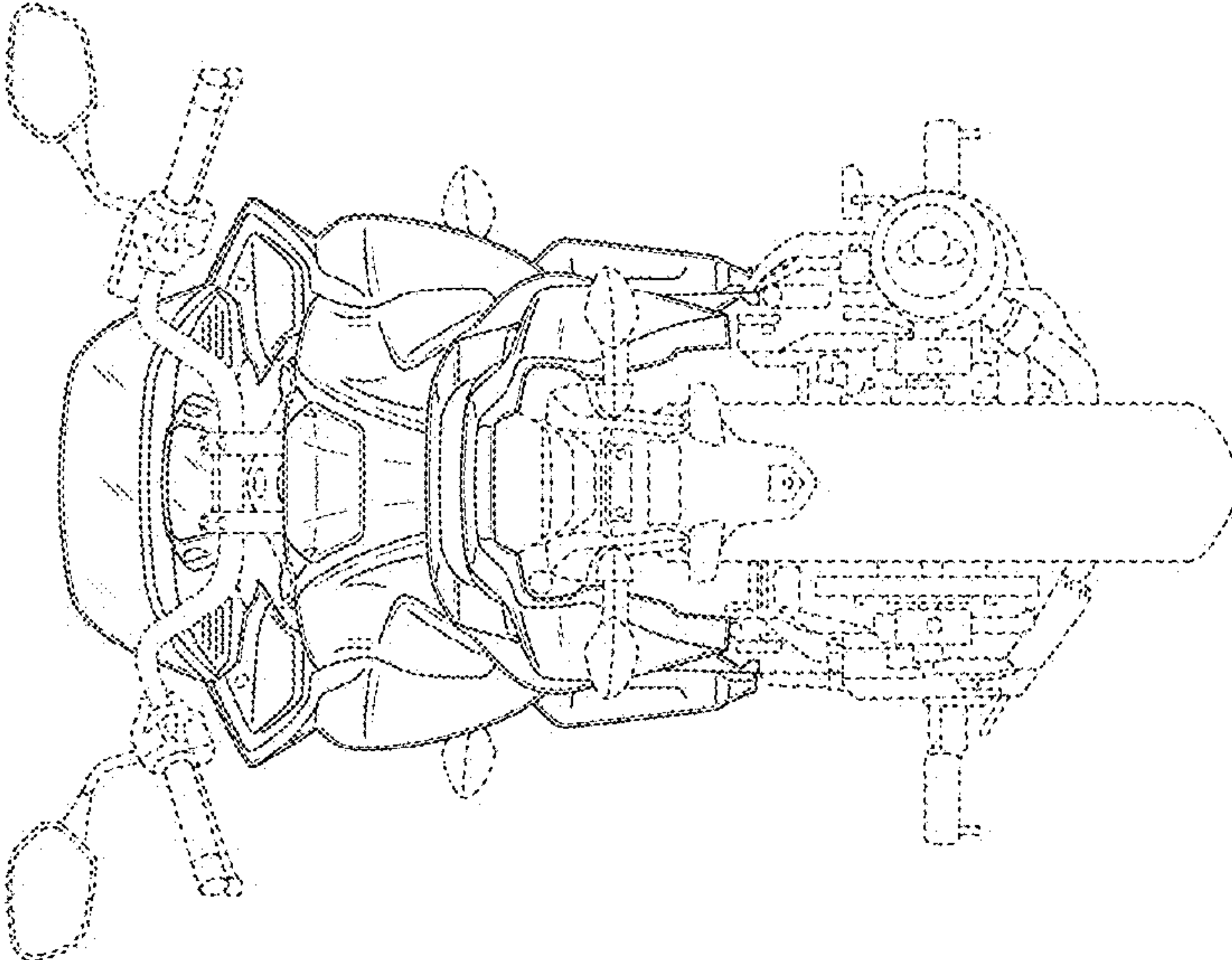

Fig. 4

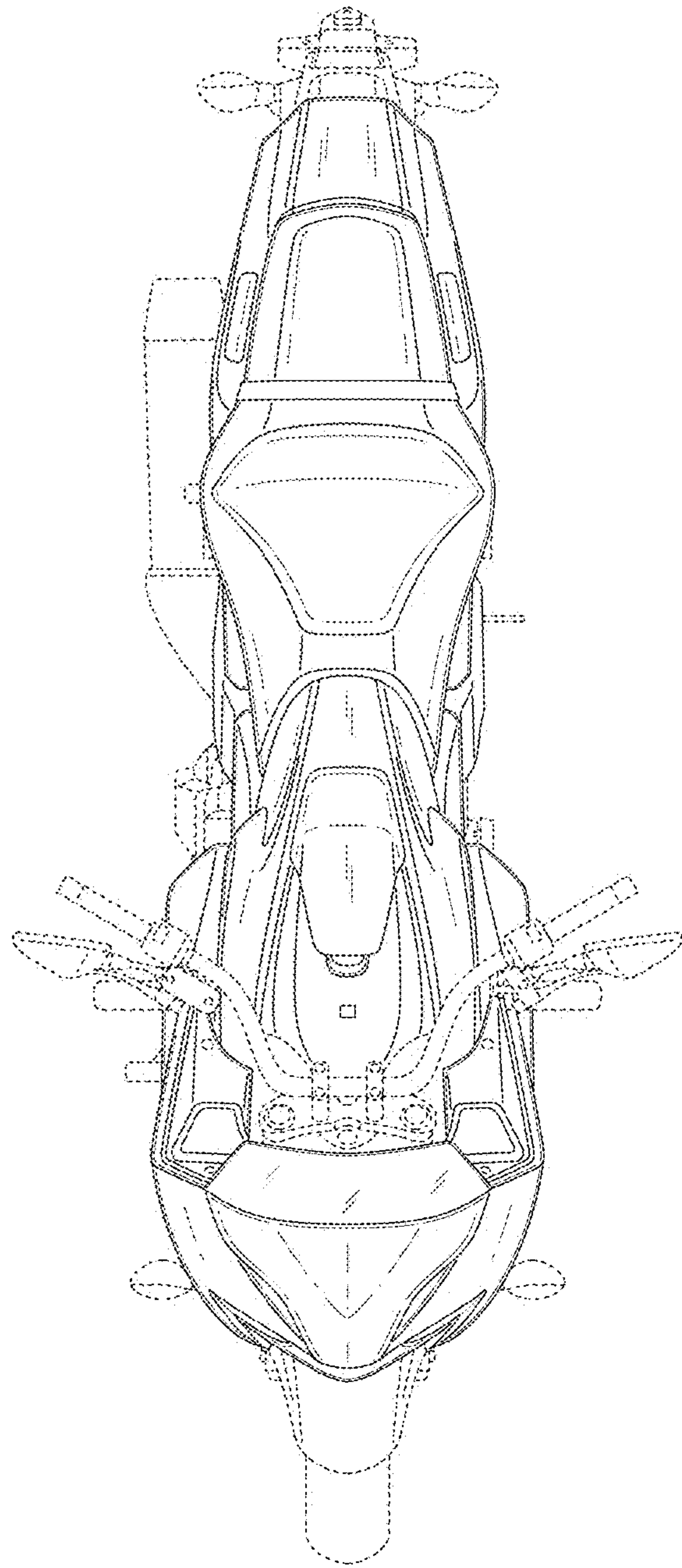

Fig. 5

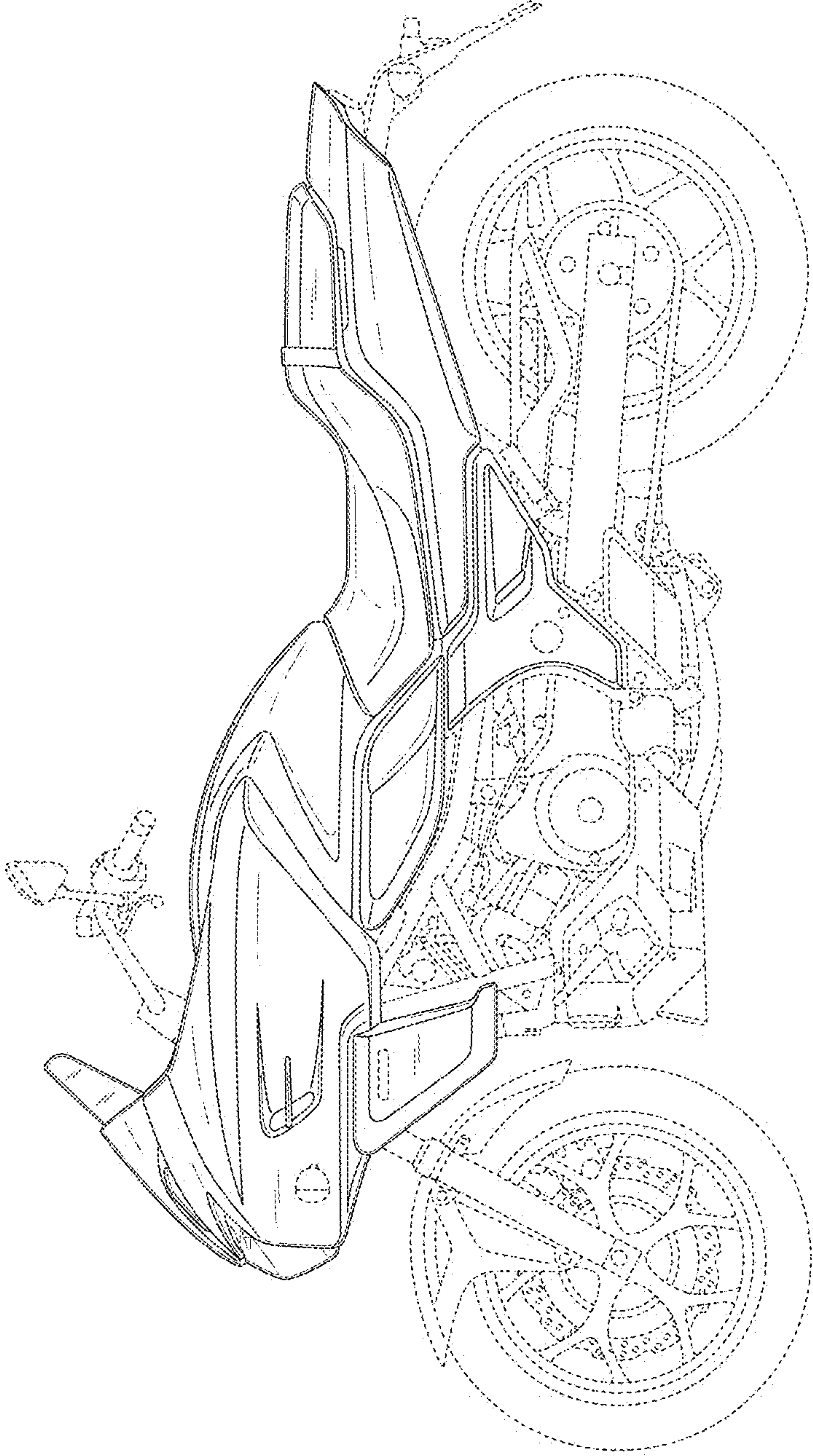

Fig. 6

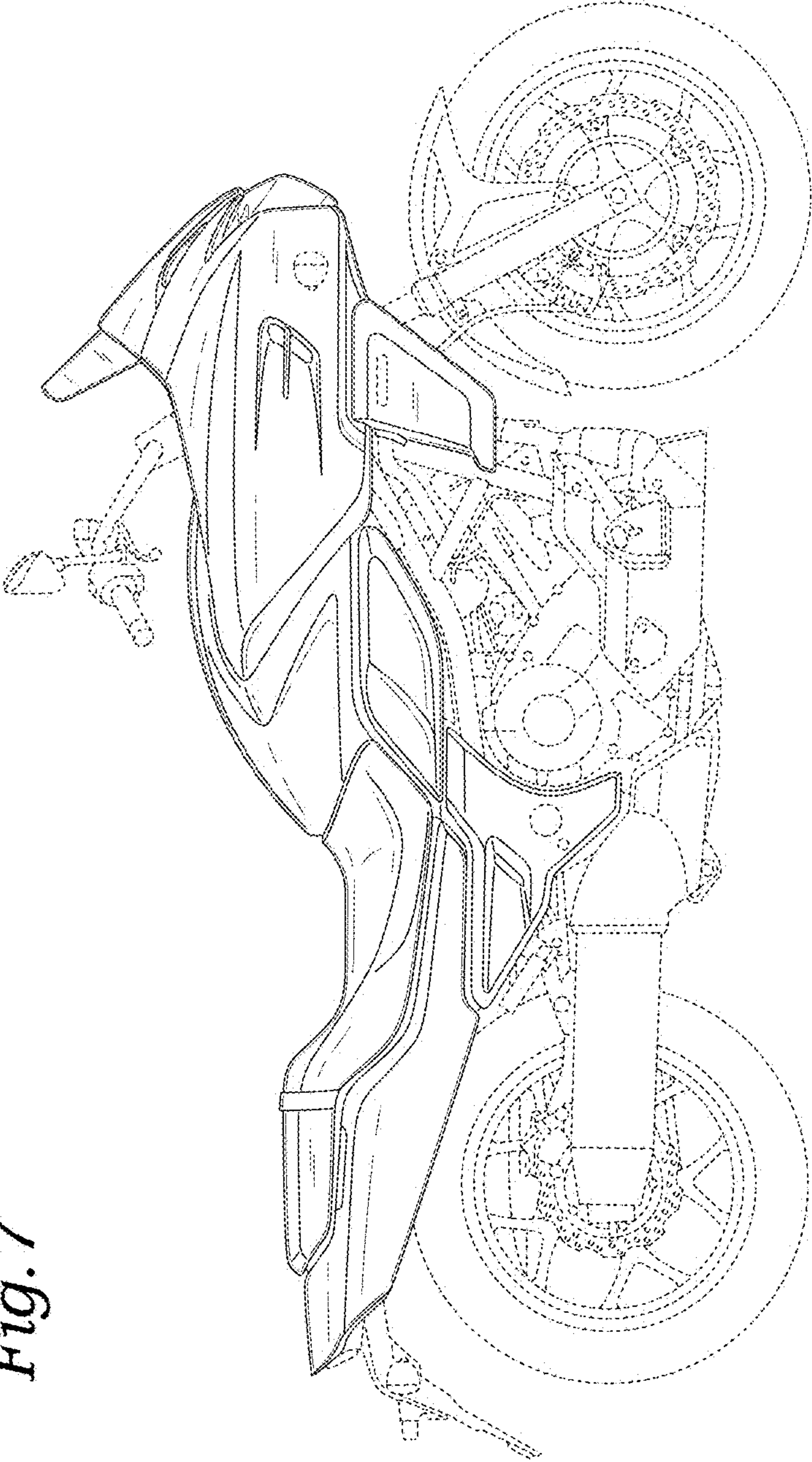

Fig. 7