



US00D690649S

(12) **United States Design Patent**
Lin et al.

(10) **Patent No.:** **US D690,649 S**
(45) **Date of Patent:** **** Oct. 1, 2013**

(54) **MOTOR SHELL**

(75) Inventors: **Yu-Ching Lin**, New Taipei (TW);
Chien-Yao Liao, New Taipei (TW);
Wen-Cheng Chen, New Taipei (TW)

(73) Assignee: **Foxconn Technology Co., Ltd.**, New Taipei (TW)

(**) Term: **14 Years**

(21) Appl. No.: **29/405,386**

(22) Filed: **Nov. 1, 2011**

(30) **Foreign Application Priority Data**

Oct. 21, 2011 (CN) 2011 3 0376412

(51) **LOC (9) Cl.** **13-01**

(52) **U.S. Cl.**
USPC **D13/122**

(58) **Field of Classification Search**
USPC D13/122, 112, 114, 118, 199, 179,
D13/184; D8/382; D12/180; D15/5; 310/71,
310/85, 86, 156.01, 156.53, 156.56, 194,
310/216, 254.1, 262, 263; 336/198, 200,
336/208; D23/336, 370, 377, 384, 411, 412
See application file for complete search history.

(56) **References Cited**

U.S. PATENT DOCUMENTS

D269,670 S * 7/1983 Fulmer et al. D13/122
D269,671 S * 7/1983 Horsting D13/122

D275,478 S * 9/1984 Griggs D13/122
D310,262 S * 8/1990 Lemire D23/377
D487,310 S * 3/2004 Li et al. D23/411
D530,278 S * 10/2006 Lyle et al. D13/122
D547,436 S * 7/2007 Shurtleff D23/411
D560,622 S * 1/2008 Ishihara et al. D13/179
D587,650 S * 3/2009 Lannoch D13/122
D631,438 S * 1/2011 Yokoyama et al. D13/122
D632,384 S * 2/2011 Pan D23/411
D642,527 S * 8/2011 Li et al. D13/122

* cited by examiner

Primary Examiner — Derrick Holland

(74) *Attorney, Agent, or Firm* — Wei Te Chung; Ming Chieh Chang

(57) **CLAIM**

The ornamental design for a motor shell, as shown and described.

DESCRIPTION

FIG. 1 is a perspective view of a motor shell showing our new design.
FIG. 2 is a front elevational view of the motor shell.
FIG. 3 is a rear elevational view of the motor shell.
FIG. 4 is a left-side, elevational view of the motor shell.
FIG. 5 is a right-side, elevational view of the motor shell.
FIG. 6 is a top plan view of the motor shell.
FIG. 7 is a bottom plan view of the motor shell; and,
FIG. 8 is a cross-sectional view of the motor shell, taken along line 8-8 of FIG. 2.

1 Claim, 8 Drawing Sheets

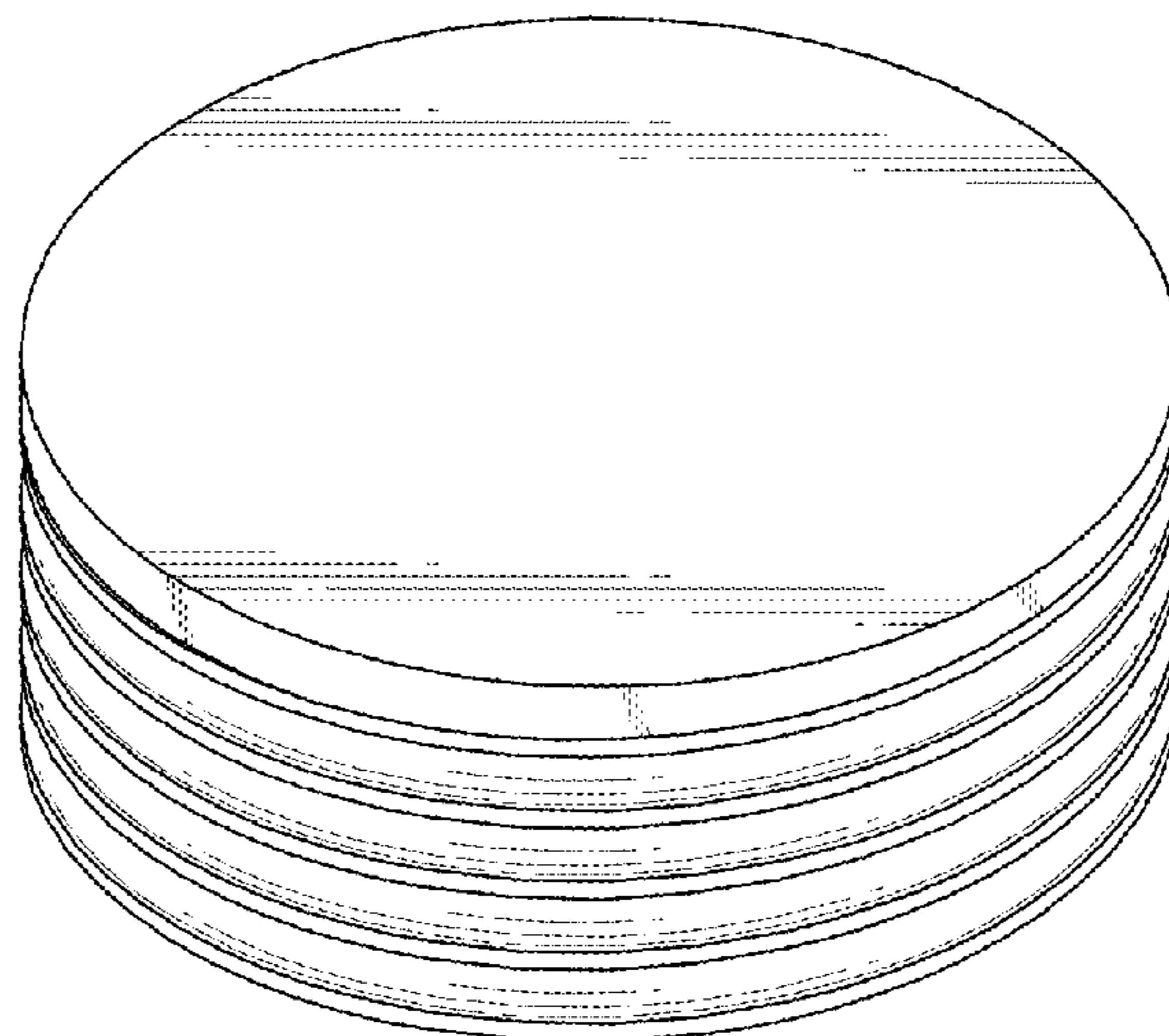

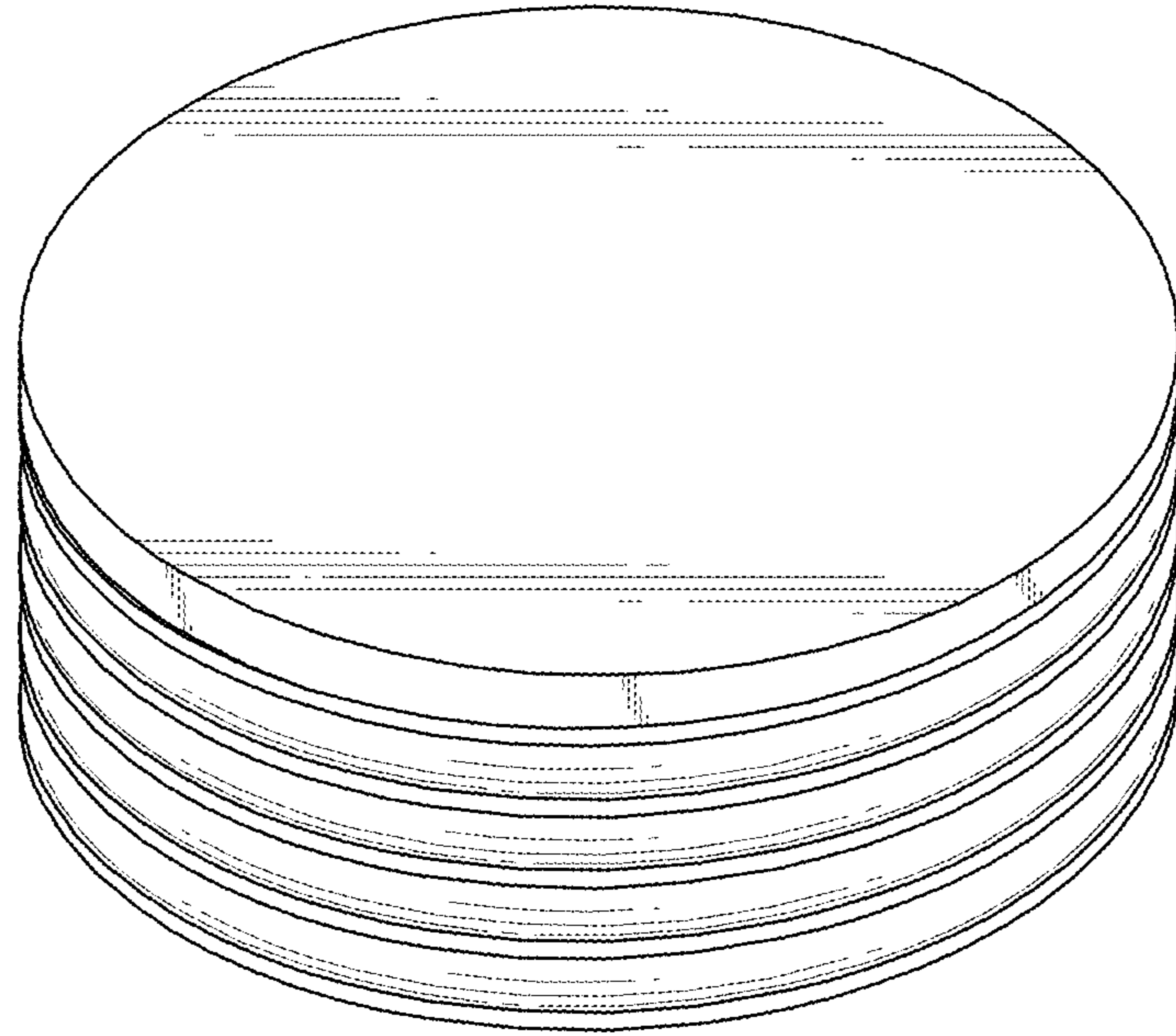

FIG. 1

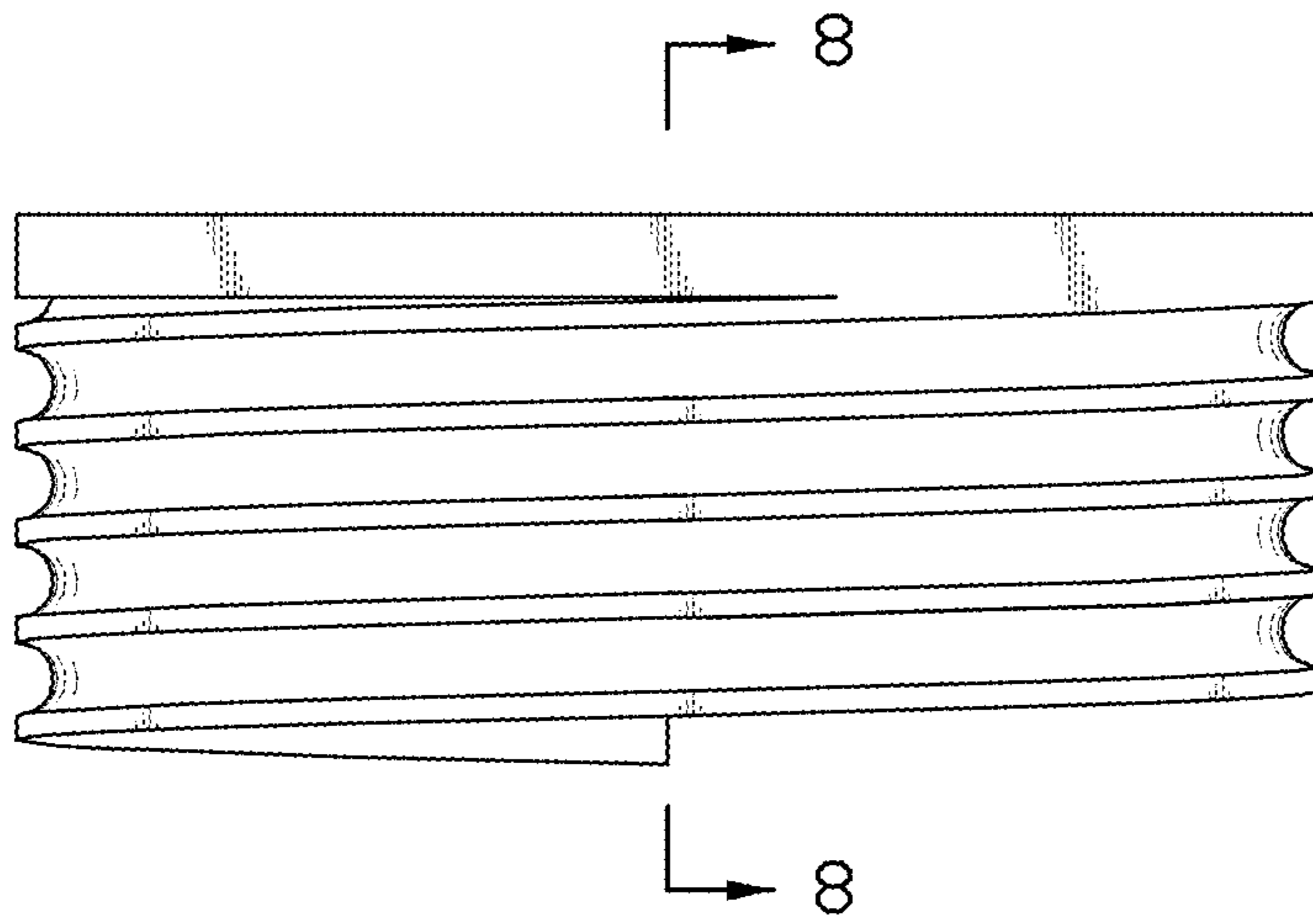

FIG. 2

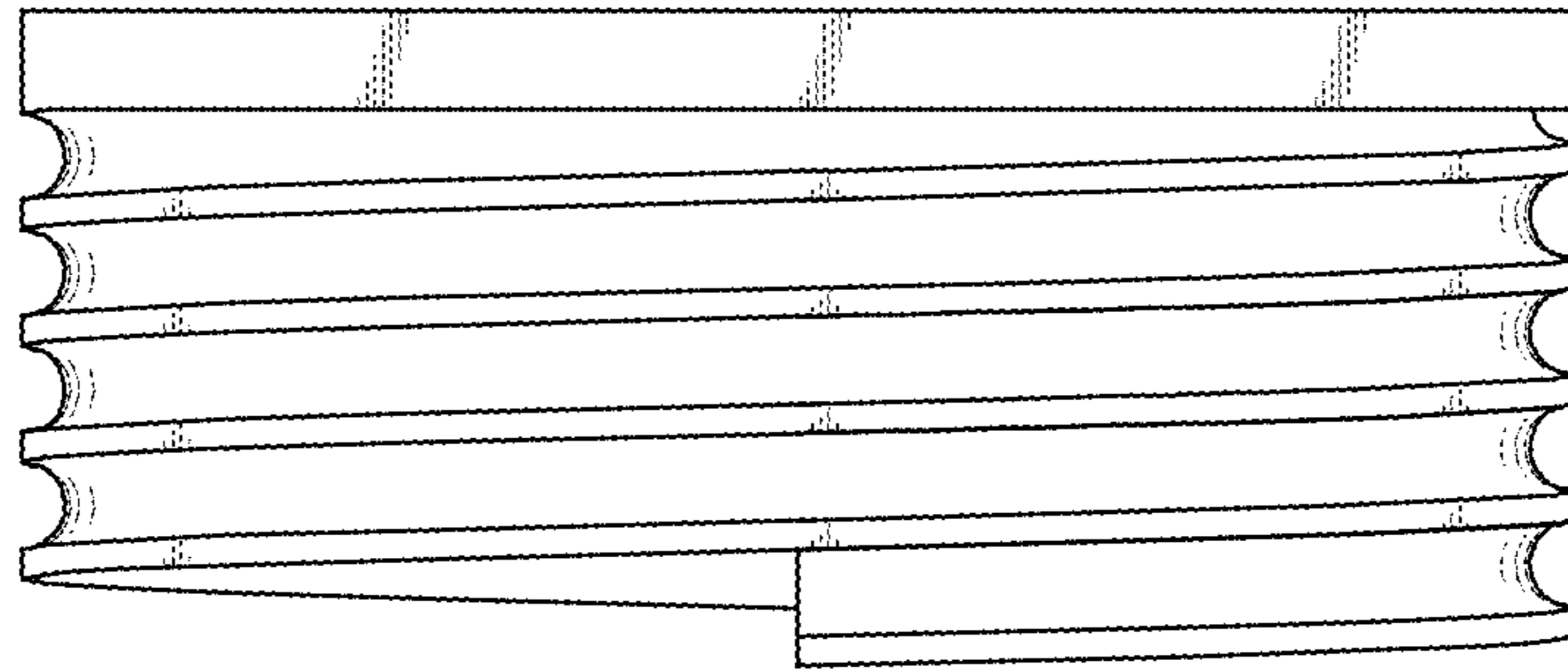

FIG. 3

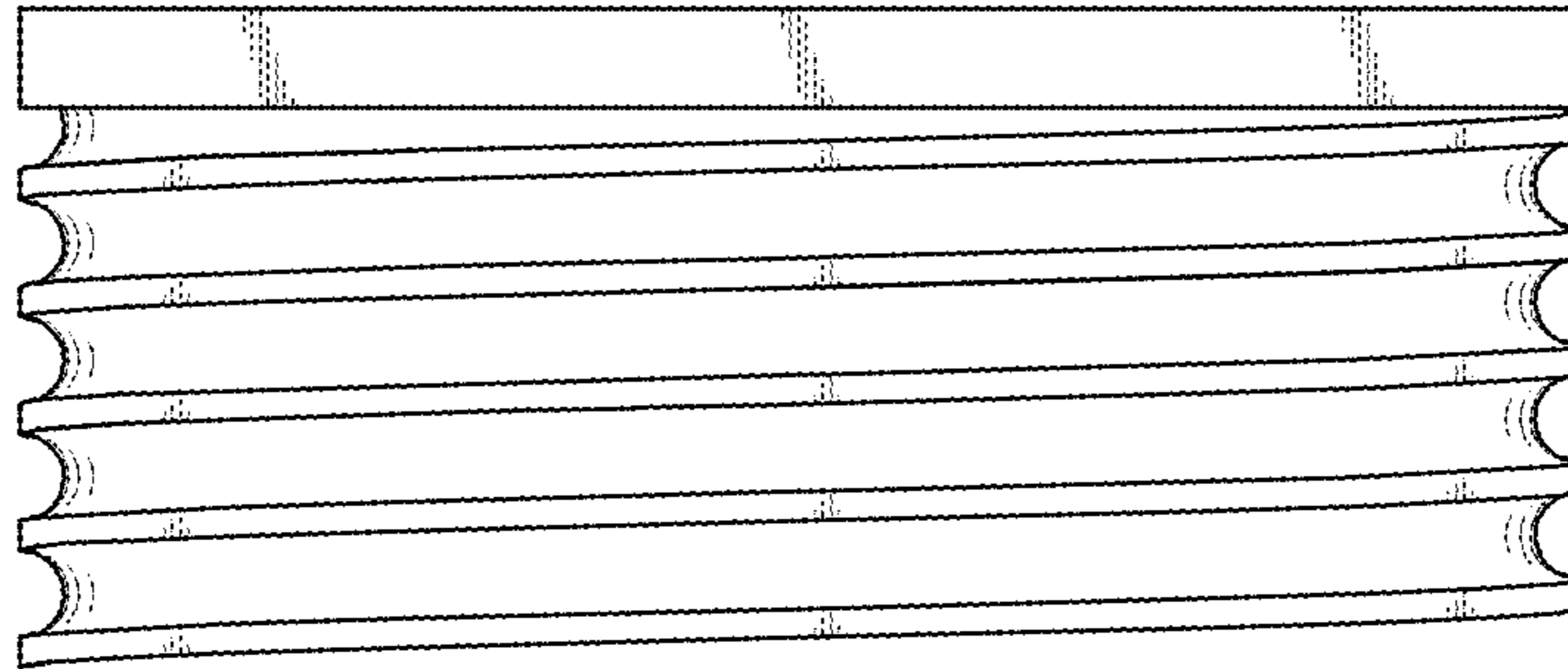

FIG. 4

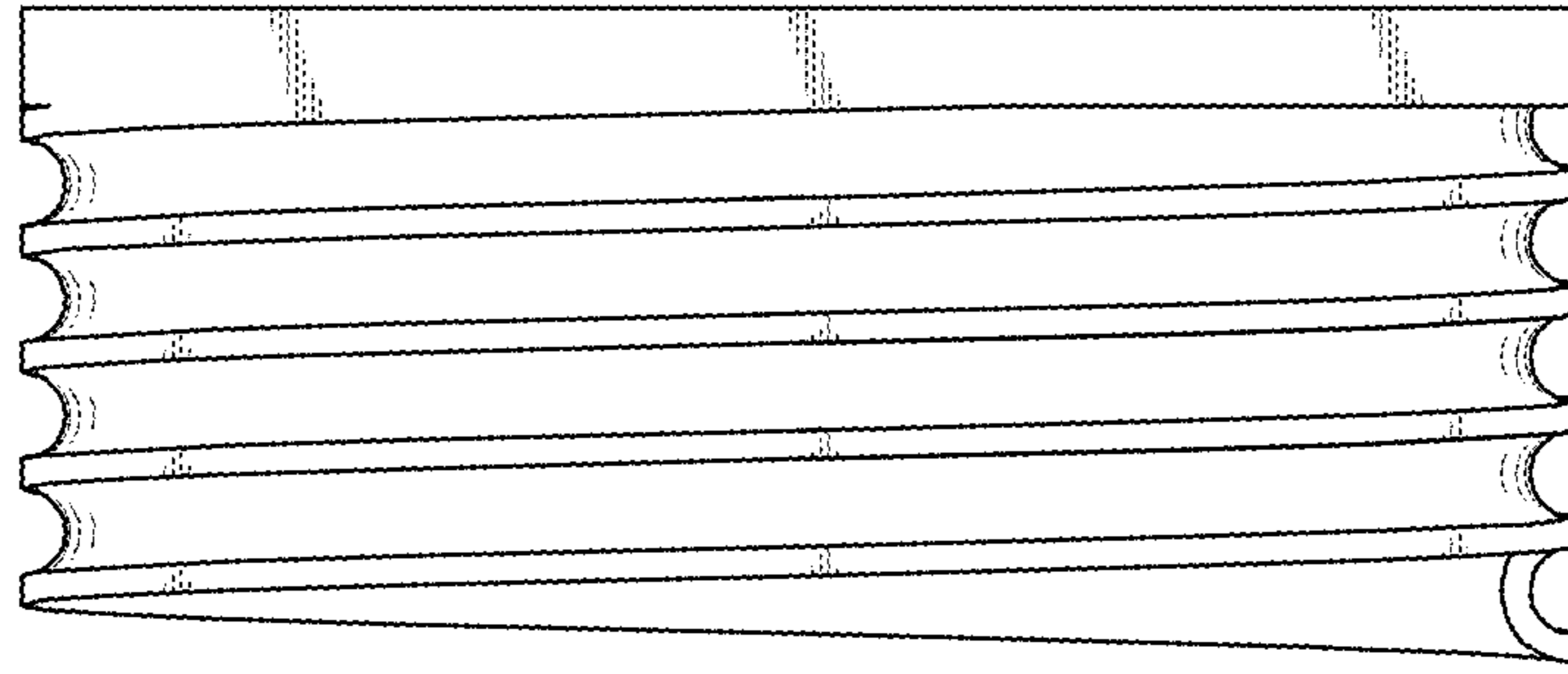

FIG. 5

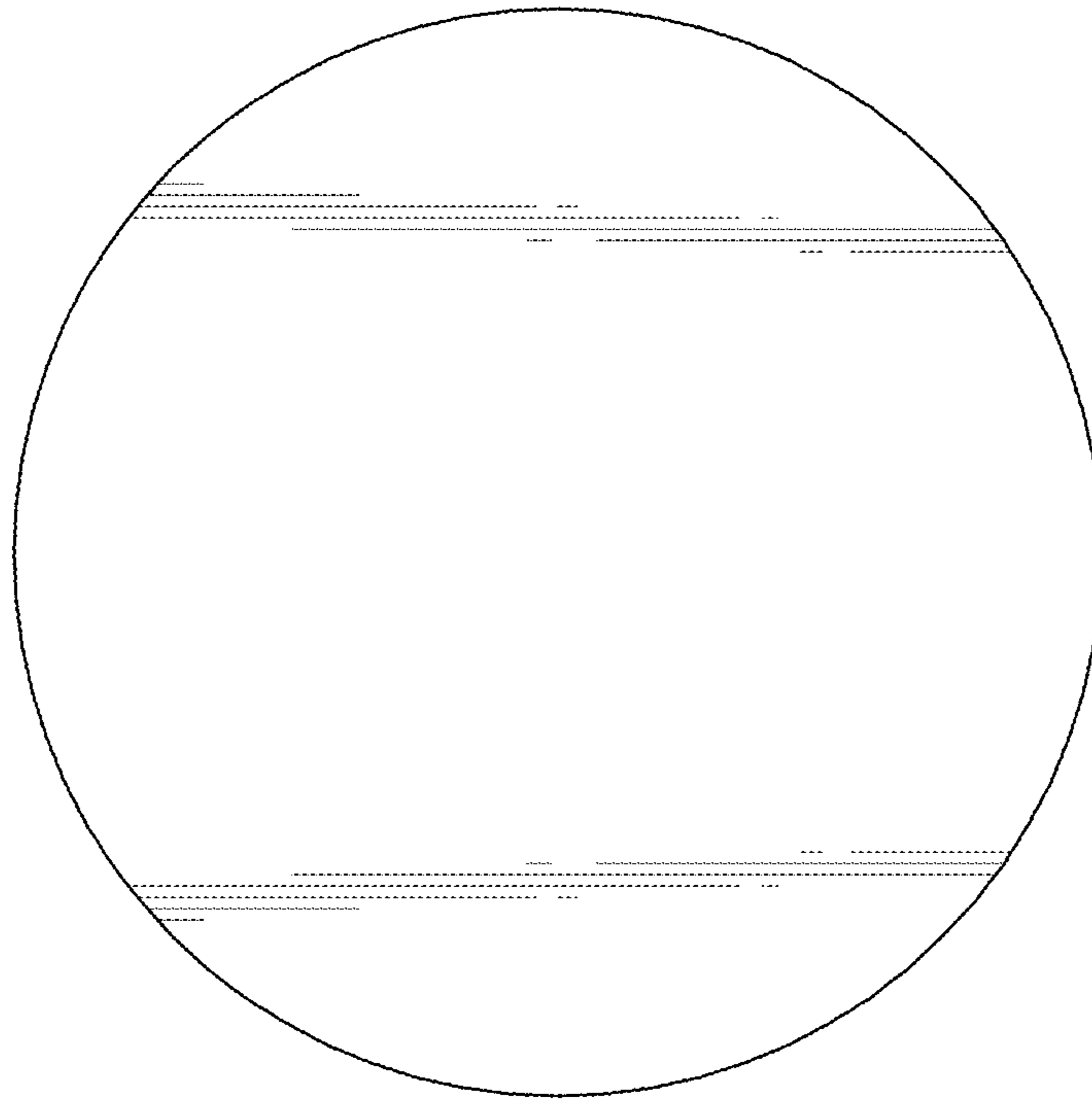

FIG. 6

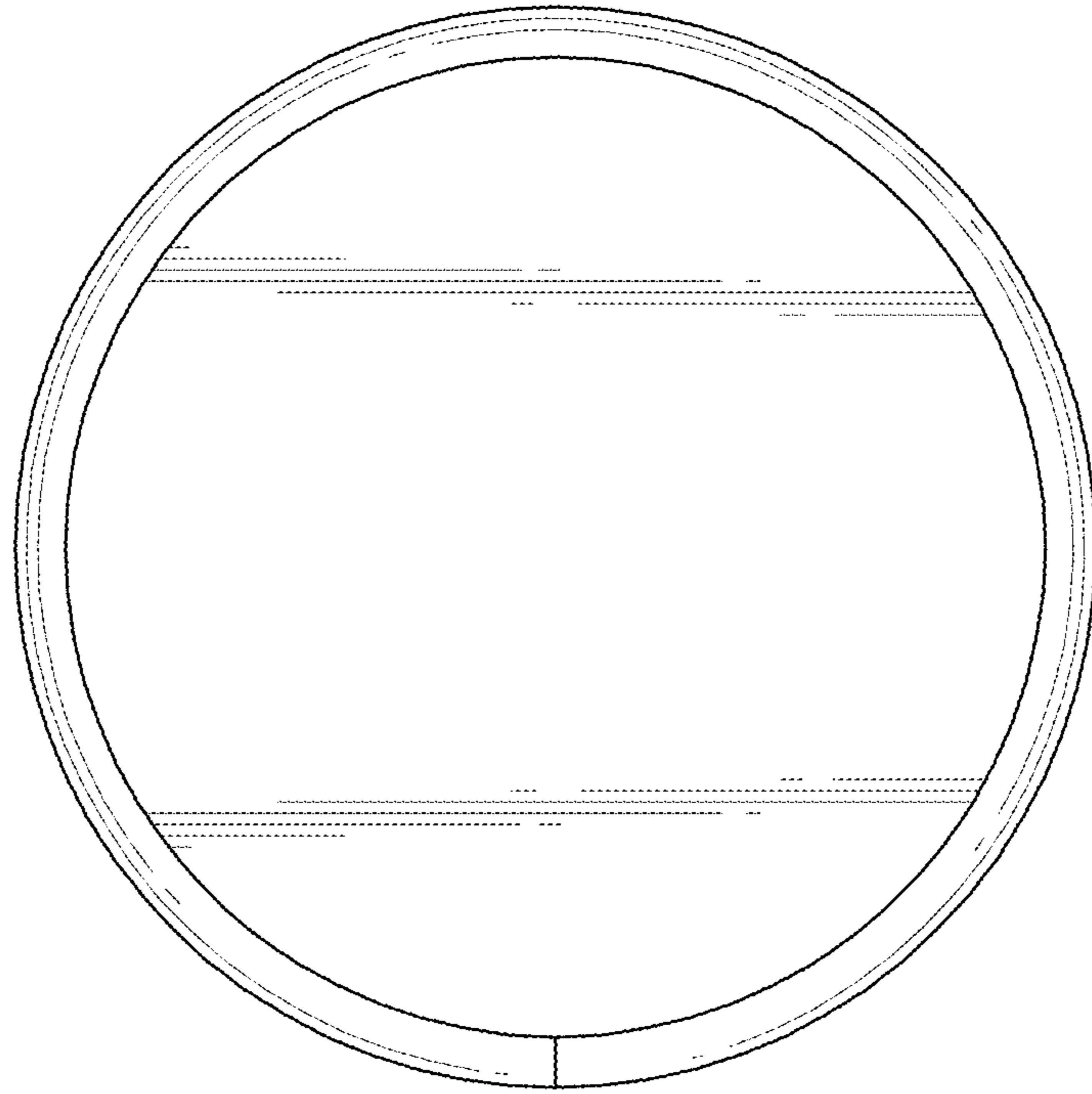

FIG. 7

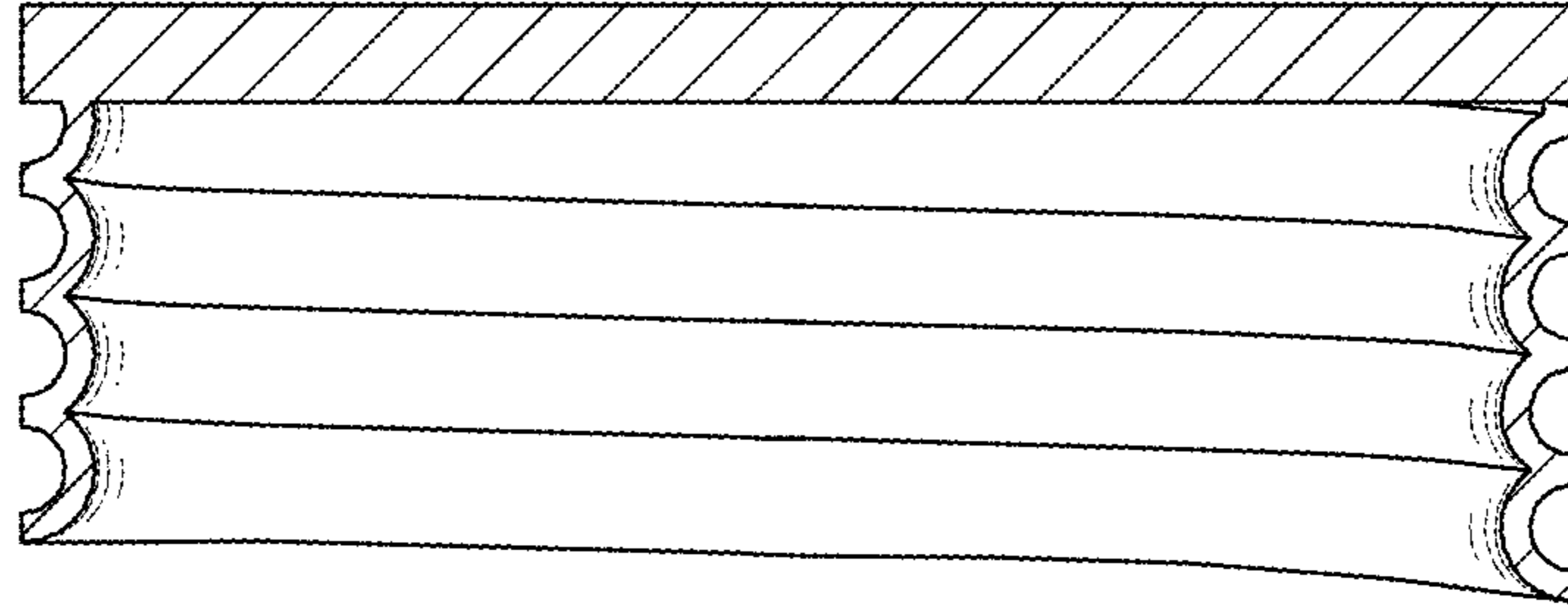

FIG. 8