

US00D690640S

(12) **United States Design Patent**  
**Morioka**

(10) **Patent No.:** **US D690,640 S**

(45) **Date of Patent:** **\*\* Oct. 1, 2013**

(54) **AUTOMOBILE AND/OR REPLICA**

(75) Inventor: **Keisuke Morioka**, Tokyo (JP)

(73) Assignee: **Honda Motor Co., Ltd**, Tokyo (JP)

(\*\*) Term: **14 Years**

(21) Appl. No.: **29/417,422**

(22) Filed: **Apr. 3, 2012**

(51) **LOC (9) Cl.** ..... **12-16**

(52) **U.S. Cl.**  
USPC ..... **D12/196**

(58) **Field of Classification Search**

USPC ..... D12/86, 90, 91, 92, 164, 167, 196;  
296/181.1, 181.5; 293/102, 113, 115, 117,  
293/120

See application file for complete search history.

<URL: [http://www.auto-brochures.com/makes/Honda/Crosstour/Honda\\_US%20Crosstour\\_2011.pdf](http://www.auto-brochures.com/makes/Honda/Crosstour/Honda_US%20Crosstour_2011.pdf)>.\*

2012 Honda Accord Crosstour. Electronic Brochure. Jan. 23, 2012 [online], [retrieved on Apr. 17, 2013]. Retrieved from the Internet <URL: [http://www.auto-brochures.com/makes/Honda/Crosstour/Honda\\_US%20Crosstour\\_2012.pdf](http://www.auto-brochures.com/makes/Honda/Crosstour/Honda_US%20Crosstour_2012.pdf)>.\*

\* cited by examiner

*Primary Examiner* — Philip S Hyder

*Assistant Examiner* — Darlington Ly

(74) *Attorney, Agent, or Firm* — Westerman, Hattori, Daniels & Adrian, LLP

(57) **CLAIM**

The ornamental design for an automobile and/or replica, as shown and described.

(56) **References Cited**

**U.S. PATENT DOCUMENTS**

D293,311 S *	12/1987	Strosek	.....	D12/169
D432,065 S *	10/2000	Kitamura	.....	D12/196
D438,497 S *	3/2001	Yokomaku	.....	D12/190
D551,125 S *	9/2007	Uchino et al.	.....	D12/92
D582,819 S *	12/2008	Miyazawa et al.	.....	D12/169
D613,435 S *	4/2010	Schell et al.	.....	D26/28
D617,018 S *	6/2010	Schell et al.	.....	D26/28
D619,048 S *	7/2010	Christensen et al.	.....	D12/92
D619,508 S *	7/2010	Choi et al.	.....	D12/164
D619,509 S *	7/2010	Choi et al.	.....	D12/164
D622,187 S *	8/2010	Kono et al.	.....	D12/92
D630,978 S *	1/2011	Koshino et al.	.....	D12/169

**OTHER PUBLICATIONS**

2011 Honda Accord Crosstour. Electronic Brochure. Sep. 10, 2010 [online], [retrieved on Apr. 17, 2013]. Retrieved from the Internet

**DESCRIPTION**

FIG. 1 is a front elevational view of an automobile and/or replica showing my new design;  
FIG. 2 is a left front perspective view thereof;  
FIG. 3 is a left side elevational view thereof, the right side elevational view being a mirror image thereof;  
FIG. 4 is a left rear perspective view thereof;  
FIG. 5 is a rear elevational view thereof; and,  
FIG. 6 is a top plan view thereof.

The even broken lines shown in the drawings illustrate portions of the automobile and/or replica that forms no part of claimed design. The dash-dot broken lines represent boundaries of the claimed design and form no part thereof.

**1 Claim, 6 Drawing Sheets**

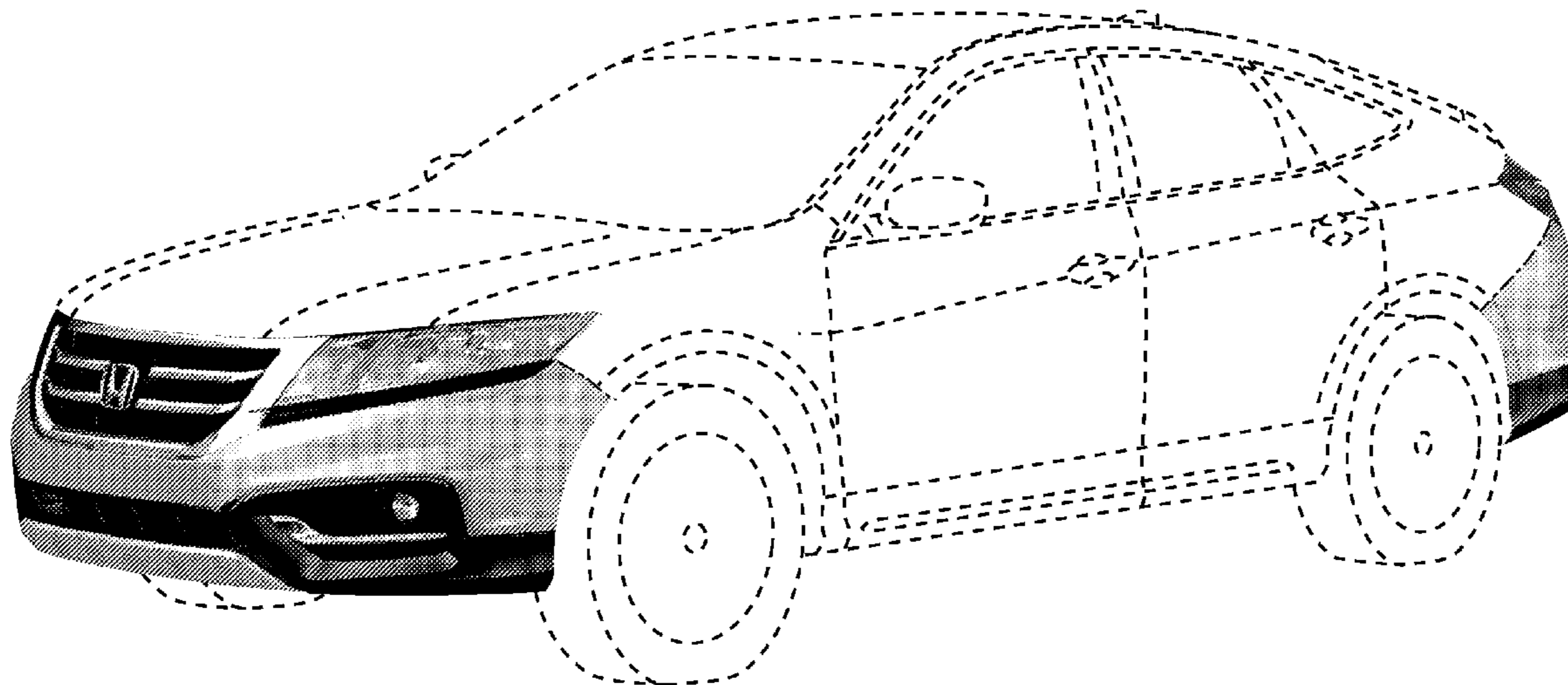

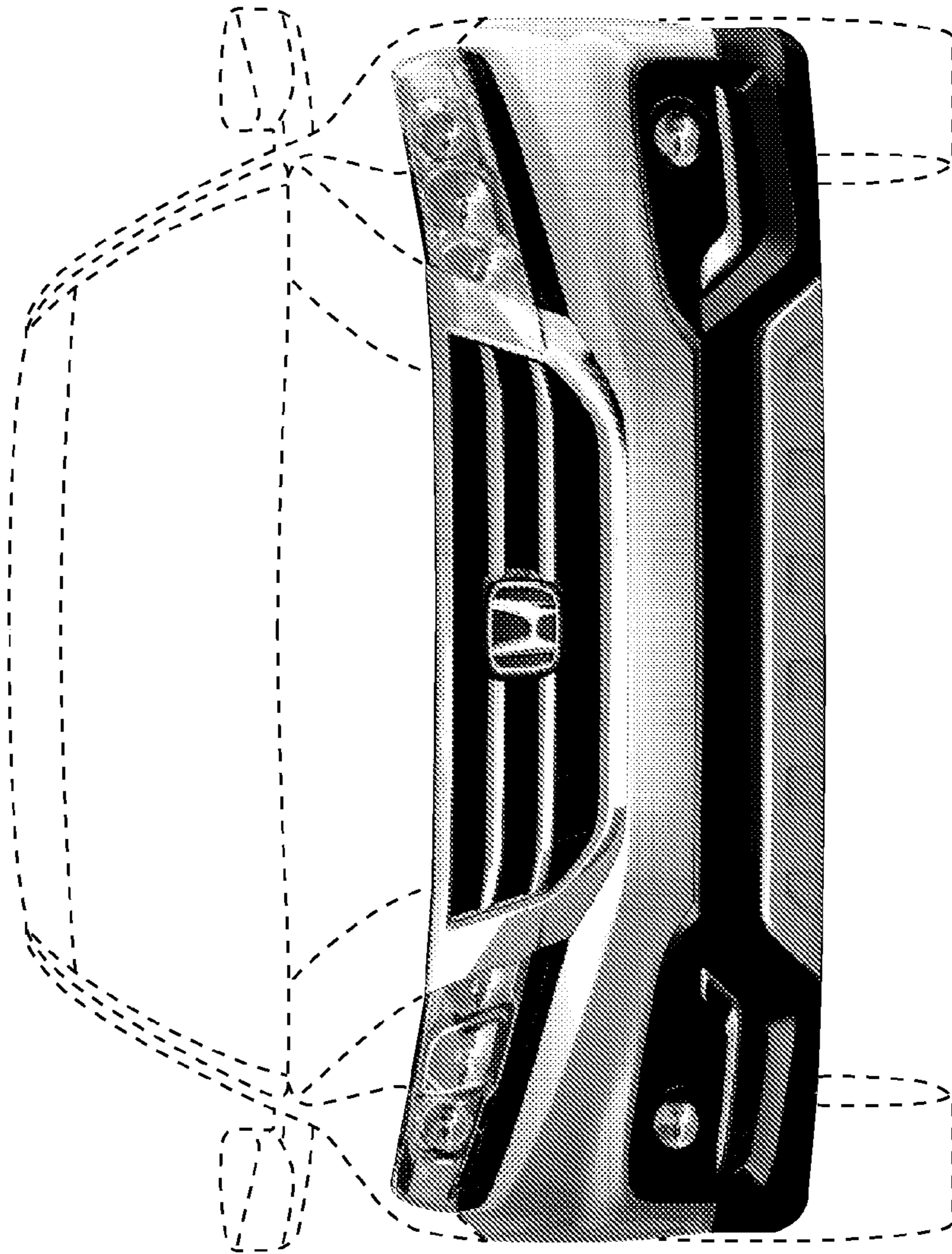

FIG. 1



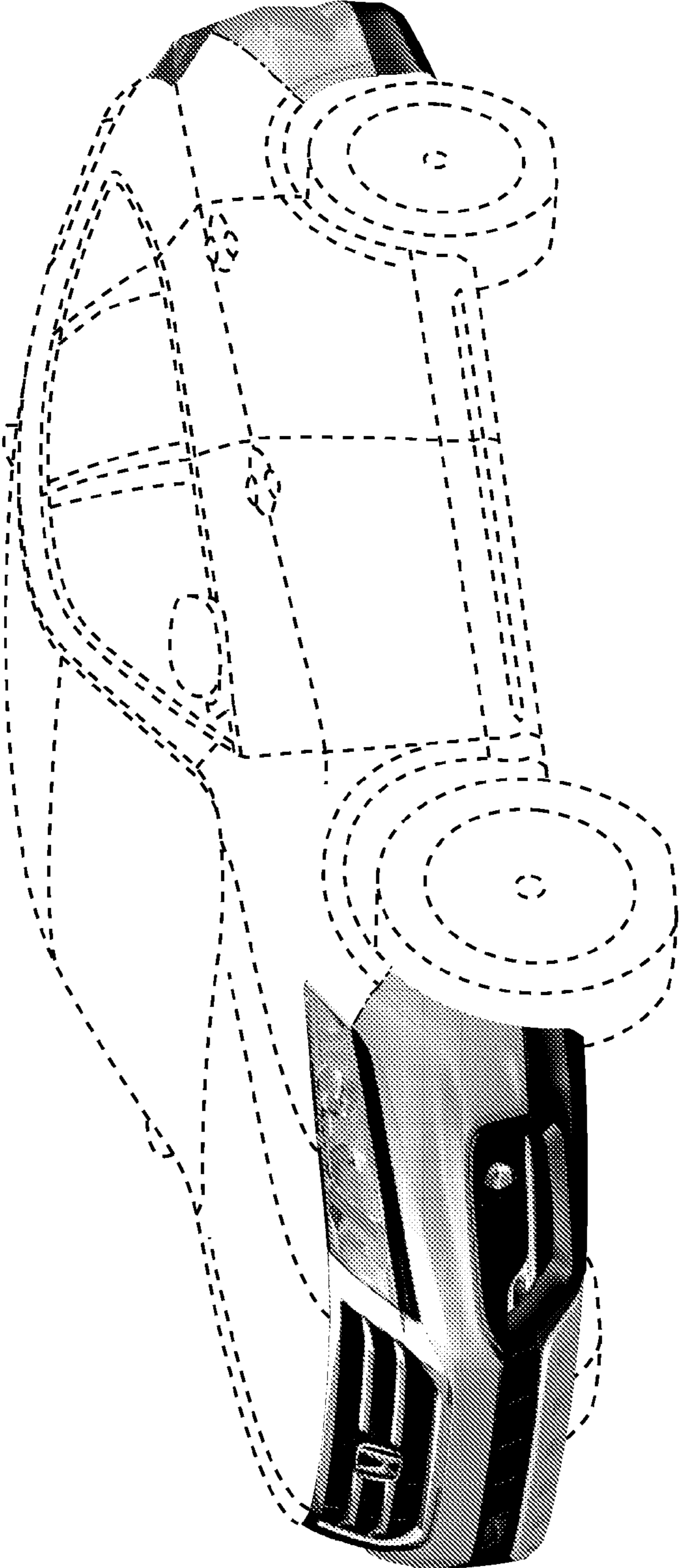

FIG. 2

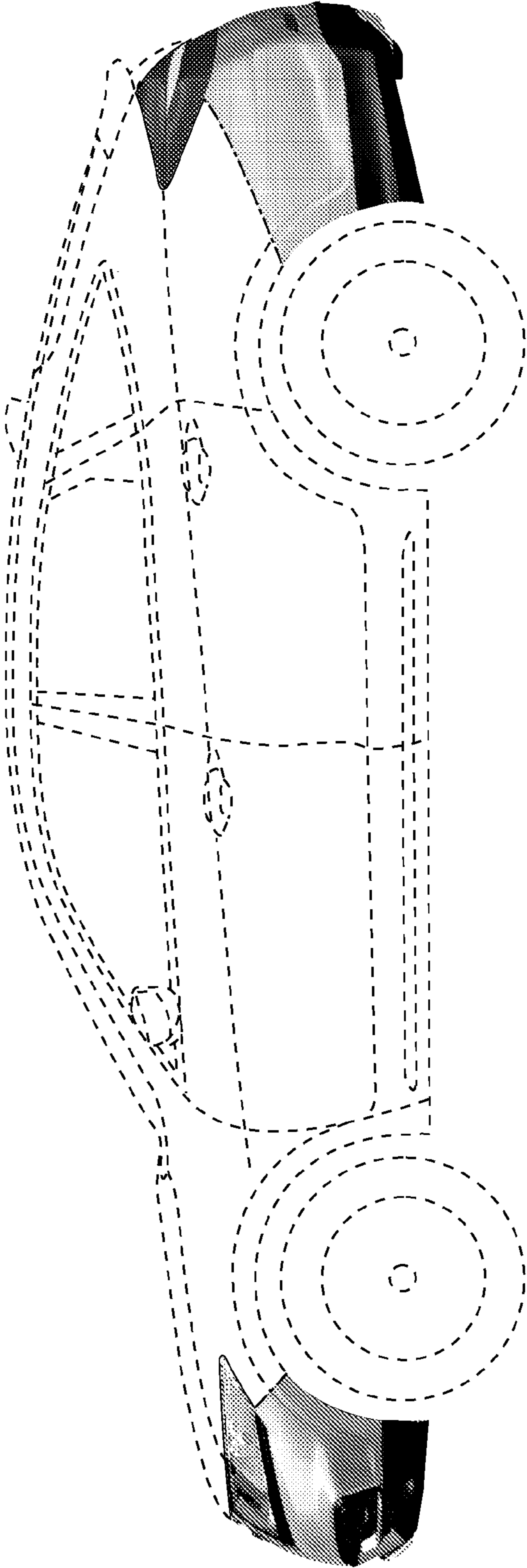

FIG. 3

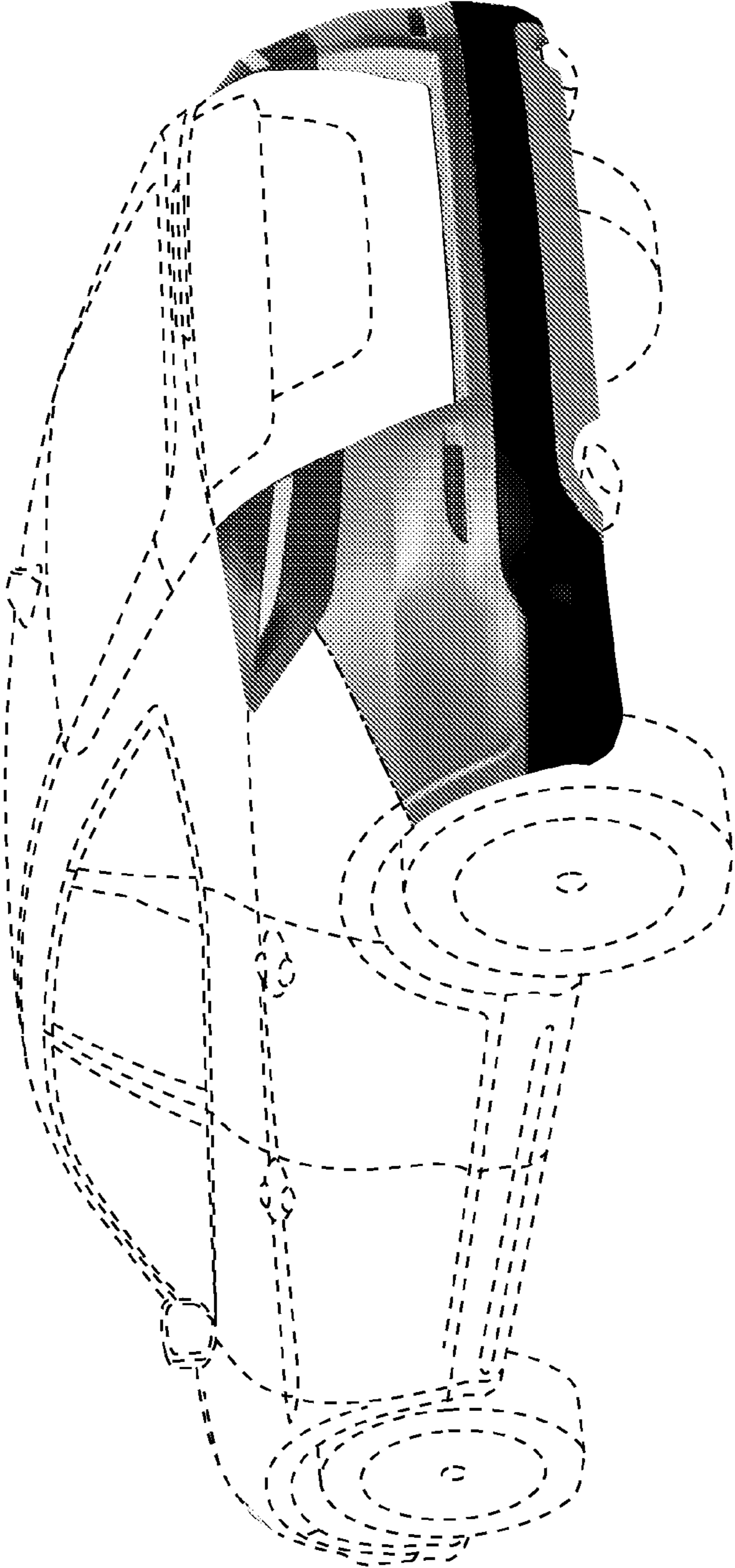

FIG. 4

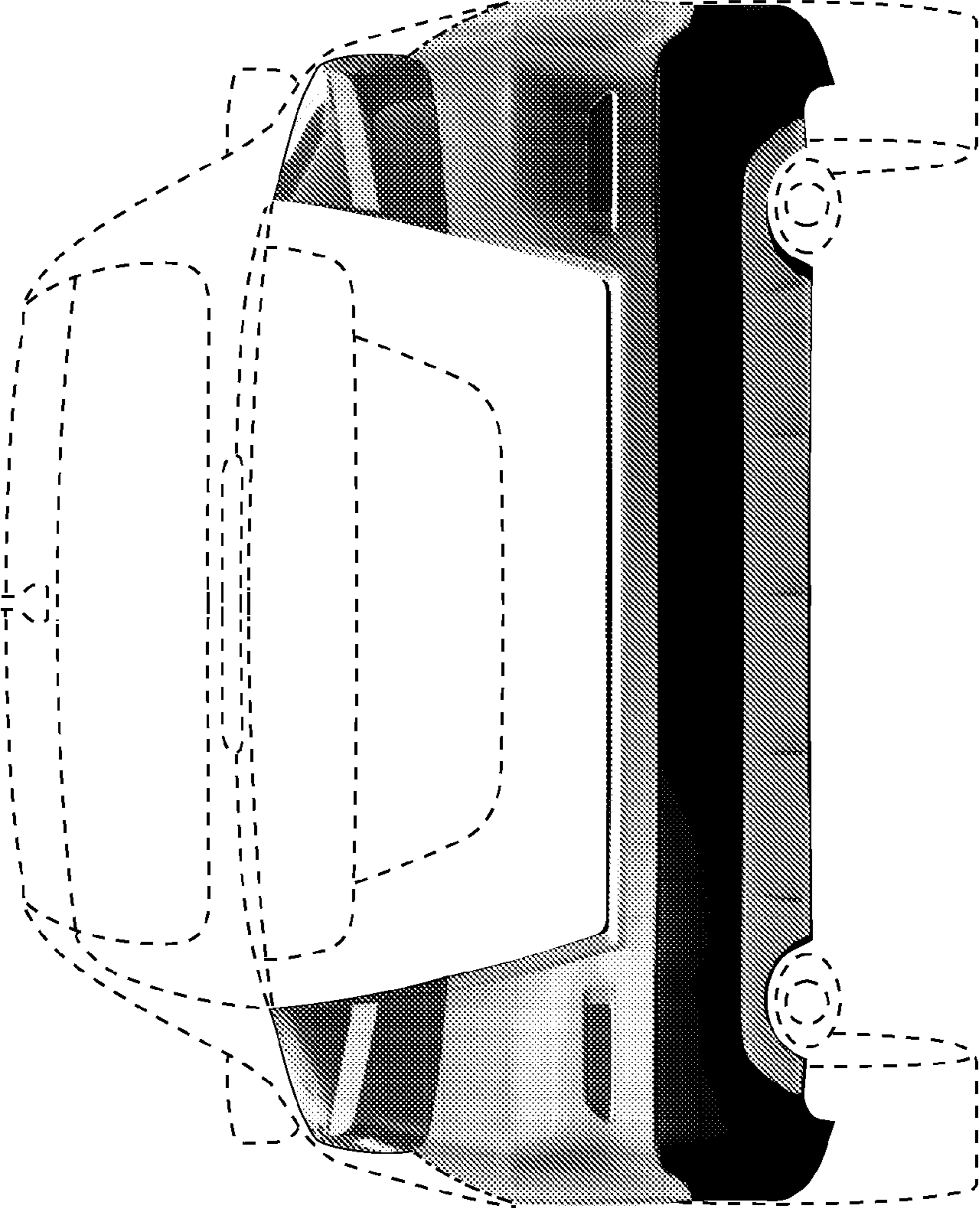

FIG. 5



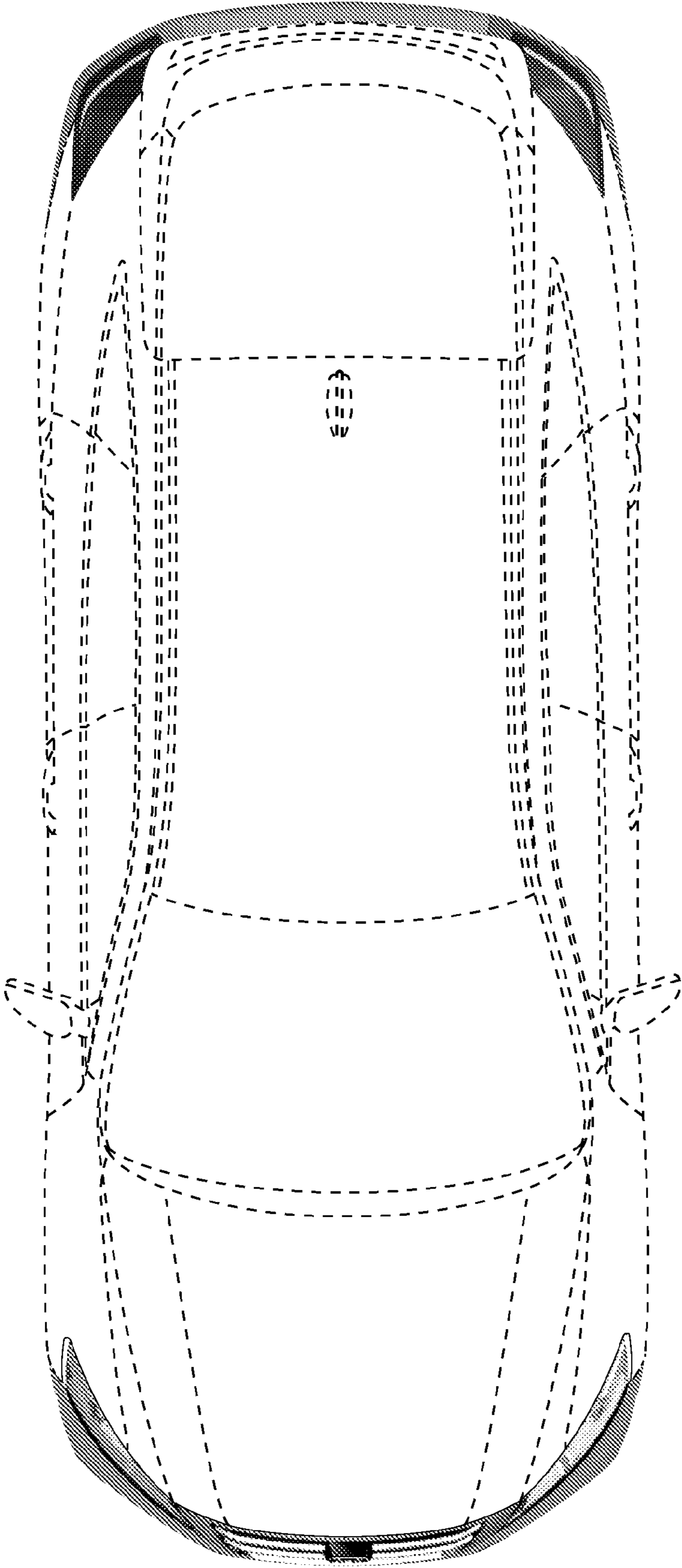

FIG. 6