



US00D690004S

(12) **United States Design Patent**
Pruitt et al.

(10) **Patent No.:** **US D690,004 S**
(45) **Date of Patent:** **** Sep. 17, 2013**

(54) **HOLDER FOR A DEVICE FOR DELIVERING CELLULAR MATERIAL AND PHYSIOLOGIC FLUIDS**

FOREIGN PATENT DOCUMENTS

EP 971679 6/2002
EP 1702632 9/2006

(Continued)

(75) Inventors: **Terrell Pruitt**, Lawrenceville, GA (US); **Yandong Su**, Atlanta, GA (US); **Bryan Marshall**, Atlanta, GA (US); **Stephen Cochran**, Tucker, GA (US); **Joseph Suarez**, Plantation, FL (US)

OTHER PUBLICATIONS

Atala, (2004) Tissue engineering and regenerative medicine: concepts for clinical application. *Rejuvenation Res* 7:15 31.

(Continued)

(73) Assignee: **Aderans Research Institute, Inc.**, Marietta, GA (US)

Primary Examiner — David Muller

(74) *Attorney, Agent, or Firm* — Pabst Patent Group LLP

(**) Term: **14 Years**

(57) **CLAIM**

The ornamental design for a holder for a device for delivering cellular material and physiologic fluids, as shown and described.

(21) Appl. No.: **29/415,973**

DESCRIPTION

(22) Filed: **Mar. 16, 2012**

(51) **LOC (9) Cl.** **24-02**

(52) **U.S. Cl.**
USPC **D24/113**

(58) **Field of Classification Search**
USPC D24/112–114, 133, 130, 127, 128;
606/181, 185; 604/232, 187, 158, 164.08,
604/192, 263, 163, 181, 184, 198, 227
See application file for complete search history.

FIG. 1 is a top, right, front isometric view of a holder for use in a device for delivering cellular material and physiologic fluids showing our new design;
FIG. 2 is a bottom, left, rear isometric view;
FIG. 3 is a front elevational view;
FIG. 4 is a right side elevational view;
FIG. 5 is a rear elevational view;
FIG. 6 is a left side elevational view;
FIG. 7 is a top plan view;
FIG. 8 is a bottom plan view;
FIG. 9 is a top, right, front isometric view of the holder in a device for delivering cellular material and physiologic fluids that includes a micrometer and syringe and needle assembly, shown in broken lines;
FIG. 10 is a rear elevational view of the holder in the device; and,
FIG. 11 is a bottom plan view of the holder in the device.
The broken lines depict environmental structure only and form no part of the claimed design.

(56) **References Cited**

U.S. PATENT DOCUMENTS

1,556,085	A	10/1925	DePew
2,472,116	A	6/1949	Maynes
2,660,342	A	11/1953	Herman
2,853,070	A	9/1958	Julliard
3,596,292	A	8/1971	Erb
3,799,406	A	3/1974	St. John
4,357,971	A	11/1982	Friedman
4,458,678	A	7/1984	Yannas
4,659,327	A	4/1987	Bennett

(Continued)

1 Claim, 10 Drawing Sheets

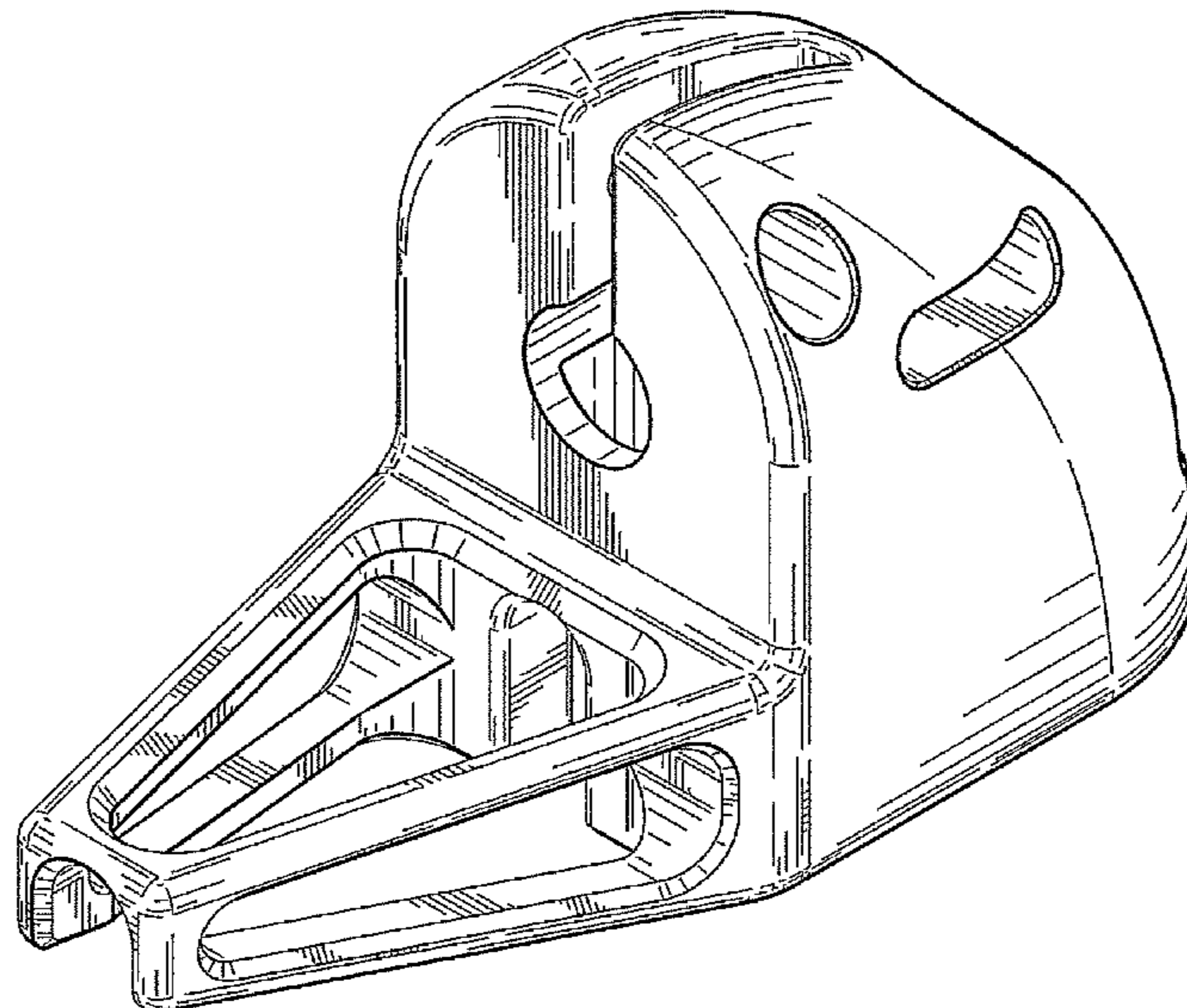

(56)

References Cited

U.S. PATENT DOCUMENTS

5,219,099	A	6/1993	Spence	
5,376,542	A	12/1994	Schlegal	
5,423,778	A	6/1995	Eriksson	
5,505,704	A	4/1996	Pawelka	
3,281,023	A	10/1996	Bruck	
5,611,811	A	3/1997	Goldberg	
5,697,901	A	12/1997	Eriksson	
5,817,120	A	10/1998	Rassman	
5,957,896	A	9/1999	Bendek	
5,989,279	A	11/1999	Rassman	
5,993,374	A	11/1999	Kick	
5,997,468	A	12/1999	Wolff	
6,027,744	A	2/2000	Vacanti	
6,062,753	A	5/2000	Hadtke	
D452,313	S *	12/2001	Niermann	D24/112
6,387,077	B1	5/2002	Klibanov	
6,402,770	B1 *	6/2002	Jessen	606/185
6,474,344	B2	11/2002	Yamada	
6,569,143	B2	5/2003	Alchas	
6,660,301	B1	12/2003	Vogel	
6,793,646	B1	9/2004	Giambattista	
6,884,427	B1	4/2005	Barrows	
6,890,319	B1	5/2005	Crocker	
7,198,641	B2	4/2007	Barrows	
7,534,222	B2	5/2009	Sugita	
D609,338	S *	2/2010	Dozier, Jr.	D24/130
D613,859	S *	4/2010	Bierman	D24/130
D614,296	S *	4/2010	Young	D24/130
D618,796	S *	6/2010	Cantu et al.	D24/133
D620,591	S *	7/2010	Young	D24/130
D622,841	S *	8/2010	Bierman	D24/130
7,771,390	B2	8/2010	Brown	
7,780,635	B2	8/2010	Pruitt	
D642,261	S *	7/2011	York et al.	D24/130
D651,309	S *	12/2011	Rowe et al.	D24/130
D659,825	S *	5/2012	Dillard, III	D24/130
D660,418	S *	5/2012	Kuczek et al.	D24/130
8,206,335	B2	6/2012	Pruitt	
8,251,950	B2 *	8/2012	Albert et al.	604/110
2002/0159982	A1	10/2002	Bonassar	
2002/0172705	A1	11/2002	Murphy	
2002/0193740	A1	12/2002	Alchas et al.	
2003/0009113	A1	1/2003	Olson	
2003/0147831	A1	8/2003	Marko	
2003/0161815	A1	8/2003	Wolowacz	
2003/0198646	A1	10/2003	Stenn	
2003/0211083	A1	11/2003	Vogel	
2003/0235813	A1	12/2003	Luyten	
2004/0068284	A1	4/2004	Barrows	
2004/0096514	A1	5/2004	Vogel	
2004/0220589	A1	11/2004	Feller	
2005/0089512	A1	4/2005	Schlotmann	
2005/0147652	A1	7/2005	Atkins	
2005/0214344	A1	9/2005	Barrows	
2005/0233450	A1	10/2005	Goetinck	
2006/0057126	A1	3/2006	Tankovich	
2006/0062770	A1	3/2006	Zheng	
2006/0206057	A1	9/2006	Deruntz	
2007/0092496	A1	4/2007	Zheng	
2007/0122387	A1	5/2007	Cochran	
2007/0191784	A1	8/2007	Jacobs	
2012/0283656	A1	11/2012	Pruitt	

FOREIGN PATENT DOCUMENTS

FR	667350	10/1929
FR	1318748	2/1963
FR	2770136	4/1999
JP	2001302520	10/2001
JP	2003235990	8/2003
TW	445157	7/2001
WO	9901034	1/1999
WO	0009184	2/2000
WO	0045736	10/2000
WO	0166472	9/2001
WO	0170132	9/2001

WO	0170289	9/2001
WO	0170290	9/2001
WO	0170291	9/2001
WO	0174164	10/2001
WO	02060396	8/2002
WO	02083216	10/2002
WO	03011372	2/2003
WO	03068248	8/2003
WO	03088935	10/2003
WO	2005018731	3/2005
WO	2005053763	6/2005
WO	2005097221	10/2005
WO	2006020756	2/2006
WO	2006020958	2/2006
WO	2006057542	6/2006
WO	2007047707	4/2007
WO	2007062386	5/2007
WO	2007062387	5/2007
WO	2007092929	8/2007

OTHER PUBLICATIONS

Atlas of Anatomy Barron's Educational Series, Inc., 1997, p. 72.

Barrows, et al., 'Tissue Engineered Human Hair: Preliminary Clinical Results' TE2002: International Workshop on Tissue Engineering, St. Gallen, Switzerland (Feb. 2002).

Castex-Rizzi et al., 'Implication of VEGF, steroid hormones and neuropeptides in hair follicle cell responses,' *Ann. Dermatol. Venereol.* (2002) 129(5):783-786.

Cotsarelis, et al., "Label-retaining cells reside in the bulge area of pilosebaceous unit. Implications for follicular stem cells, hair cycle and skin carcinogenesis", *Cell* 61:1329-1337 (1990).

Gho et al., "Hair transplantation of plucked hair biopsies," *Dermatol. Surg.*, 27 (10):913 (2001).

Gho et al., To Multiply or Not to Multiply, That is the Question . . . , Dr. Coen Gho presentation at the International Society of Hair Restoration Surgeons 2003 New York City Conference, Oct. 19, 2003(Abstract).

Horne, et al. 'Whisker growth induced by implantation of cultured vibrissa dermal papilla cells in the adult rat' *J Embryol Exp Morphol.*, 97:111-24 (1986).

Horne et al., 'Restoration of hair growth by surgical implantation of follicular dermal sheath,' *Development*, 116(3):563-571 (1992) Abstract.

Inamatsu et al., 'Establishment of rat dermal papilla cell lines that sustain the potency to induce hair follicles from a follicular skin' *J Invest Dermatol.*, 111 (5):767-75 (1998).

Jahoda, 'Induction of follicle formation and hair growth by vibrissa dermal papillae implanted into rat ear wounds: vibrissa-type fibres are specified', *Development*, 115(4):1103-9 (1992).

Jahoda, et al., Trans-species hair growth induction by human hair follicle dermal papillae, *Exp. Dermatol.*, 10:229-237 (2001).

Jahoda, et al., "Human Hair follicle regeneration following amputation and grafting into the nude mouse", *J Invest Dermatol.*, 107(6):804-807 (1996).

Jahoda, et al., "Induction of hair growth by implantation of cultured dermal papilla cells", *Nature*, 311(5986):560-2 (1984).

Jahoda, et al., "Induction of Hair Growth in Ear Wounds by Cultured Dermal Papilla Cells", *J Invest Dermatol.*, 101(4):584-590 (1993).

Jahoda and Reynolds, "Hair follicle dermal sheath cells: unsung participants in wound healing", *Lancet*, 358:1445-1448 (2001).

Layer, et al., "Of layers and spheres: the reaggregate approach in tissue engineering", *Trends Neurosci.*, 25:131-134 (2002).

Lee, Tissue-engineered human living skin substitutes: development and clinical application, *Yonsei Med. J.*, 41(6):774-779 (2001).

Lichti, et al., "Hair follicle development and hair growth from defined cell populations grafted onto nude mice", *J Invest Dermatol.*, 104(5):43S-44S (1995).

Lichti et al., In vivo regulation of murine hair growth: insights from grafting defined cell populations onto nude mice, *J Invest Dermatol.*, 101(1 Suppl):124S-129S (1993).

Magerl, et al., "Simple and rapid method to isolate and culture follicular papillae from human hair follicles", *Exp. Dermatol.*, 11:381-385 (2002).

Matsuzaki, et al., "The upper dermal sheath has a potential to regenerate the hair in the rat follicular epidermis", *Differentiation*, 60(5):287-297 Abstract (1996).

Mayorov, et al., "B2 elements present in the human genome", *Mamm. Genome*, 11:177-179 (2000).

McElwee, et al., "Cultured Peribulbar Dermal Sheath Cells Can Induce Hair Follicle Development and Contribute to the Dermal Sheath and Dermal Papilla", *J. Invest Dermatol*, 121:1267-1275 (2003).

Michel, et al., "Characterization of a new tissue-engineered human skin equivalent with hair", *In Vitro Cell Dev Biol. Anim.*, 35(6):318-326 (1999).

Price, "Treatment of Hair Loss", *N Eng J Med*, 341:964-973 (1999).

Rassman, et al., "Rapid fire hair implanter carousel", *Dermatologic Surgery*, 24:623-627 (1998).

Remmler, et al., "Use of injectable cultured human fibroblasts for percutaneous tissue implantation", *Arch Otolaryngol Head Neck Surg*, 115:837-844 (1989).

Stenn, et al., 'Growth of the Hair Follicle: A Cycling and Regenerating Biological System,' *The Molecular Basis of Epithelial Appendage Morphogenesis*, ed. C-M Chuong, Landes Publ. Austin TX (1998) 111-130.

Stenn, et al., "Hair follicle growth controls", *Dermatol Clinics*, 14:543-558 (1996).

Stenn and Cotsarelis, "Bioengineering the hair follicle: fringe benefits of stem cell technology", *Curr. Opin. In Biotech.*, 16:1-5 (2005).

Worst, et al., 'Reformation of organized epidermal structure by transplantation of suspensions and cultures of epidermal and dermal cells,' *Cell Tiss. Res.* (1982) 225(1):65-77 (1982).

Yang, et al., "Cell sheet engineering: recreating tissue without biodegradable scaffolds", *Biomaterials*, 26(33):6415-6422 (2005).

* cited by examiner

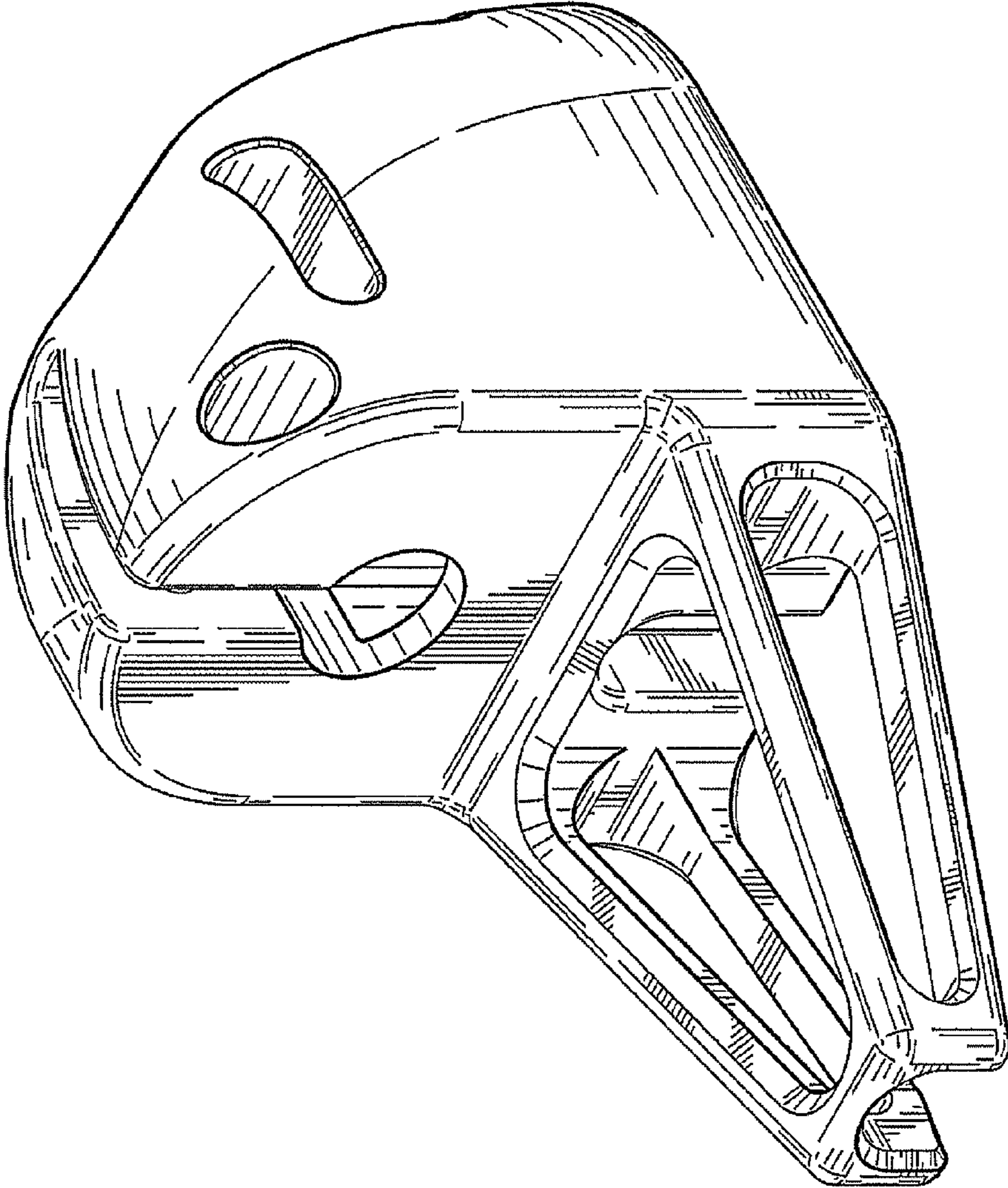

FIG. 1

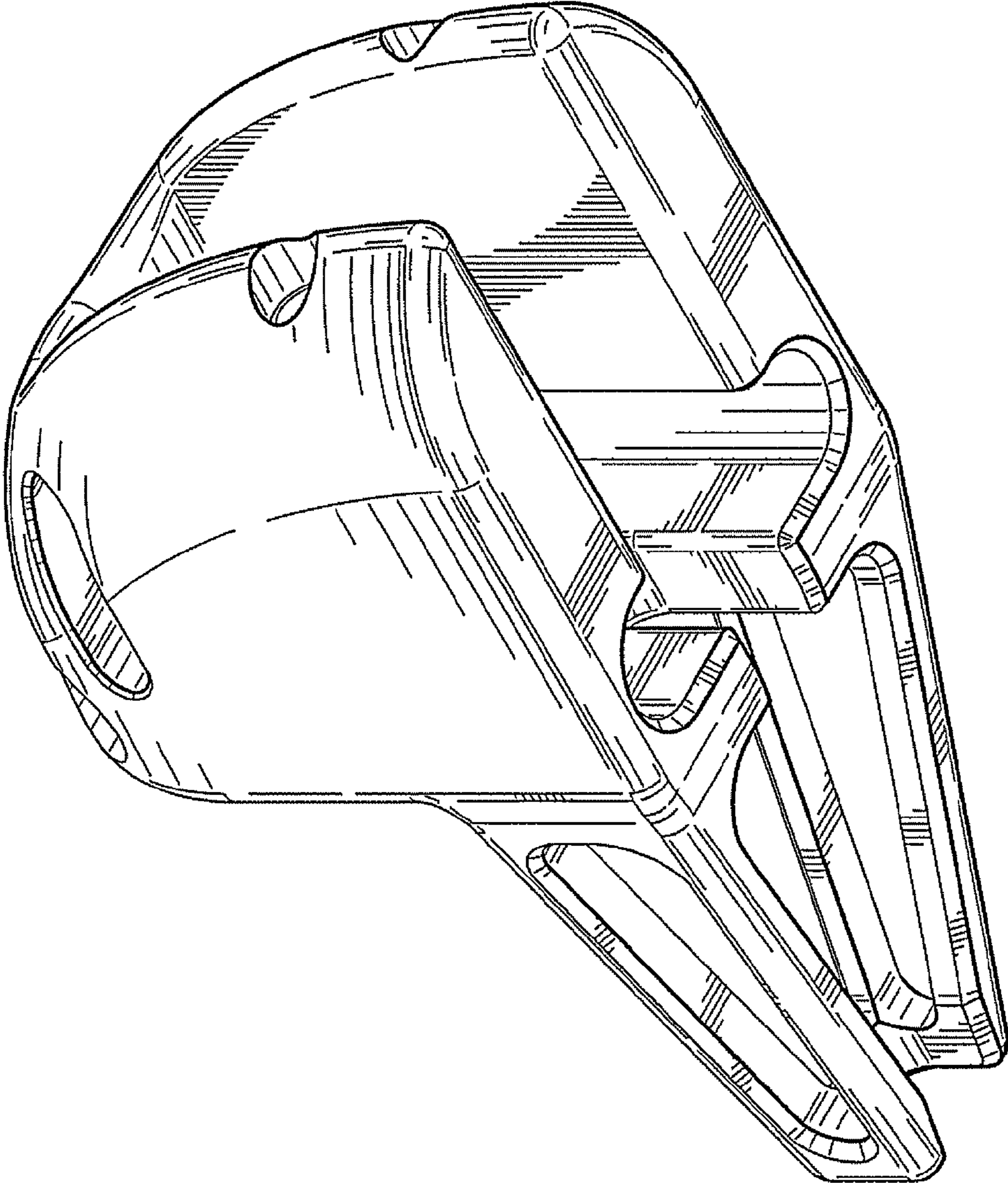

FIG. 2

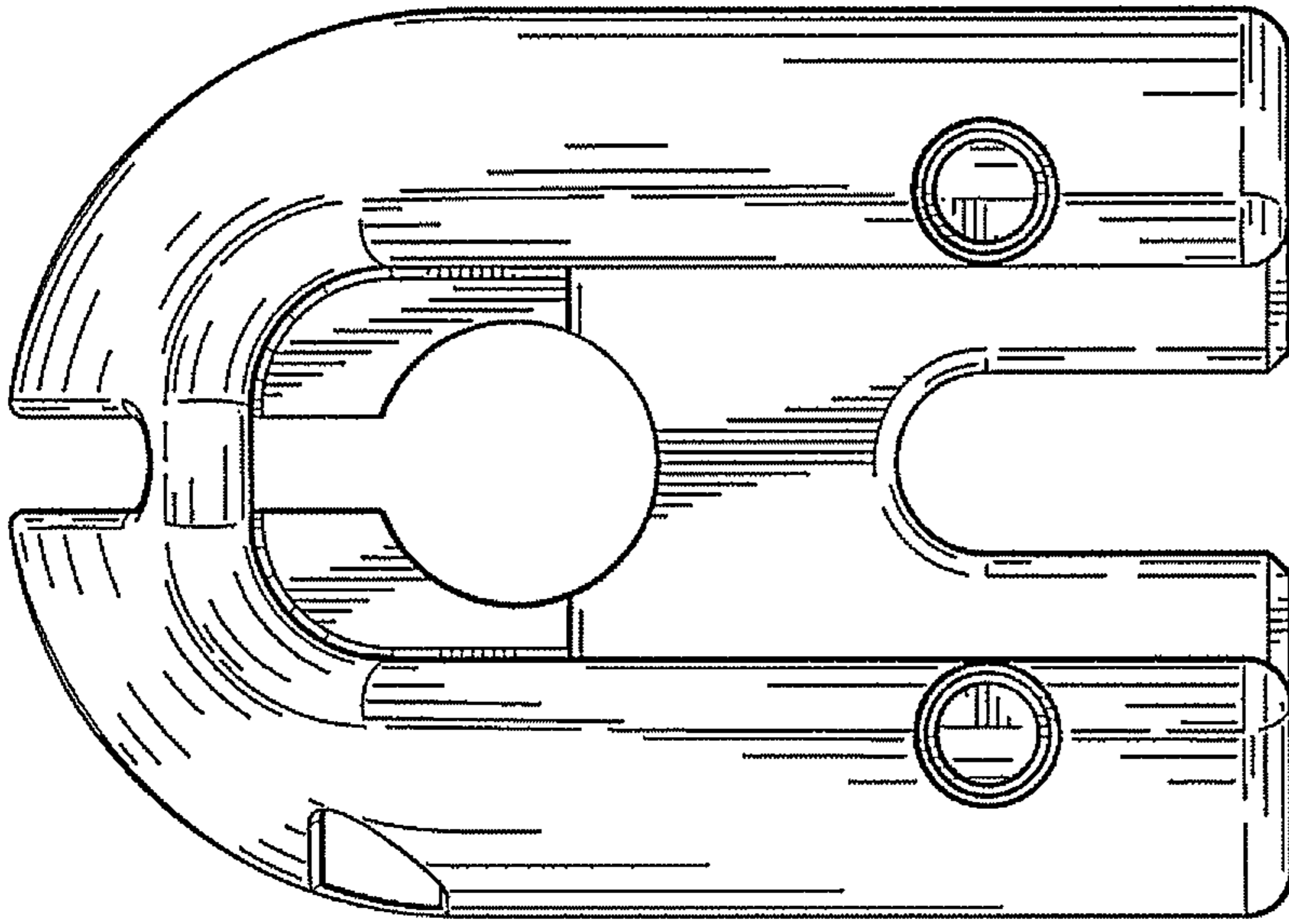

FIG. 5

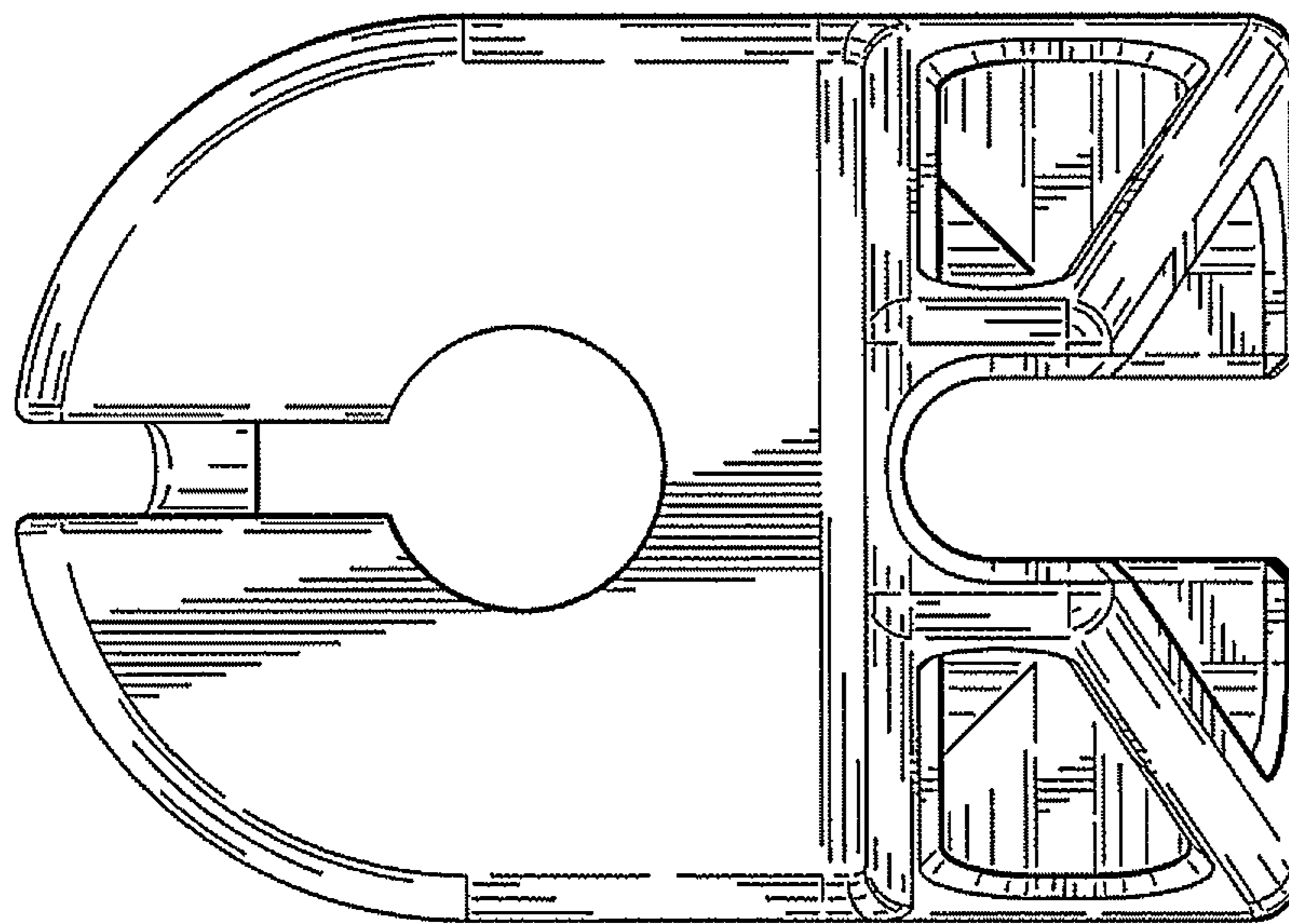

FIG. 3

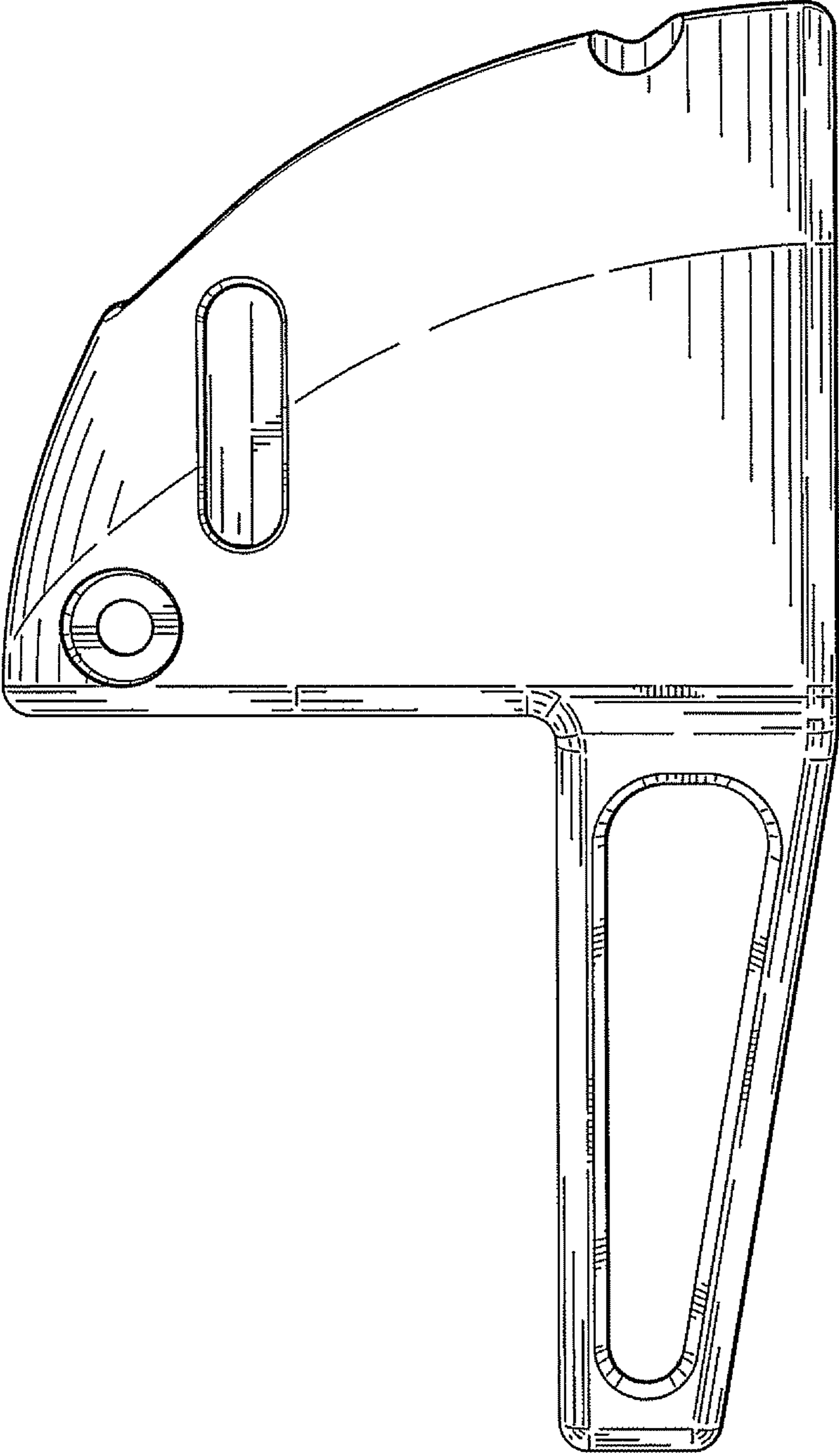

FIG. 4

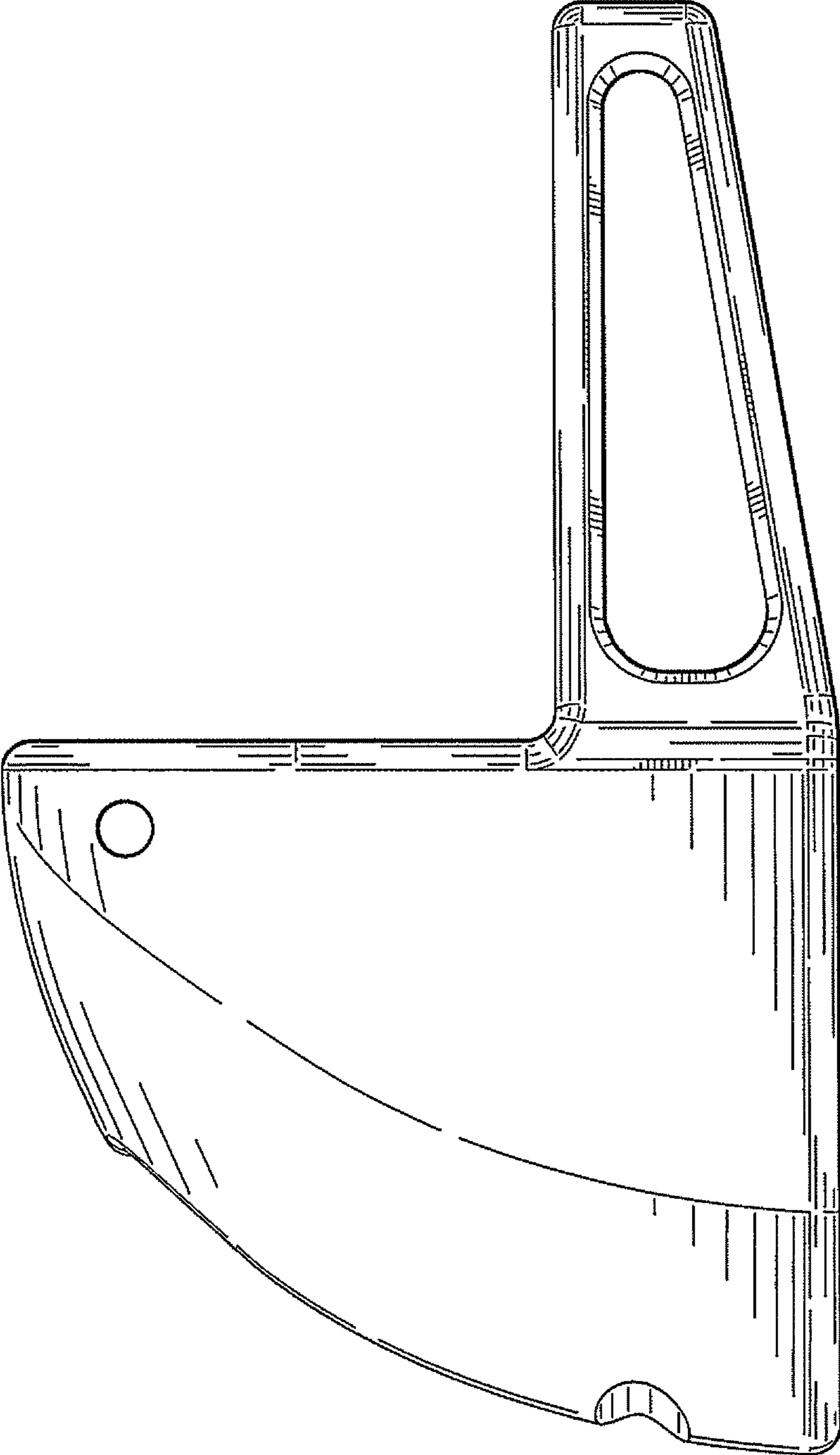

FIG. 6

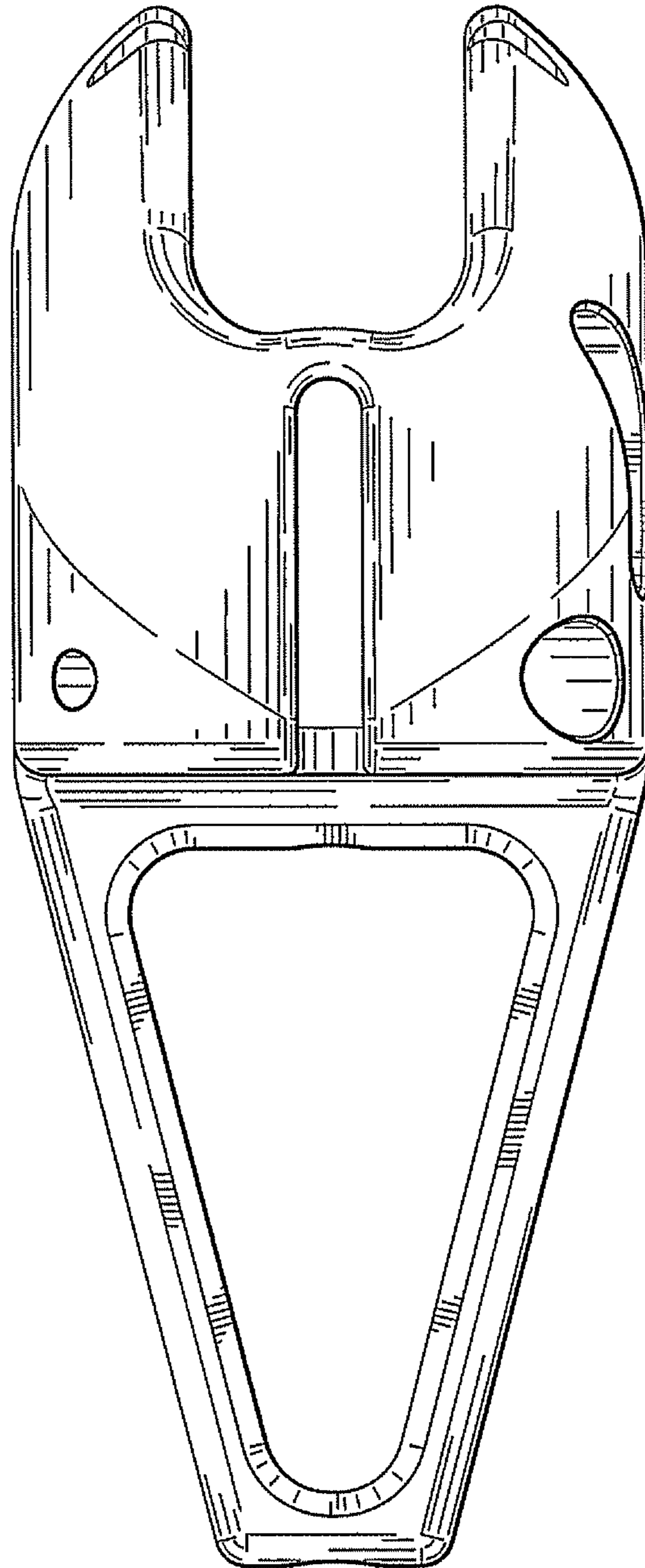

FIG. 7

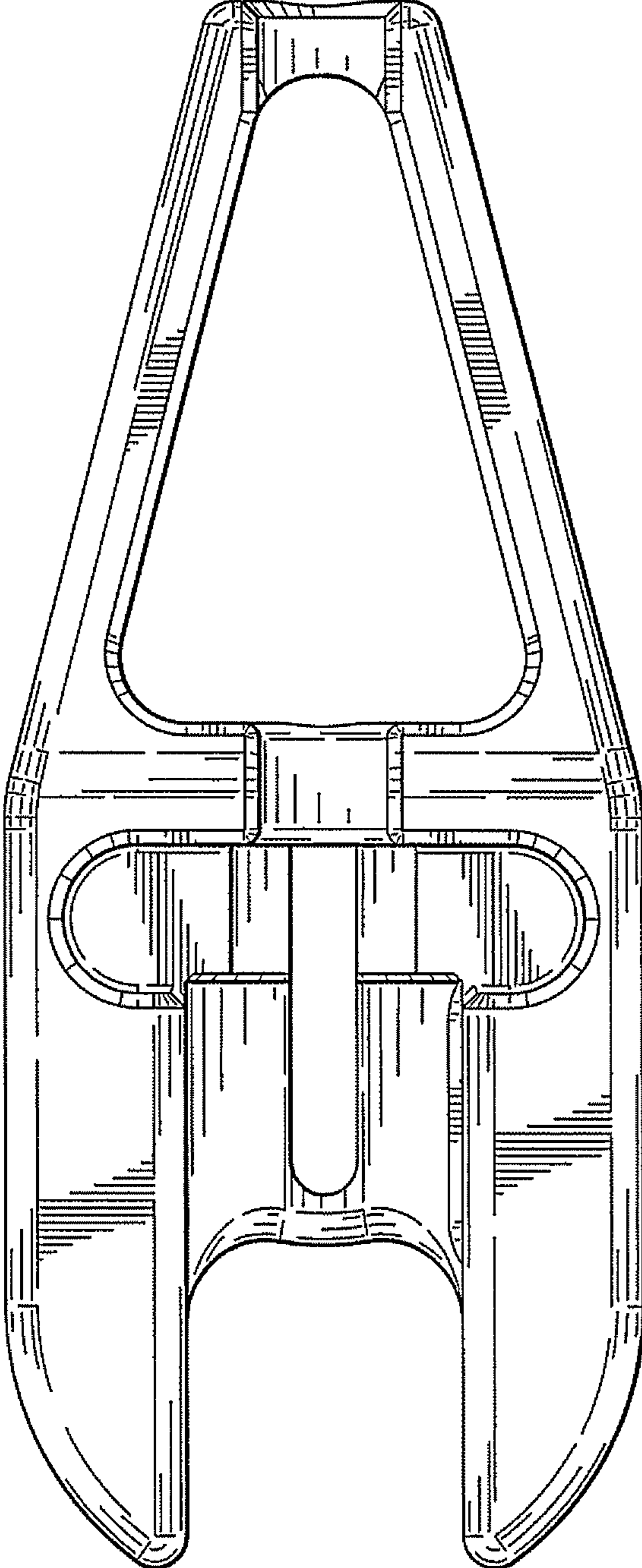

FIG. 8

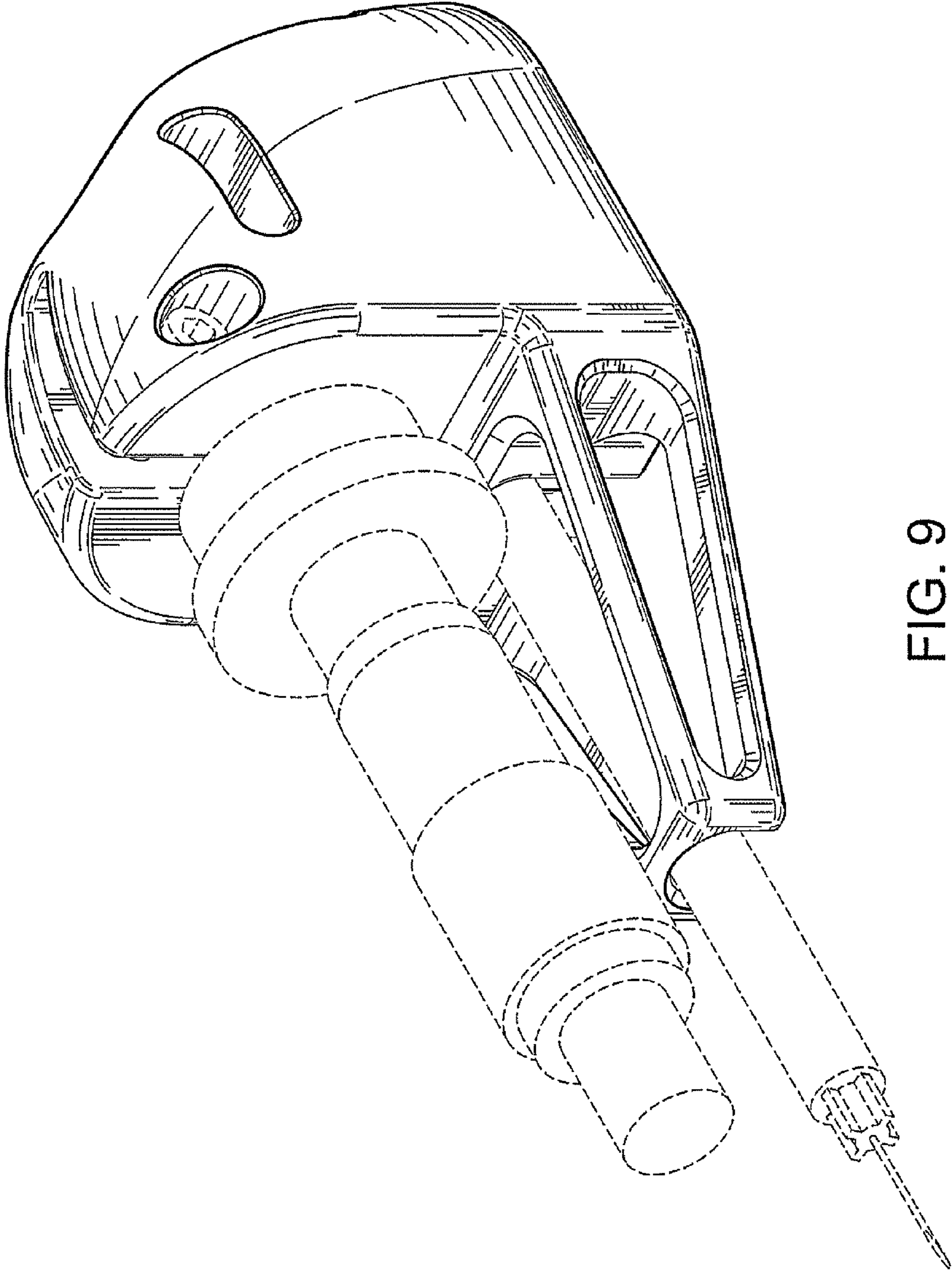

FIG. 9

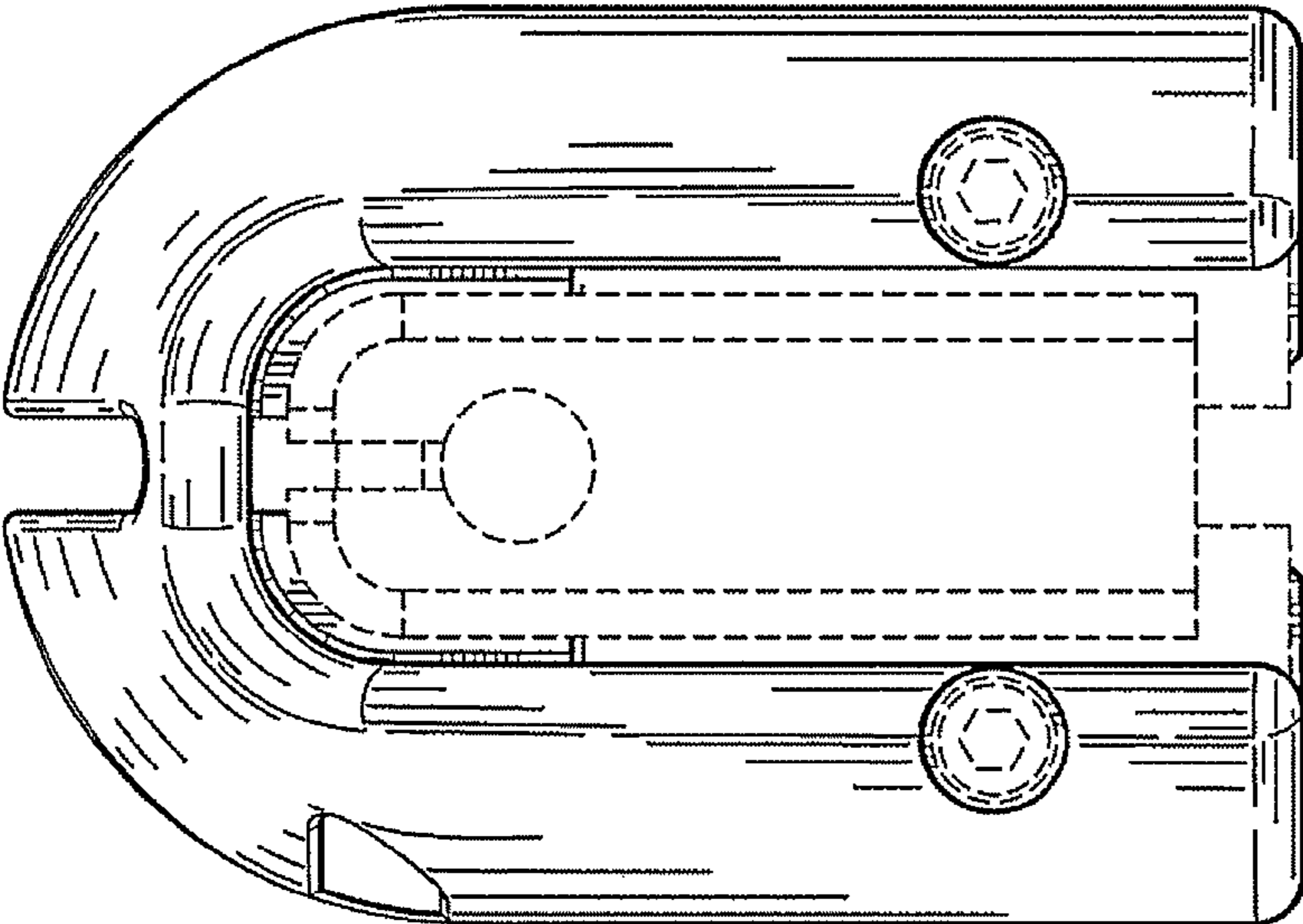

FIG. 10

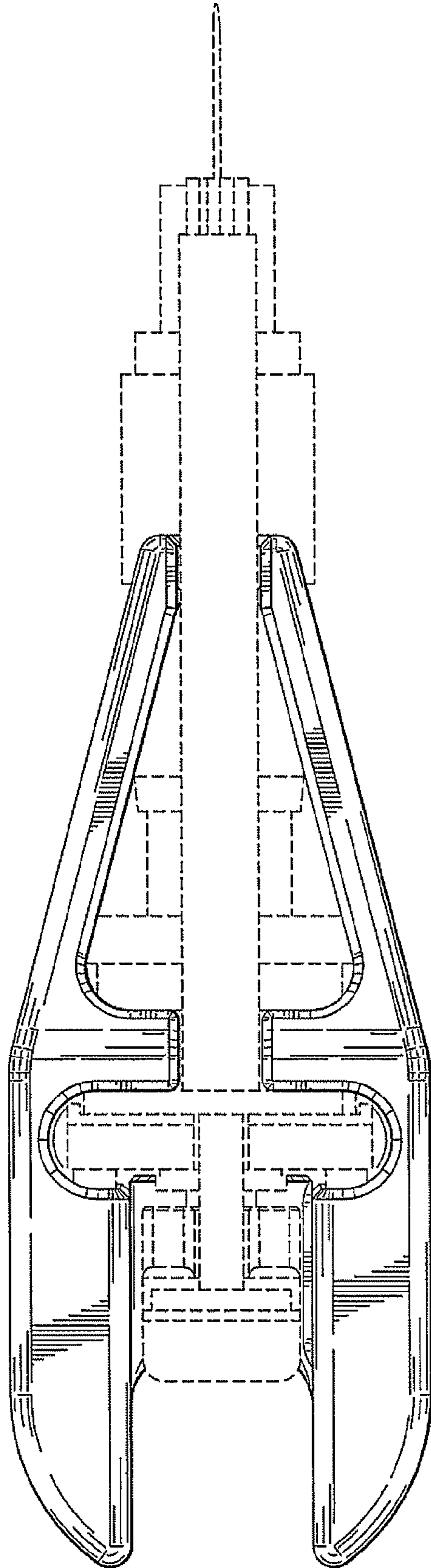

FIG. 11