

US00D689397S

(12) **United States Design Patent**
Koyama et al.

(10) **Patent No.:** **US D689,397 S**
(45) **Date of Patent:** **** Sep. 10, 2013**

- (54) **MOTOR VEHICLE AND/OR TOY REPLICA THEREOF**
- (71) Applicant: **Toyota Jidosha Kabushiki Kaisha, Toyota (JP)**
- (72) Inventors: **Hideo Koyama, Kariya (JP); Shun Kawaguchi, Kariya (JP)**
- (73) Assignee: **Toyota Jidosha Kabushiki Kaisha (JP)**
- (**) Term: **14 Years**
- (21) Appl. No.: **29/445,556**
- (22) Filed: **Feb. 13, 2013**

- D610,039 S * 2/2010 Koide et al. D12/90
- D617,684 S 6/2010 Nagura et al.
- D619,047 S * 7/2010 Foster D12/91
- D619,500 S 7/2010 Hsu et al.
- D624,850 S 10/2010 Yagi et al.
- D628,938 S 12/2010 Yamazaki et al.
- D630,553 S 1/2011 Muller
- D630,554 S 1/2011 Kim
- D633,008 S * 2/2011 Nakamura et al. D12/90
- D633,823 S 3/2011 Matei et al.
- D642,093 S 7/2011 Kubo et al.
- D647,428 S * 10/2011 Ohhashi et al. D12/90
- D654,399 S 2/2012 Kumai et al.
- D655,648 S 3/2012 Imaiida et al.
- D657,716 S 4/2012 Cartabiano et al.

Related U.S. Application Data

- (62) Division of application No. 29/394,409, filed on Jun. 16, 2011.

Foreign Application Priority Data

- Dec. 20, 2010 (JP) 2010-030369
- Dec. 20, 2010 (JP) 2010-030374
- Dec. 20, 2010 (JP) 2010-030376
- Dec. 20, 2010 (JP) 2010-030379

- (51) **LOC (9) Cl.** **12-08**
- (52) **U.S. Cl.**
USPC **D12/90**
- (58) **Field of Classification Search**
USPC D12/86, 90-92; D21/424, 433, 434;
296/181.1, 181.5
See application file for complete search history.

(56) **References Cited**

U.S. PATENT DOCUMENTS

- D595,615 S 7/2009 Nagafuchi et al.
- D608,694 S 1/2010 Okue et al.

OTHER PUBLICATIONS

Toyota, Toyota FT-86 GSports Concept, NetCarShow.com, http://www.netcarshow.com/toyota/2010-ft-86g_sports_concept/, Oct. 11, 2010.

(Continued)

Primary Examiner — Melody Brown

(74) *Attorney, Agent, or Firm* — Saidman DesignLaw Group

(57) **CLAIM**

The ornamental design for a motor vehicle and/or toy replica thereof, as shown and described.

DESCRIPTION

FIG. 1 is a left, front perspective view of a motor vehicle and/or toy replica thereof showing our new design;
 FIG. 2 is a left, rear perspective view thereof;
 FIG. 3 is a left side elevation thereof, the right side view being a mirror image thereof;
 FIG. 4 is a top plan view thereof;
 FIG. 5 is a front elevation view thereof; and,
 FIG. 6 is a rear elevation view thereof.
 The broken lines illustrate environmental structure and form no part of the claimed design.

1 Claim, 3 Drawing Sheets

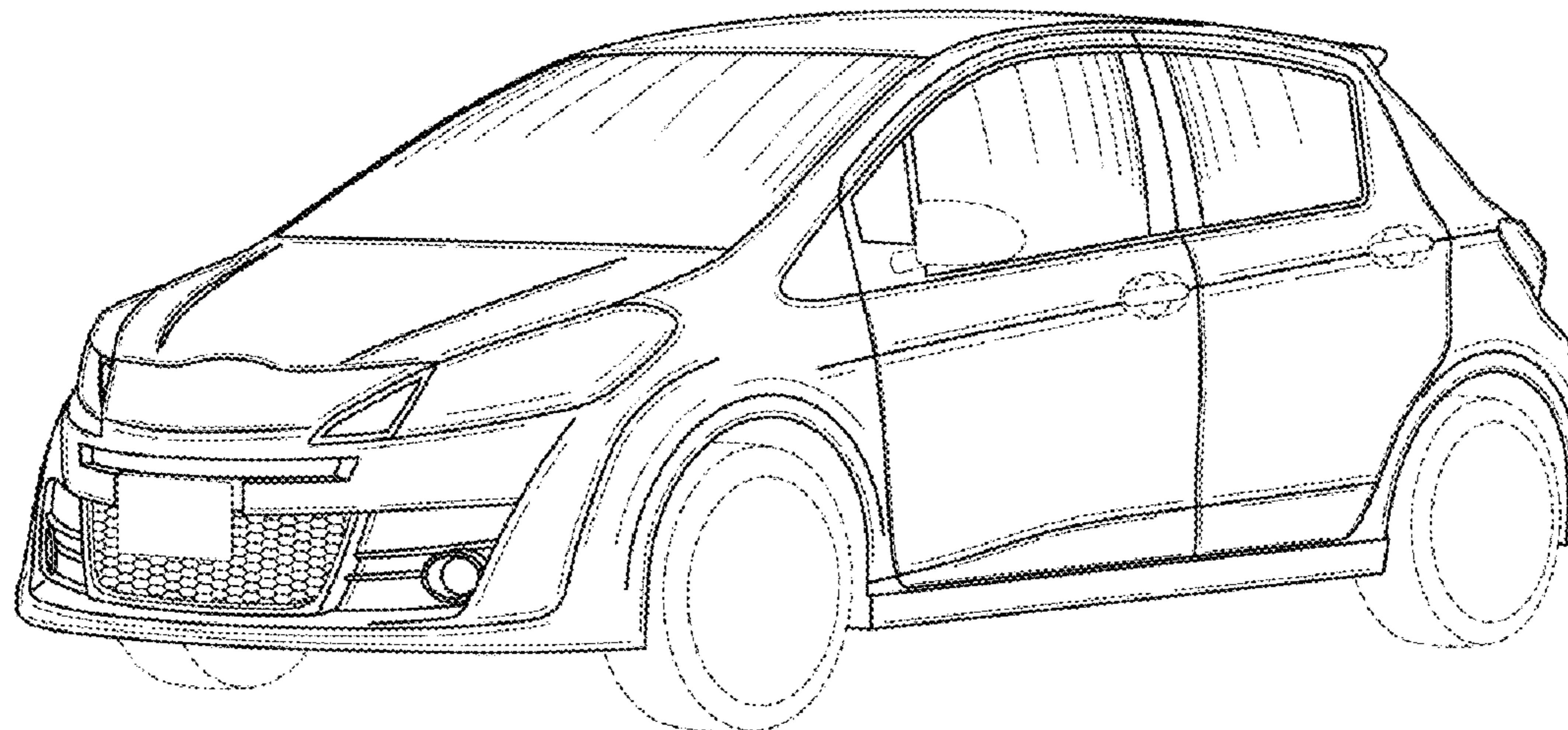

(56)

References Cited

OTHER PUBLICATIONS

Fiat, Fiat-500 Abarth, NetCarShow.com, http://www.netcarshow.com/fiat/2009-500_abarth/, available at least as early as Jun. 16, 2011.

Subaru, Subaru Impreza WRX STi, NetCarShow.com, http://www.netcarshow.com/subaru/2008-impreza_wrx_sti/, available at least as early as Jun. 16, 2011.

* cited by examiner

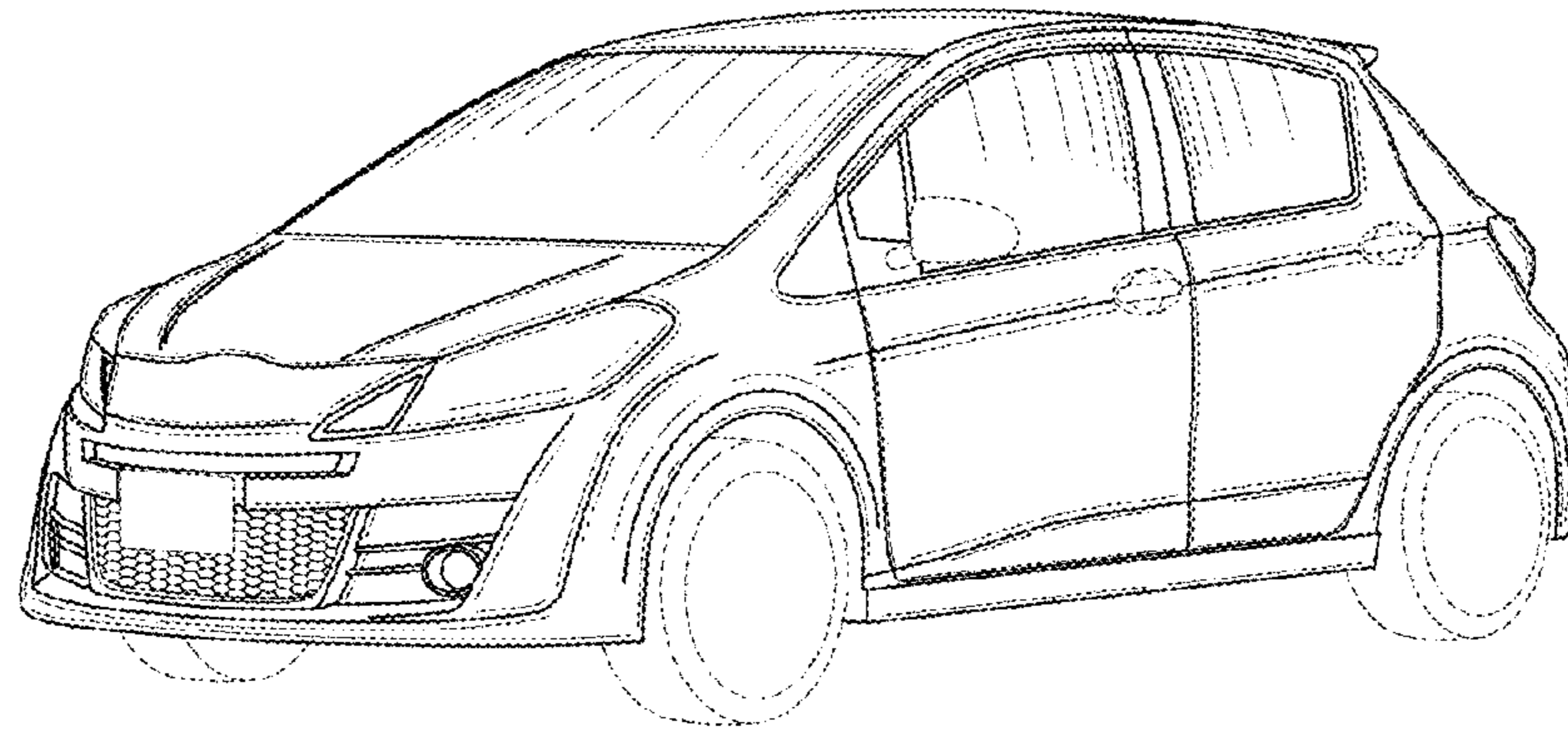

FIG. 1

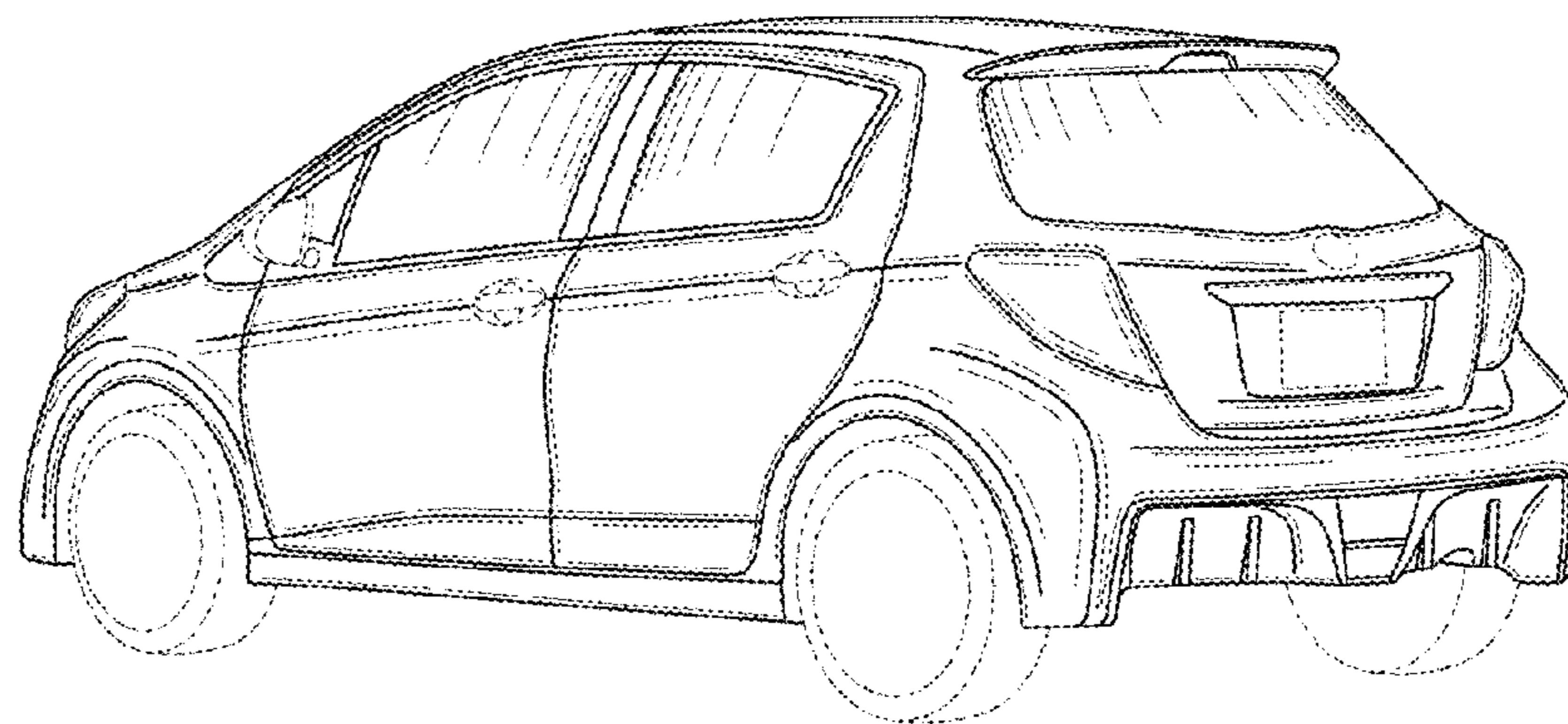

FIG. 2

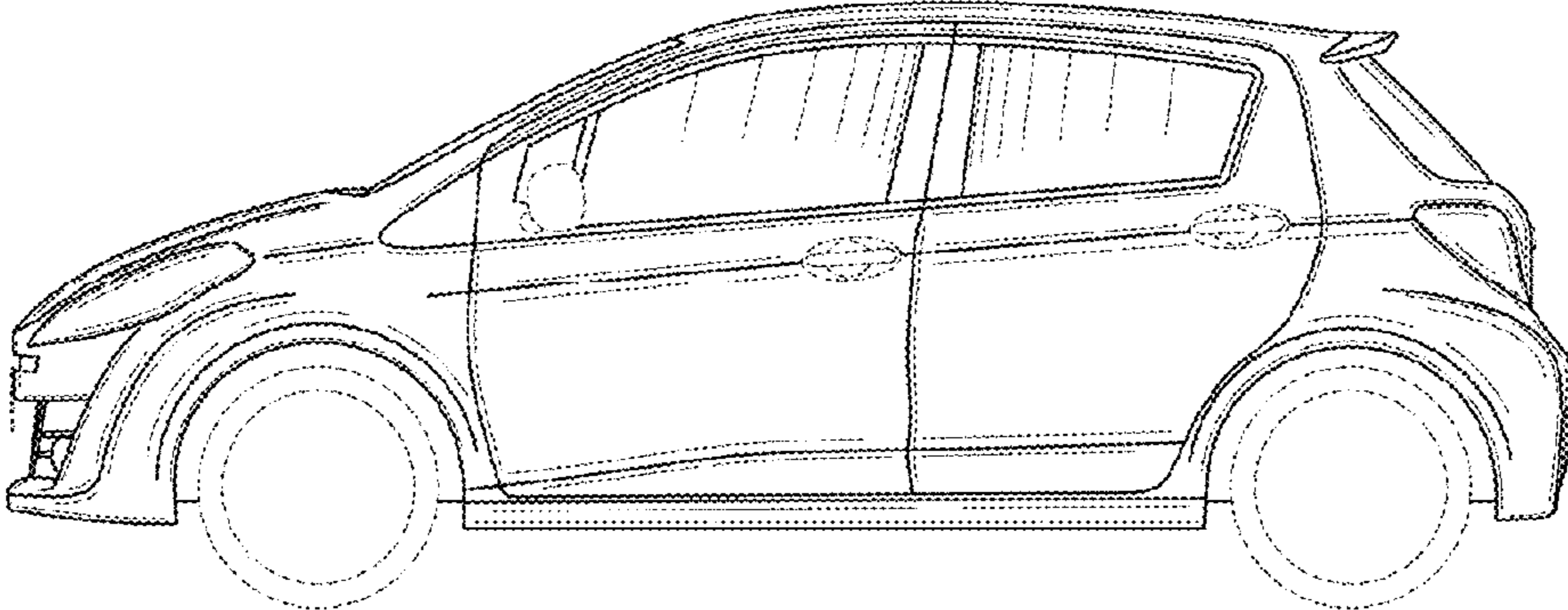

FIG. 3

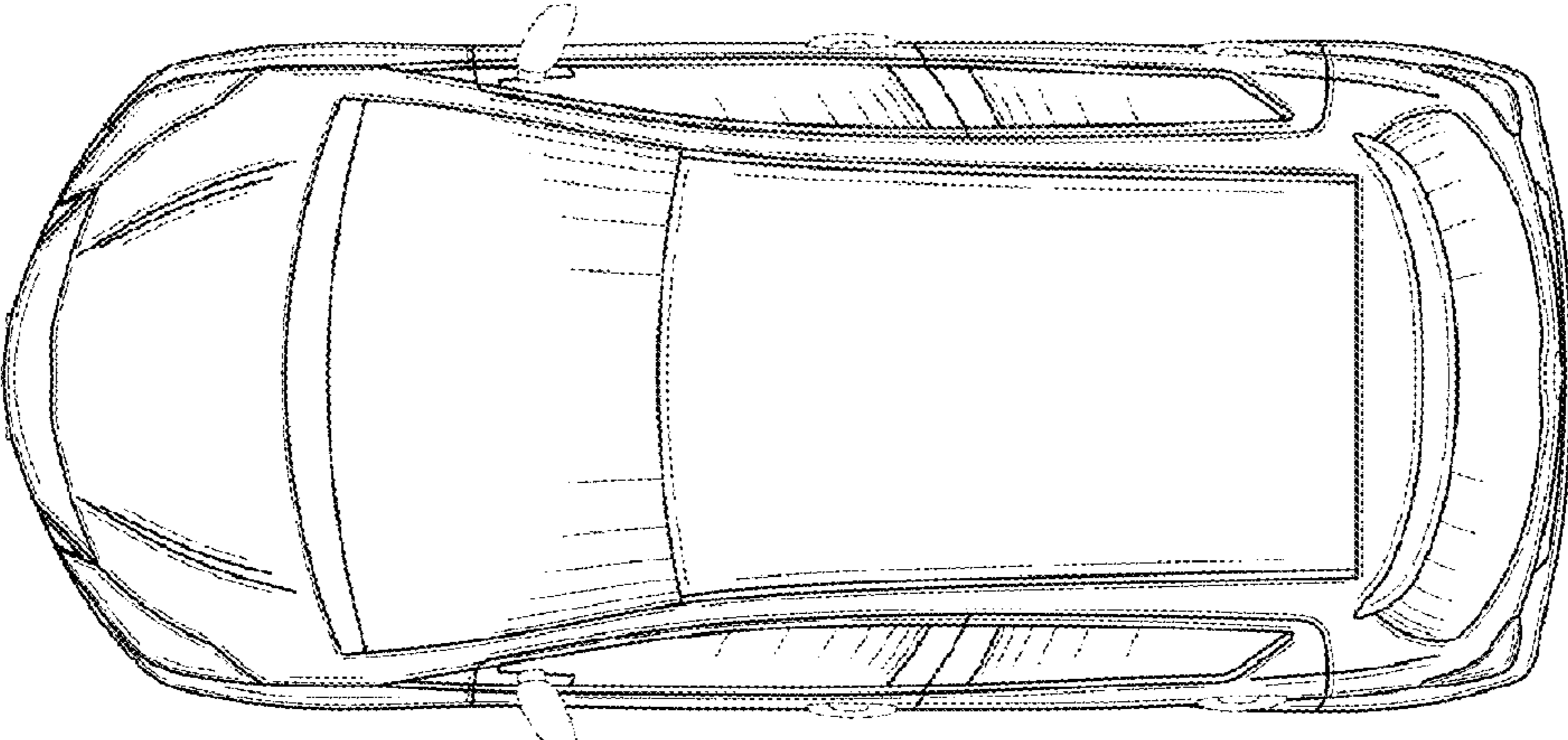

FIG. 4

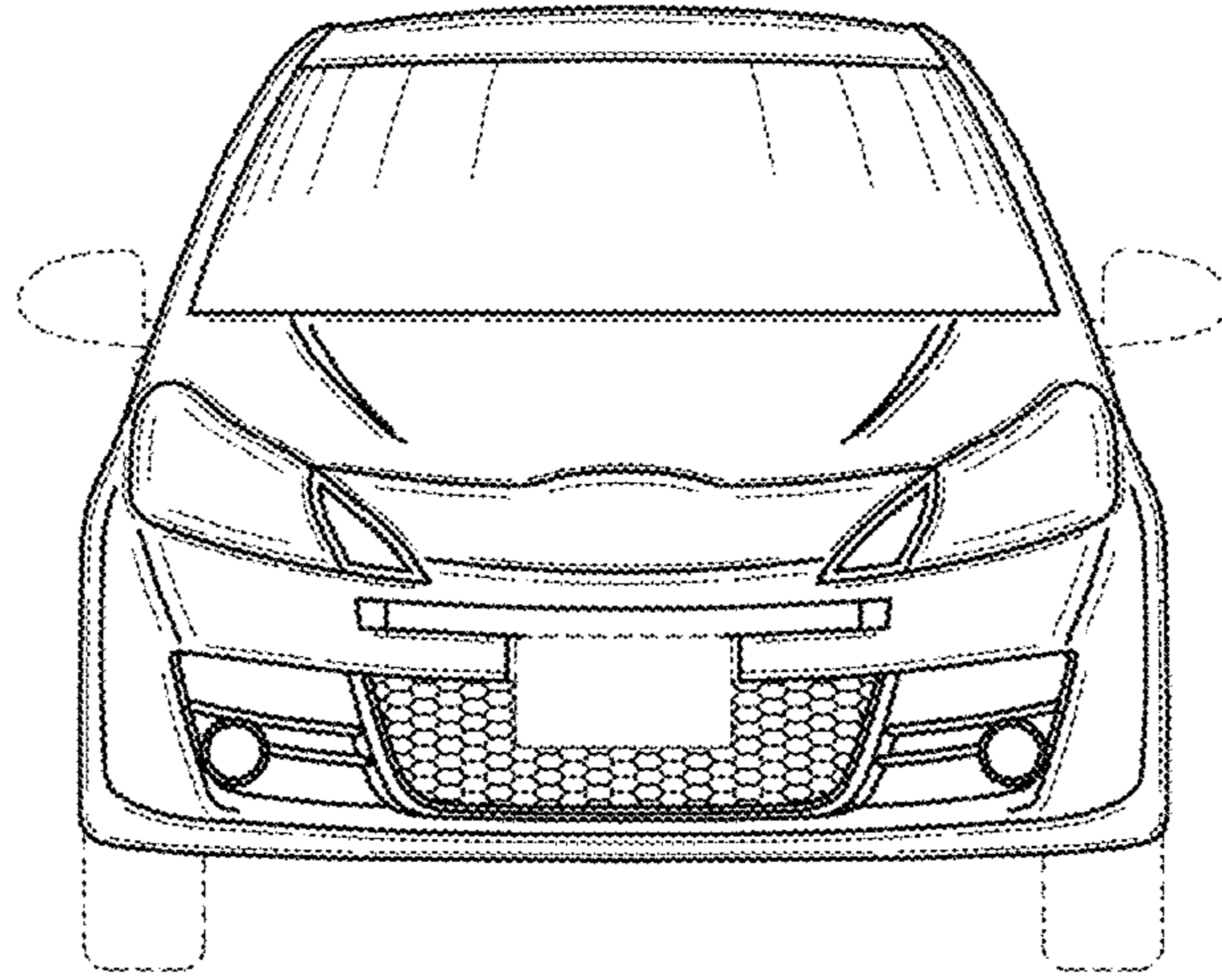

FIG. 5

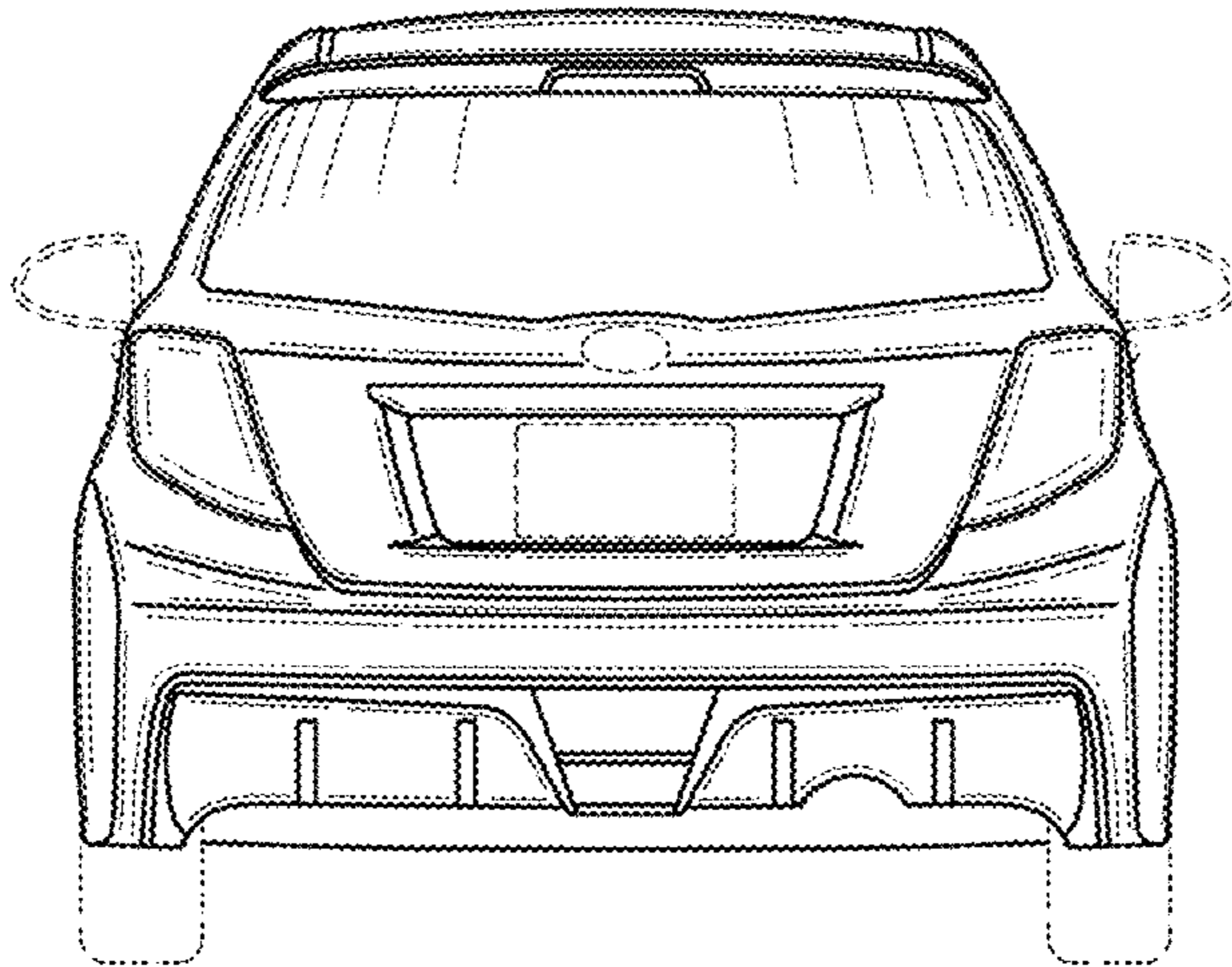

FIG. 6