



US00D689396S

(12) **United States Design Patent**  
**Wang**

(10) **Patent No.:** **US D689,396 S**

(45) **Date of Patent:** **\*\* Sep. 10, 2013**

(54) **ALL TERRAIN VEHICLE**

(75) Inventor: **Heyuan Wang**, Zhejiang Province (CN)

(73) Assignee: **Zhejiang Xinyang Industry Co., Ltd.**,  
Zhejiang Province (CN)

(\*\*) Term: **14 Years**

(21) Appl. No.: **29/391,300**

(22) Filed: **May 6, 2011**

(30) **Foreign Application Priority Data**

Apr. 3, 2011 (CN) ..... 2011 3 0065945

(51) **LOC (9) Cl.** ..... **12-13**

(52) **U.S. Cl.**  
USPC ..... **D12/14**

(58) **Field of Classification Search**  
USPC ..... D12/87, 86, 1, 433, 15, 16, 107,  
D12/82, 88, 89, 90, 91, 92, 93, 14; D15/30;  
D21/803; 180/233, 908; 280/DIG. 5, 183,  
280/184, 185, 186, 28, 37.7  
See application file for complete search history.

(56) **References Cited**

**U.S. PATENT DOCUMENTS**

D498,435 S \* 11/2004 Saito et al. .... D12/1  
D503,905 S \* 4/2005 Saito et al. .... D12/1  
D605,555 S \* 12/2009 Tanaka et al. .... D12/14

D606,900 S \* 12/2009 Flores ..... D12/87  
D636,295 S \* 4/2011 Eck et al. .... D12/1  
D640,597 S \* 6/2011 Zhang ..... D12/16  
D646,202 S \* 10/2011 Zhang ..... D12/16  
D646,604 S \* 10/2011 Zhang ..... D12/16  
2009/0184541 A1\* 7/2009 Yamamura et al. .... 296/190.08

\* cited by examiner

*Primary Examiner* — T. Chase Nelson

*Assistant Examiner* — Ania Aman

(57) **CLAIM**

The ornamental design for an all terrain vehicle, as shown and described.

**DESCRIPTION**

FIG. 1 is a front elevational view of an all terrain vehicle according to the present invention;  
FIG. 2 is a rear elevational view thereof of an all terrain vehicle according to the present invention;  
FIG. 3 is a right side view elevation view of an all terrain vehicle according to the present invention;  
FIG. 4 is a left side view elevation view of an all terrain vehicle according to the present invention;  
FIG. 5 is a top plan view of an all terrain vehicle according to the present invention; and,  
FIG. 6 is a front perspective view of an all terrain vehicle according to the present invention.  
The broken lines are for environmental purposes only and form no part of the claimed design.

**1 Claim, 6 Drawing Sheets**

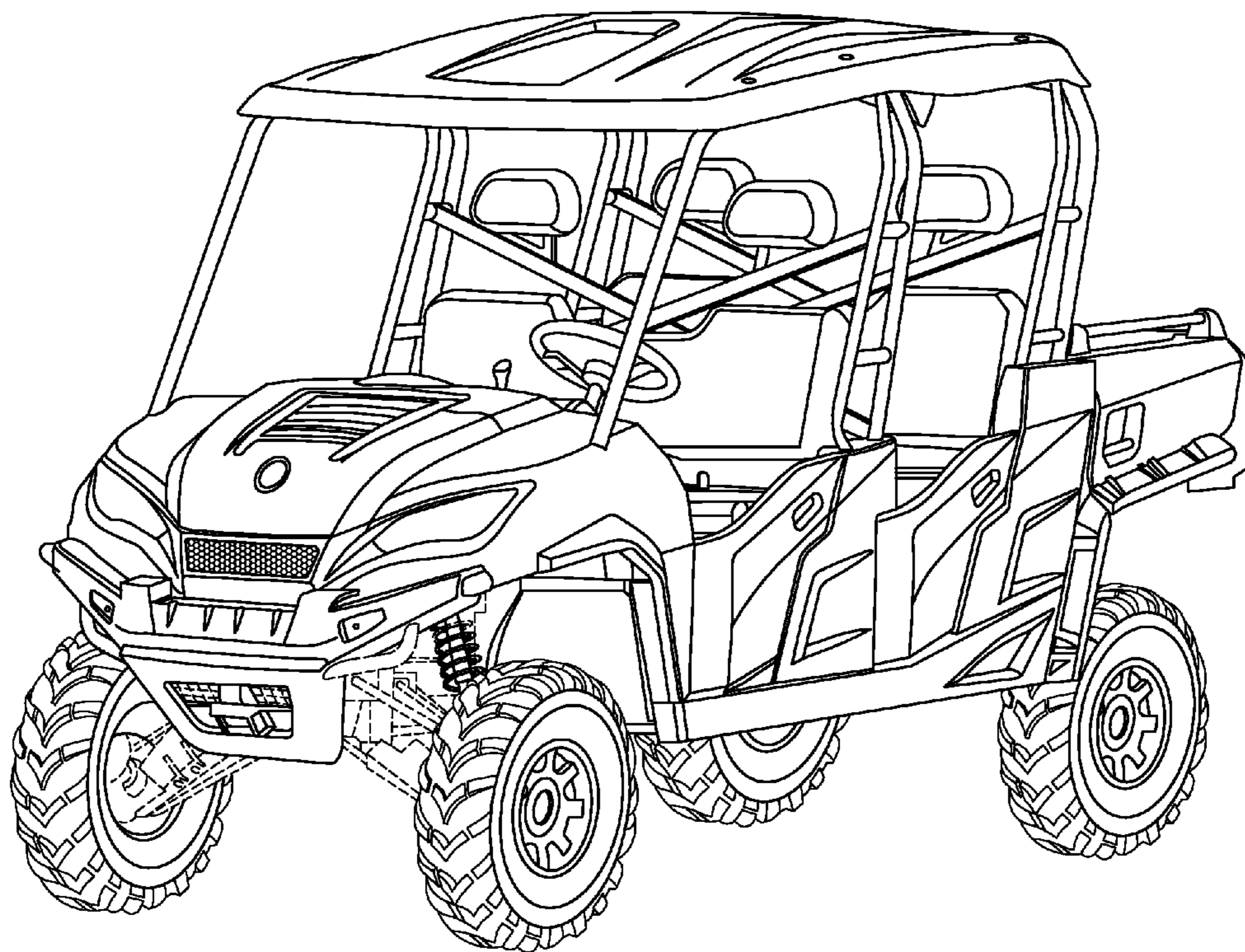

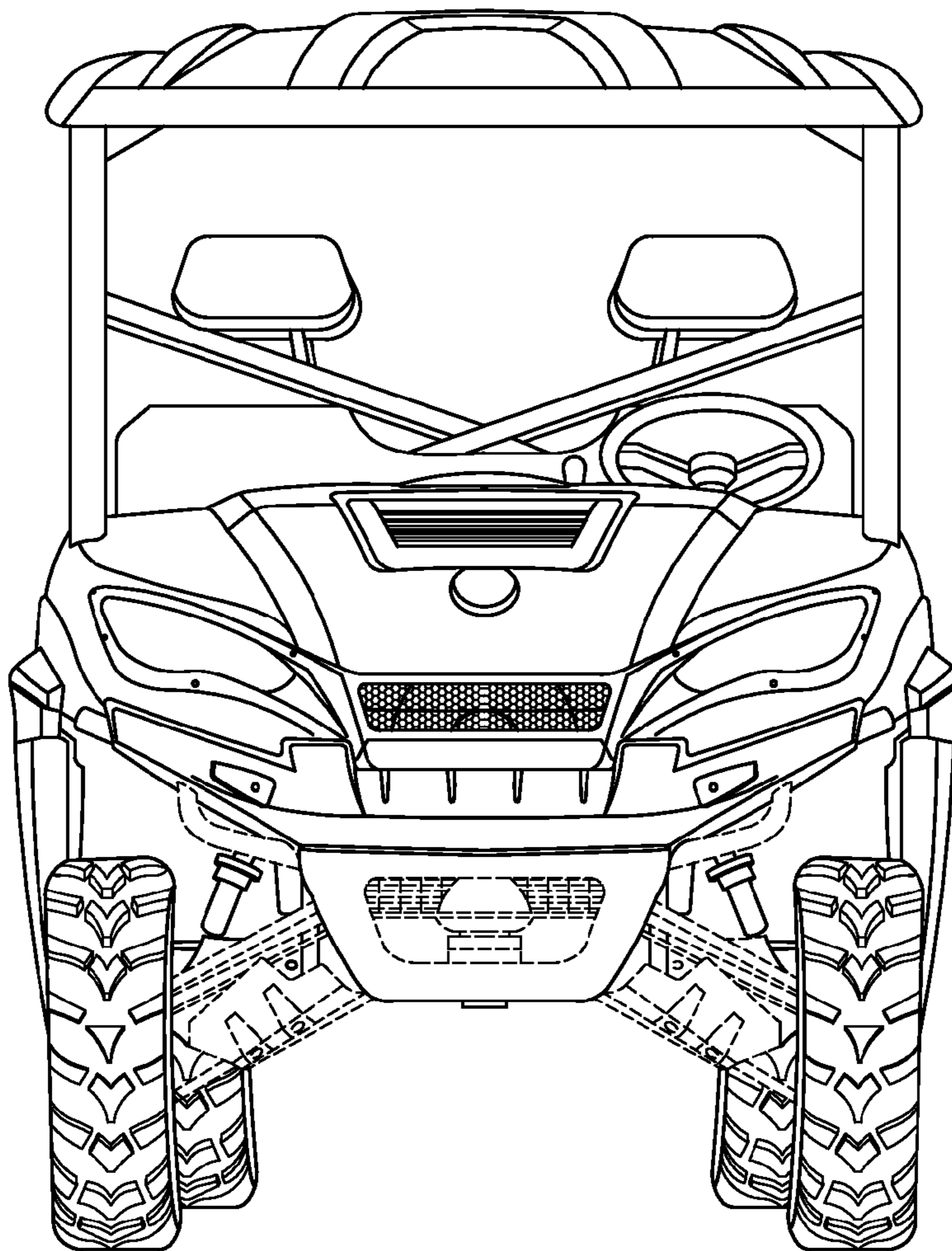

FIG. 1

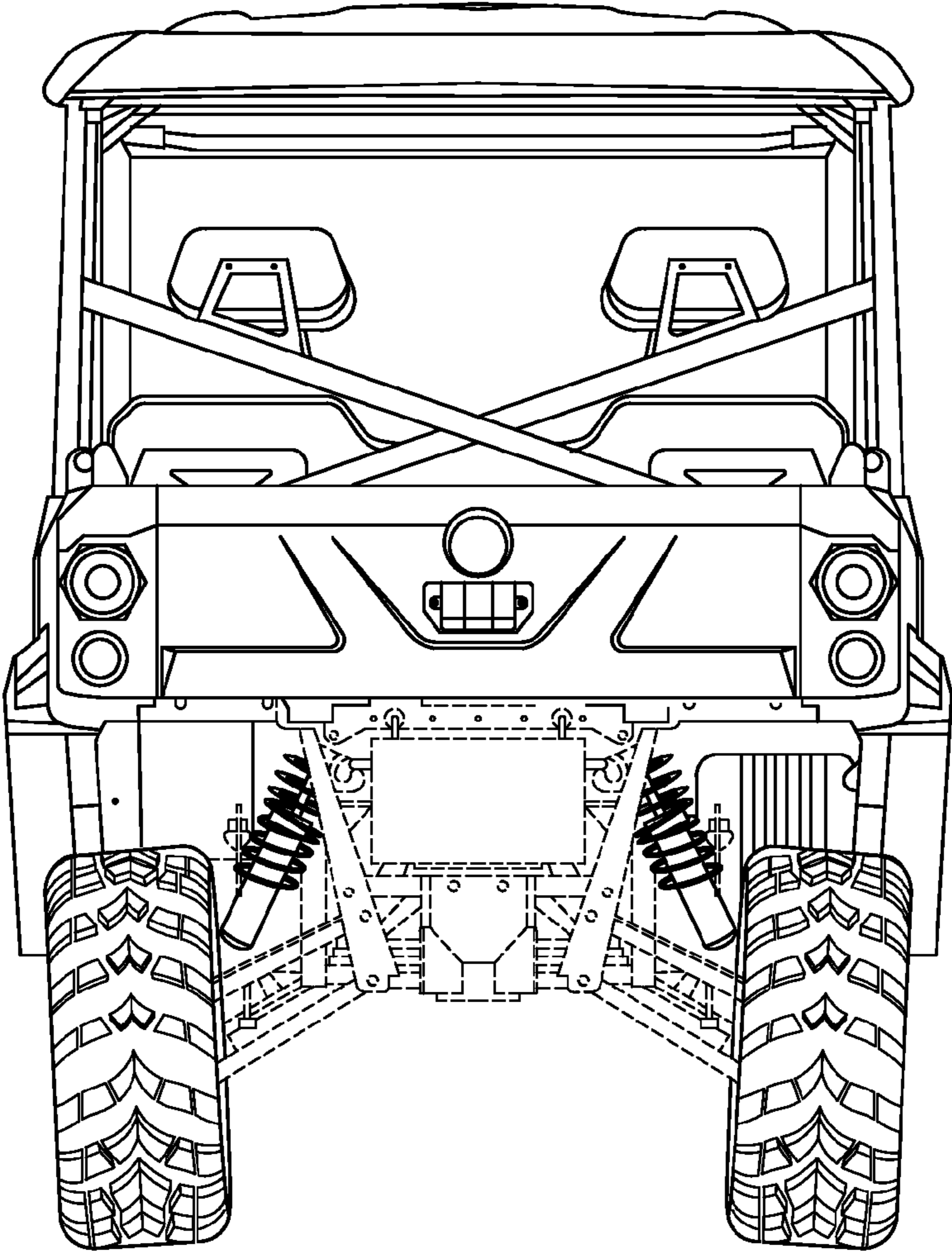

FIG. 2

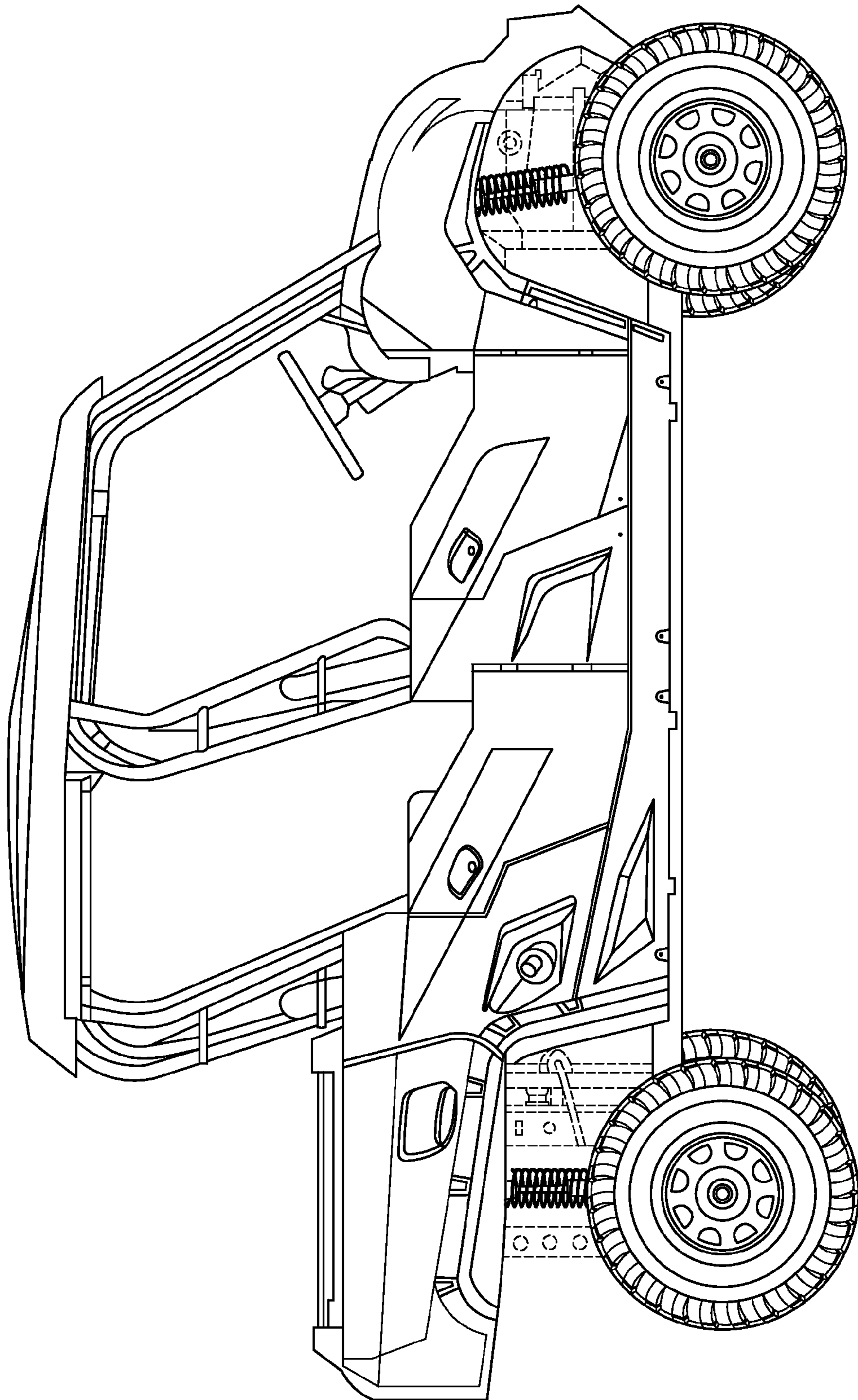

FIG. 3

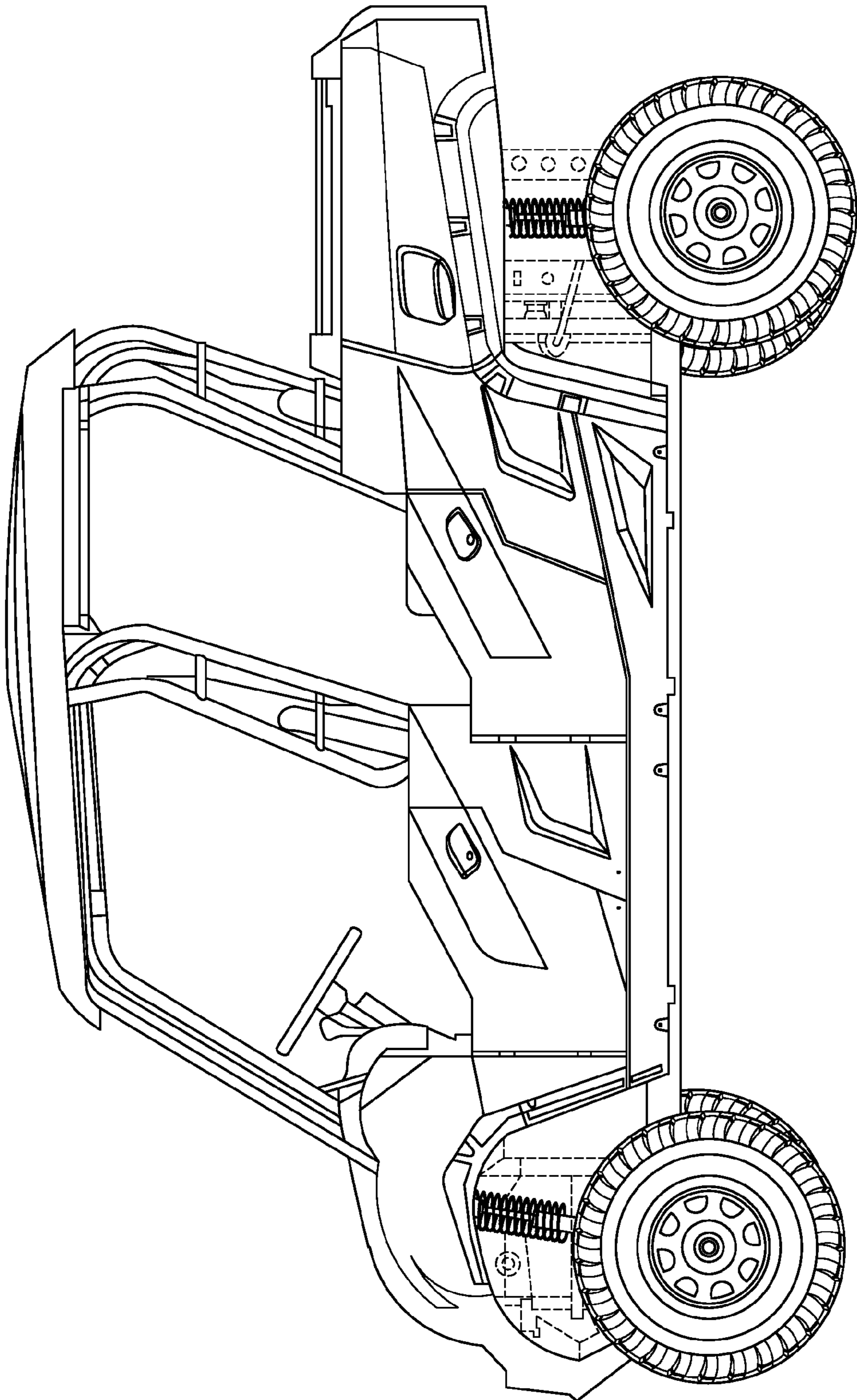

FIG. 4

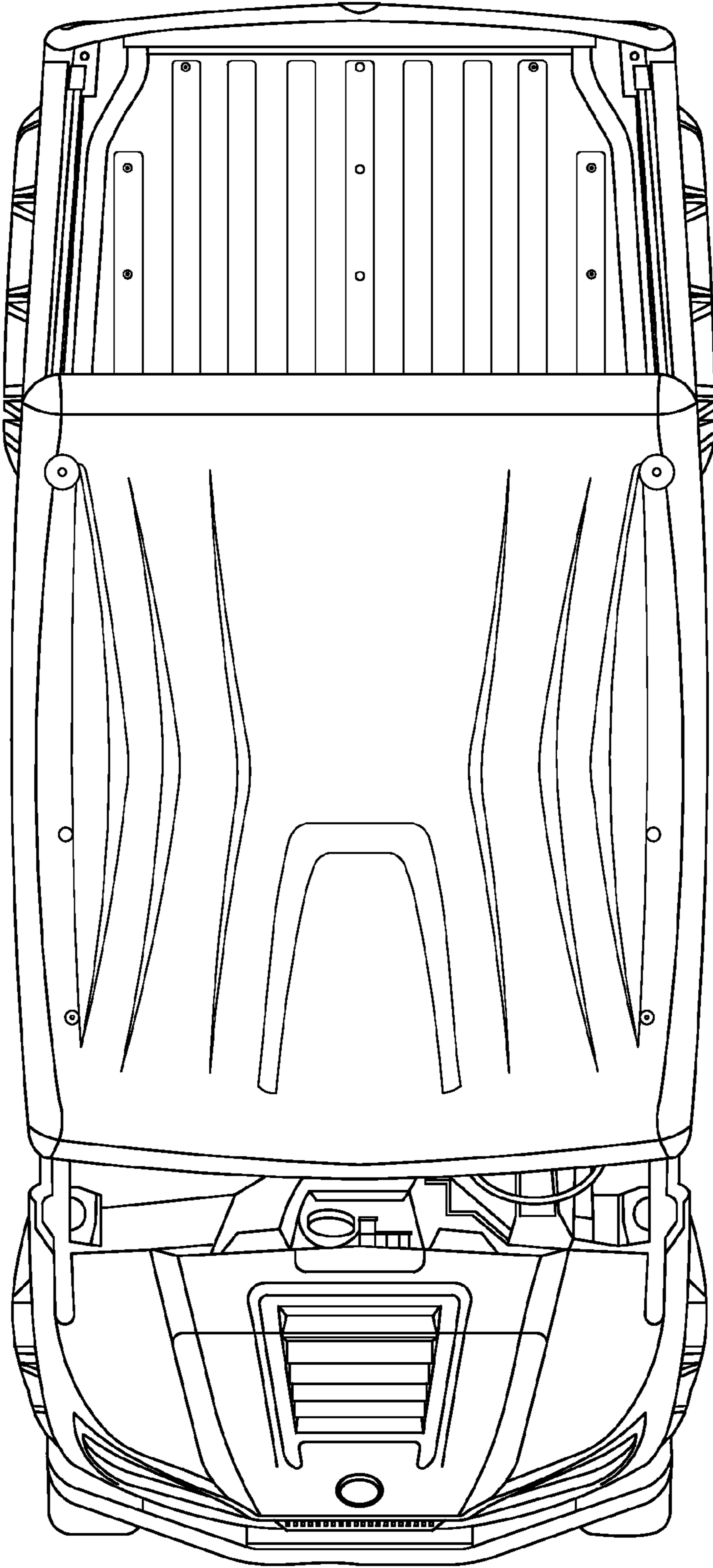

FIG. 5

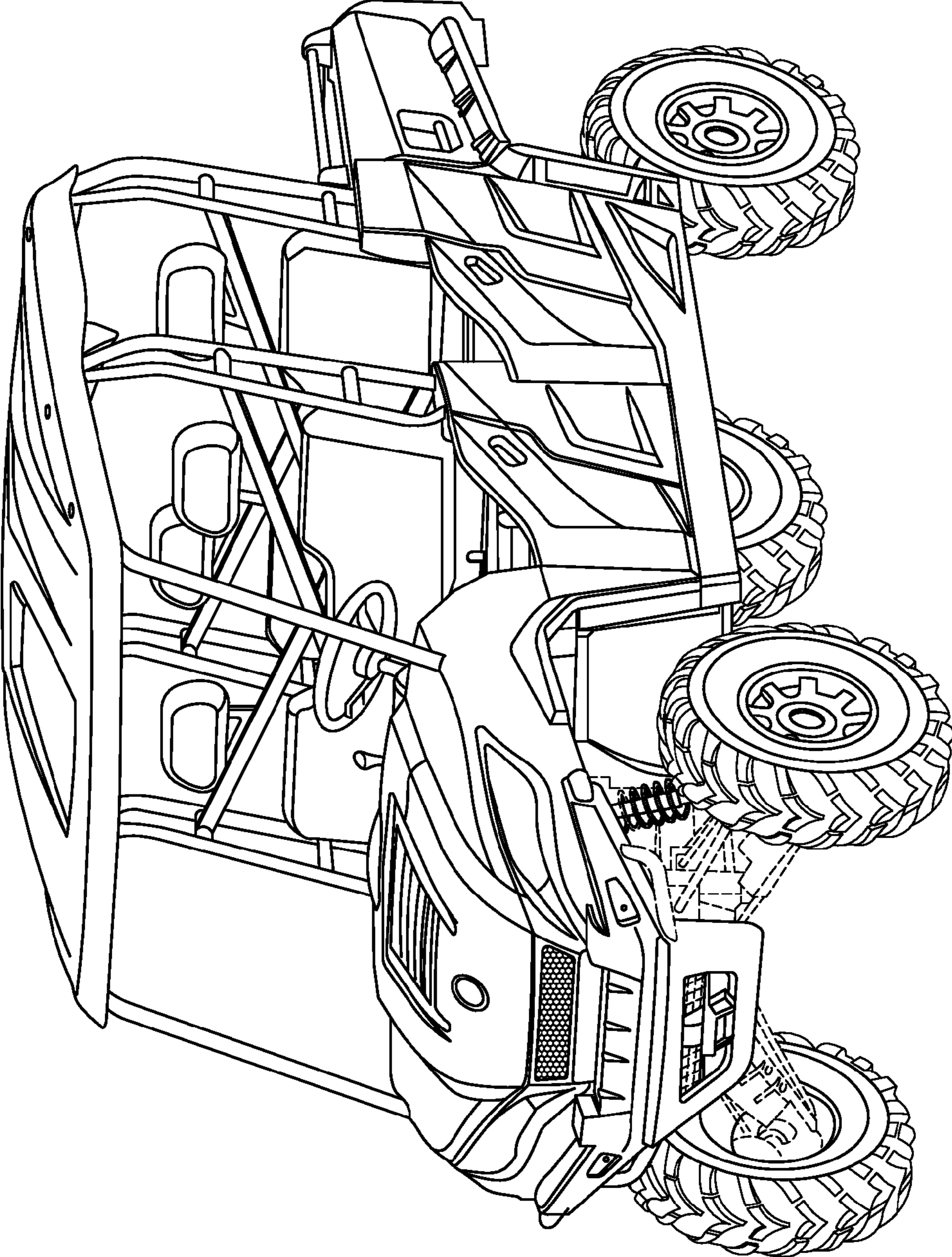

FIG. 6