



US00D689384S

(12) **United States Design Patent**
Morikawa

(10) **Patent No.:** **US D689,384 S**

(45) **Date of Patent:** **** Sep. 10, 2013**

(54) **CAR NAVIGATION**

(71) Applicant: **JVC Kenwood Corporation**, Kanagawa (JP)

(72) Inventor: **Rika Morikawa**, Kanagawa (JP)

(73) Assignee: **JVC Kenwood Corporation**, Kanagawa (JP)

(**) Term: **14 Years**

(21) Appl. No.: **29/438,919**

(22) Filed: **Dec. 5, 2012**

(30) **Foreign Application Priority Data**

Jun. 5, 2012 (JP) 2012-013276

(51) **LOC (9) Cl.** **10-04**

(52) **U.S. Cl.**
USPC **D10/65; D10/70**

(58) **Field of Classification Search**
USPC D10/65, 70, 75, 78; D14/138 R, D14/138 AA, 138 AB, 138 AC, 138 AD, D14/341-347, 507-510, 136, 167, 168, 496, D14/498, 499, 500, 125-134, 239, 371, 374-377, D14/440, 450, 448, 336, 342; 343/702; 345/87, 104, 133, 156, 168, 173, 901-905, 345/165; 348/180, 184, 315, 739, 836, 838, 348/325; 364/444, 499; 701/408-418, 431, 701/432, 537; 312/7.2; 341/12; 720/605, 720/669, 600, 655; 369/99, 197; 455/344, 455/347, 575.1; 250/221, 338.3, 340, 239, 250/342, 341, DIG. 1, 353; 307/116, 117; 340/521, 527, 541, 567, 540, 568.2, 539.23, 340/635, 687; 315/159; 324/72.5, 556, 133, 324/149, 503, 543, 555, 66, 72, 754, 115, 324/141, 522; 73/615, 624, 627, 644, 514.33, 73/514.34, 510, 513, 527, 530; 356/3.01-5.15;

235/105; 377/5, 24.2, 26; 702/155, 160, 702/176, 78, 79, 82, 91-95, 104, 116, 141, 702/150, 151, 154, 127, 131, 182, 183, 189; 600/437, 443, 453, 459, 465, 479, 500, 502, 600/595, 485, 481, 483

See application file for complete search history.

(56) **References Cited**

U.S. PATENT DOCUMENTS

D608,230 S *	1/2010	Sugita	D10/65
D627,244 S *	11/2010	Nakane et al.	D10/65
D653,132 S *	1/2012	Shimizu	D10/65
D672,330 S *	12/2012	Komagamine	D10/65
D673,471 S *	1/2013	Miyawaki	D10/65
D673,472 S *	1/2013	Sugita	D10/65
D676,342 S *	2/2013	Koiwa	D10/65

* cited by examiner

Primary Examiner — Antoine D Davis

(74) *Attorney, Agent, or Firm* — Osha Liang LLP

(57) **CLAIM**

The ornamental design for car navigation, as shown and described.

DESCRIPTION

FIG. 1 is a perspective view of front, right and top of car navigation showing my new design;
FIG. 2 is a front view thereof;
FIG. 3 is a rear view thereof;
FIG. 4 is a left side view thereof;
FIG. 5 is a right side view thereof;
FIG. 6 is a top view thereof; and,
FIG. 7 is a bottom view thereof.
The broken lines showing of car navigation is included for the purpose of illustrating portions of car navigation and forms no part of the claimed design.

1 Claim, 5 Drawing Sheets

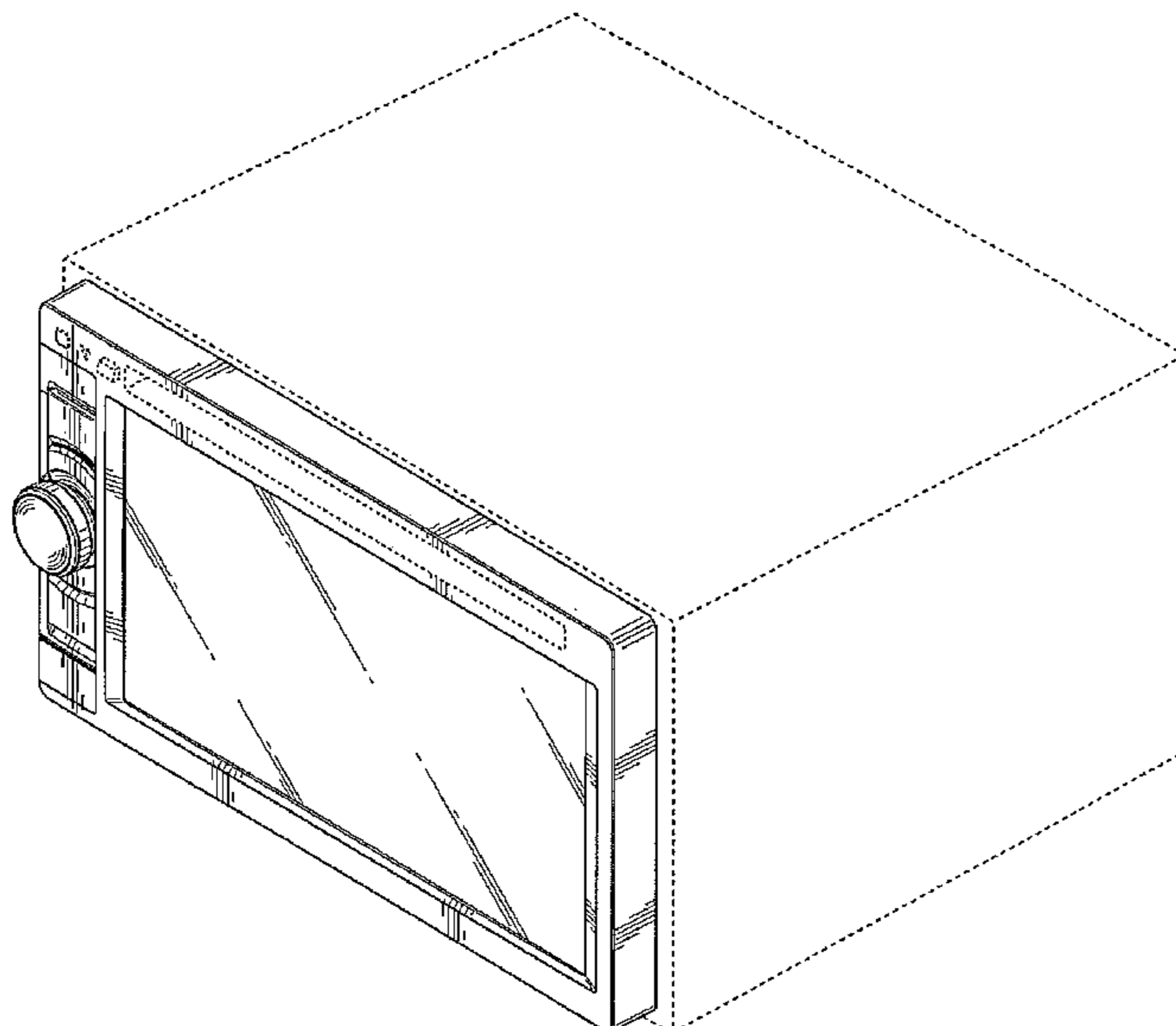

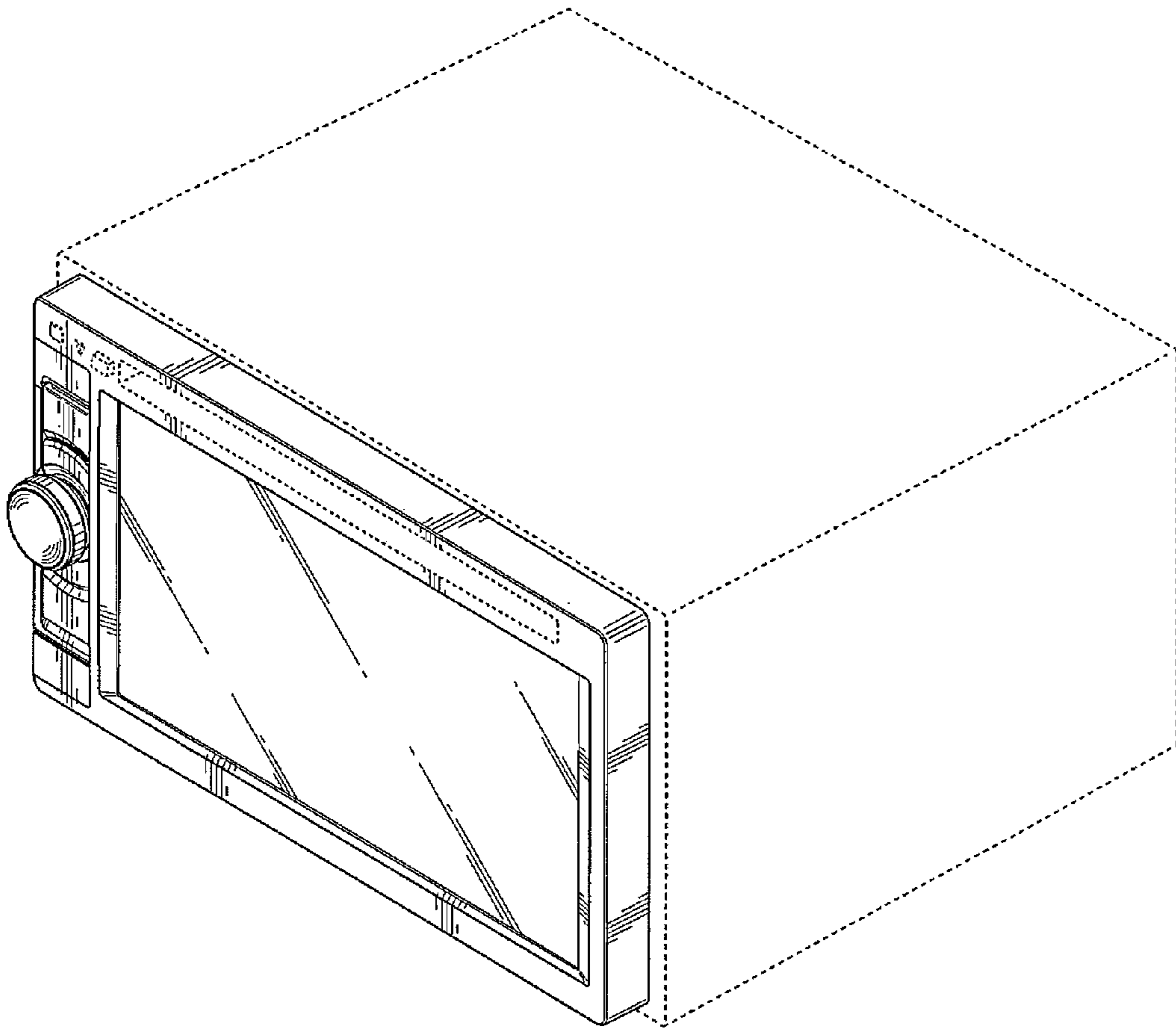

FIG. 1

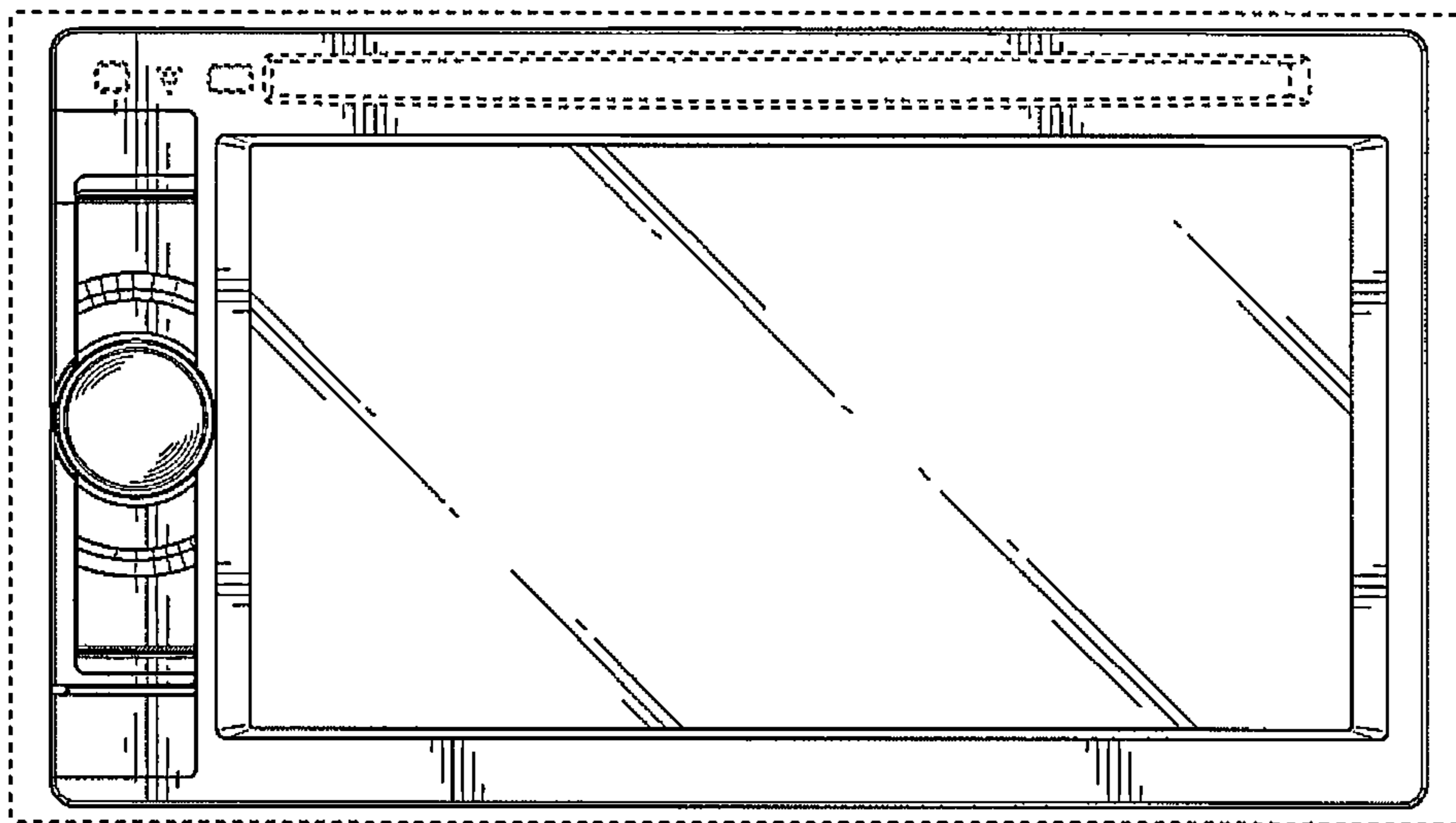

FIG. 2



FIG. 3



FIG. 4



FIG. 5

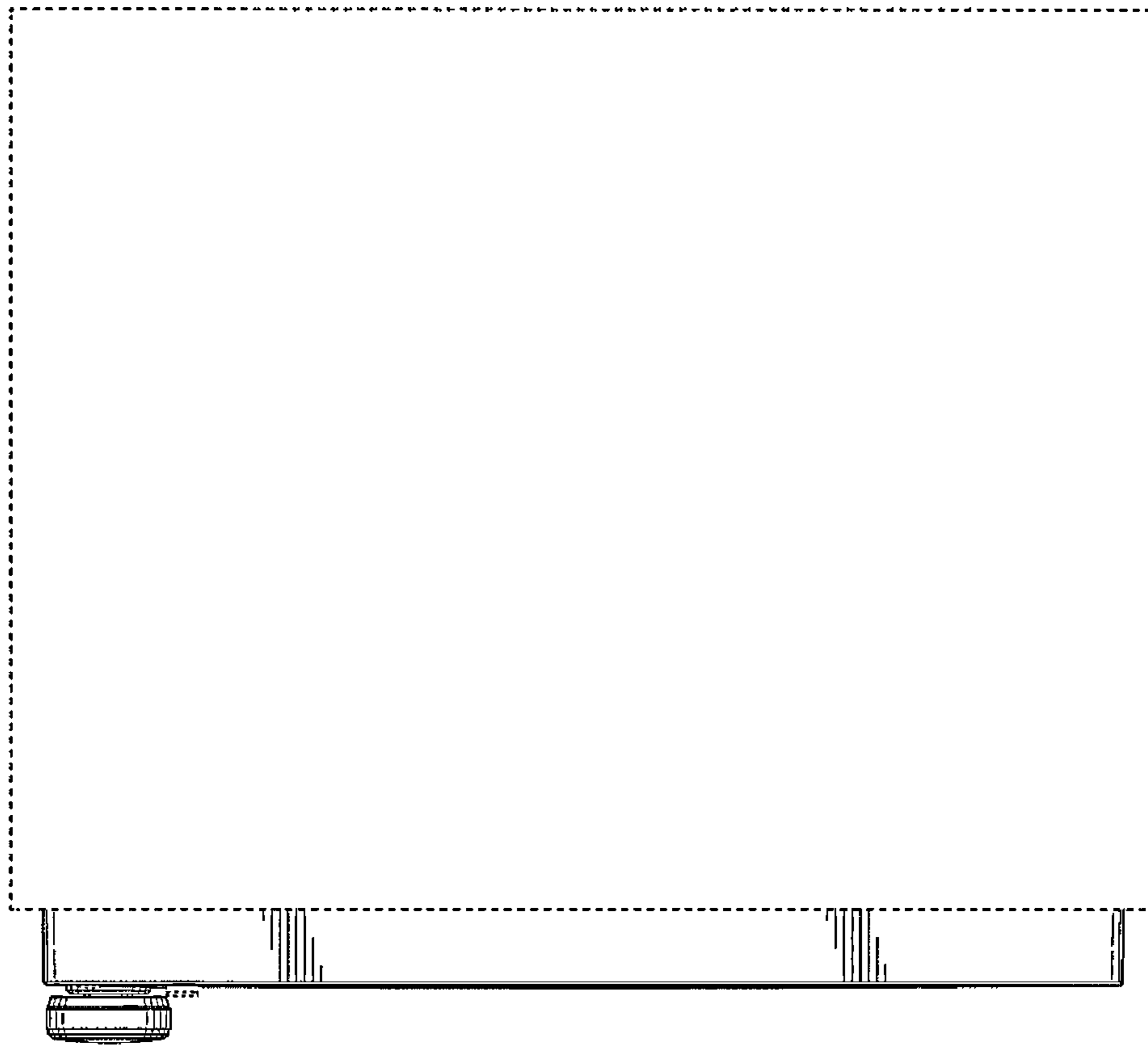

FIG. 6

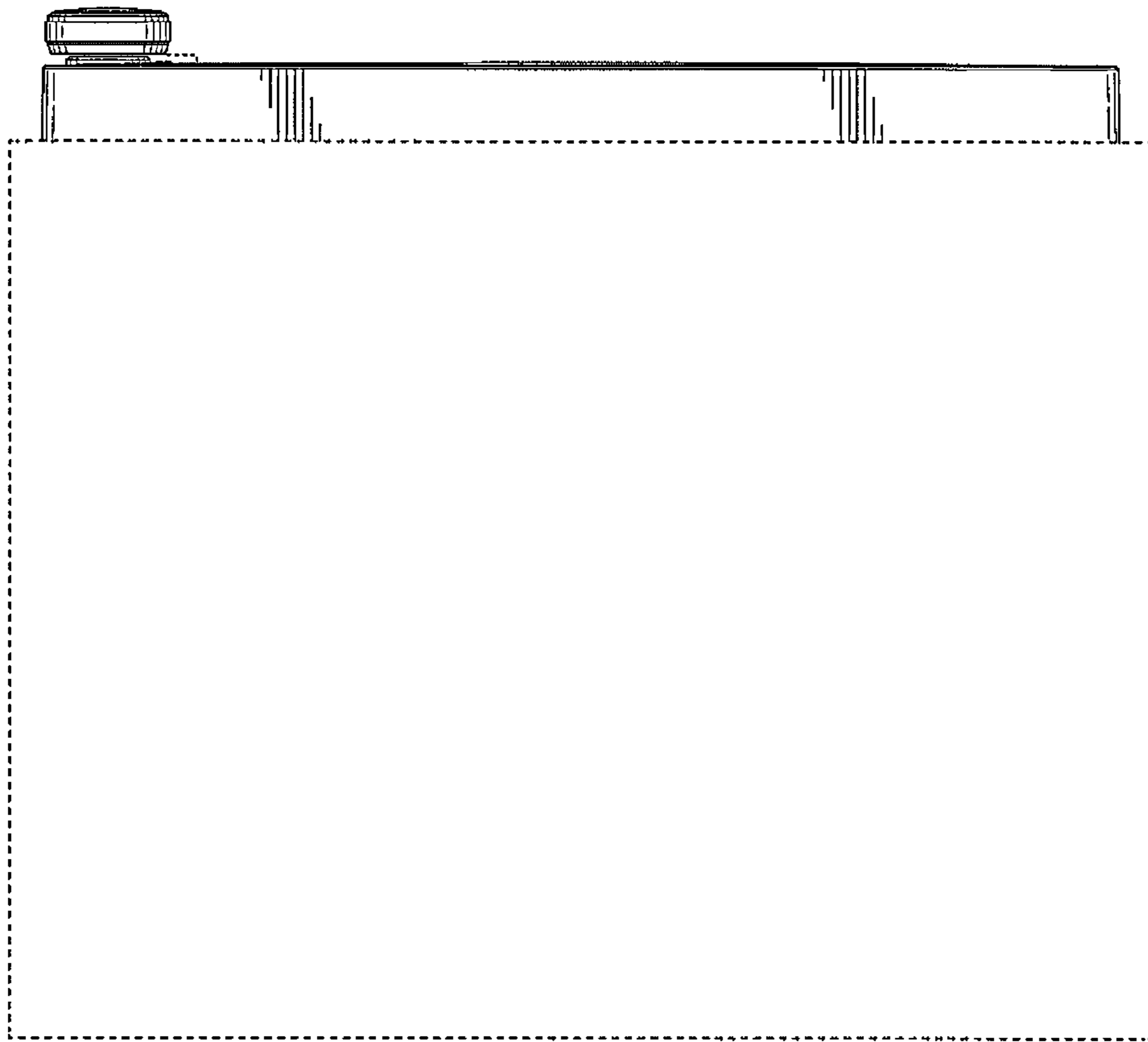

FIG. 7