



US00D689245S

(12) **United States Design Patent**  
**Rowe et al.**

(10) **Patent No.:** **US D689,245 S**  
(45) **Date of Patent:** **\*\* Sep. 3, 2013**

(54) **PET WATER FOUNTAIN**

(71) Applicant: **Radio Systems Corp.**, Knoxville, TN (US)

(72) Inventors: **Sean Rowe**, Reno, NV (US); **Junzhou Huang**, Guangdong Sheng (CN)

(73) Assignee: **Radio Systems Corp.**, Knoxville, TN (US)

(\*\*) Term: **14 Years**

(21) Appl. No.: **29/449,001**

(22) Filed: **Mar. 14, 2013**

(51) **LOC (9) Cl.** ..... **30-03**

(52) **U.S. Cl.**  
USPC ..... **D30/132**

(58) **Field of Classification Search**  
USPC ..... D30/123, 129, 132, 121; 119/69.5, 119/673, 57.8, 68, 74, 61.57, 78-81, 61.4, 119/57.9, 51.5, 61.5, 72; 47/66.6, 39, 67, 47/83; 239/27, 280, 200, 281, 280.5, 273, 239/16, 17, 20, 22; 4/644, 627, 638; D7/558; D11/144, 145, 153; D99/5, 24; 27/1; D23/201, 292; 248/127, 132, 137, 138, 248/158, 910; 215/10; D6/353, 352, 484, D6/360, 480, 488; 219/521; 329/442, 459  
See application file for complete search history.

(56) **References Cited**

U.S. PATENT DOCUMENTS

117,807 A \* 8/1871 Orndorff ..... 119/77  
258,619 A \* 5/1882 Welty ..... 119/80

(Continued)

OTHER PUBLICATIONS

ETSY website from ceramic pet bowl artist printed Mar. 26, 2013 (2 pages).

(Continued)

*Primary Examiner* — Susan Moon Lee

(74) *Attorney, Agent, or Firm* — Peter L. Brewer; Baker, Donelson, Bearman, Caldwell & Berkowitz, PC

(57) **CLAIM**

We claim the ornamental design for a pet water fountain, as shown and described.

**DESCRIPTION**

FIG. 1 is an exploded perspective view showing our new design for a pet water fountain.

FIG. 2 is a first perspective view showing just the bowl for the pet water fountain of FIG. 1. The view is seen from a first direction.

FIG. 3 is a second perspective view of the bowl for the pet water fountain of FIGS. 1 and 2. The view is seen from a second opposite direction wherein a bottom of the bowl is visible.

FIG. 4 is a front view of the bowl of FIGS. 2 and 3. The back view is identical to the front view.

FIG. 5 is a right side view of the bowl of FIGS. 2 and 3. The left side elevation view is a mirror image of the right side.

FIG. 6 is a top or plan view of the bowl of FIGS. 2 and 3.

FIG. 7 is a cross-sectional view of the bowl of FIG. 6, taken across line A-A.

FIG. 8 is a bottom view of the bowl of FIGS. 2 and 3.

FIG. 9 is a perspective view of just the tower for the pet water fountain of FIG. 1.

FIG. 10 is a right side view of the tower for the pet water fountain of FIG. 9. The left elevation view is identical to the right side view.

FIG. 11 is a front side view of the tower of FIG. 9. The back side elevation view is identical to the front side.

FIG. 12 is a cross-sectional view of the tower of FIG. 11, taken across line A-A.

FIG. 13 is a top view of the tower of FIG. 9; and,

FIG. 14 is a bottom view of the tower of FIG. 9.

Broken lines and portions contained within broken lines are not claimed.

**1 Claim, 6 Drawing Sheets**

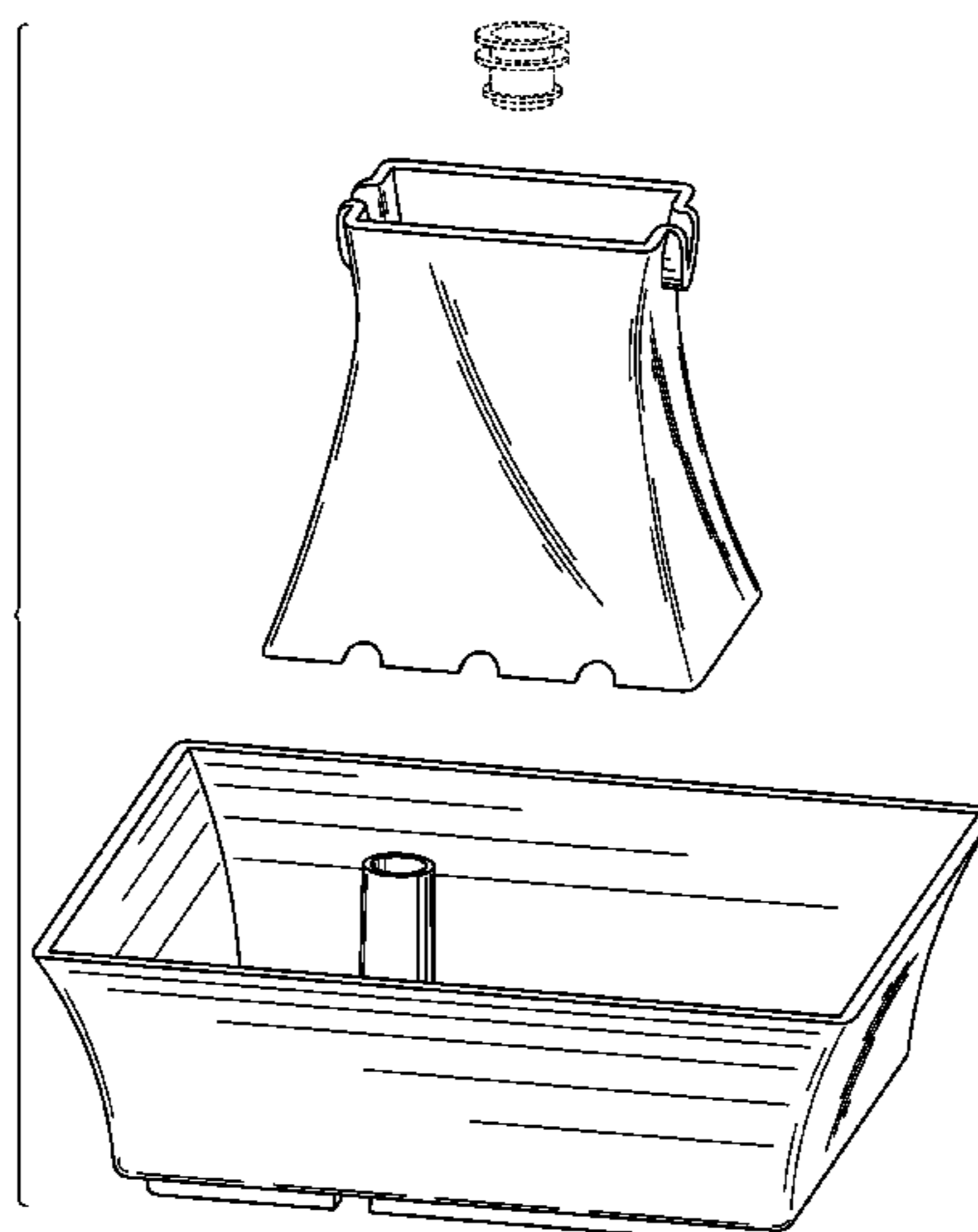



(56)

## References Cited

- U.S. PATENT DOCUMENTS
- 280,291 A \* 6/1883 Bunnell ..... 43/121  
 383,124 A \* 5/1888 Haskins ..... 119/78  
 531,527 A \* 12/1894 Haag ..... 119/61.1  
 D31,784 S \* 11/1899 Howle ..... D7/360  
 816,557 A \* 4/1906 Church ..... 119/77  
 898,716 A \* 9/1908 Bernard ..... 119/80  
 986,945 A \* 3/1911 Ruggles ..... 119/77  
 987,551 A \* 3/1911 Chambers ..... 119/77  
 1,005,659 A \* 10/1911 Sexton ..... 119/77  
 1,010,543 A \* 12/1911 Walter et al. .... 119/77  
 1,033,018 A \* 7/1912 Hutchins ..... 119/78  
 1,091,392 A \* 3/1914 Schlichtinger ..... 119/77  
 1,093,335 A \* 4/1914 Kenly ..... 119/77  
 1,121,528 A \* 12/1914 Mueller ..... 119/77  
 1,180,285 A \* 4/1916 Derr ..... 119/77  
 1,278,285 A 9/1918 Allen  
 1,339,625 A \* 5/1920 Holloway ..... 99/346  
 D57,119 S \* 2/1921 Eaton ..... D30/129  
 D58,196 S \* 6/1921 McCollough ..... D30/132  
 1,481,365 A 1/1924 Ehgel  
 1,567,760 A \* 12/1925 Sittig ..... 119/77  
 D75,218 S \* 5/1928 Cowan ..... D11/155  
 1,725,628 A \* 8/1929 Gerhardt ..... 119/78  
 1,846,455 A \* 2/1932 Quinn ..... 119/78  
 1,890,907 A \* 12/1932 Hoover ..... 99/419  
 1,961,092 A \* 5/1934 Smith ..... 119/80  
 2,034,968 A 3/1936 Bartlett  
 2,103,653 A 12/1937 Weil  
 2,150,499 A \* 3/1939 Goltz ..... 119/79  
 D126,997 S \* 5/1941 Bentzen et al. .... D30/129  
 2,338,072 A \* 12/1943 Quinn ..... 119/78  
 2,366,766 A 1/1945 Brodsky  
 2,510,252 A 1/1945 Pine  
 2,510,446 A 6/1950 Weil  
 D162,476 S \* 3/1951 Saunders et al. .... D30/131  
 2,568,534 A \* 9/1951 Baker ..... 108/33  
 2,572,379 A 10/1951 Pearse  
 2,678,630 A 5/1954 Frederiksen  
 2,726,636 A 12/1955 Frederiksen  
 2,775,227 A 12/1956 Millies  
 2,796,042 A \* 6/1957 Cope ..... 119/69.5  
 2,878,781 A 3/1959 Wingfield  
 D185,872 S \* 8/1959 Forsman ..... D7/555  
 2,990,809 A \* 7/1961 Phillips ..... 119/78  
 3,063,417 A \* 11/1962 Blosser ..... 119/79  
 3,179,085 A 4/1965 McKillip  
 3,228,377 A 1/1966 Grassano  
 D205,595 S \* 8/1966 Titus ..... D11/152  
 3,272,181 A 9/1966 Ramsey  
 3,459,159 A 8/1969 Reed  
 3,505,978 A 4/1970 Nilsen  
 3,537,430 A 11/1970 Peppler  
 D220,230 S \* 3/1971 Friedman ..... D28/93  
 3,589,554 A \* 6/1971 Smith ..... 220/23.83  
 3,759,228 A \* 9/1973 Keen ..... 119/79  
 3,777,714 A 12/1973 Danielsson  
 3,831,558 A 8/1974 Forbes  
 D232,743 S \* 9/1974 Mangrum ..... D30/132  
 3,841,268 A \* 10/1974 Bunger ..... 119/73  
 3,868,926 A 3/1975 Olde  
 D236,511 S \* 8/1975 Bunger ..... D30/131  
 3,901,191 A 8/1975 Smith  
 3,903,845 A 9/1975 Little  
 3,948,221 A \* 4/1976 Wiuniski ..... 119/78  
 D241,874 S \* 10/1976 Berglund ..... D11/156  
 D242,267 S \* 11/1976 Feeney ..... D11/155  
 4,018,004 A \* 4/1977 Soffer ..... 47/39  
 4,022,159 A 5/1977 Salvia  
 4,026,067 A \* 5/1977 Wengel ..... 47/39  
 D245,408 S \* 8/1977 Baumann et al. .... D11/155  
 D245,684 S \* 9/1977 Julinot ..... D11/155  
 4,098,229 A 7/1978 Haynes et al.  
 4,128,080 A \* 12/1978 Haney ..... 119/51.5  
 4,134,365 A \* 1/1979 Futers et al. .... 119/51.5  
 4,138,967 A \* 2/1979 Tamborrino ..... 119/78  
 D254,454 S \* 3/1980 Clugston ..... D30/130  
 4,248,177 A 2/1981 Peterson et al.  
 4,274,365 A \* 6/1981 Peters ..... 119/78  
 4,281,624 A \* 8/1981 Raines ..... 119/52.1  
 4,320,721 A \* 3/1982 Silcox ..... 119/73  
 4,347,809 A 9/1982 Goggler  
 D268,728 S \* 4/1983 Poling ..... D7/555  
 4,386,582 A 6/1983 Adsit  
 4,469,049 A 9/1984 Waynick  
 4,573,433 A 3/1986 Thompson  
 4,584,966 A 4/1986 Moore  
 D289,208 S \* 4/1987 Fanciullo ..... D30/129  
 4,705,216 A 11/1987 Kaffa et al.  
 4,717,051 A \* 1/1988 Leclerc ..... 222/545  
 D294,749 S \* 3/1988 Fuller ..... D30/132  
 4,747,538 A 5/1988 Dunn et al.  
 4,807,565 A 2/1989 Hawthorne  
 4,833,999 A \* 5/1989 Rhoades ..... 108/38  
 4,836,142 A 6/1989 Duback  
 D302,755 S \* 8/1989 Zaliti ..... D30/130  
 4,896,627 A \* 1/1990 Riddell ..... 119/51.5  
 4,924,812 A 5/1990 Bernays  
 4,976,220 A 12/1990 Gershman  
 5,016,572 A \* 5/1991 Weber et al. .... 119/52.1  
 5,113,800 A \* 5/1992 Van Epps et al. .... 119/78  
 5,153,950 A \* 10/1992 Sowers ..... 4/580  
 5,167,368 A 12/1992 Nash  
 D338,088 S \* 8/1993 Bailey ..... D30/131  
 D338,287 S \* 8/1993 Tonner ..... D30/122  
 D342,353 S \* 12/1993 Anastasi ..... D30/130  
 5,277,149 A \* 1/1994 East ..... 119/51.5  
 D346,465 S \* 4/1994 Russell et al. .... D30/130  
 D347,143 S \* 5/1994 Awyong ..... D7/354  
 5,329,876 A 7/1994 Tracy  
 D350,842 S 9/1994 VanSkiver  
 D354,377 S \* 1/1995 Wenstrand ..... D30/131  
 D360,497 S \* 7/1995 Lewis et al. .... D30/129  
 D363,046 S \* 10/1995 Rimback ..... D11/155  
 D363,573 S \* 10/1995 Rehn ..... D30/130  
 D367,735 S 3/1996 VanSkiver et al.  
 5,501,178 A 3/1996 Kemp  
 D374,516 S 10/1996 Lillelund et al.  
 5,560,315 A \* 10/1996 Lampe ..... 119/51.5  
 5,619,952 A \* 4/1997 Walker ..... 119/61.53  
 5,637,361 A 6/1997 Scheurich  
 D383,797 S 9/1997 Finnegan  
 5,676,050 A \* 10/1997 Beck ..... 99/428  
 D389,011 S \* 1/1998 DeCoster ..... D7/387  
 5,743,210 A \* 4/1998 Lampe ..... 119/51.5  
 D394,827 S \* 6/1998 Ruthenberg ..... D11/155  
 5,758,599 A \* 6/1998 Glanville ..... 119/77  
 5,775,586 A \* 7/1998 Hamilton-Bruzzi et al. ... 239/20  
 5,794,564 A \* 8/1998 Paro ..... 119/61.53  
 5,799,609 A 9/1998 Burns et al.  
 5,809,934 A \* 9/1998 Gavet ..... 119/52.1  
 D402,425 S \* 12/1998 Lacz et al. .... D30/121  
 5,842,437 A 12/1998 Burns  
 D412,297 S \* 7/1999 Roach ..... D11/152  
 5,960,741 A \* 10/1999 Ballen et al. .... 119/72  
 D418,008 S \* 12/1999 Rachel et al. .... D7/359  
 6,055,934 A 5/2000 Burns et al.  
 D426,682 S \* 6/2000 Kreger et al. .... D30/121  
 6,079,361 A \* 6/2000 Howell et al. .... 119/72  
 D428,217 S 7/2000 Rodack et al.  
 6,149,070 A 11/2000 Hones  
 D435,321 S 12/2000 Avila  
 6,192,792 B1 \* 2/2001 Gremillion ..... 99/426  
 6,257,560 B1 \* 7/2001 Kim ..... 261/36.1  
 D447,839 S \* 9/2001 Rasmussen ..... D30/131  
 6,345,466 B1 \* 2/2002 Venanzi ..... 47/66.1  
 D455,979 S \* 4/2002 Salenger ..... D11/155  
 D457,692 S 5/2002 Skurdalsvold et al.  
 6,439,471 B2 \* 8/2002 Ehrlich et al. .... 239/18  
 6,460,483 B1 10/2002 Northrop et al.  
 6,553,943 B1 \* 4/2003 Murphy ..... 119/673  
 6,622,657 B2 9/2003 Northrop et al.  
 D488,401 S \* 4/2004 Gutierrez ..... D11/155  
 D491,061 S \* 6/2004 Bouroullec et al. .... D11/155  
 6,748,669 B1 6/2004 Burgess



# US D689,245 S

Page 3

6,748,699	B2 *	6/2004	Taylor	47/79	7,591,646	B2 *	9/2009	Adair et al.	431/291
6,860,229	B1 *	3/2005	Craft	119/61.5	D602,653	S *	10/2009	Mendenhall	D30/130
6,863,025	B2 *	3/2005	Ness	119/72	7,607,915	B2 *	10/2009	Adair et al.	431/292
6,883,722	B2 *	4/2005	Pankow	239/17	7,654,822	B2 *	2/2010	Soller et al.	431/289
D507,755	S *	7/2005	Reitze	D9/737	D612,290	S *	3/2010	Donovan	D11/155
D512,801	S *	12/2005	Kratzer et al.	D30/130	7,699,603	B2 *	4/2010	Furner et al.	431/292
6,971,331	B1 *	12/2005	Rohrer	119/77	7,731,492	B2 *	6/2010	Kubicek et al.	431/325
7,007,634	B1 *	3/2006	Pederson	119/78	7,757,636	B2	7/2010	McCallum et al.	
7,051,677	B2 *	5/2006	Van Epps et al.	119/78	7,914,166	B2 *	3/2011	MacAlister	362/101
7,089,881	B2	8/2006	Plante		7,918,186	B2	4/2011	Rowe et al.	
D530,838	S *	10/2006	Adams	D26/9	D637,770	S	5/2011	Lipscomb et al.	
D532,715	S *	11/2006	Schmidt	D11/155	7,958,844	B1	6/2011	Northrop	
D533,952	S *	12/2006	Adams et al.	D26/9	D642,745	S	8/2011	Veness et al.	
D534,283	S *	12/2006	Adams et al.	D26/9	D642,746	S	8/2011	Weber	
7,146,930	B1 *	12/2006	Ness	119/77	7,987,817	B2	8/2011	Johnson	
D534,666	S *	1/2007	Adams et al.	D26/9	D657,612	S *	4/2012	Cloutier et al.	D7/354
D538,041	S *	3/2007	Reitze	D3/314	D658,819	S	5/2012	Lipscomb et al.	
D540,962	S *	4/2007	Adams et al.	D26/9	D659,914	S	5/2012	Lipscomb	
7,287,978	B2 *	10/2007	Kubicek et al.	431/292	8,205,575	B2 *	6/2012	Nicastle	119/72
D556,954	S *	12/2007	May	D30/129	D665,134	S	8/2012	Lipscomb et al.	
7,303,142	B2 *	12/2007	Gluck	239/12	D665,870	S *	8/2012	Fang	D23/201
D558,519	S *	1/2008	Zemel	D7/409	8,245,665	B2	8/2012	Willett	
D560,967	S *	2/2008	Zemel	D7/409	D670,450	S *	11/2012	Graves et al.	D30/129
7,325,482	B1 *	2/2008	Bourgeois et al.	99/340	D671,355	S *	11/2012	Zmrhal	D7/360
D564,286	S *	3/2008	Zemel	D7/354	D677,018	S	2/2013	Miller et al.	
D571,688	S *	6/2008	White	D11/155	8,381,685	B2 *	2/2013	Lipscomb et al.	119/74
D574,976	S *	8/2008	Adams et al.	D26/9	8,387,566	B2 *	3/2013	Graves et al.	119/72
D575,421	S *	8/2008	Cotterman et al.	D26/9	D681,887	S *	5/2013	Fang	D30/132
D575,885	S *	8/2008	Adams et al.	D26/20	D681,888	S *	5/2013	Fang	D30/132
D575,886	S *	8/2008	Adams et al.	D26/20	D682,481	S *	5/2013	Krueger	D30/124
D576,319	S *	9/2008	Binetti et al.	D26/23	2011/0067638	A1 *	3/2011	Lipscomb et al.	119/74
D576,750	S *	9/2008	Adams et al.	D26/9					
D577,136	S *	9/2008	Kubicek et al.	D26/20					
D577,447	S *	9/2008	Kubicek et al.	D26/20					
D579,588	S *	10/2008	Adams et al.	D26/9					
7,467,945	B2 *	12/2008	Kubicek et al.	431/291					
D584,430	S *	1/2009	Furner et al.	D26/9					
7,538,272	B1 *	5/2009	Shotey et al.	174/66					

## OTHER PUBLICATIONS

U.S. Appl. No. 29/448,927, filed Mar. 14, 2013 entitled Pet Water Fountain.

\* cited by examiner

FIG. 1

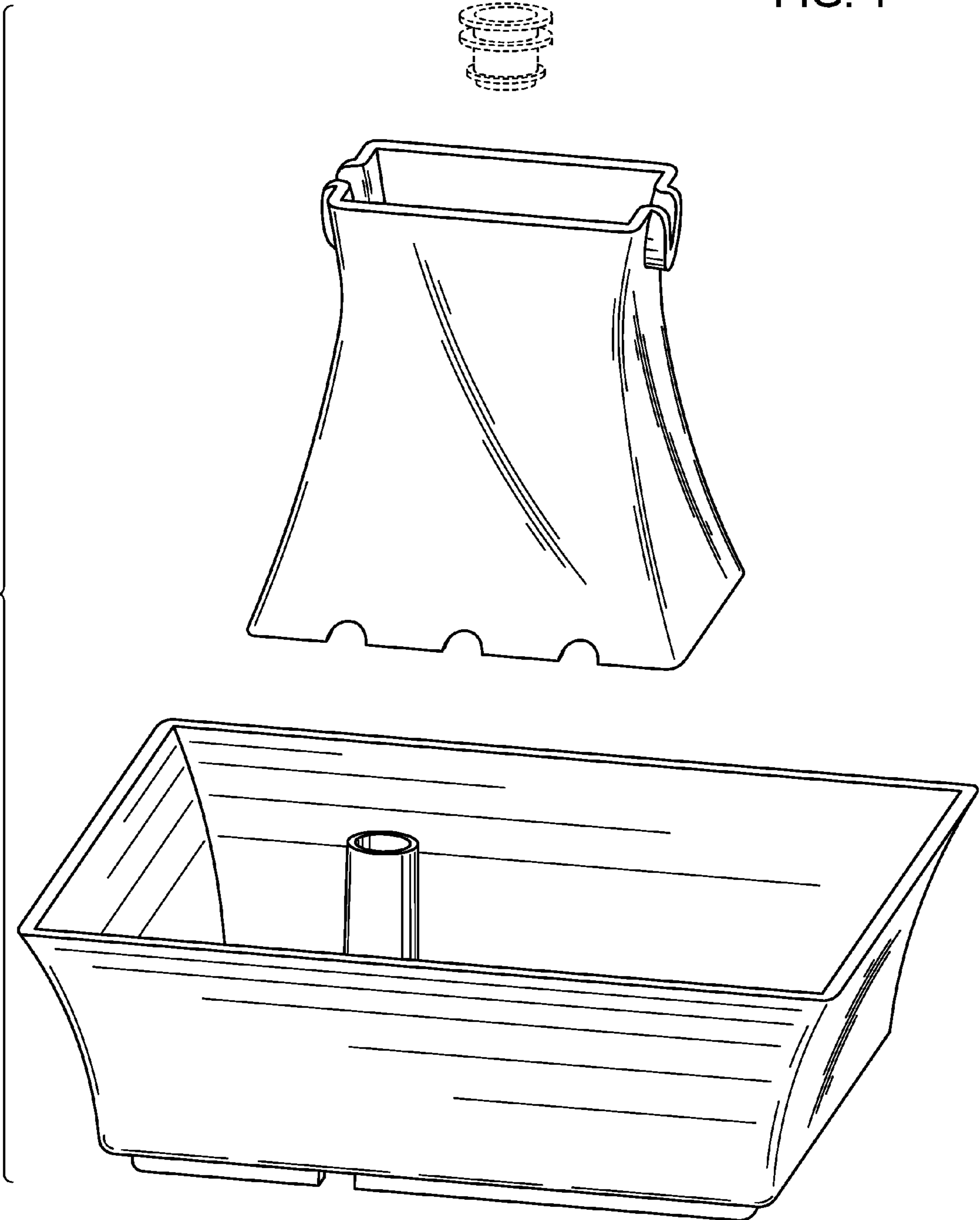

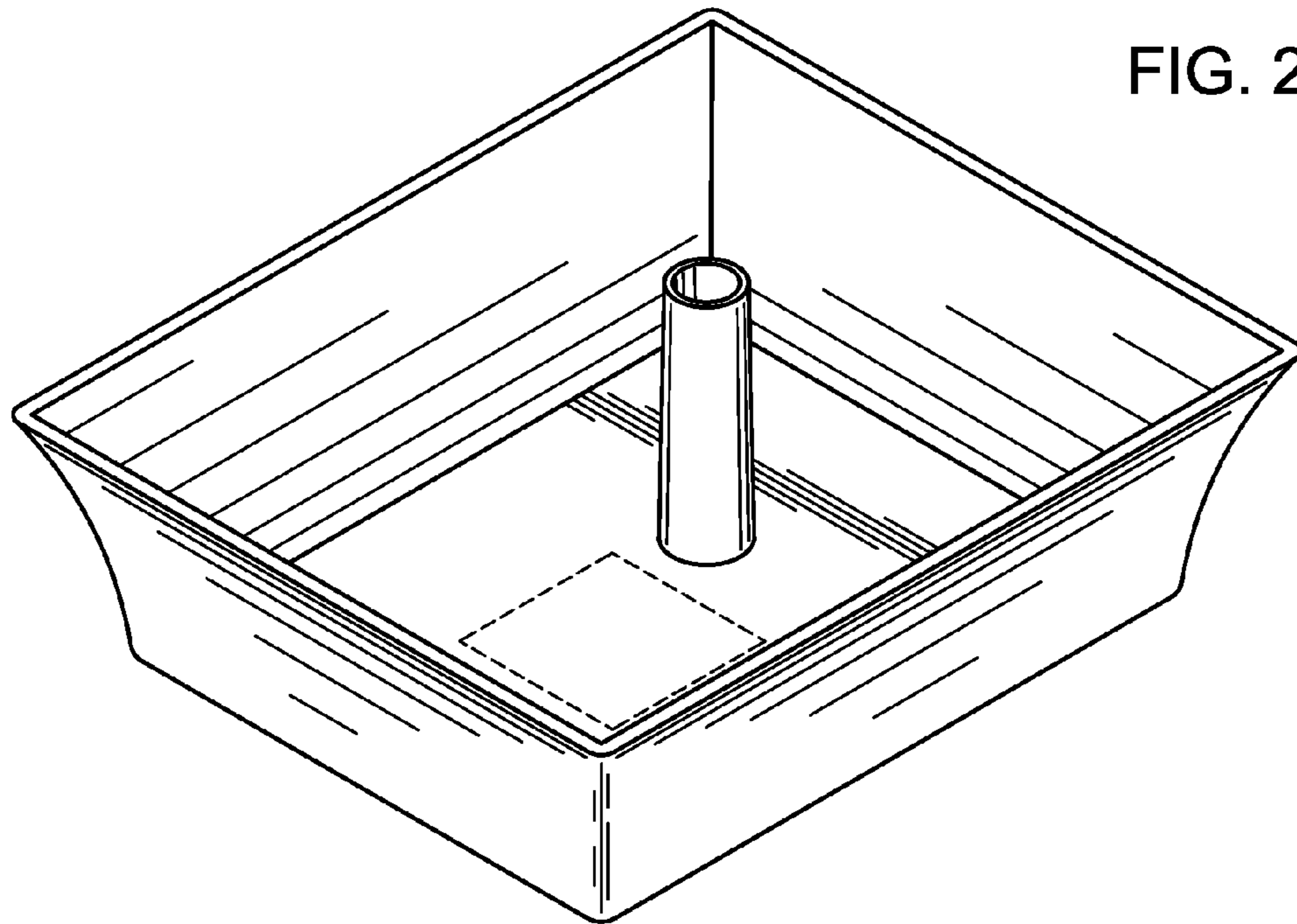

FIG. 2

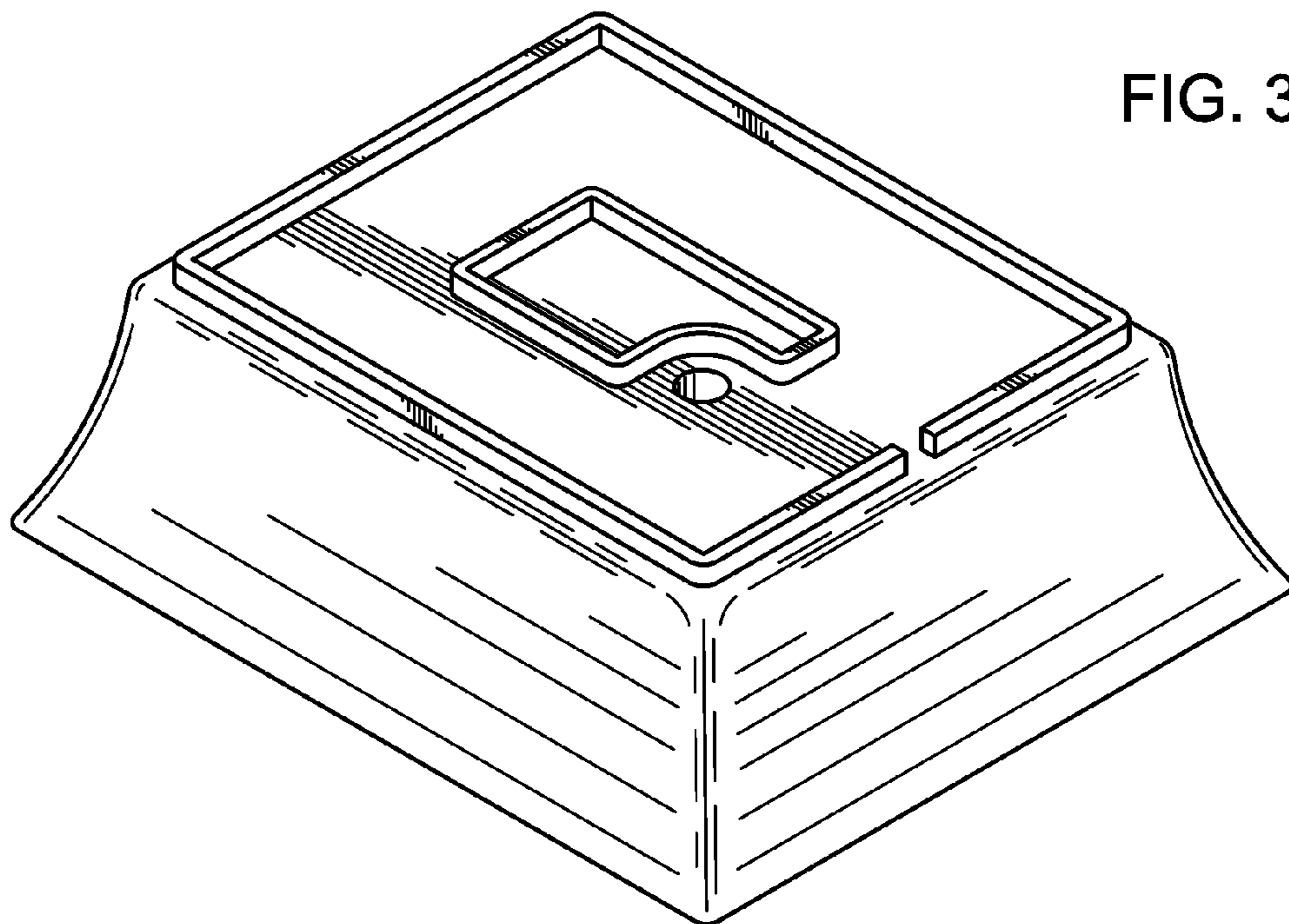

FIG. 3

FIG. 4

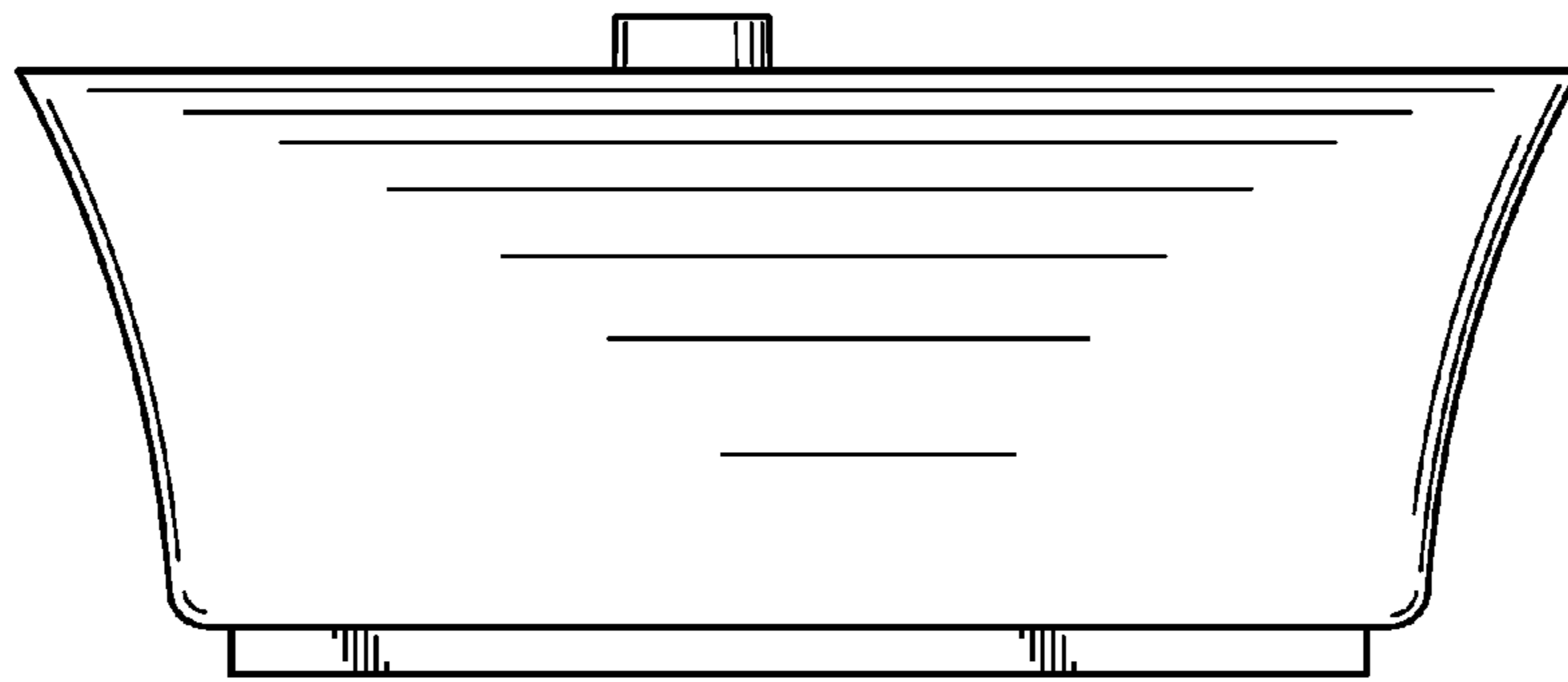

FIG. 5

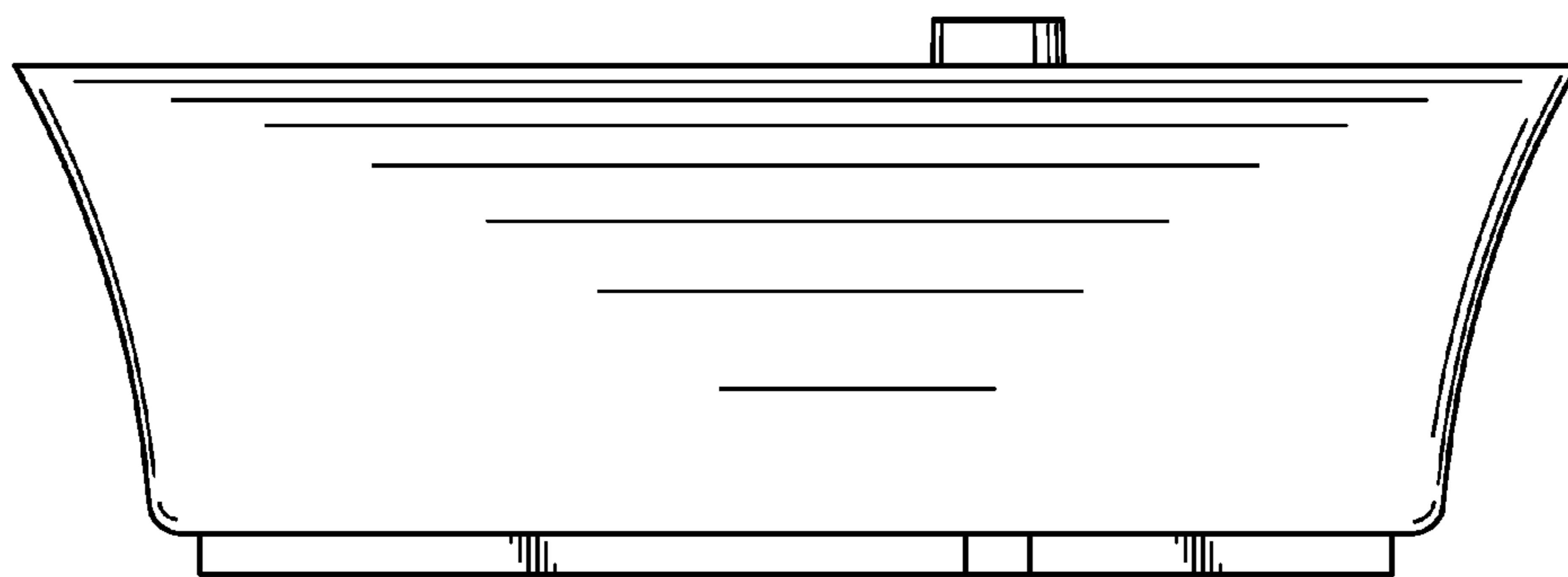

FIG. 6

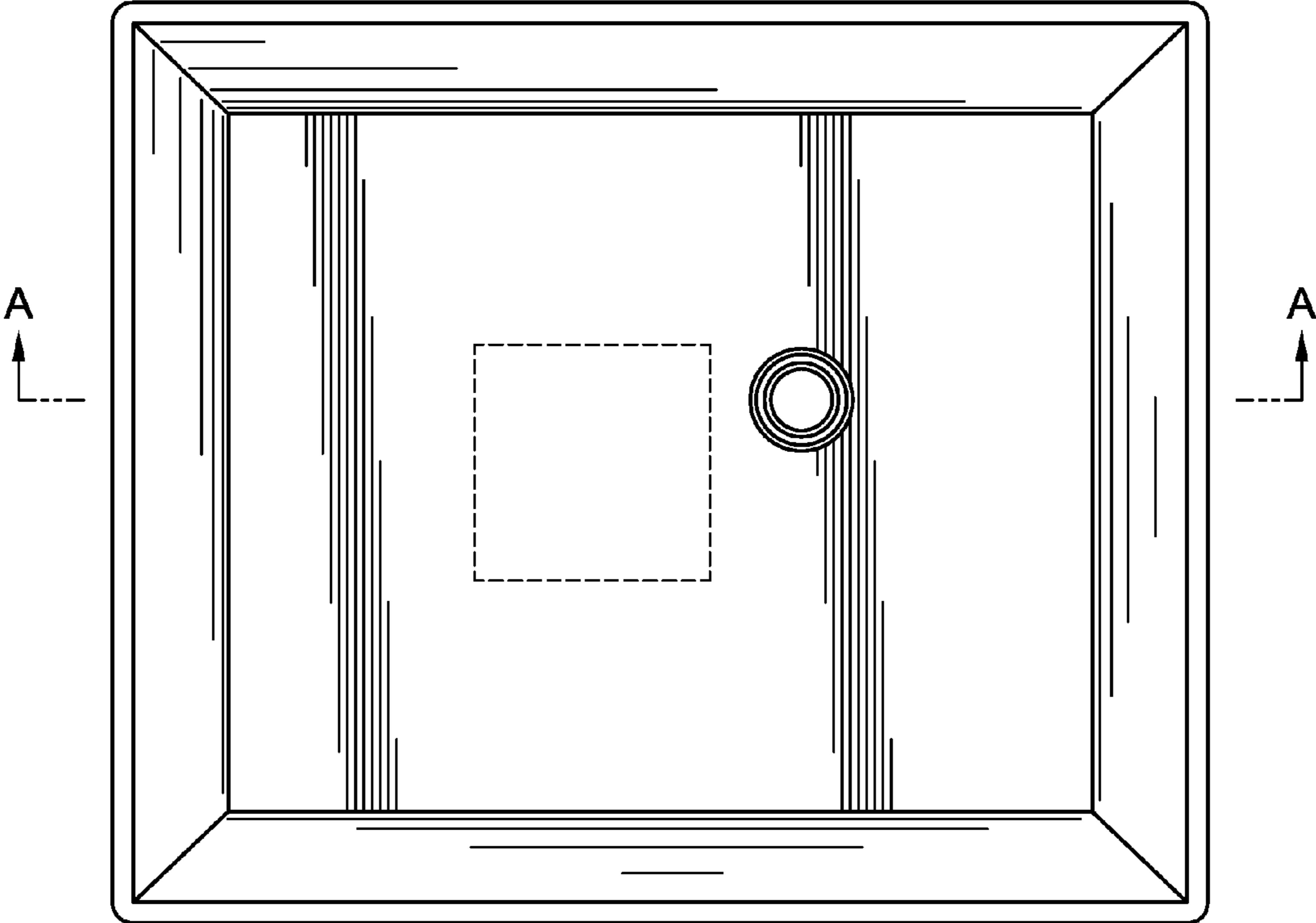

FIG. 7

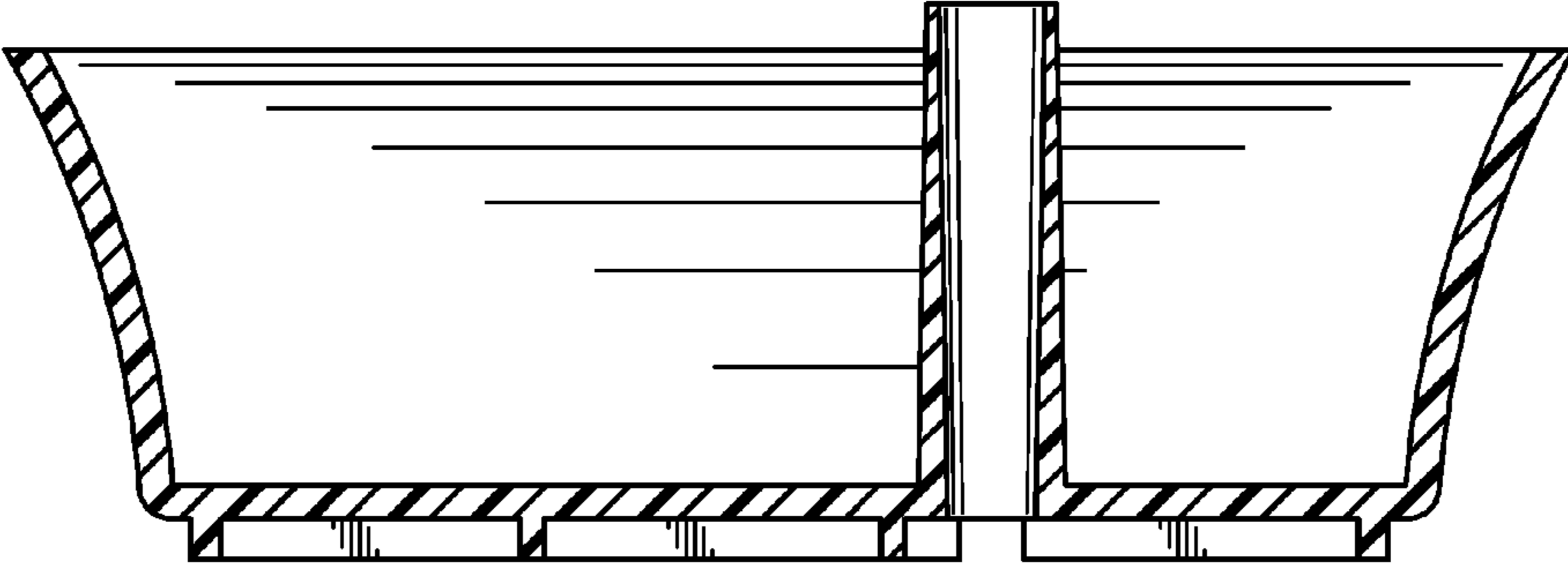



FIG. 8

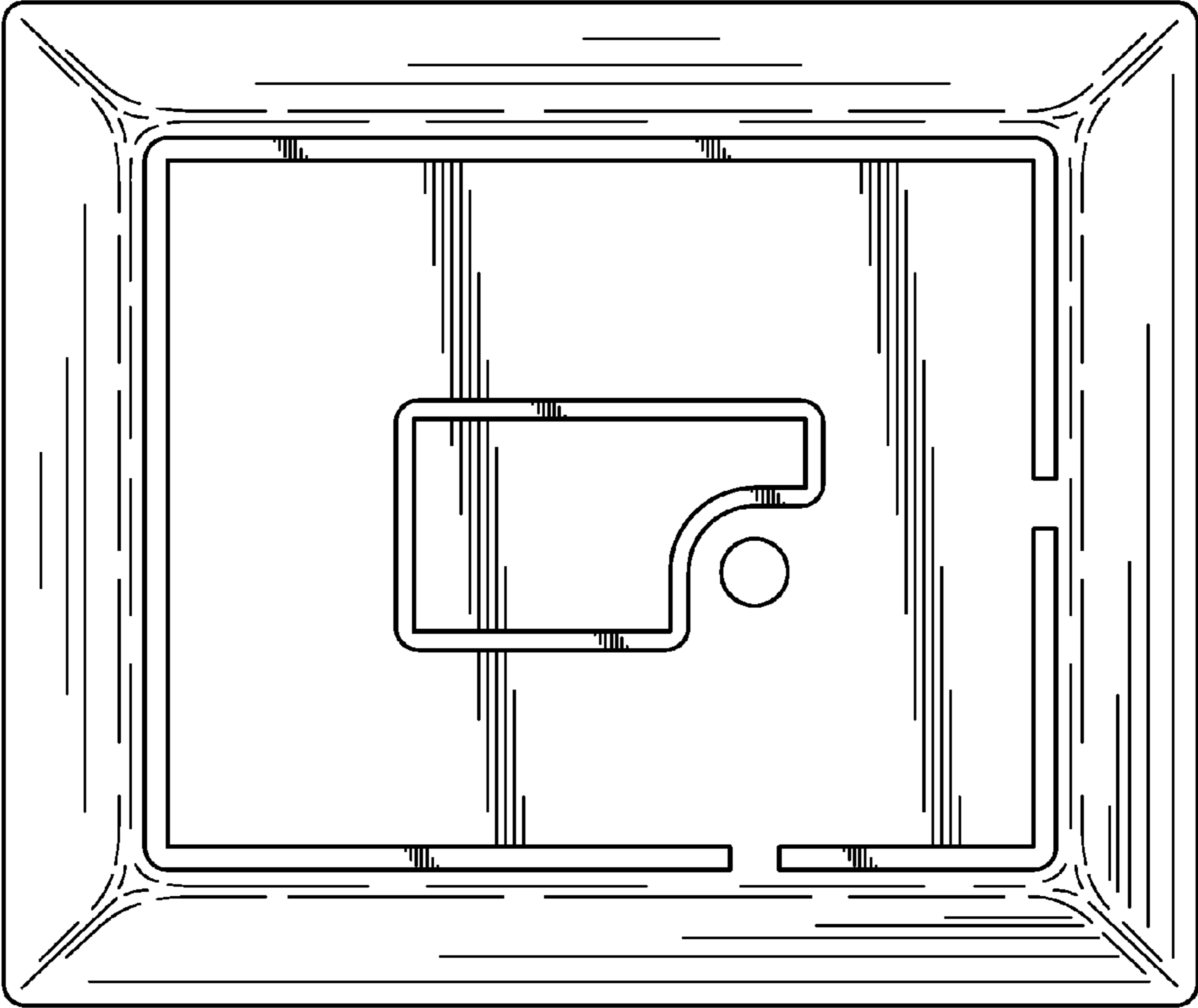

FIG. 9

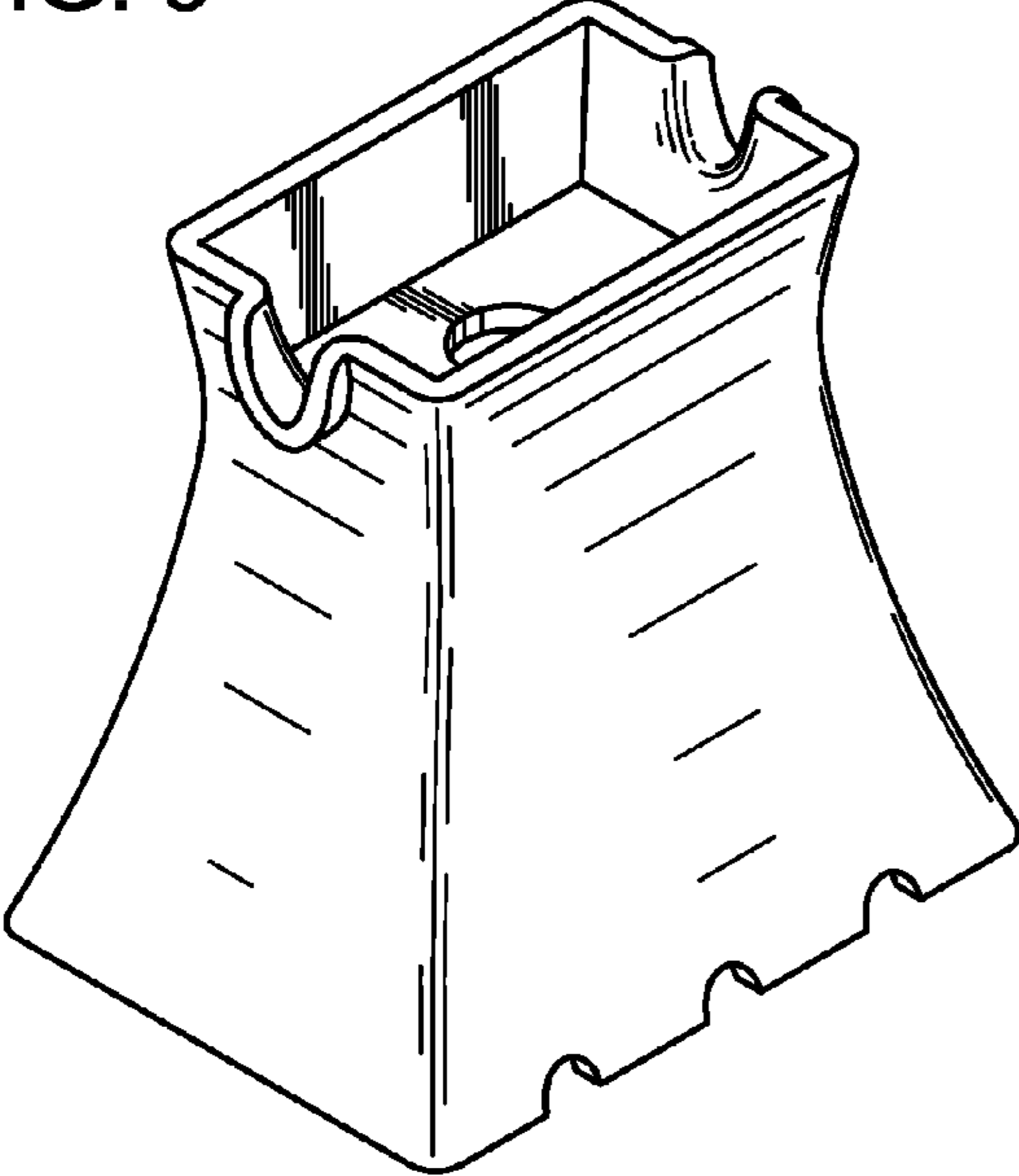

FIG. 10

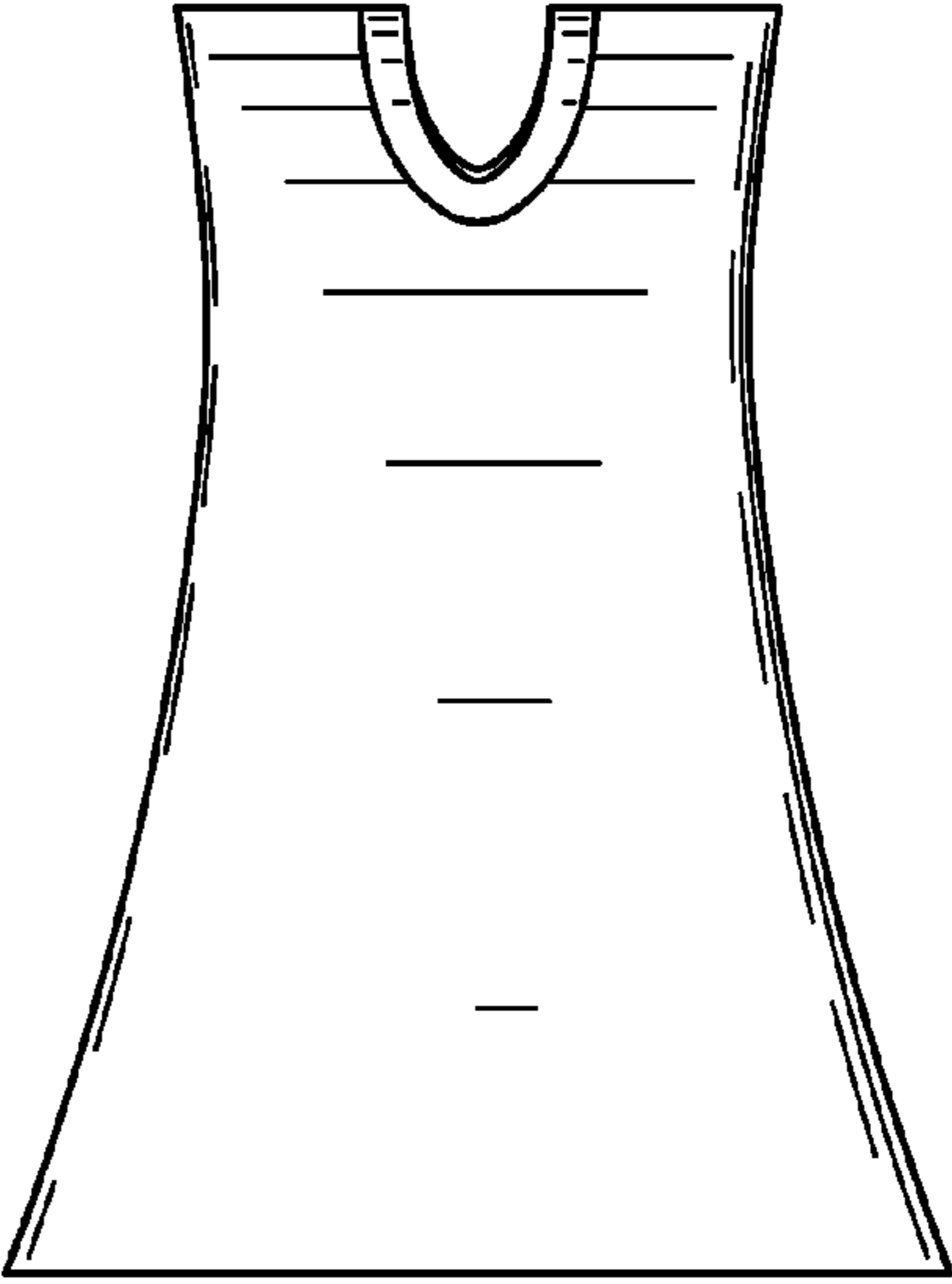



FIG. 11

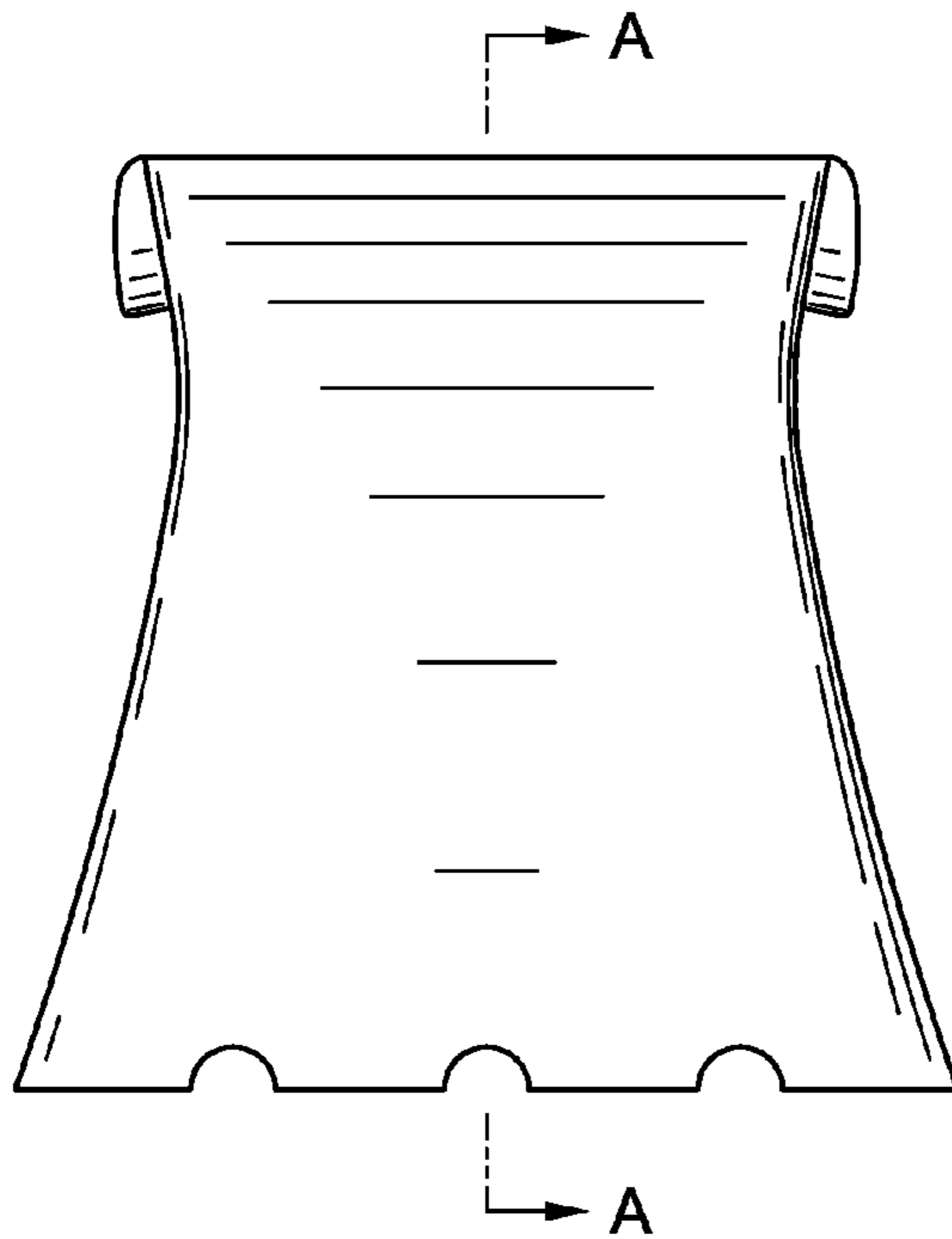

FIG. 13

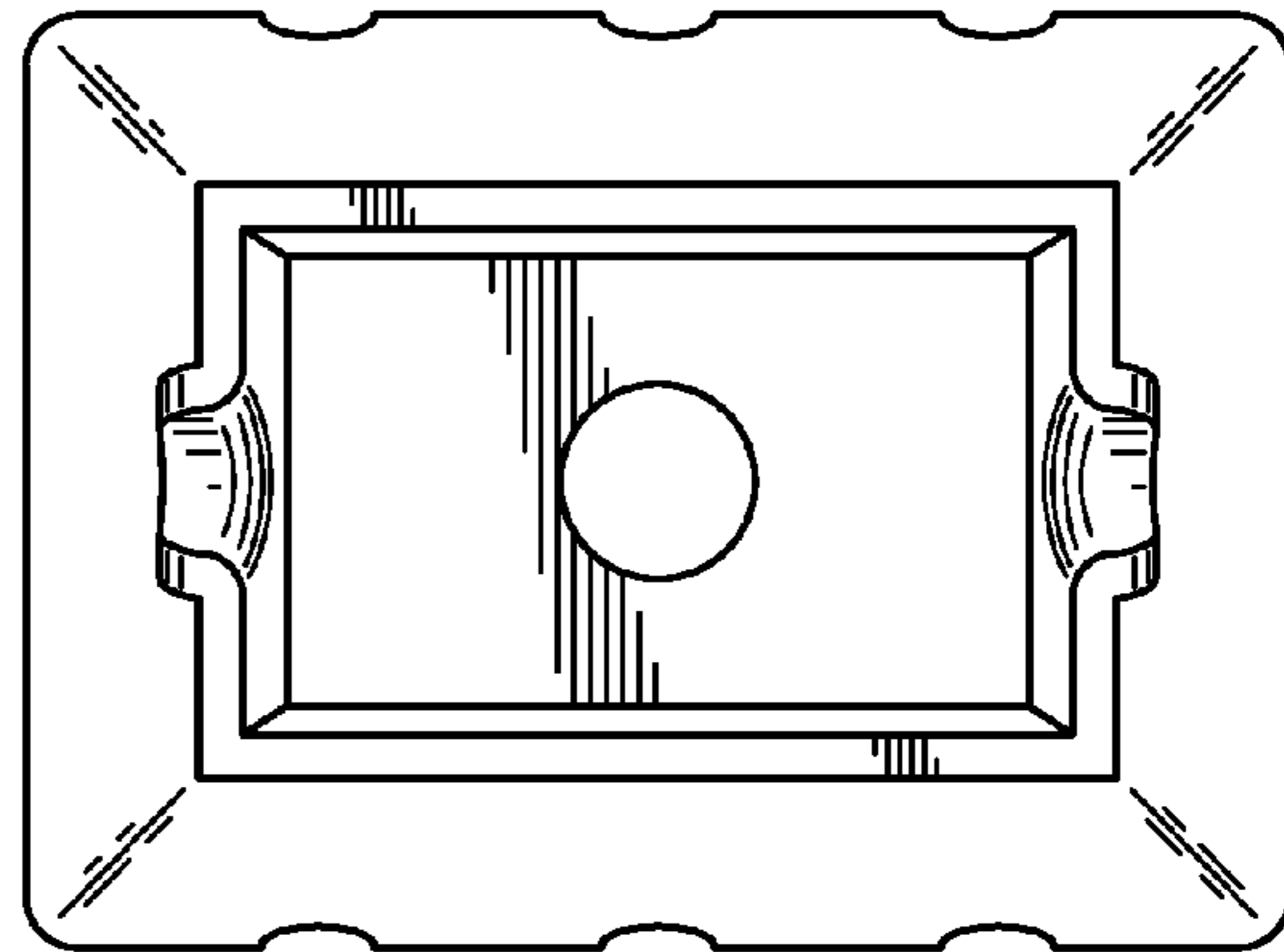

FIG. 12

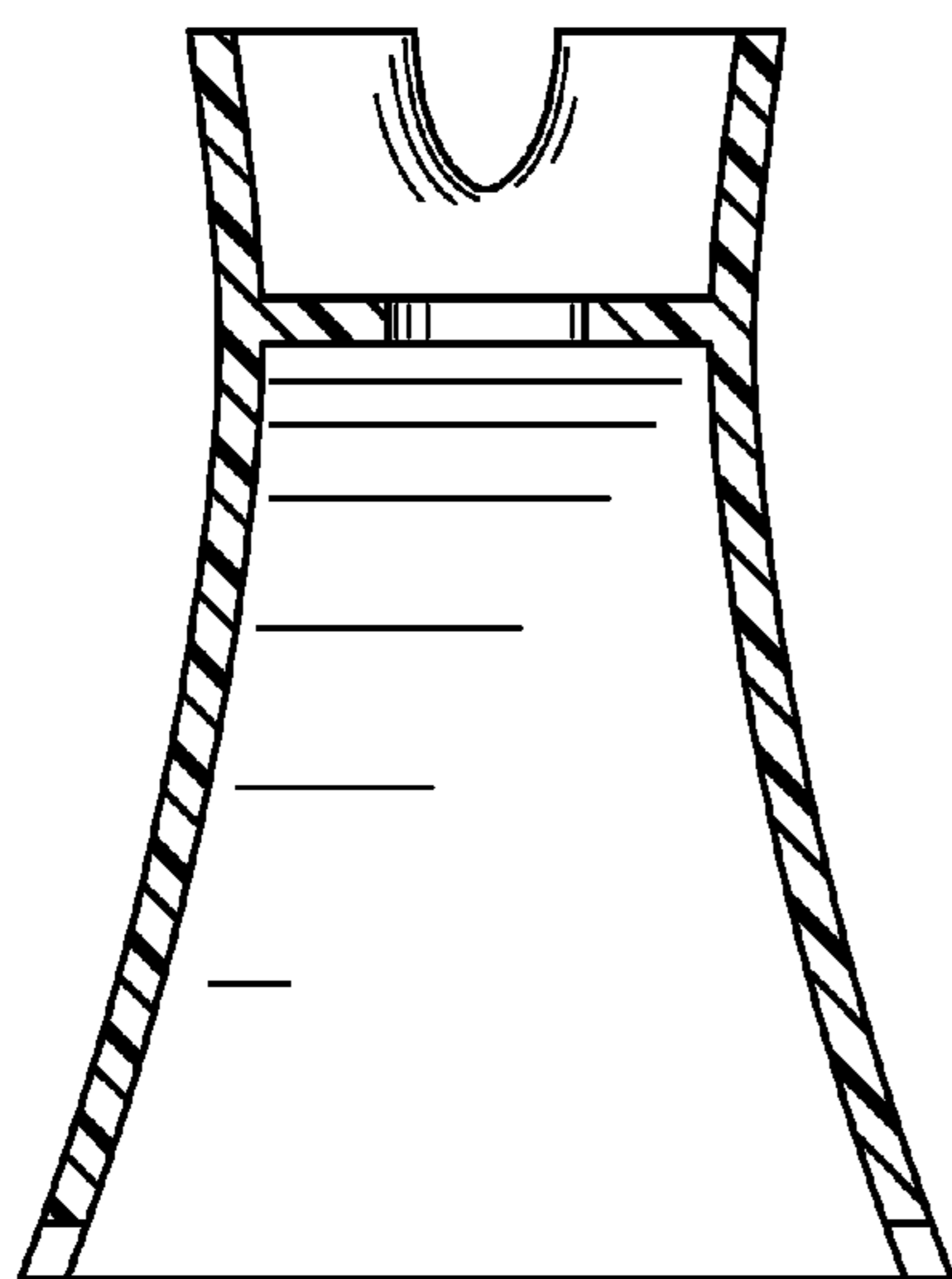

FIG. 14

