



US00D688999S

(12) **United States Design Patent**
Matsumoto et al.

(10) **Patent No.:** **US D688,999 S**
(45) **Date of Patent:** **** Sep. 3, 2013**

(54) **AUTOMOBILE AND/OR TOY REPLICA THEREOF**

(75) Inventors: **Kengo Matsumoto**, Nagoya (JP);
Shinichi Hiranaka, Miyoshi (JP); **Shin Miyata**, Nissin (JP); **Satoru Sugimoto**, Toyota (JP)

(73) Assignee: **Toyota Jidosha Kabushiki Kaisha** (JP)

(**) Term: **14 Years**

(21) Appl. No.: **29/426,329**

(22) Filed: **Jul. 3, 2012**

Related U.S. Application Data

(62) Division of application No. 29/388,894, filed on Apr. 4, 2011.

(30) **Foreign Application Priority Data**

Oct. 6, 2010 (JP) 2010-023940
Jan. 7, 2011 (JP) 2011-000247
Jan. 7, 2011 (JP) 2011-000248
Jan. 7, 2011 (JP) 2011-000252

(51) **LOC (9) Cl.** **12-08**

(52) **U.S. Cl.**
USPC **D12/190**

(58) **Field of Classification Search**
USPC D12/190, 400, 90, 91, 92, 199, 197,
D12/86, 171, 169, 163, 110, 114; D11/211,
D11/81, 157, 133, 172; D20/11, 23, 24,
D20/25, 30, 31, 32; 293/102, 115; 40/413,
40/591, 592; 428/31

See application file for complete search history.

(56) **References Cited**

U.S. PATENT DOCUMENTS

D501,435 S * 2/2005 Hosoda et al. D12/163
D536,284 S * 2/2007 Nakamura et al. D12/163

(Continued)

OTHER PUBLICATIONS

2009 Audi A6, www.netcarshow.com, posted by NetCarShow at least as early as 2009.

(Continued)

Primary Examiner — Katrina A Betton

(74) *Attorney, Agent, or Firm* — SAIDMAN Designlaw Group

(57) **CLAIM**

The ornamental design for an automobile and/or toy replica thereof, as shown and described.

DESCRIPTION

FIG. 1 is a perspective view of an automobile and/or toy replica thereof showing our new design;
FIG. 2 is a front view thereof;
FIG. 3 is a rear view thereof;
FIG. 4 is a top view thereof;
FIG. 5 is a left side view thereof;
FIG. 6 is an enlarged view showing a portion of FIG. 1 defined by line 6-6;
FIG. 7 is an enlarged view showing a portion of FIG. 5 defined by lines 7-7;
FIG. 8 is a perspective view of a second embodiment thereof;
FIG. 9 is a front view thereof;
FIG. 10 is a rear view thereof;
FIG. 11 is a top view thereof;
FIG. 12 is a left side view thereof;
FIG. 13 is an enlarged view showing a portion of FIG. 8 defined by line 13-13; and,
FIG. 14 is an enlarged view showing a portion of FIG. 12 defined by lines 14-14.
The broken lines illustrate portions of the automobile and/or toy replica thereof and form no part of the claimed design.

1 Claim, 9 Drawing Sheets

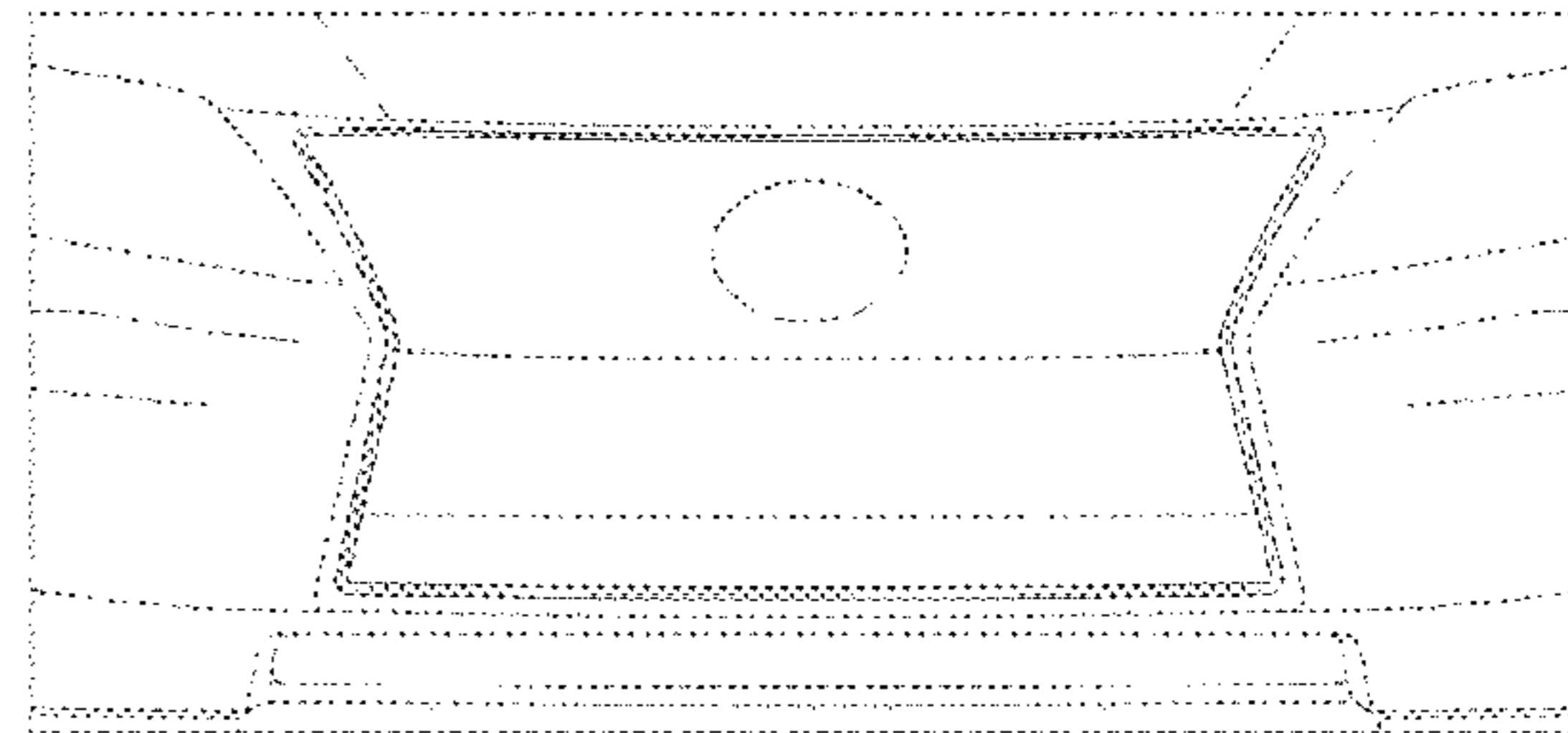
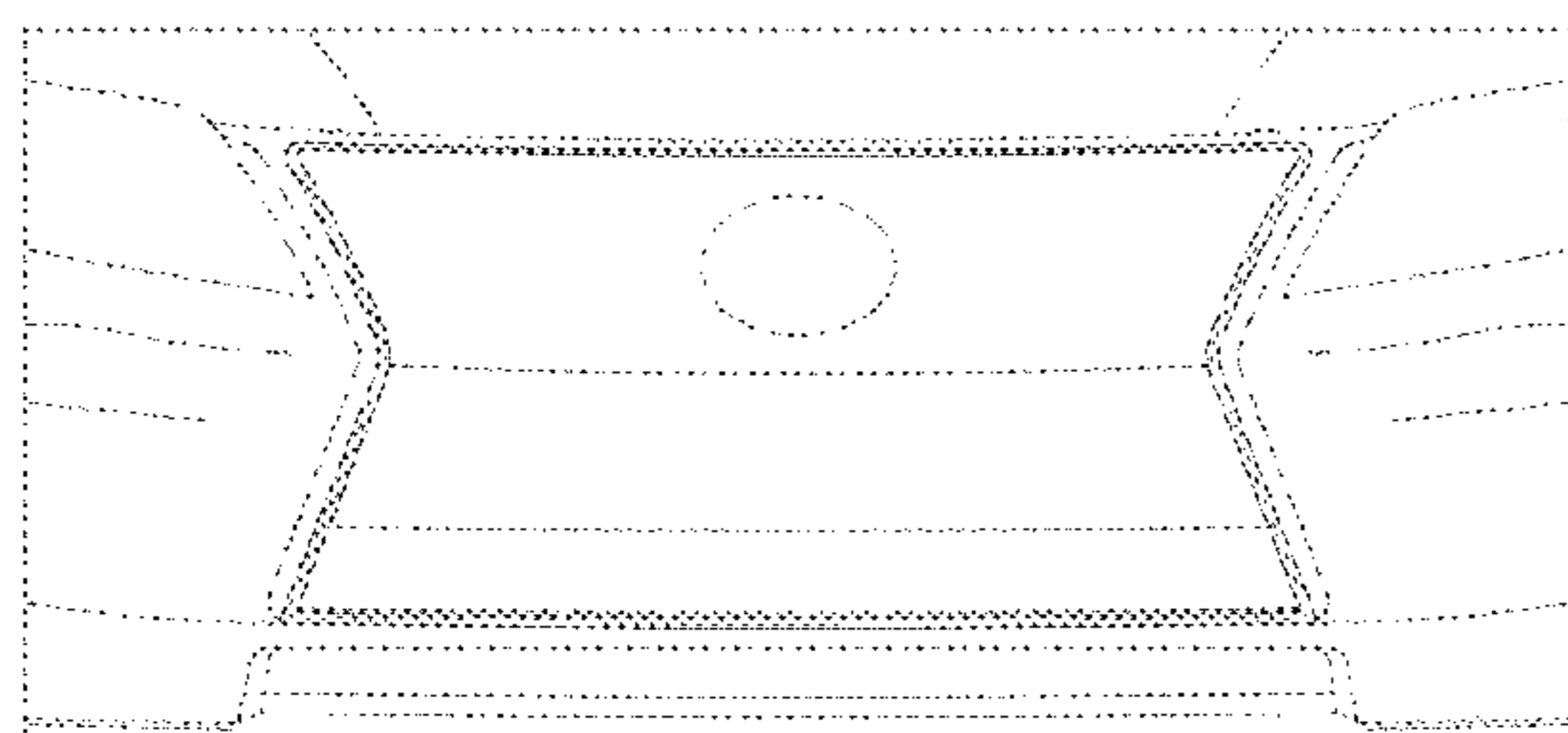

US D688,999 S

Page 2

(56)

References Cited

U.S. PATENT DOCUMENTS

D538,716 S * 3/2007 Hogios D12/163
D539,196 S * 3/2007 Pfeiffer D12/163
D539,707 S * 4/2007 Golden et al. D12/163
D578,444 S * 10/2008 Kuo D12/163
D587,636 S * 3/2009 Kanno et al. D12/163
D592,560 S * 5/2009 Bauer et al. D12/163

D596,088 S * 7/2009 Camacho et al. D12/163
D605,989 S * 12/2009 Leng et al. D12/163
2006/0119115 A1* 6/2006 Filip et al. 293/115

OTHER PUBLICATIONS

2011 Lexus CT200h, www.netcarshow.com, publicly known at least as early as Mar. 2010.

* cited by examiner

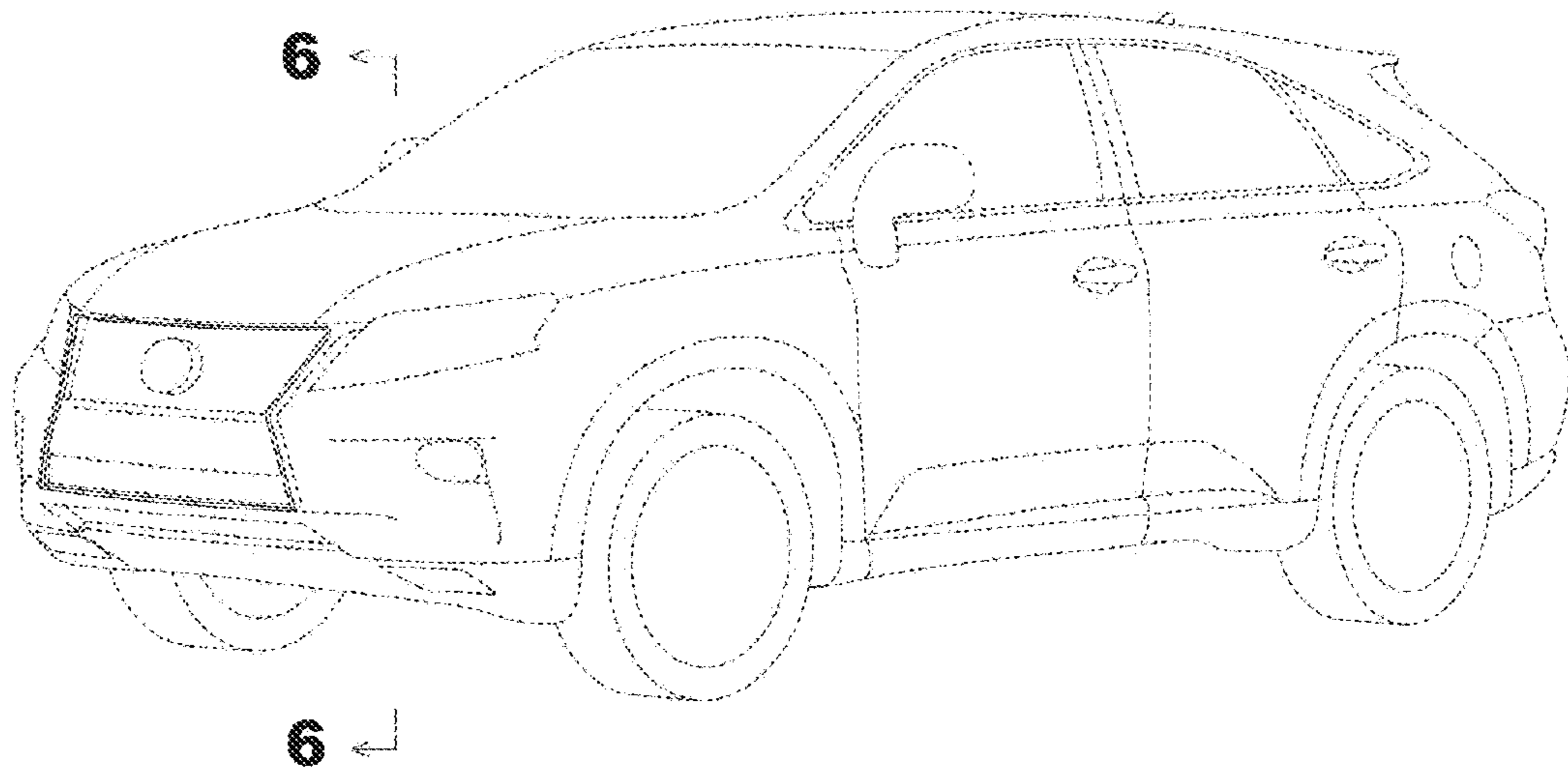

FIG. 1

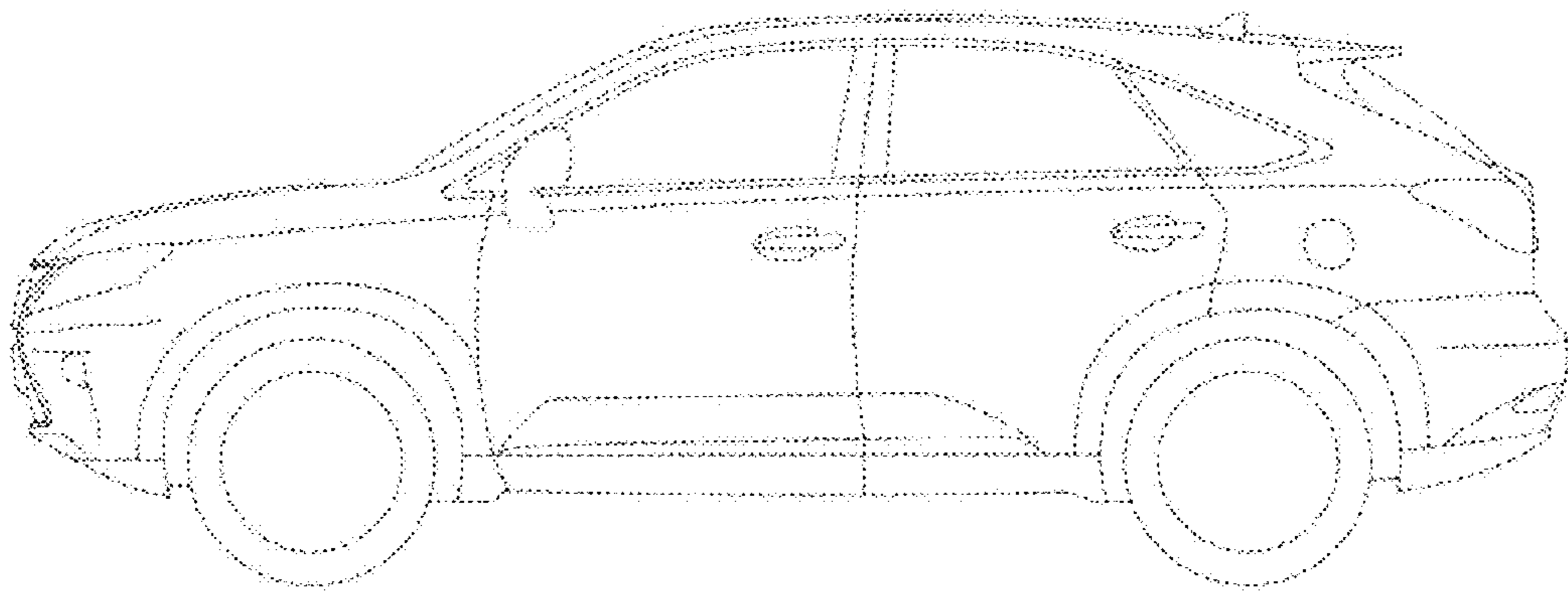

FIG. 2

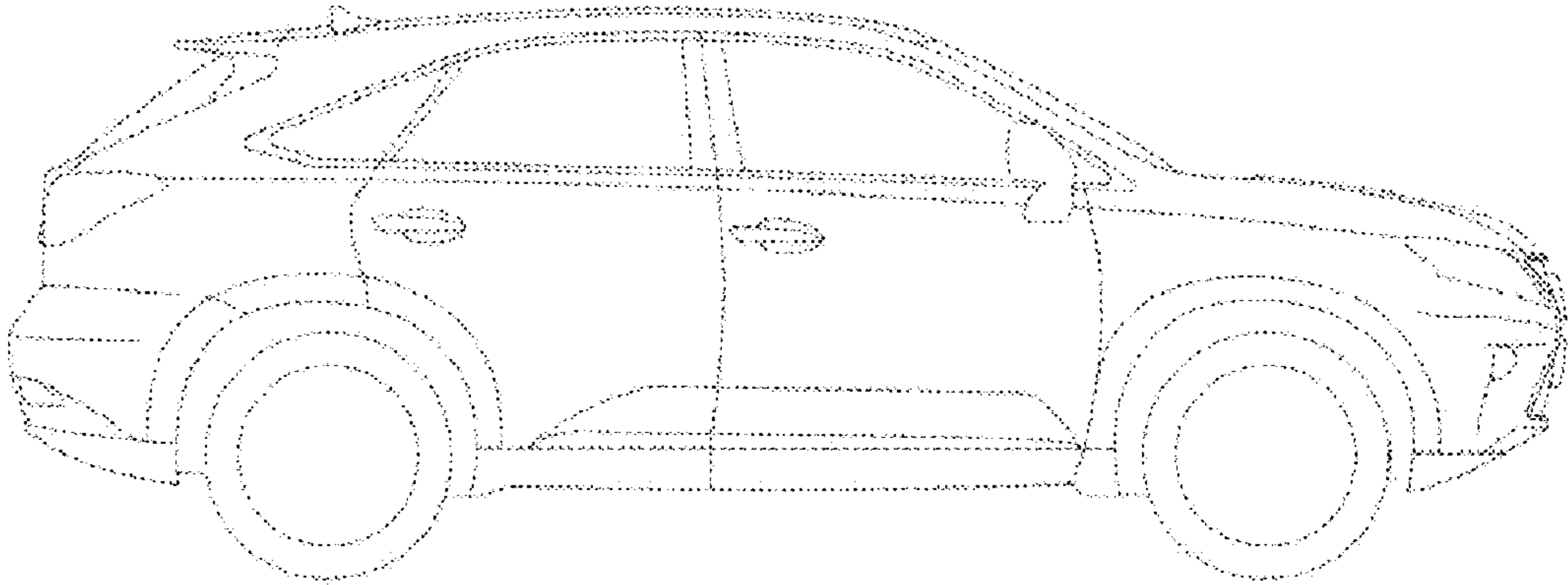

FIG. 3

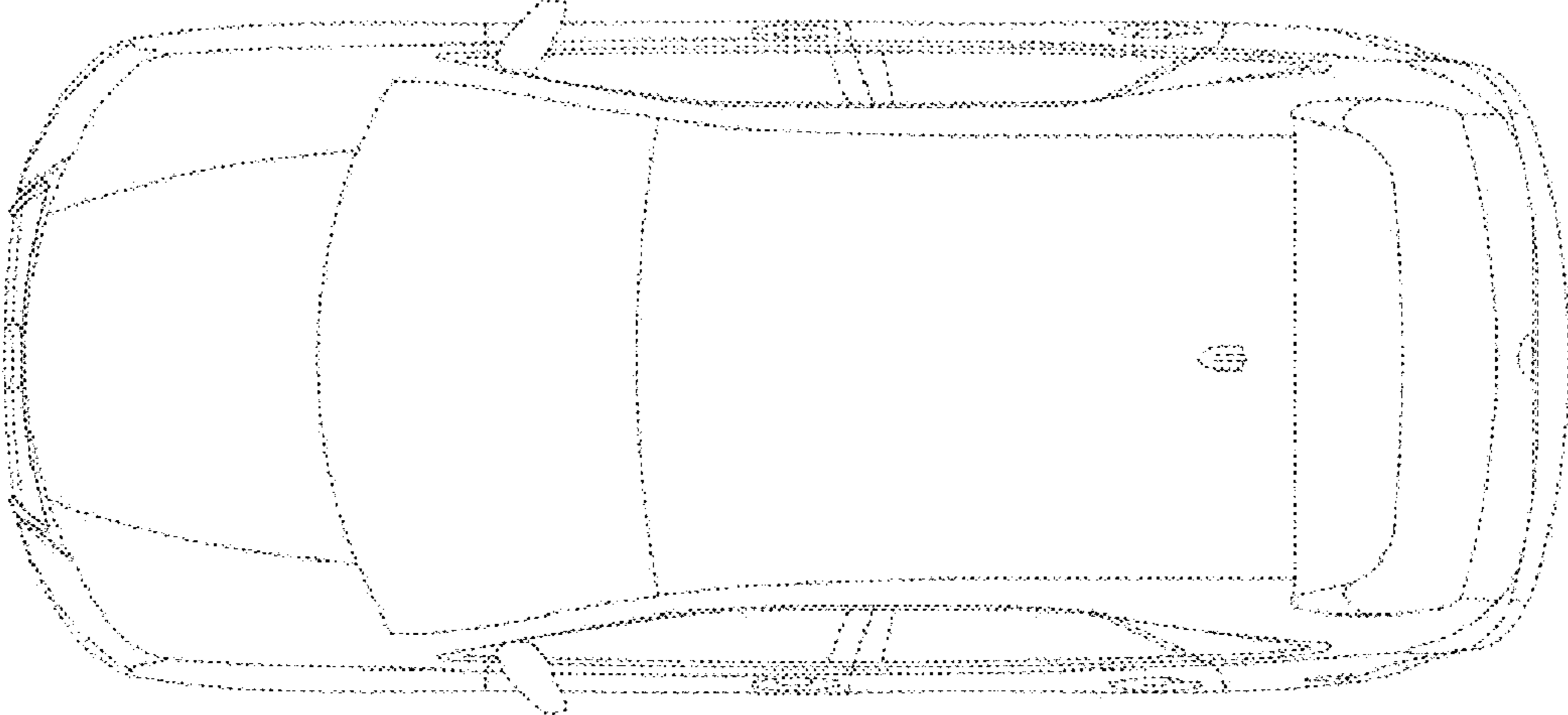

FIG. 4

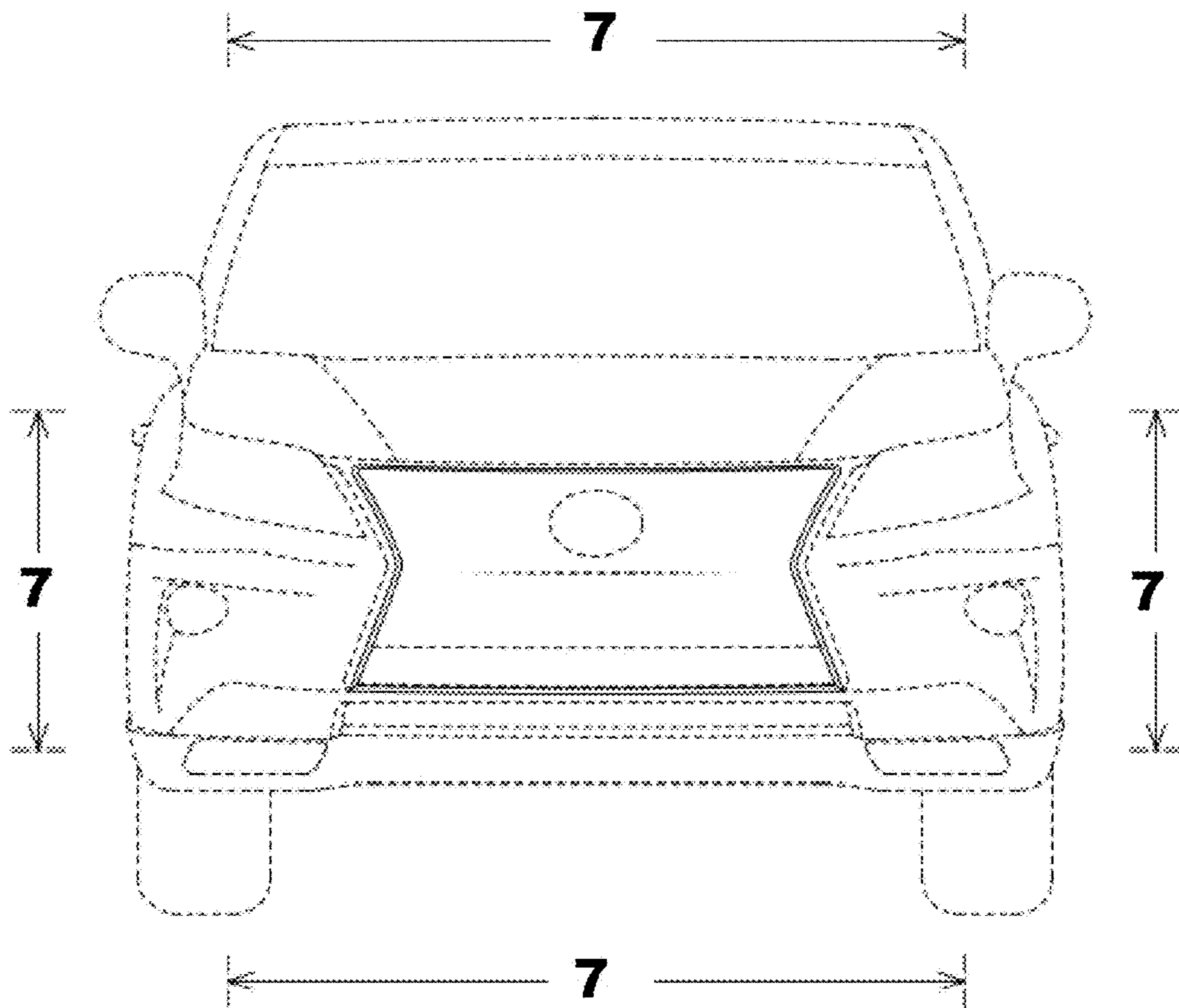

FIG. 5

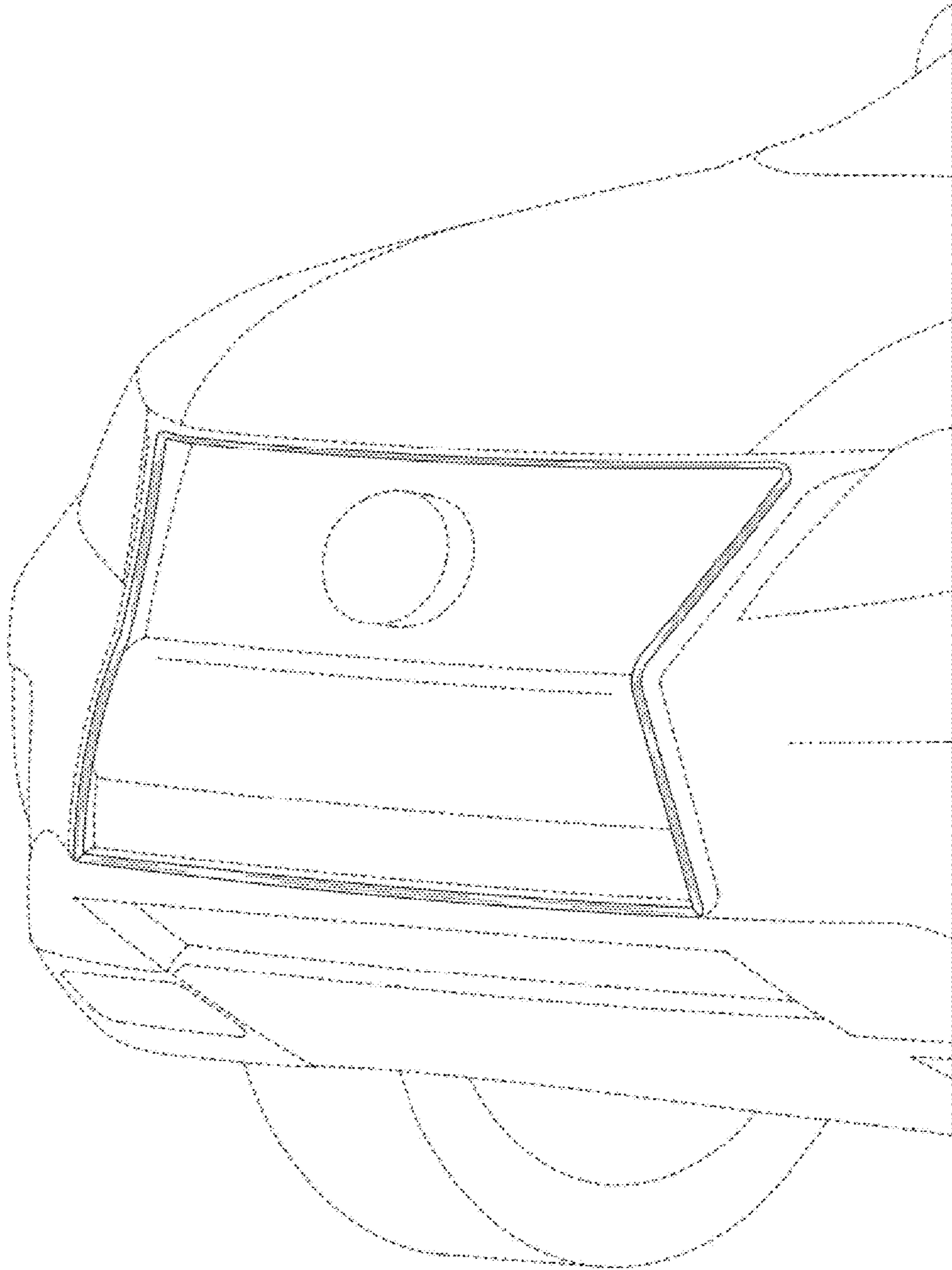

FIG. 6

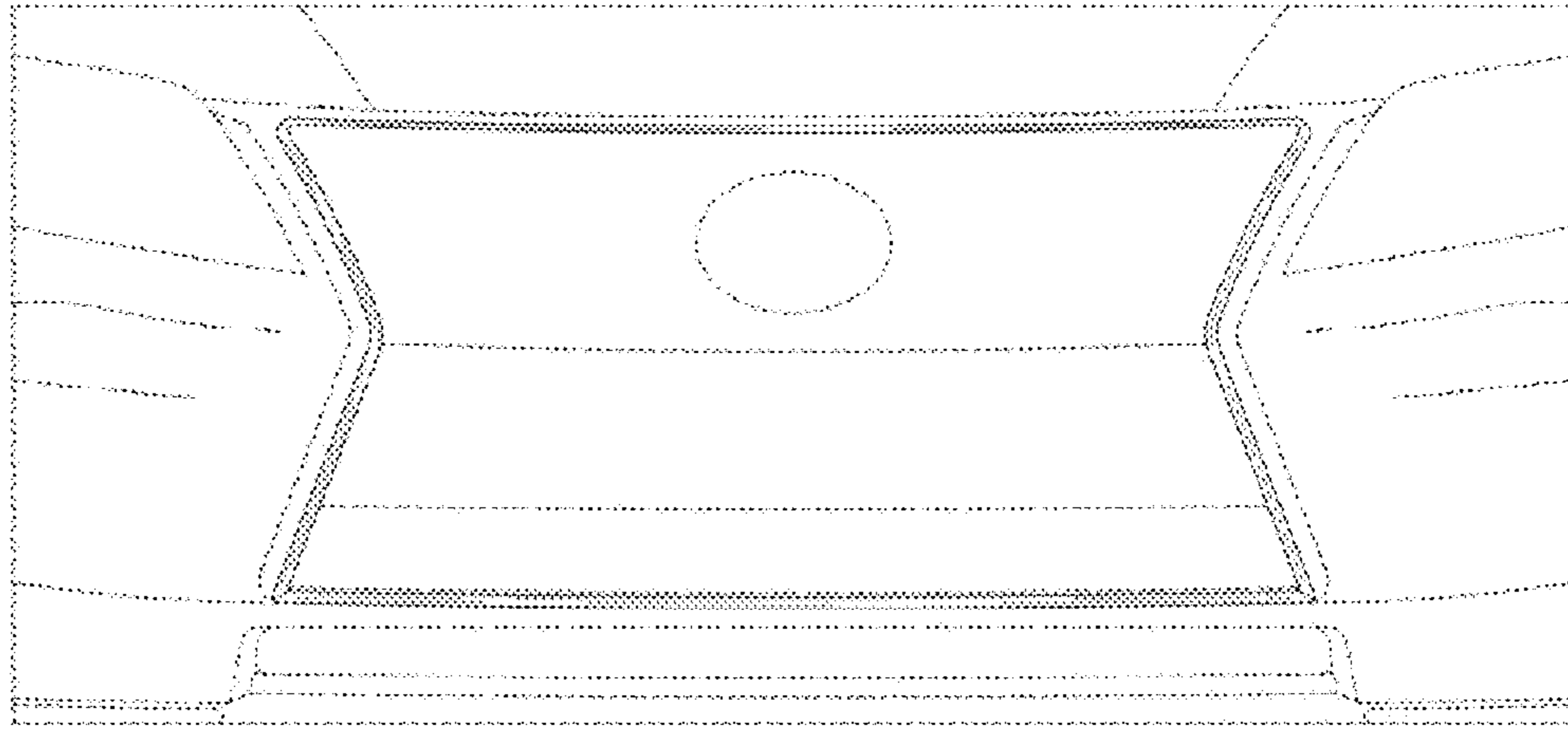

FIG. 7

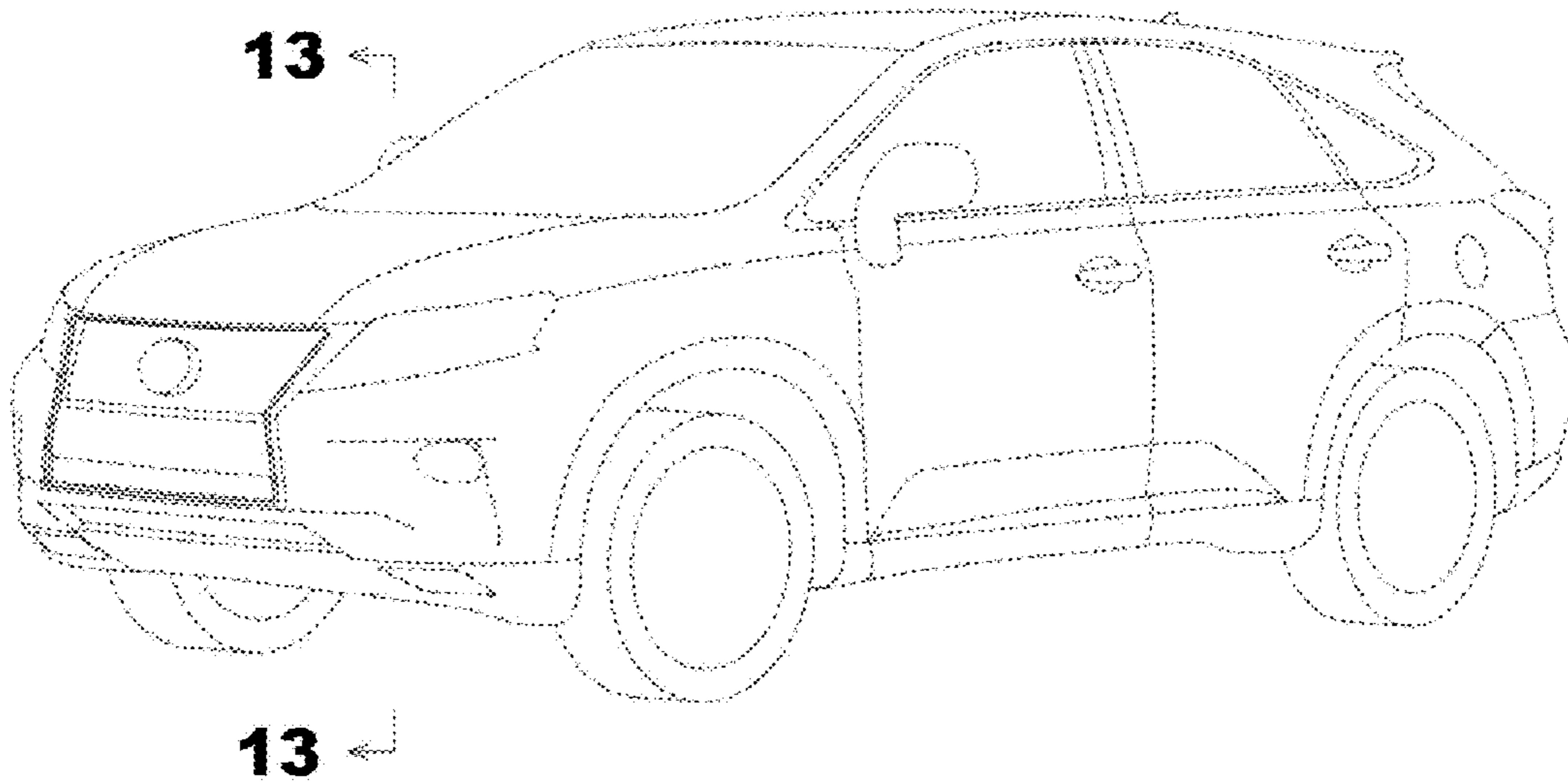

FIG. 8

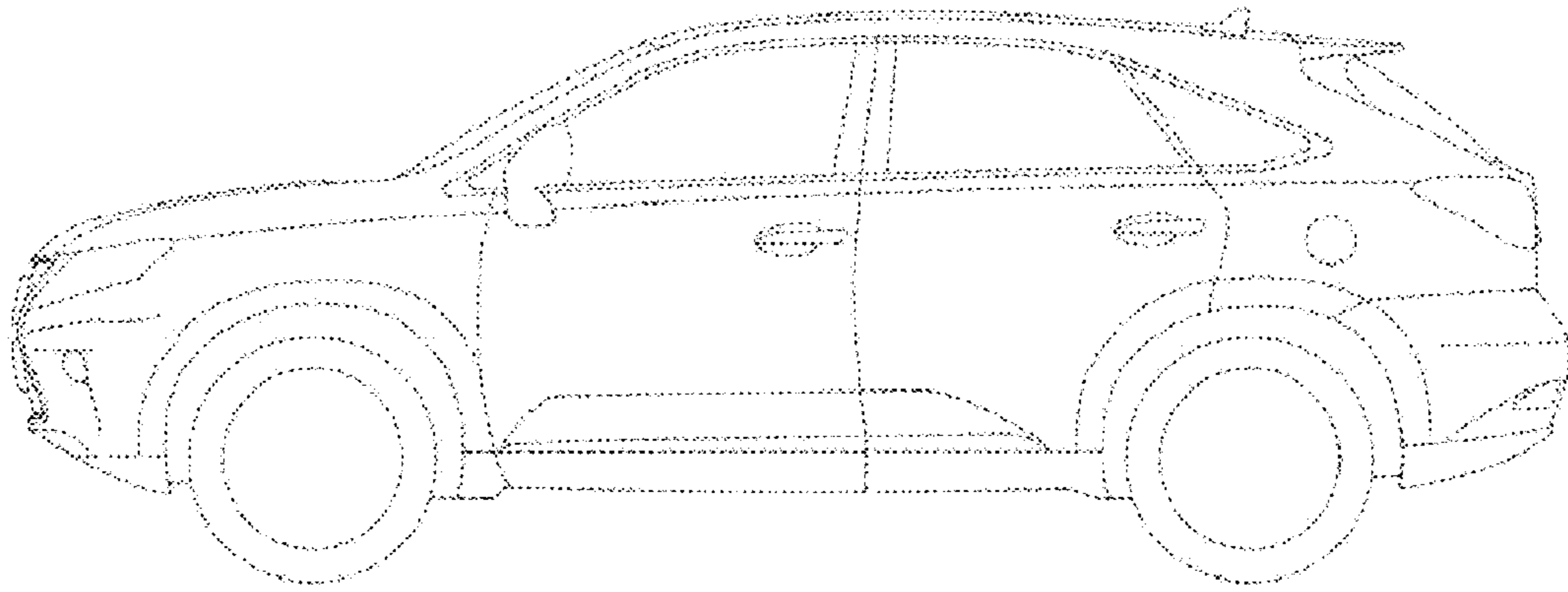

FIG. 9

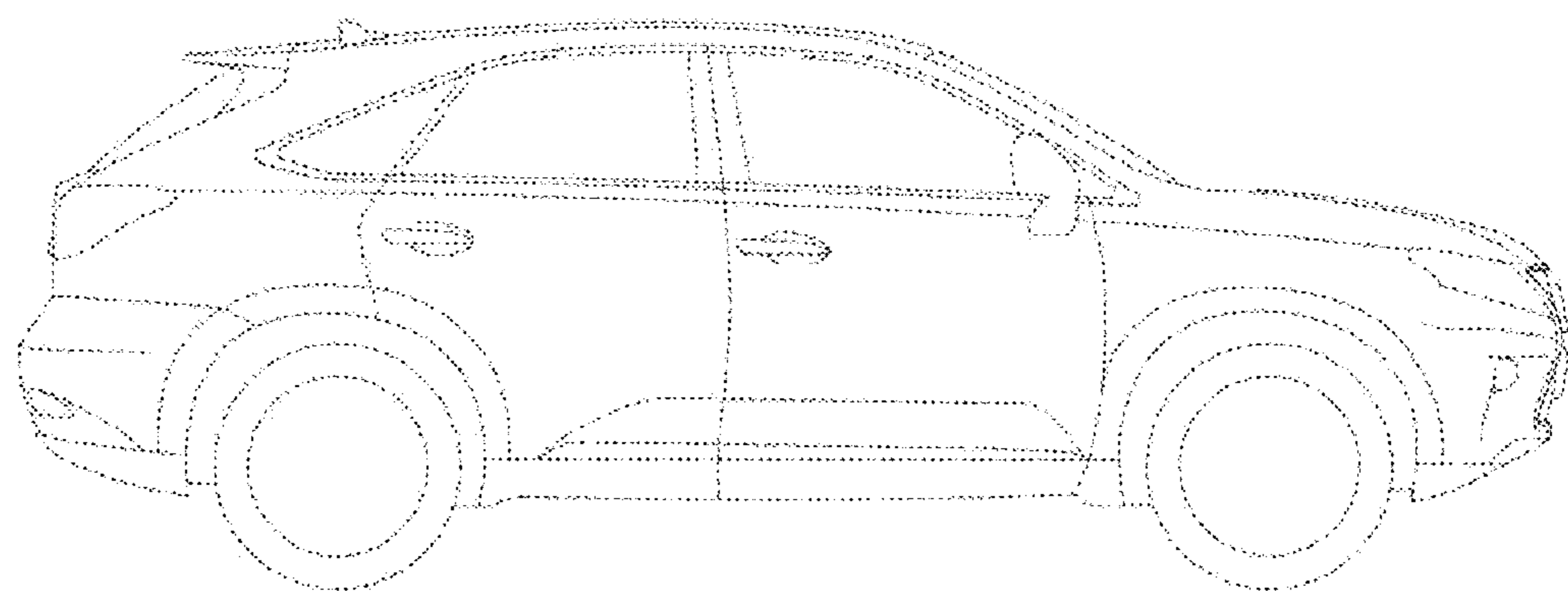

FIG. 10

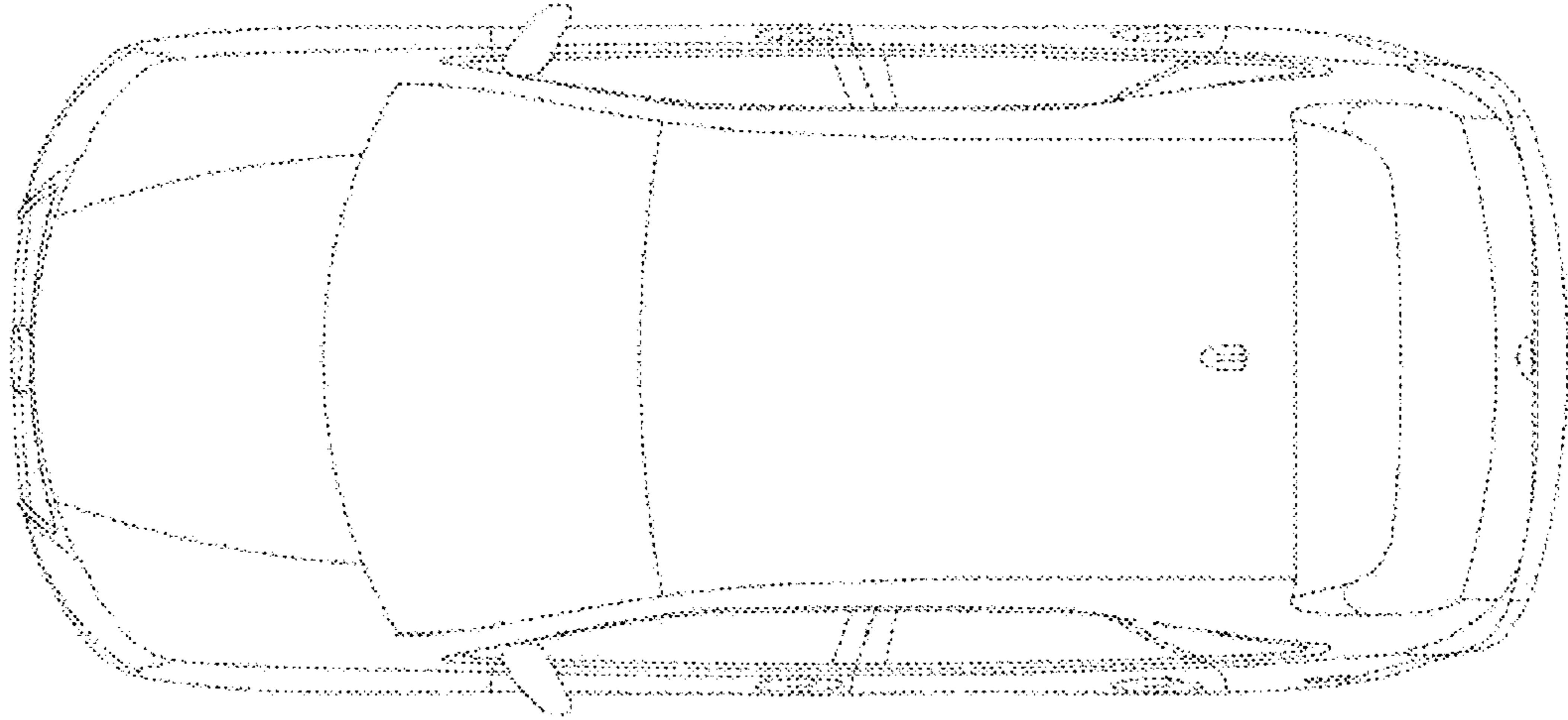

FIG. 11

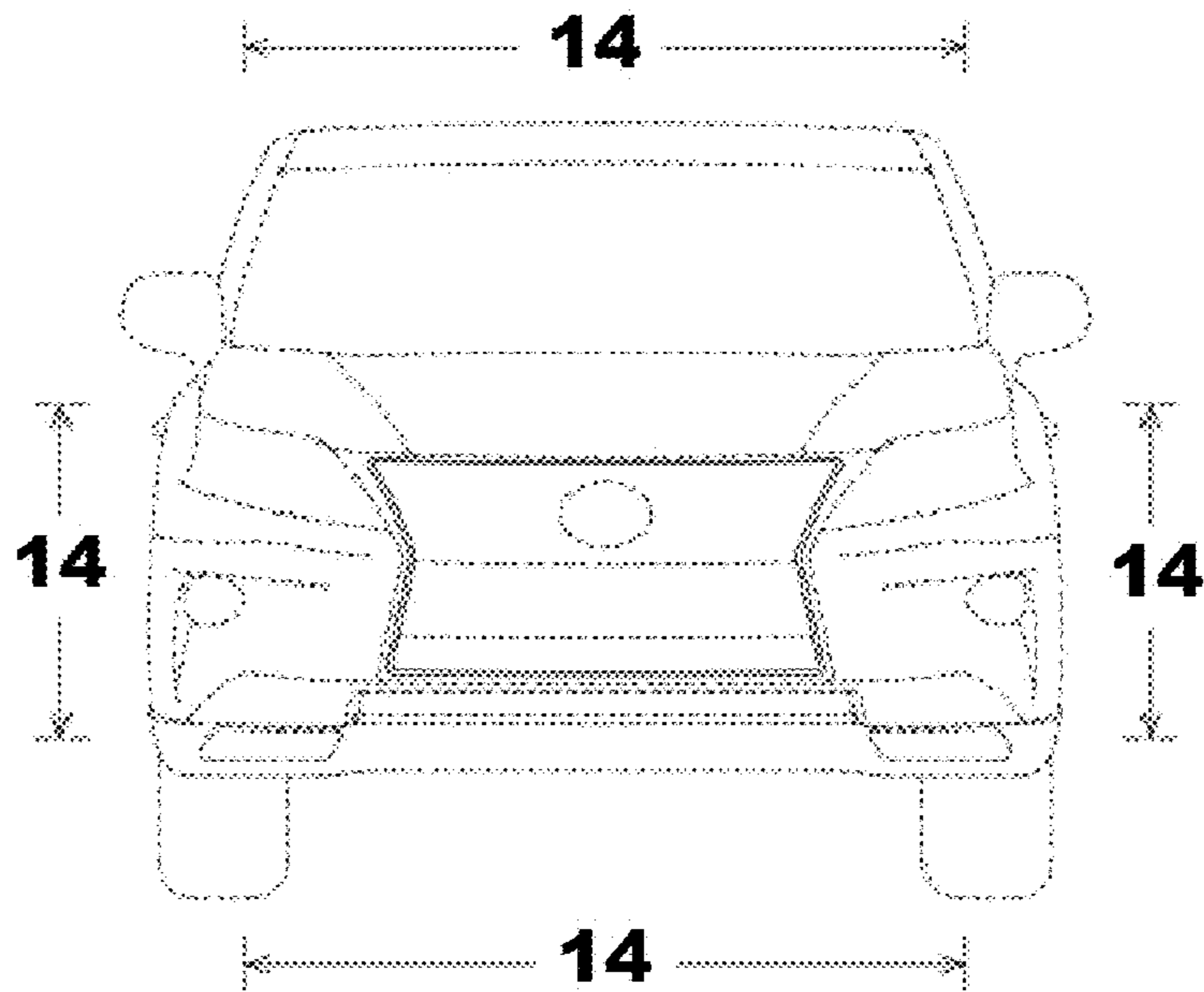

FIG. 12

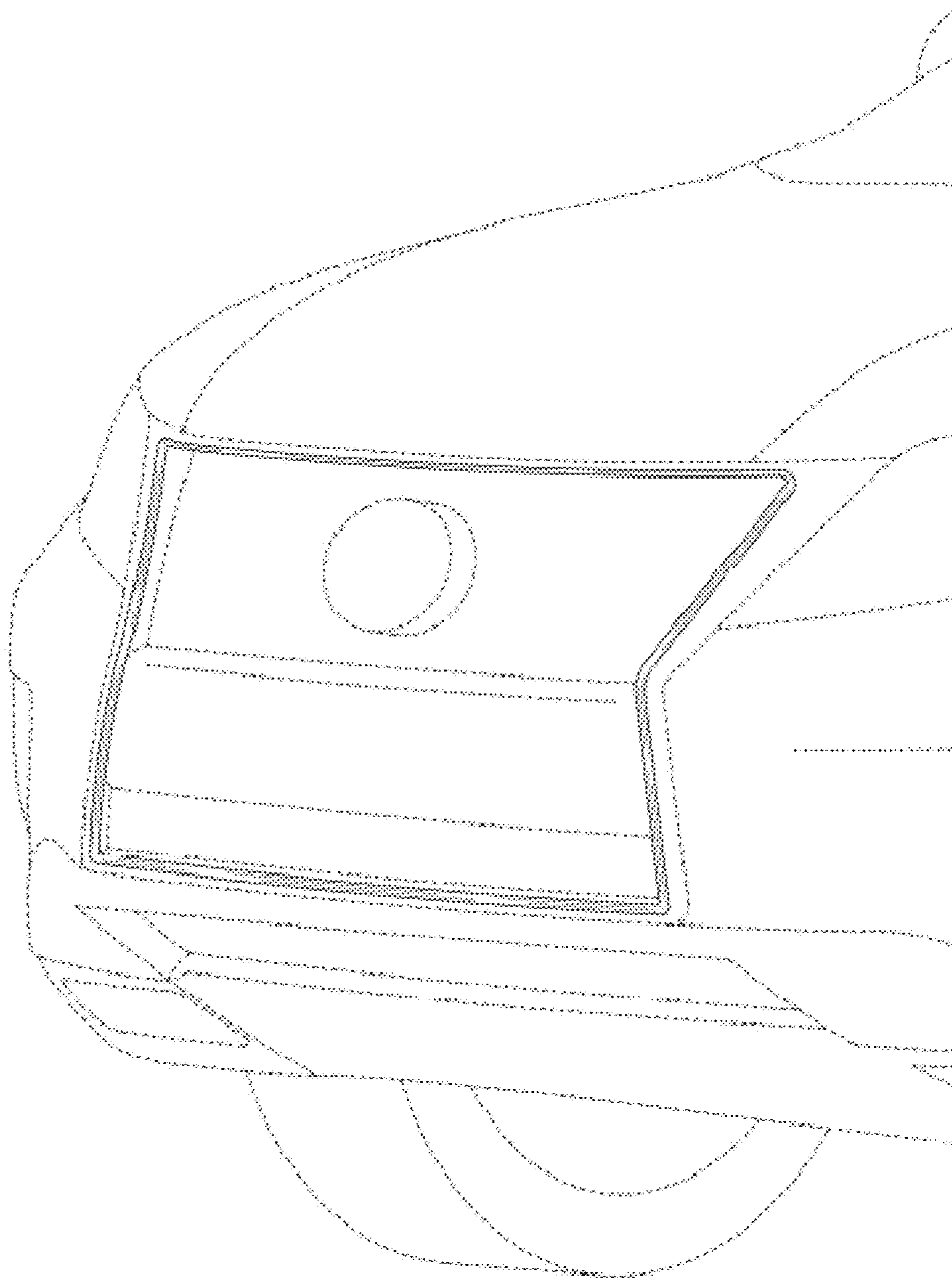

FIG. 13

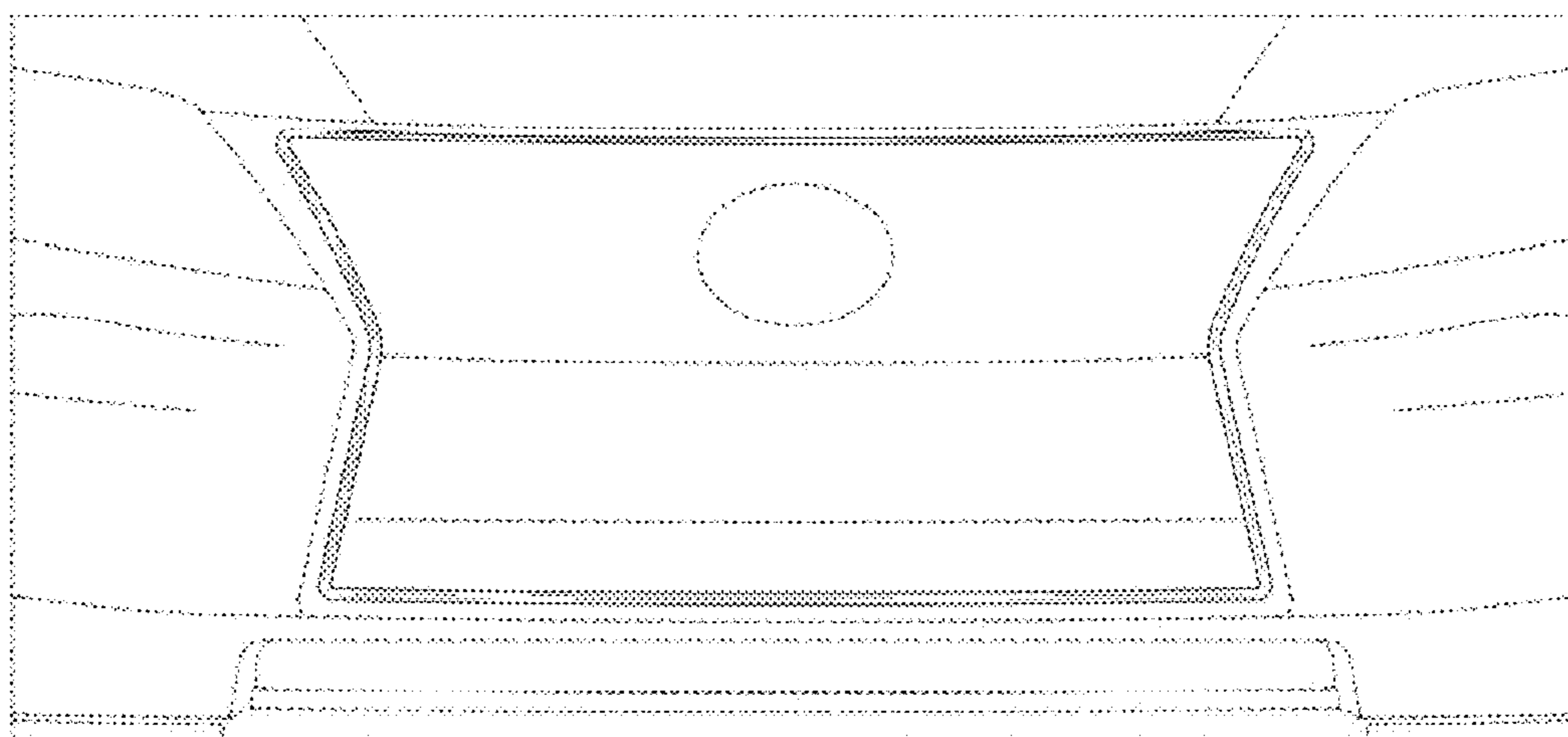

FIG. 14