



US00D688982S

(12) **United States Design Patent**  
**Oyanagi et al.**

(10) **Patent No.:** **US D688,982 S**

(45) **Date of Patent:** **\*\* Sep. 3, 2013**

(54) **MOTORCYCLE**

(71) Applicant: **Kawasaki Jukogyo Kabushiki Kaisha,**  
Hyogo (JP)

(72) Inventors: **Juichi Oyanagi,** Kobe (JP); **Toshiyuki**  
**Nishihara,** Akashi (JP); **Takumi**  
**Uemoto,** Kobe (JP)

(73) Assignee: **Kawasaki Jukogyo Kabushiki Kaisha,**  
Hyogo (JP)

(\*\*) Term: **14 Years**

(21) Appl. No.: **29/442,297**

(22) Filed: **Jan. 25, 2013**

(30) **Foreign Application Priority Data**

Jul. 31, 2012 (JP) ..... 2012-018310

(51) **LOC (9) Cl.** ..... **12-11**

(52) **U.S. Cl.**  
USPC ..... **D12/110**

(58) **Field of Classification Search**  
USPC ..... D12/110; 180/219, 220, 225, 229  
See application file for complete search history.

(56) **References Cited**

U.S. PATENT DOCUMENTS

|          |   |   |         |                 |       |         |
|----------|---|---|---------|-----------------|-------|---------|
| D496,309 | S | * | 9/2004  | Fukumoto et al. | ..... | D12/110 |
| D588,961 | S | * | 3/2009  | Tanaka et al.   | ..... | D12/110 |
| D605,090 | S | * | 12/2009 | Tanaka et al.   | ..... | D12/110 |
| D606,457 | S | * | 12/2009 | Tanaka et al.   | ..... | D12/110 |
| D638,756 | S | * | 5/2011  | Kouchi et al.   | ..... | D12/110 |
| D647,825 | S | * | 11/2011 | Shibuta et al.  | ..... | D12/110 |
| D670,204 | S | * | 11/2012 | Yasuhara et al. | ..... | D12/110 |

\* cited by examiner

*Primary Examiner* — Susan M Lee

*Assistant Examiner* — Linda G Brooks

(57) **CLAIM**

The ornamental design for a motorcycle, as shown and described.

**DESCRIPTION**

FIG. 1 is a front elevational view of a motorcycle showing our new design;

FIG. 2 is a rear elevational view thereof;

FIG. 3 is a left side elevational view thereof;

FIG. 4 is a right side elevational view thereof;

FIG. 5 is a top plan view thereof;

FIG. 6 is a bottom plan view thereof;

FIG. 7 is a front left perspective view thereof; and,

FIG. 8 is a rear right perspective view thereof.

**1 Claim, 8 Drawing Sheets**

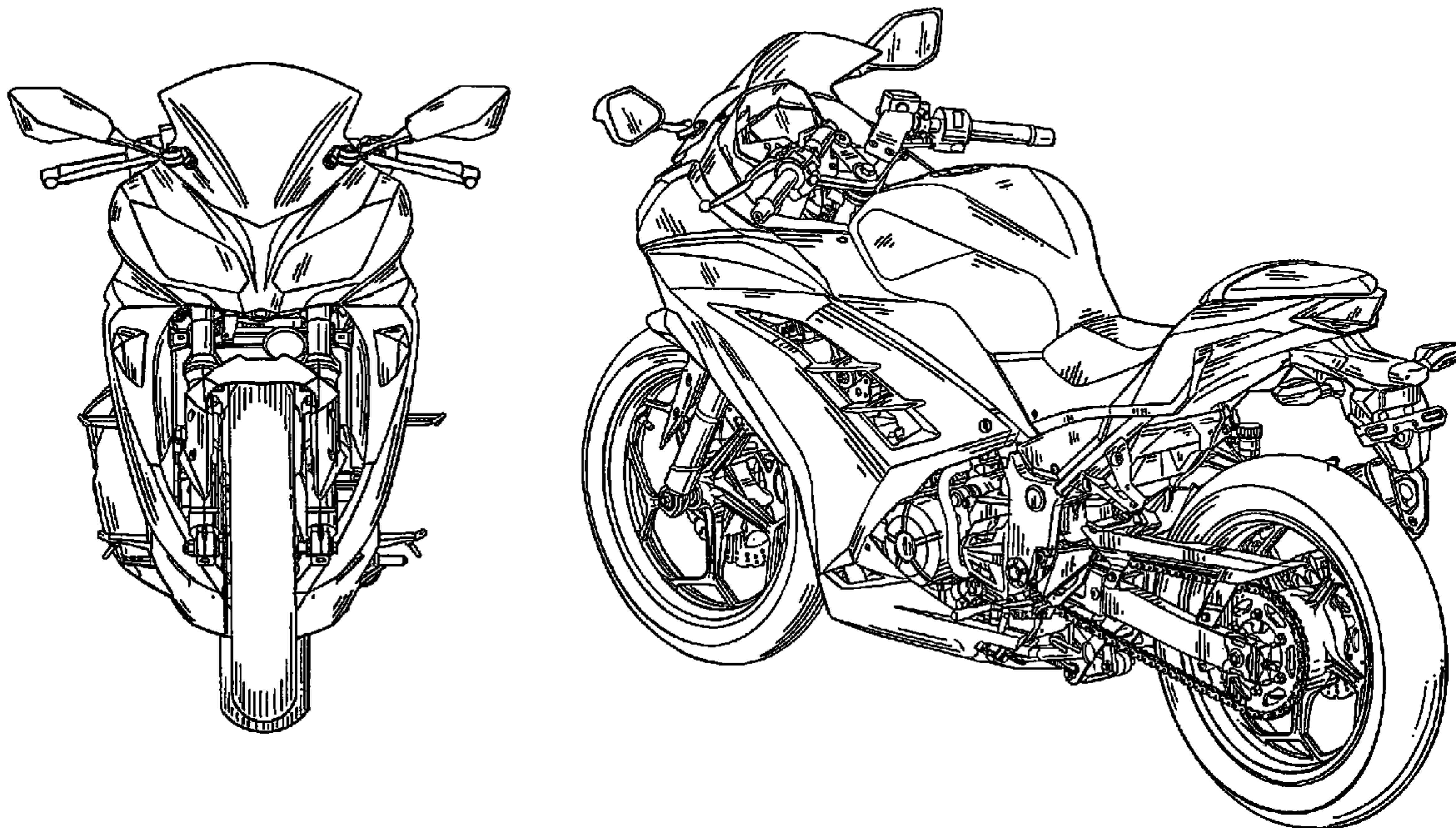

Fig. 1

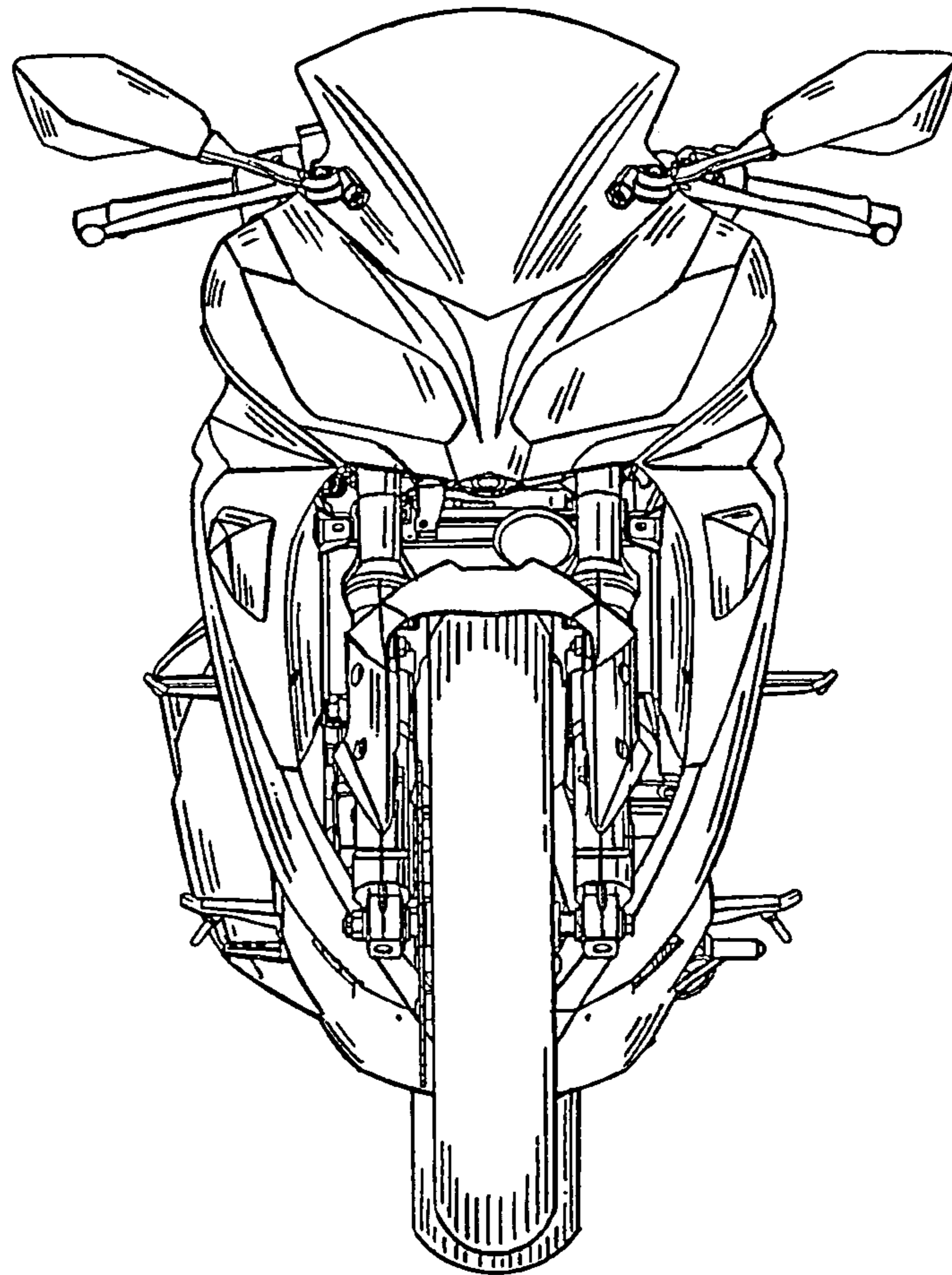
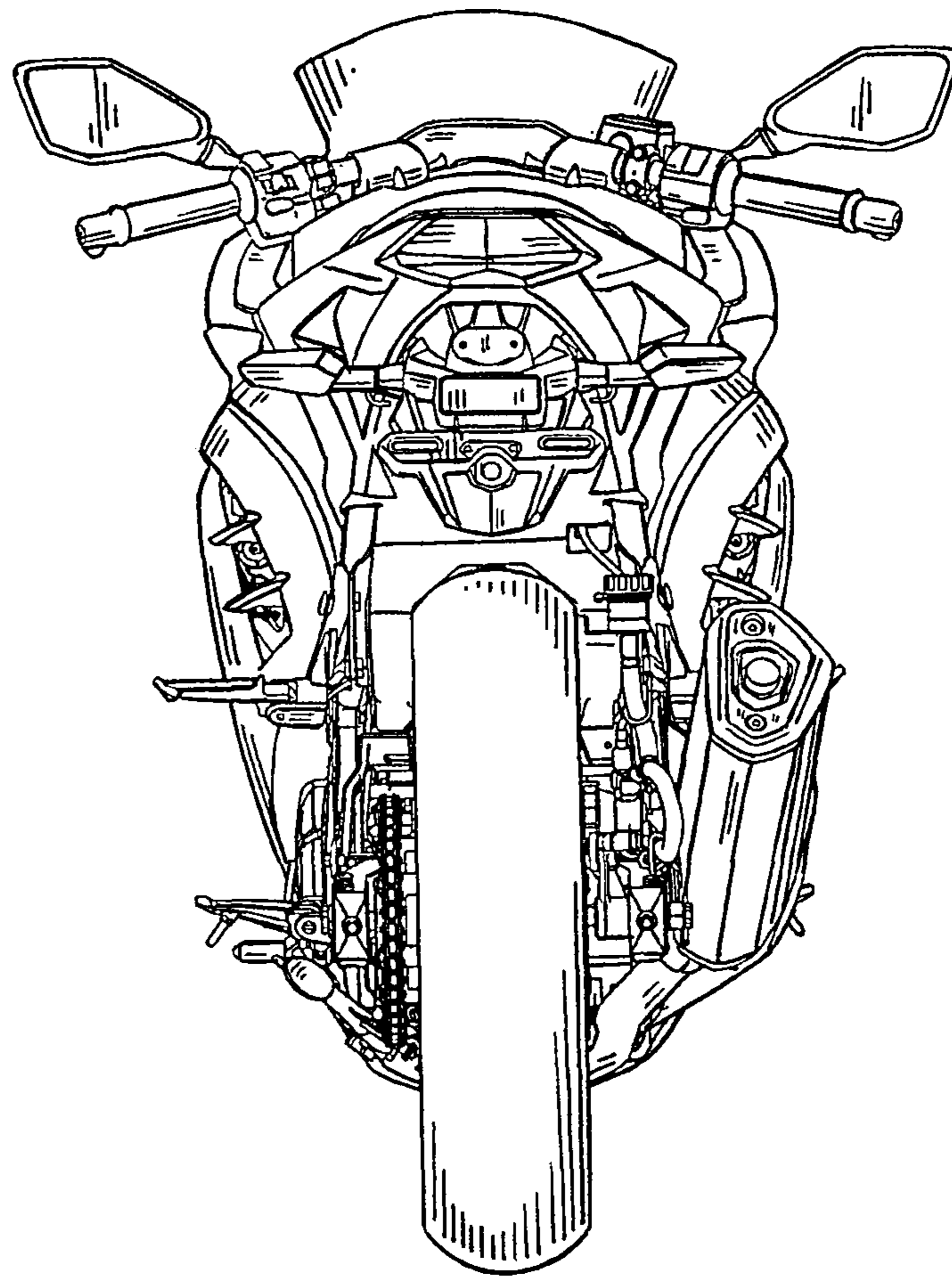

Fig. 2



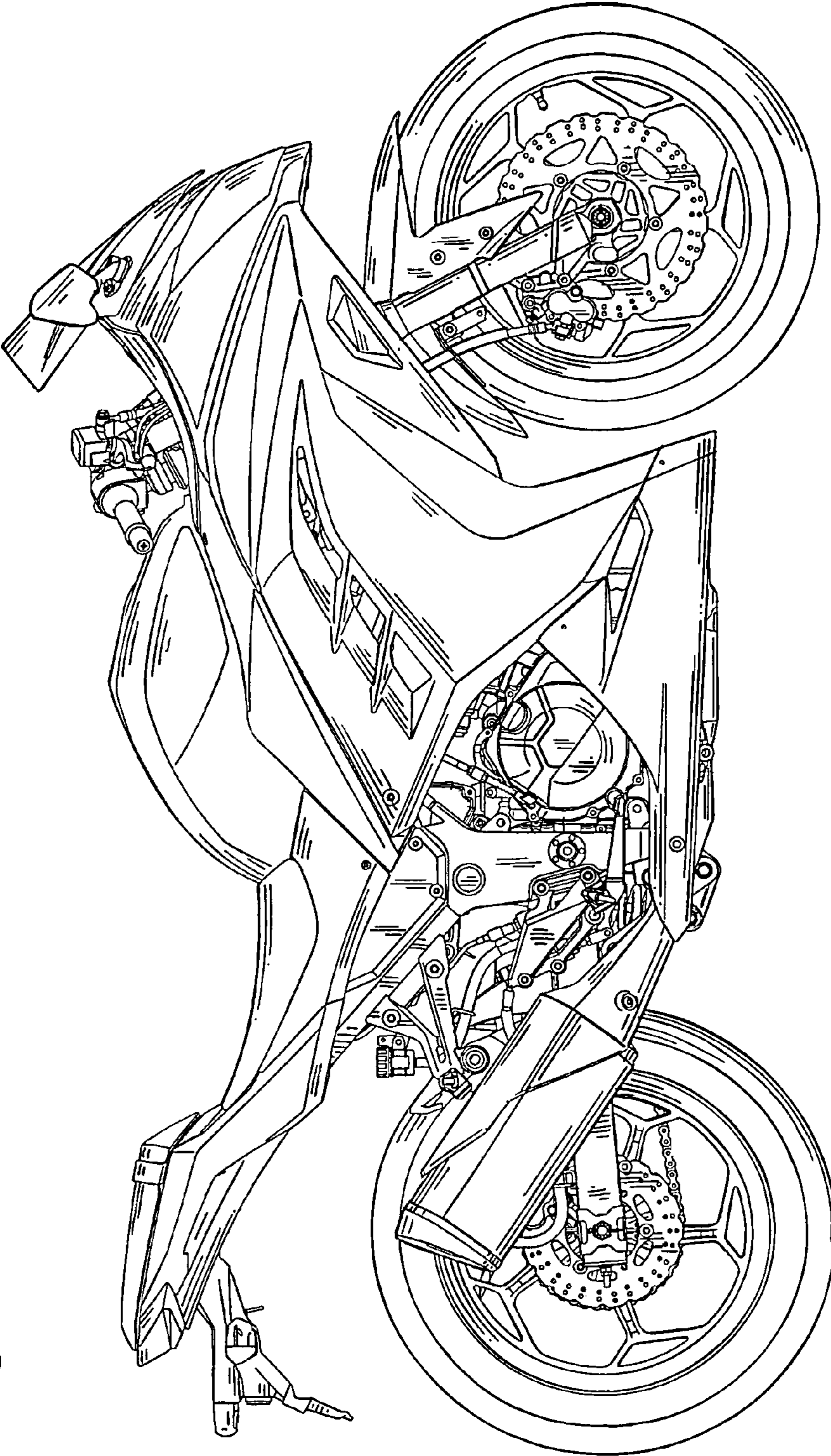

Fig. 3

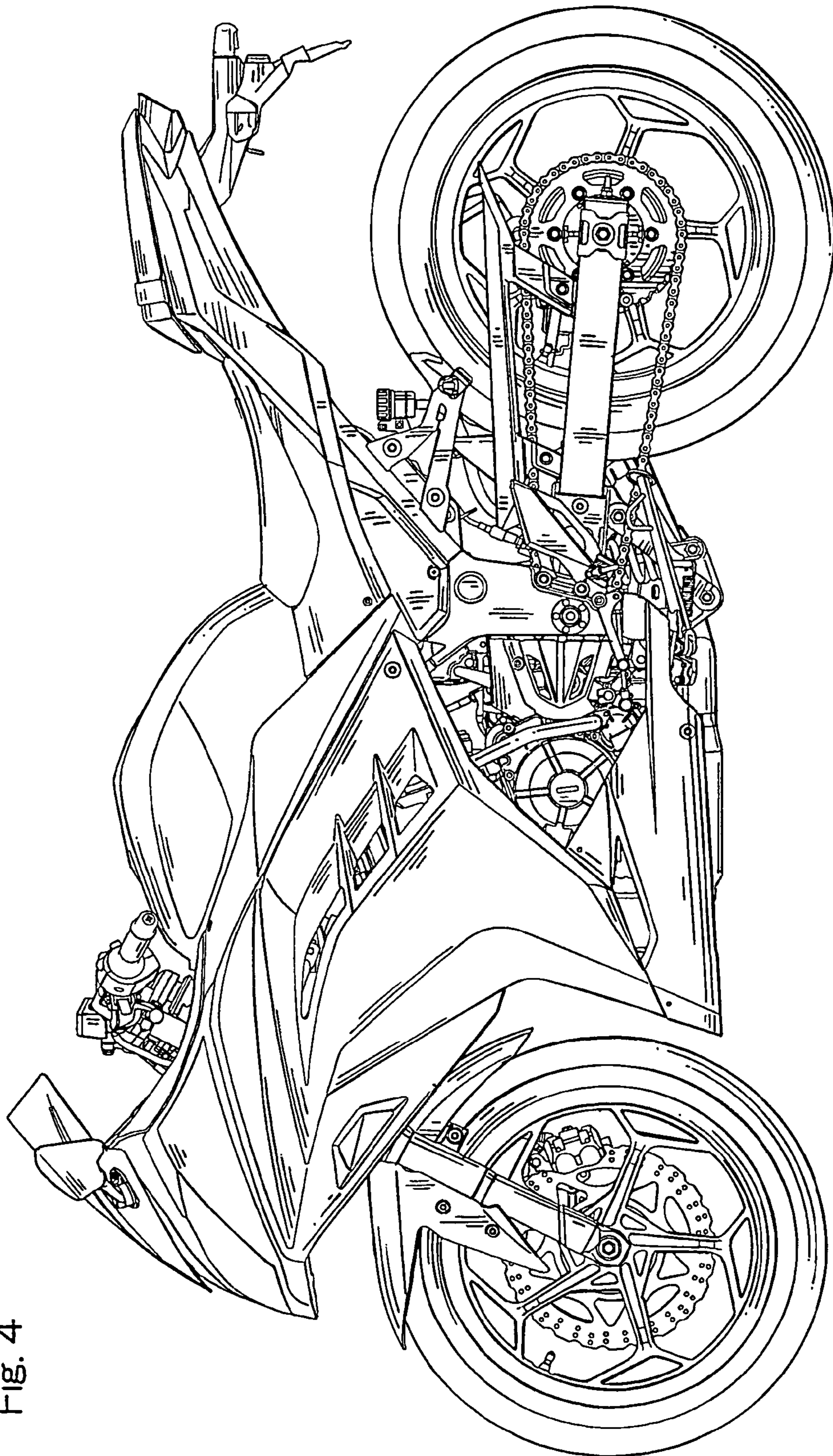

Fig. 4

Fig. 5

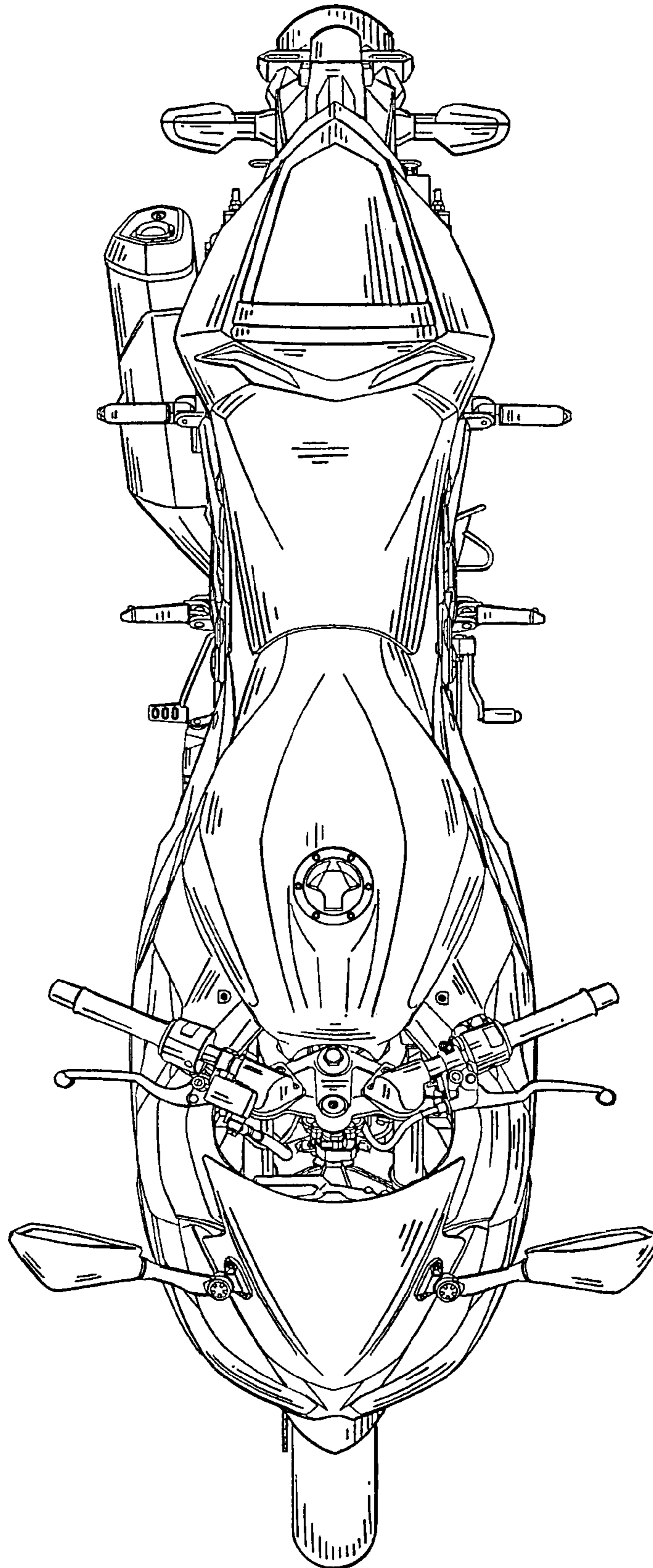
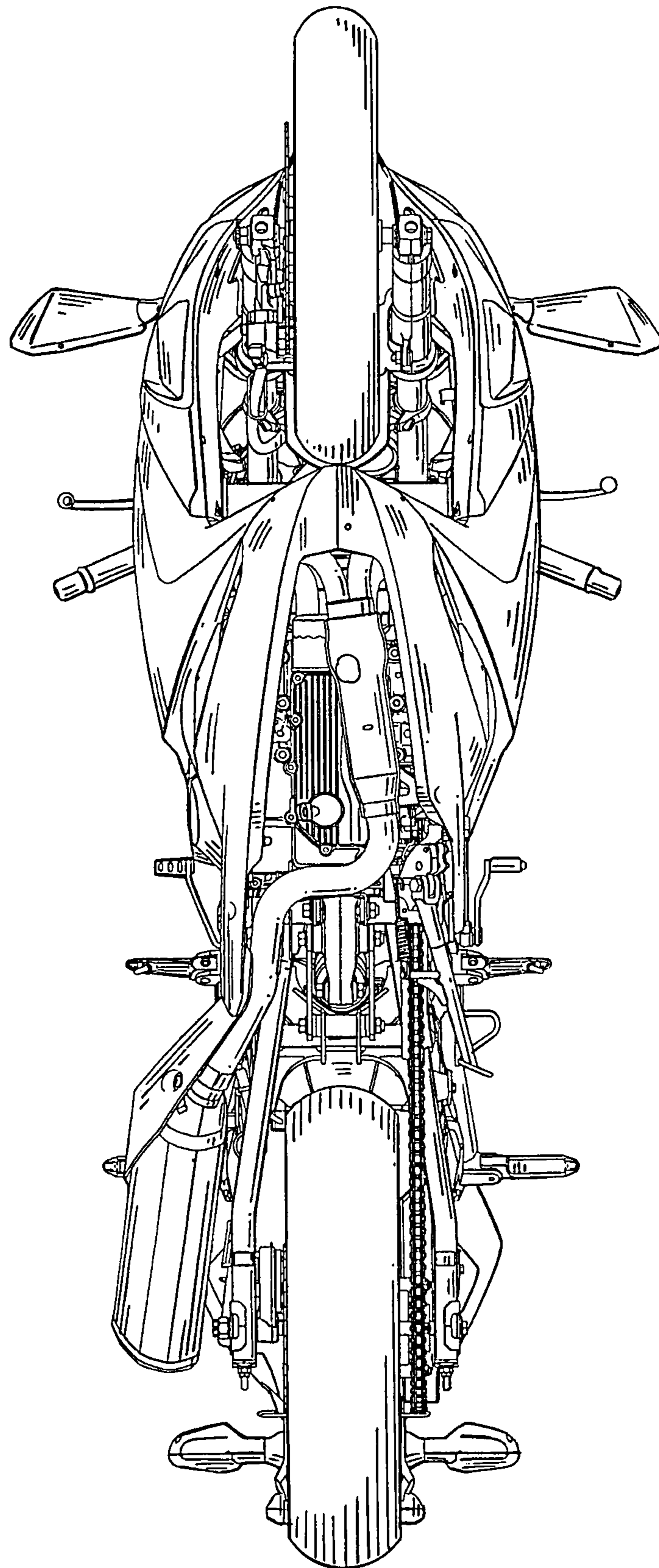

Fig. 6



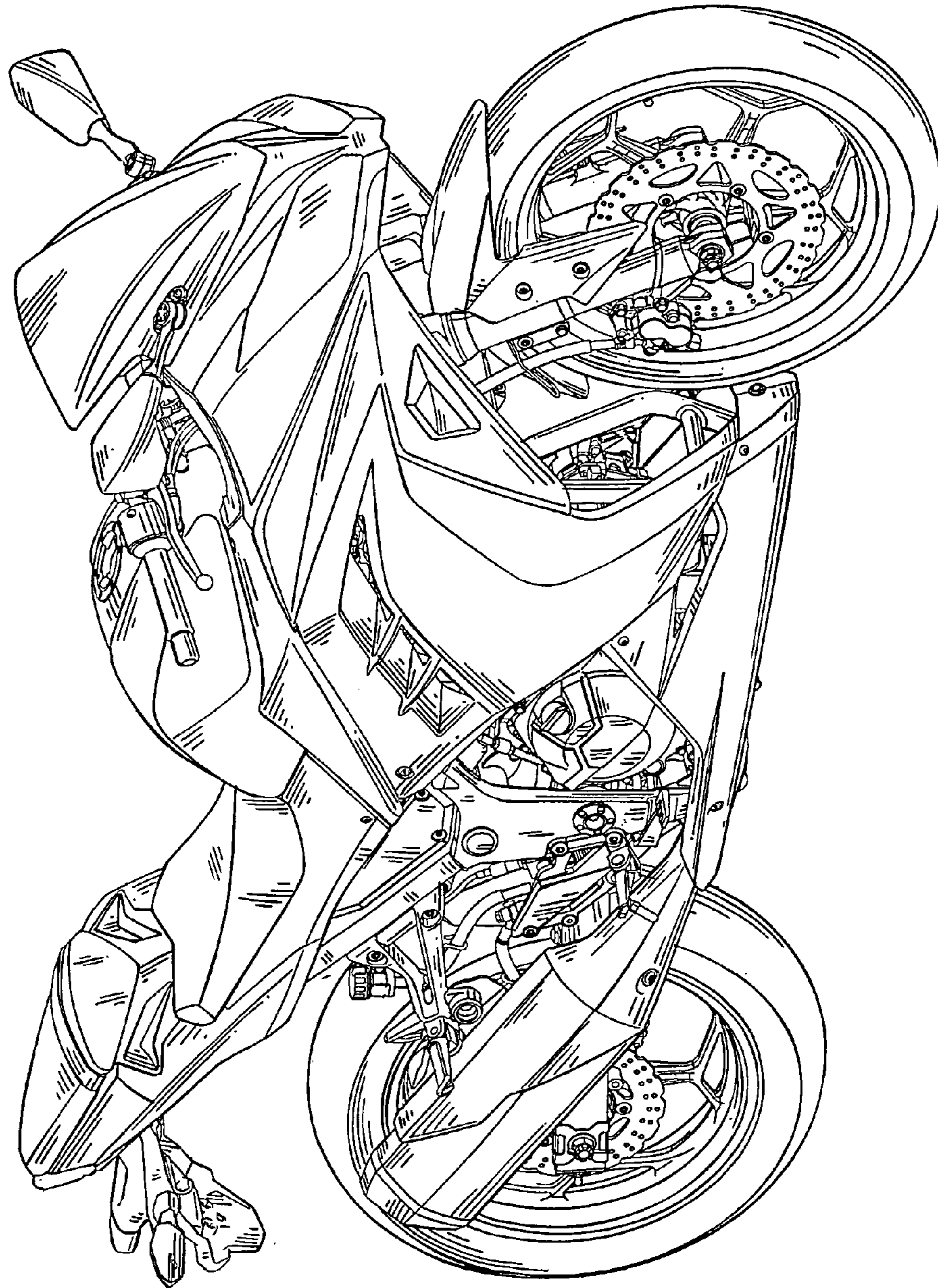

Fig. 7



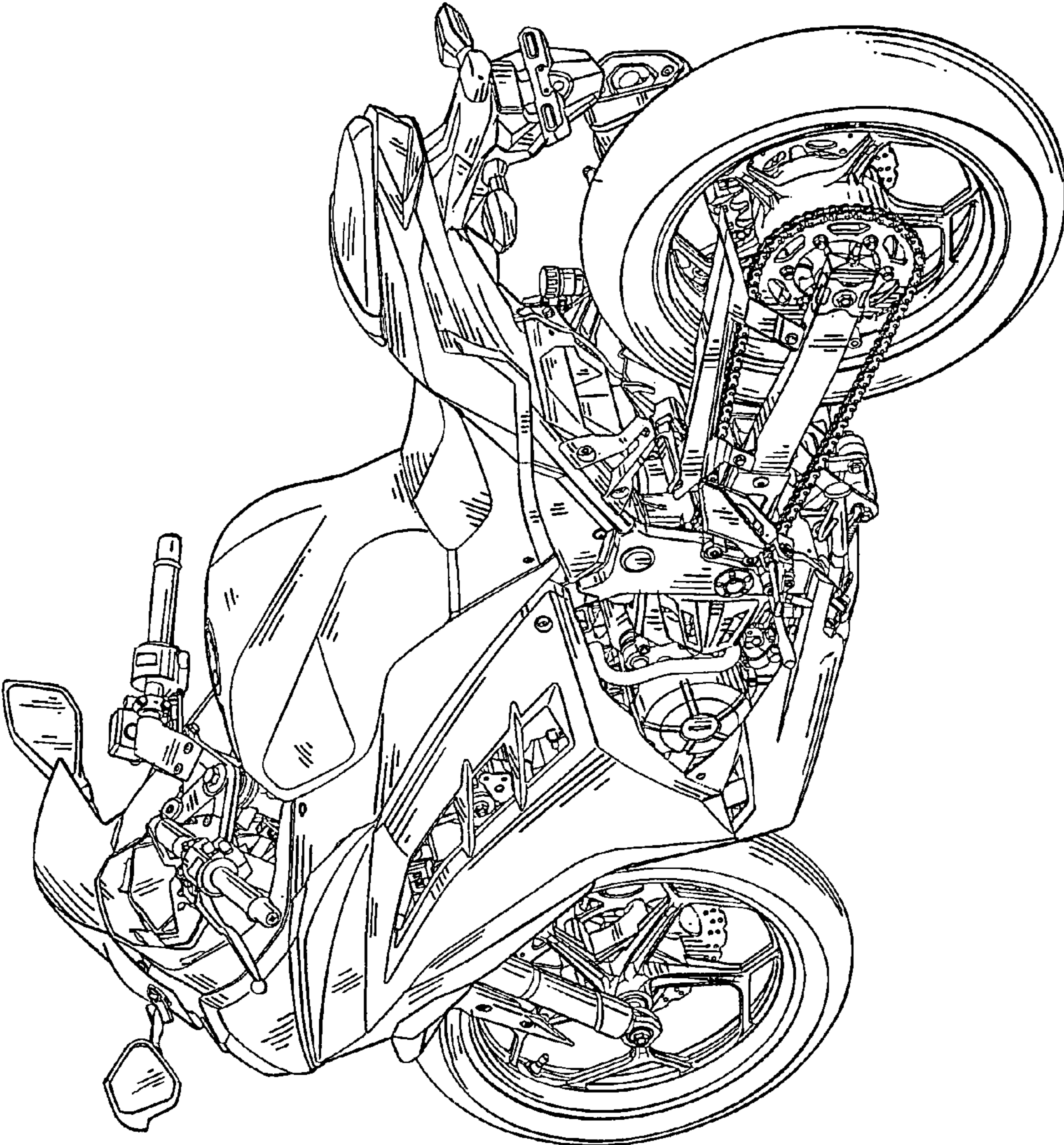

Fig. 8