



US00D688961S

(12) **United States Design Patent**
Haws

(10) **Patent No.:** **US D688,961 S**

(45) **Date of Patent:** **** Sep. 3, 2013**

(54) **MOTION SENSOR**

600/595, 485, 481, 483; D26/60-66, 51,
D26/72

(71) Applicant: **Coleman Cable, Inc.**, Waukegan, IL
(US)

See application file for complete search history.

(72) Inventor: **Matthew Haws**, Indianapolis, IN (US)

(56) **References Cited**

(73) Assignee: **Coleman Cable, Inc.**, Waukegan, IL
(US)

U.S. PATENT DOCUMENTS

(**) Term: **14 Years**

D438,133	S	2/2001	Leen	
D453,387	S	2/2002	Leen	
6,472,997	B2	10/2002	Leen	
6,781,129	B2	8/2004	Leen	
7,463,148	B2	12/2008	Leen	
2009/0102648	A1*	4/2009	Lung	340/541
2013/0038225	A1*	2/2013	Brian R. et al.	315/159

(21) Appl. No.: **29/449,038**

* cited by examiner

(22) Filed: **Mar. 14, 2013**

(51) **LOC (9) Cl.** **10-04**

Primary Examiner — Antoine D Davis

(52) **U.S. Cl.**
USPC **D10/70; D10/106.8; D26/65**

(74) *Attorney, Agent, or Firm* — Patzik, Frank & Samotny Ltd.

(58) **Field of Classification Search**
USPC D10/65, 70, 75, 78, 106.1-106.8;
D14/138 R, 138 AA, 138 AB, 138 AC, 138 AD,
D14/341-347, 507-510, 136, 167, 168, 496,
D14/498, 499, 500, 125-134, 239, 371, 374-377,
D14/440, 450, 448, 336, 342; 343/702;
345/87, 104, 133, 156, 168, 173, 901-905,
345/165; 348/180, 184, 315, 739, 836, 838,
348/325; 364/444, 499; 701/408-418, 431,
701/432, 537; 312/7.2; 341/12; 720/605,
720/669, 600, 655; 369/99, 197; 455/344,
455/347, 575.1; 250/221, 338.3, 340, 239,
250/342, 341, DIG. 1, 353; 307/116, 117;
340/521, 527, 541, 567, 540, 568.2, 539.23,
340/635, 687; 315/159; 324/72.5, 556, 133,
324/149, 503, 543, 555, 66, 72, 754, 115,
324/141, 522; 73/615, 624, 627, 644, 514.33,
73/514.34, 510, 513, 527, 530; 356/3.01-5.15;
235/105; 377/5, 24.2, 26; 702/155, 160,
702/176, 78, 79, 82, 91-95, 104, 116, 141,
702/150, 151, 154, 127, 131, 182, 183, 189;
600/437, 443, 453, 459, 465, 479, 500, 502,

(57) **CLAIM**
The ornamental design for a motion sensor, as shown and described.

DESCRIPTION

FIG. 1 is a front perspective view of the motion sensor of the present invention;
FIG. 2 is a front elevation view of the motion sensor of the present invention;
FIG. 3 is a rear elevation view of the motion sensor of the present invention;
FIG. 4 is a left side elevation view of the motion sensor of the present invention;
FIG. 5 is a right side elevation view of the motion sensor of the present invention;
FIG. 6 is a top plan view of the motion sensor of the present invention; and,
FIG. 7 is a bottom plan view of the motion sensor of the present invention.
The portions shown in broken lines form no part of the claimed design.

1 Claim, 4 Drawing Sheets

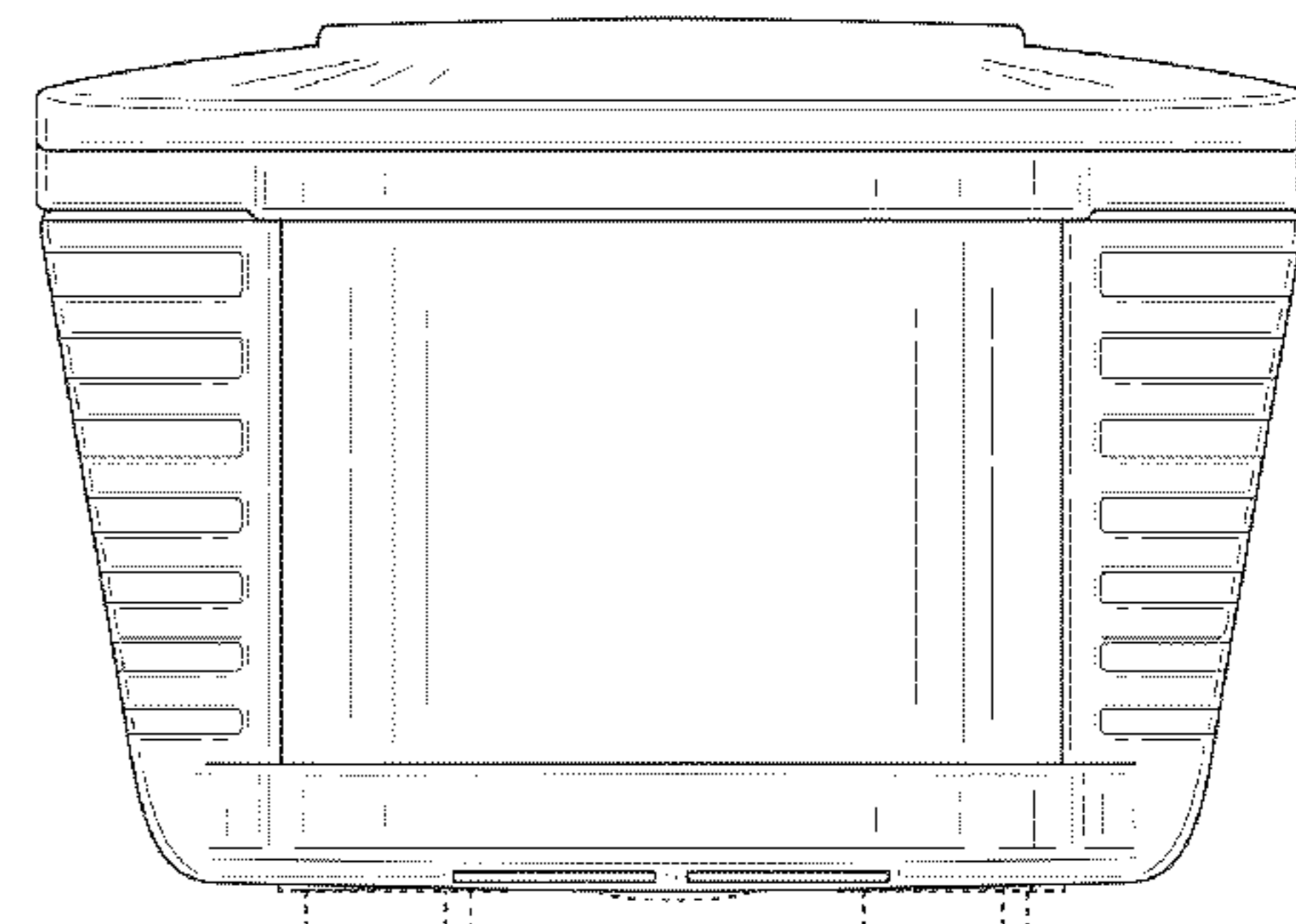
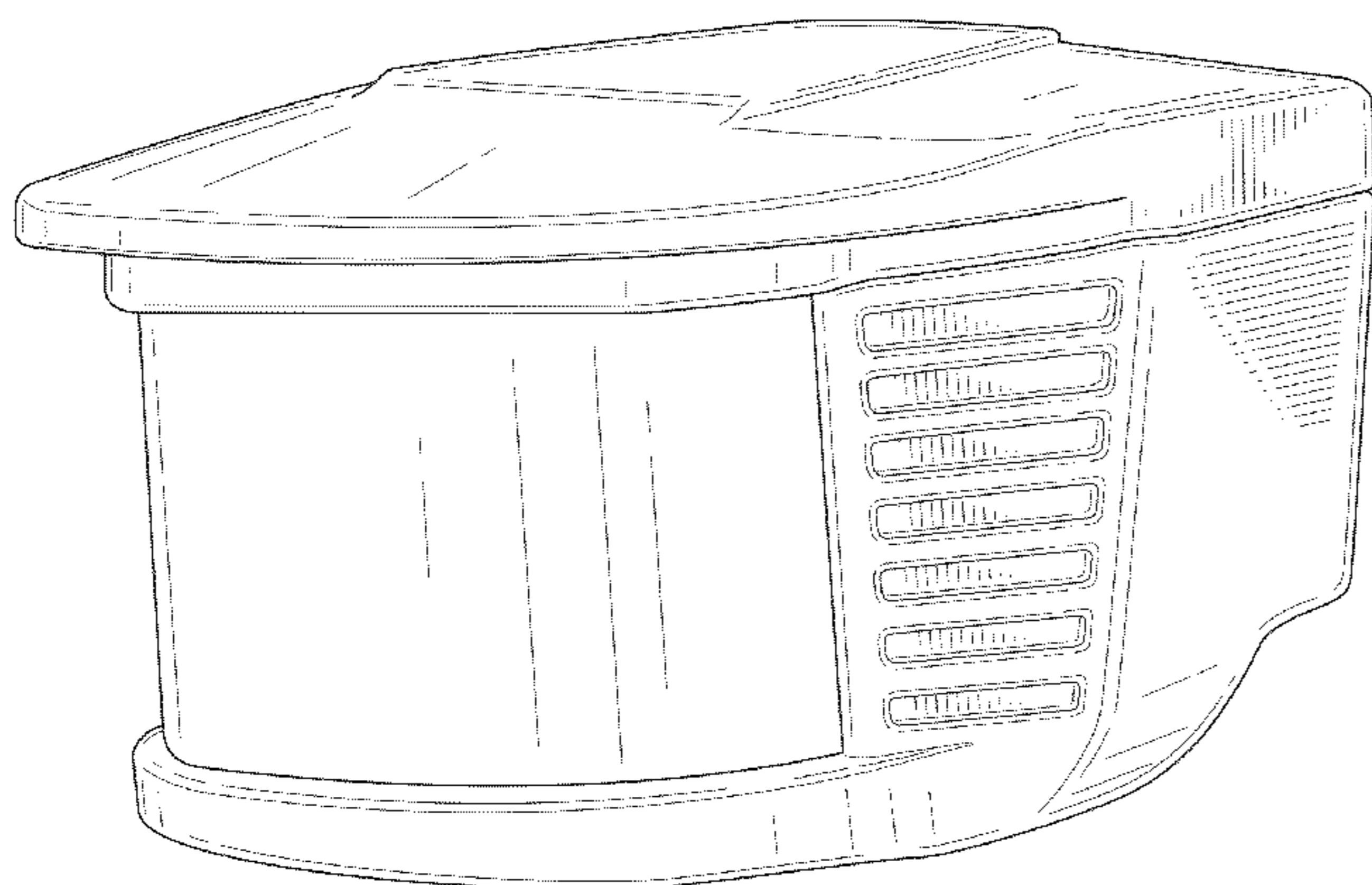

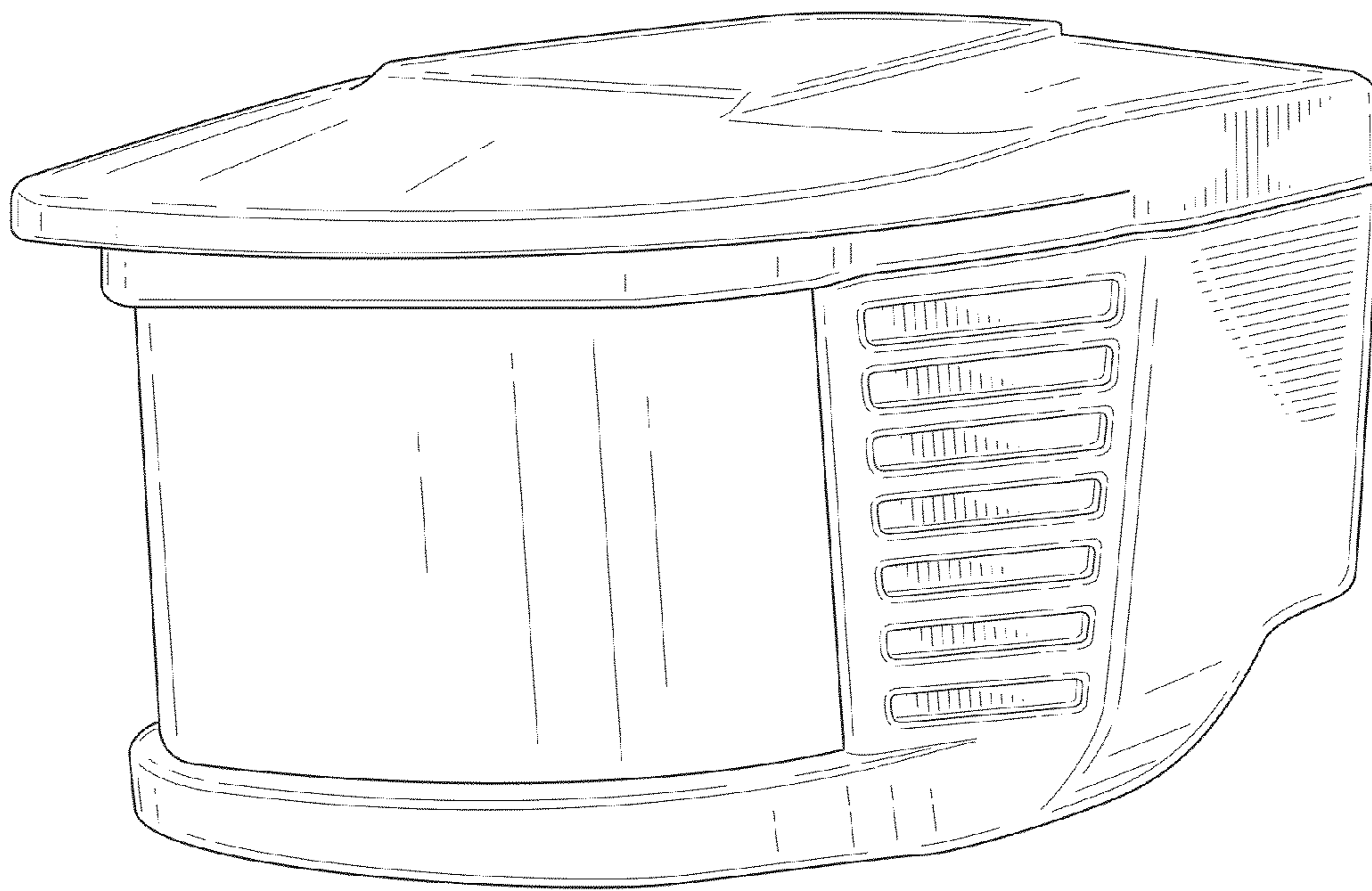

FIG. 1

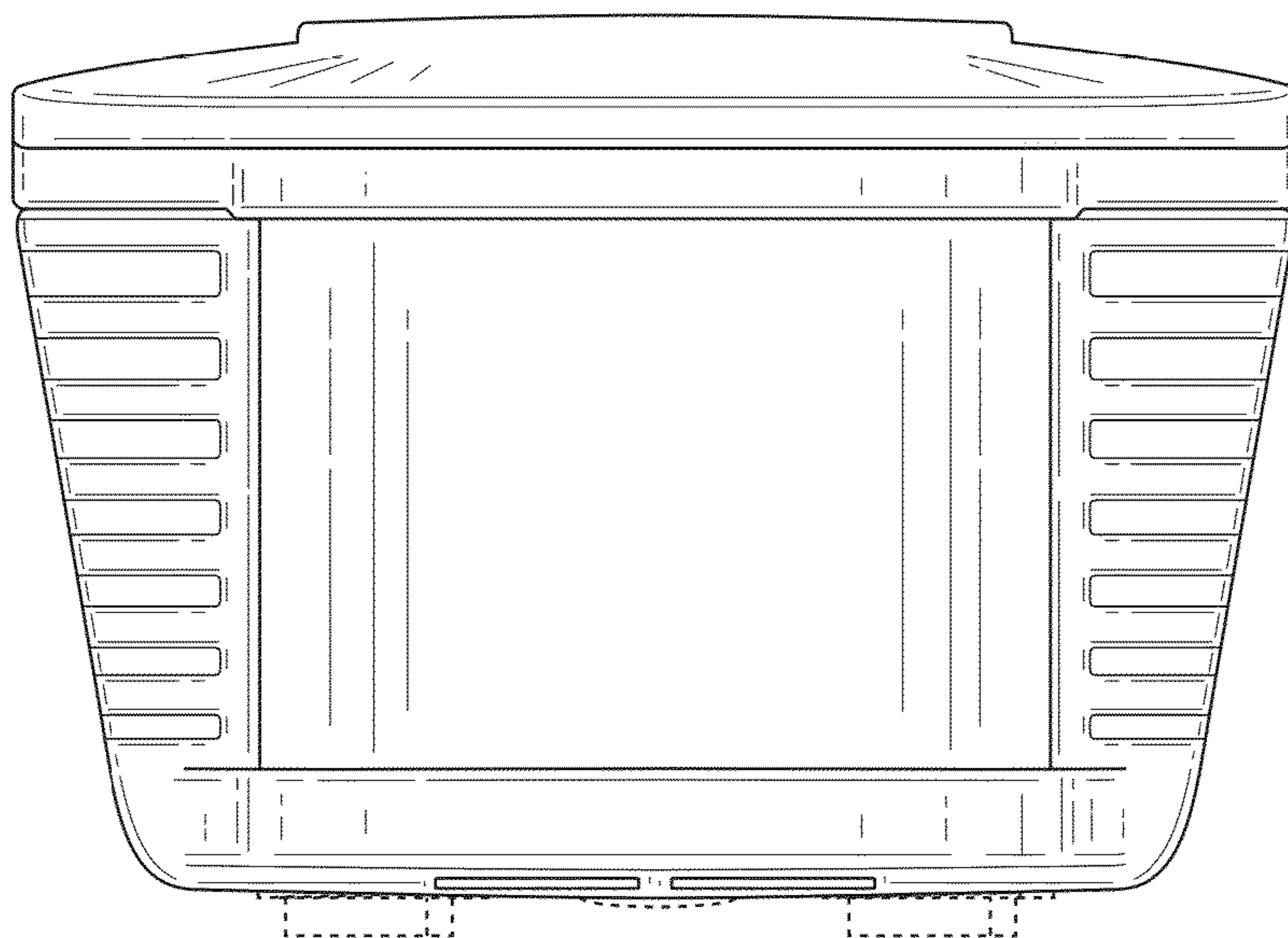

FIG. 2

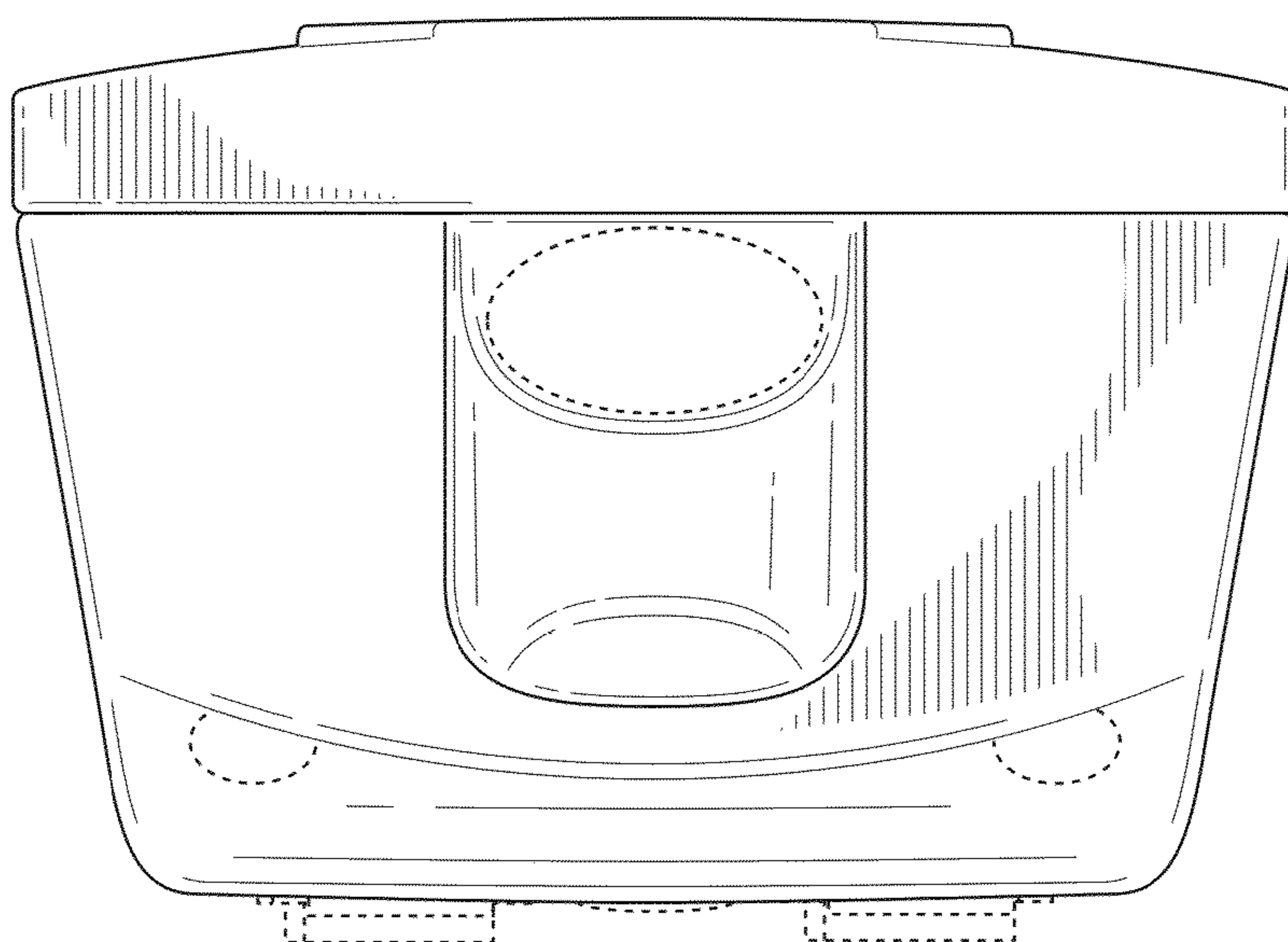

FIG. 3

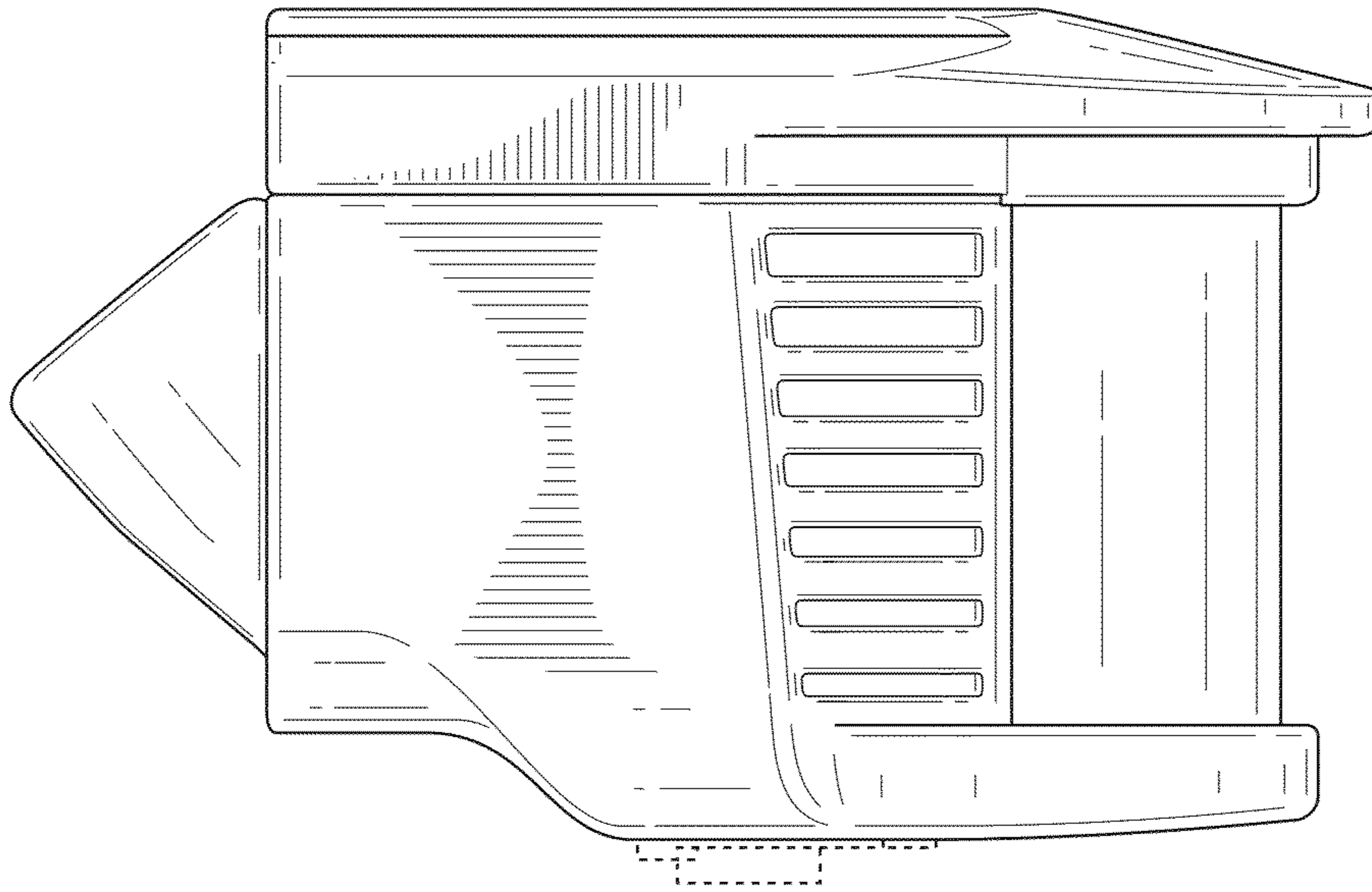

FIG. 4

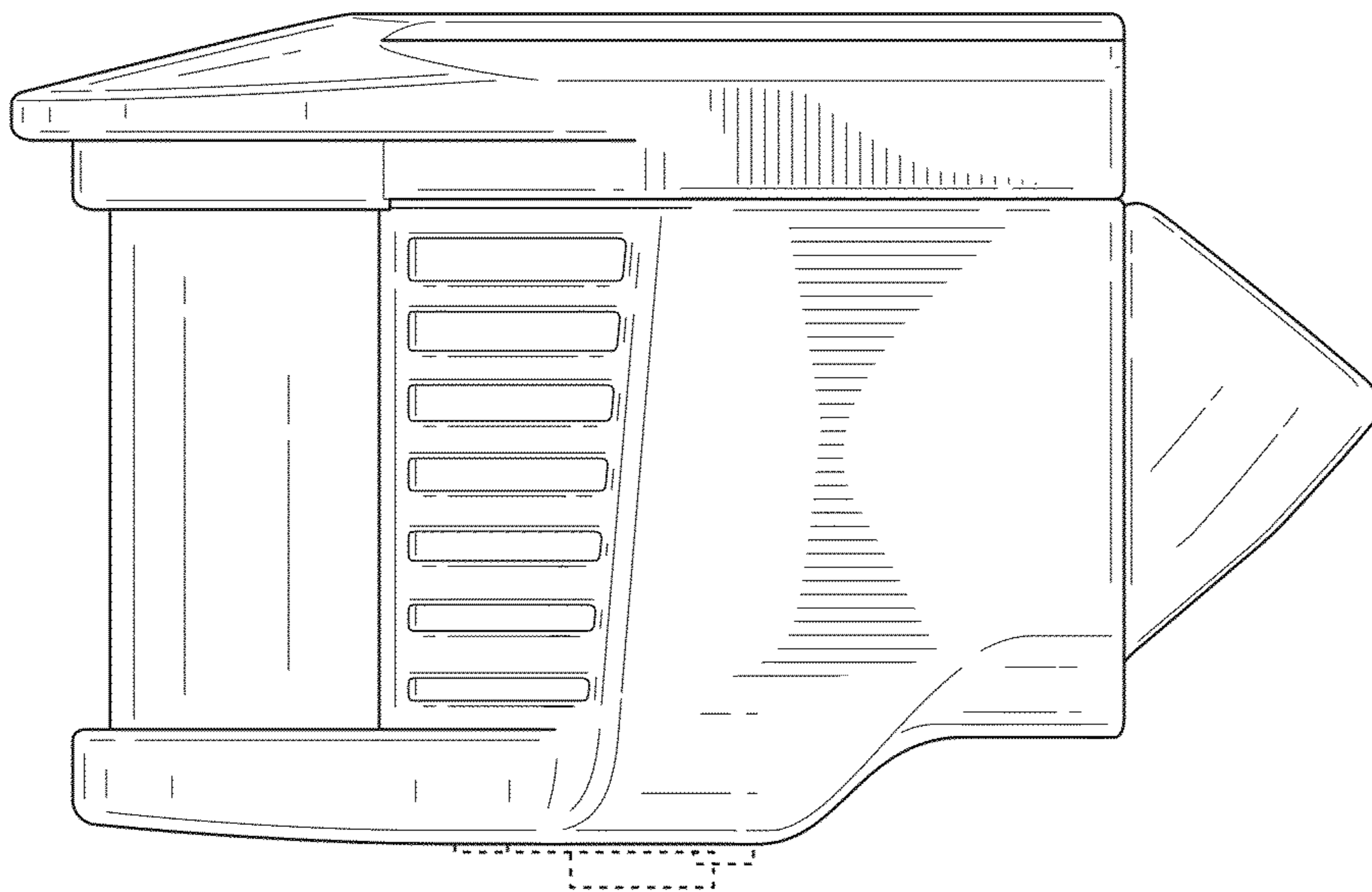

FIG. 5

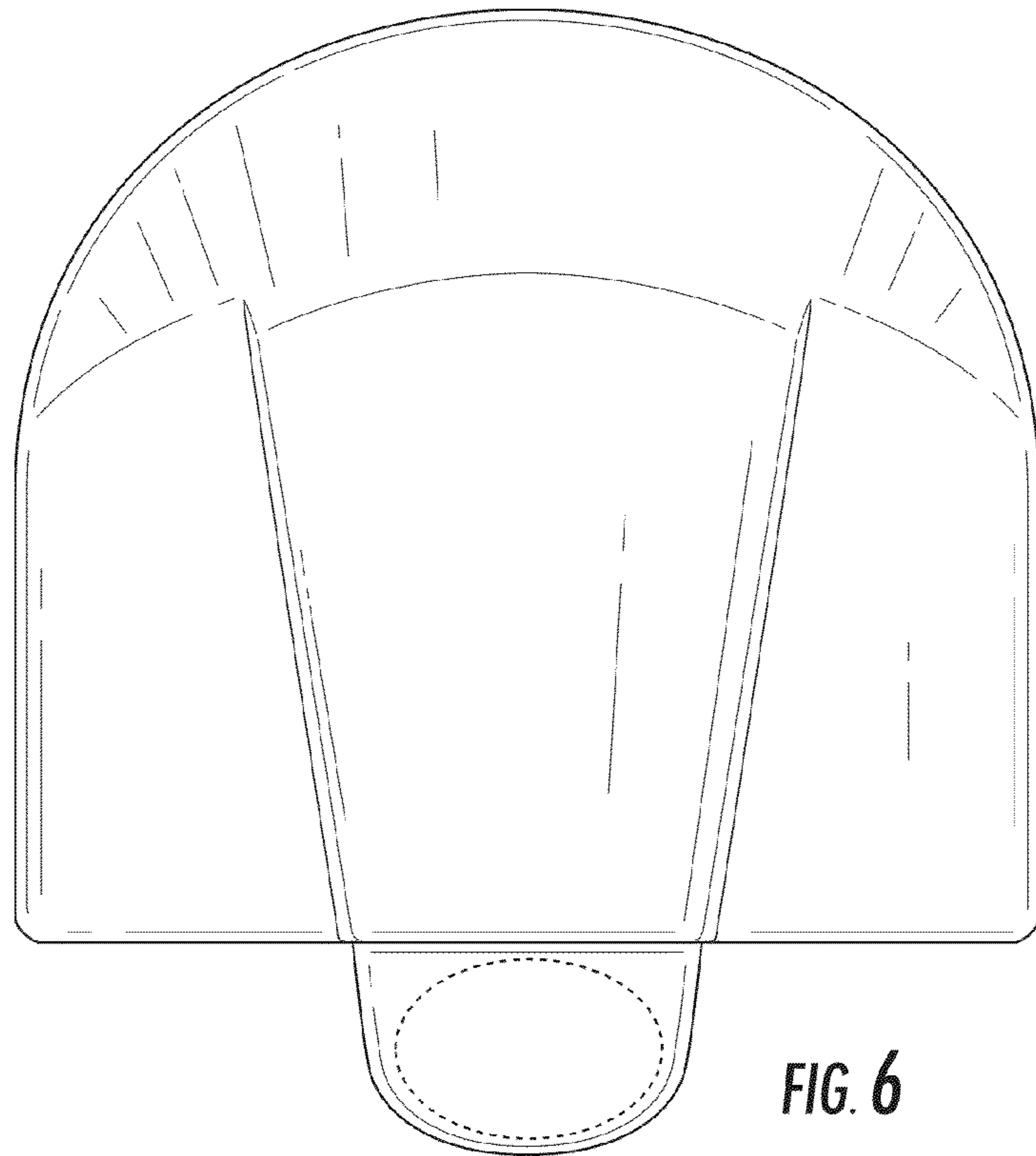

FIG. 6

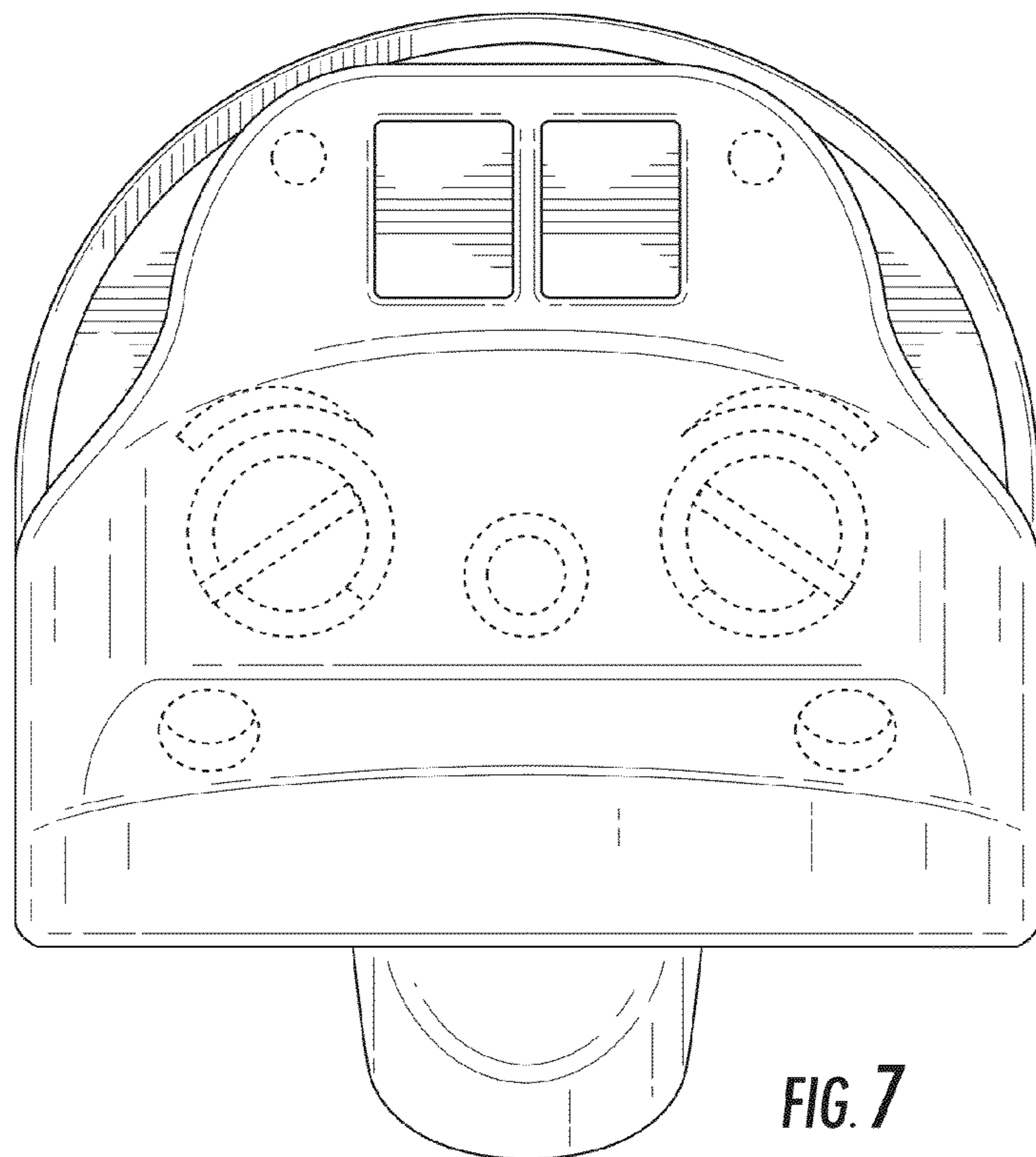

FIG. 7