



US00D688799S

(12) **United States Design Patent**
Steinbrecher

(10) **Patent No.:** **US D688,799 S**

(45) **Date of Patent:** **** Aug. 27, 2013**

(54) **DETECTION BODY FOR A DENTAL PROSTHETIC**

(75) Inventor: **Tillmann Steinbrecher**, Darmstadt (DE)

(73) Assignee: **exocad GmbH**, Darmstadt (DE)

(**) Term: **14 Years**

(21) Appl. No.: **29/409,359**

(22) Filed: **Dec. 22, 2011**

(51) **LOC (9) Cl.** **24-02**

(52) **U.S. Cl.**
USPC **D24/155**

(58) **Field of Classification Search**
USPC D24/152, 155–156, 176–177, 180–182;
433/72, 75, 172–173, 181–182, 220
See application file for complete search history.

(56) **References Cited**

U.S. PATENT DOCUMENTS

5,401,170	A *	3/1995	Nonomura	433/173
6,688,887	B2 *	2/2004	Morgan	433/173
8,275,184	B2 *	9/2012	Schneider et al.	382/128

(Continued)

Primary Examiner — Wan Laymon

(74) *Attorney, Agent, or Firm* — Neifeld IP Law, PC

(57) **CLAIM**

The ornamental design for a detection body for a dental prosthetic, as shown and described.

DESCRIPTION

FIG. 1 is a perspective view of a detection body for a dental prosthetic showing my design;
FIG. 2 is a right side view thereof;
FIG. 3 is a front view thereof;
FIG. 4 is a left side view thereof;
FIG. 5 is a back side view thereof;

FIG. 6 is a top view thereof;
FIG. 7 is a bottom view thereof;
FIG. 8 is a perspective view of a second detection body for a dental prosthetic showing my design;
FIG. 9 is a right side view thereof;
FIG. 10 is a front side view thereof;
FIG. 11 is a left side view thereof;
FIG. 12 is a back side view thereof;
FIG. 13 is a top view thereof; and,
FIG. 14 is a bottom side view thereof.

The scan-adaptor is a location and orientation identifier for use in identifying location and orientation within a scanning imaging system. In particular, the scan-adaptor can be fixed to an implant for scanning the position and orientation of the implant. After scanning the scan-adaptor and its environment, such as the dentition of a person, corresponding prosthetics can be manufactured and fixed to the implant in the same manner or similar manner as the scan-adaptor.

The scan adaptor according to the present design comprises a spherical head having two missing spherical segments so that the spherical head comprises two circular flat surface areas, one at the top and one at the front. However, there is an optional bore extending from the circular flat area at the top through the body. The head is connected to a first cylindrical middle part at the bottom side of the head. The first cylindrical middle part is connected to a second cylindrical middle part on the bottom side of the first cylindrical middle part. The second cylindrical middle part is connected to a third cylindrical part on the bottom side of the second cylindrical middle part. The three cylindrical parts are arranged co-axial to each other, wherein the common longitudinal axis of the three cylindrical parts extends through the center of the spherical head and through the center of the circular flat area at the top of the head. At the bottom of the body, there is an optional bottom part comprising a truncated cone section on the bottom side of the third cylindrical part and a fourth cylindrical part having a rounded bottom edge at the bottom of the body. Broken lines in the drawings show environment and are not part of the claimed design.

1 Claim, 14 Drawing Sheets

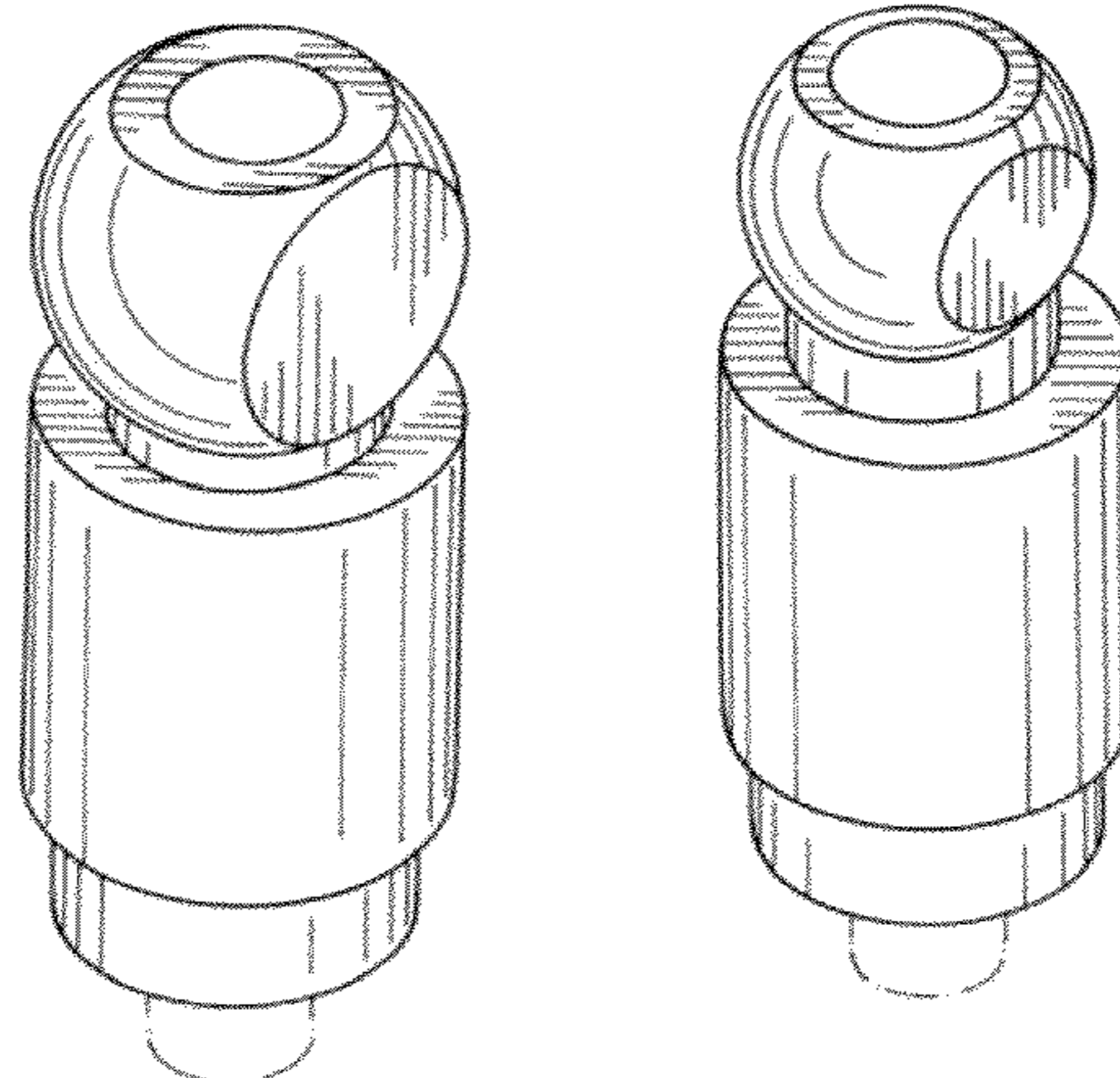

US D688,799 S

Page 2

(56)

References Cited

2012/0135371 A1* 5/2012 Jahn 433/72
2012/0141951 A1* 6/2012 Bellanca et al. 433/72

U.S. PATENT DOCUMENTS

8,303,303 B2* 11/2012 Brajnovic 433/75 * cited by examiner

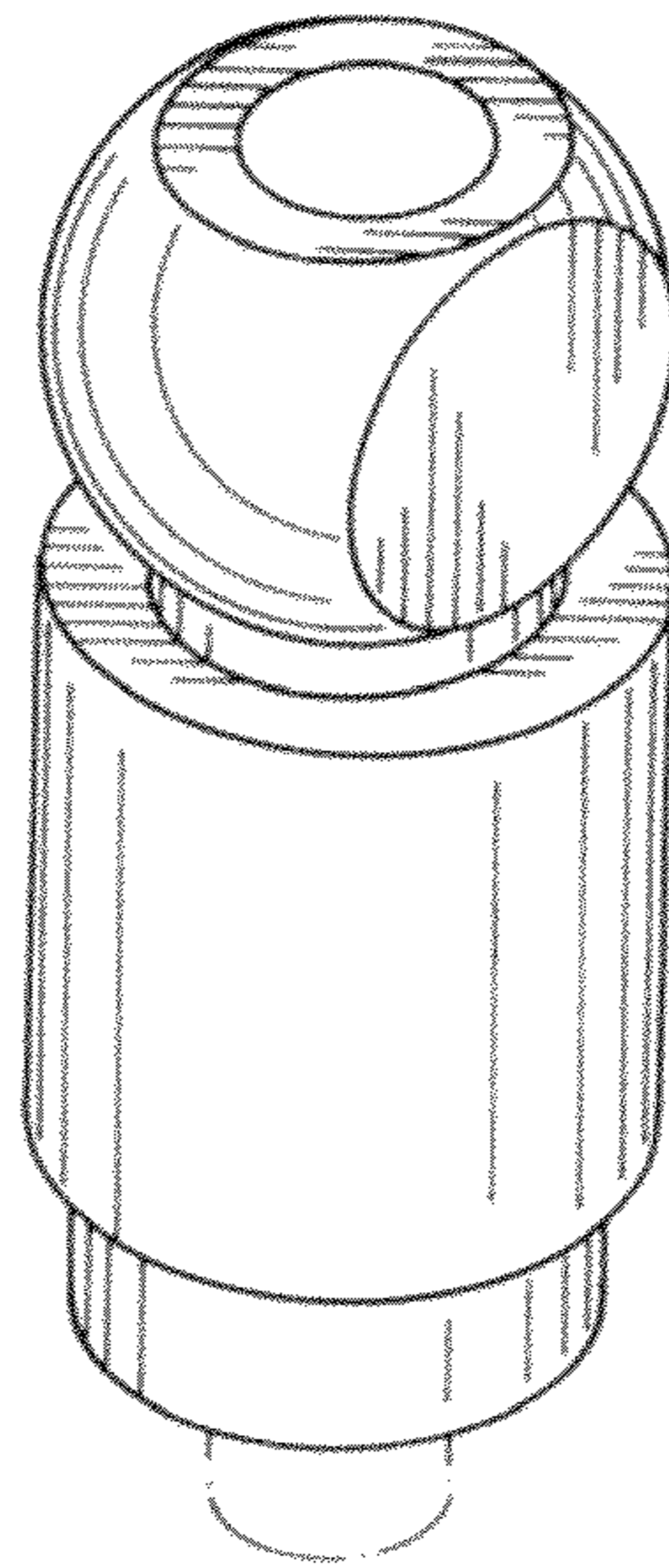

Fig. 1

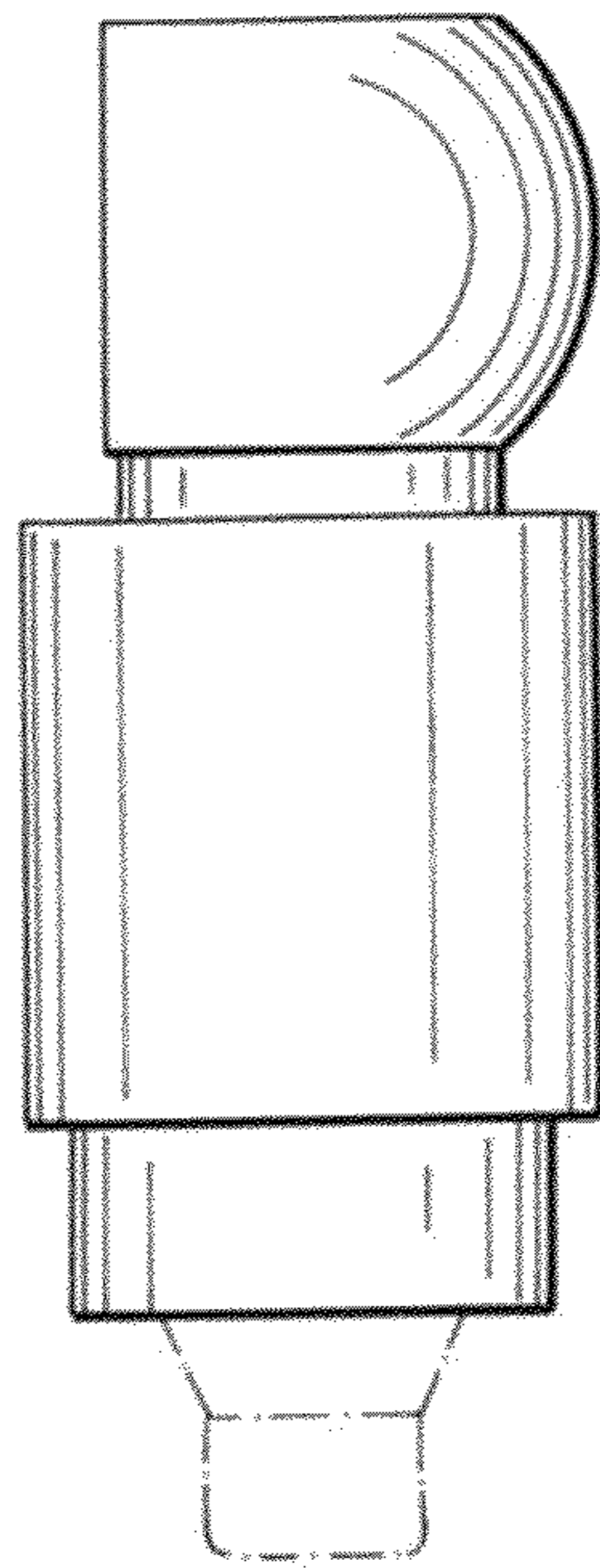

Fig. 2

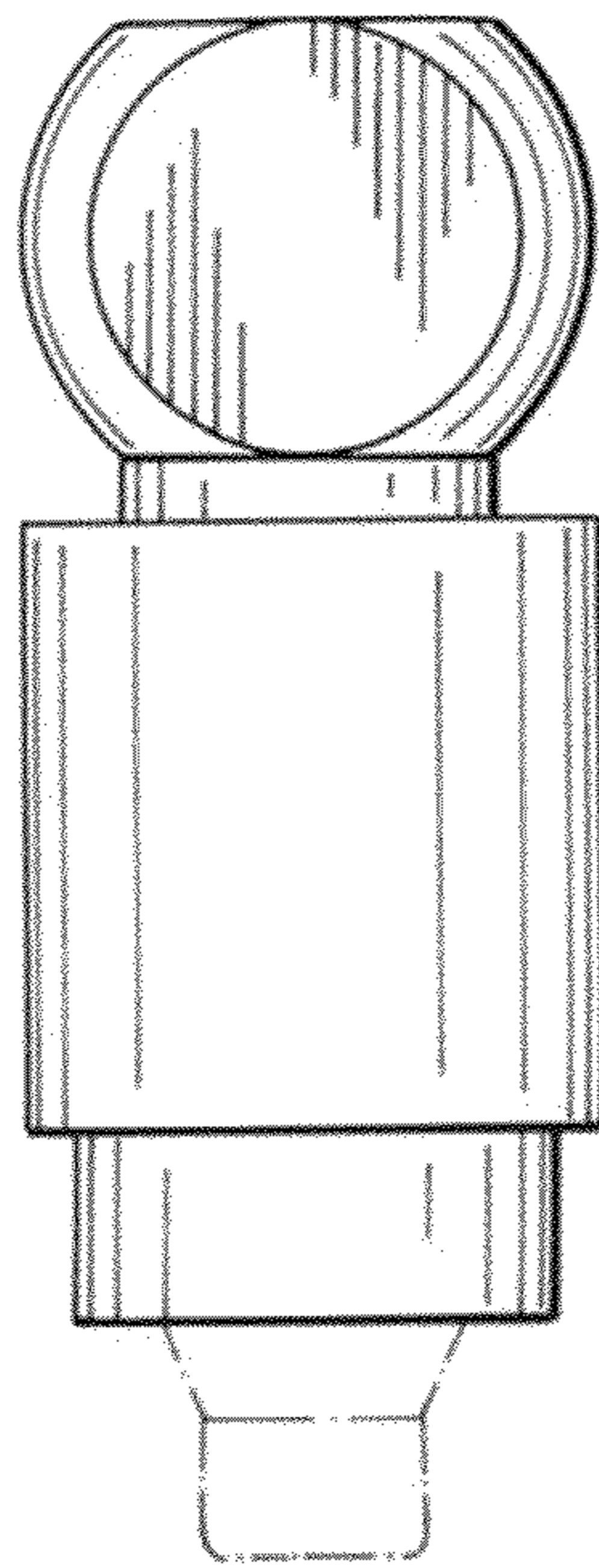

Fig. 3

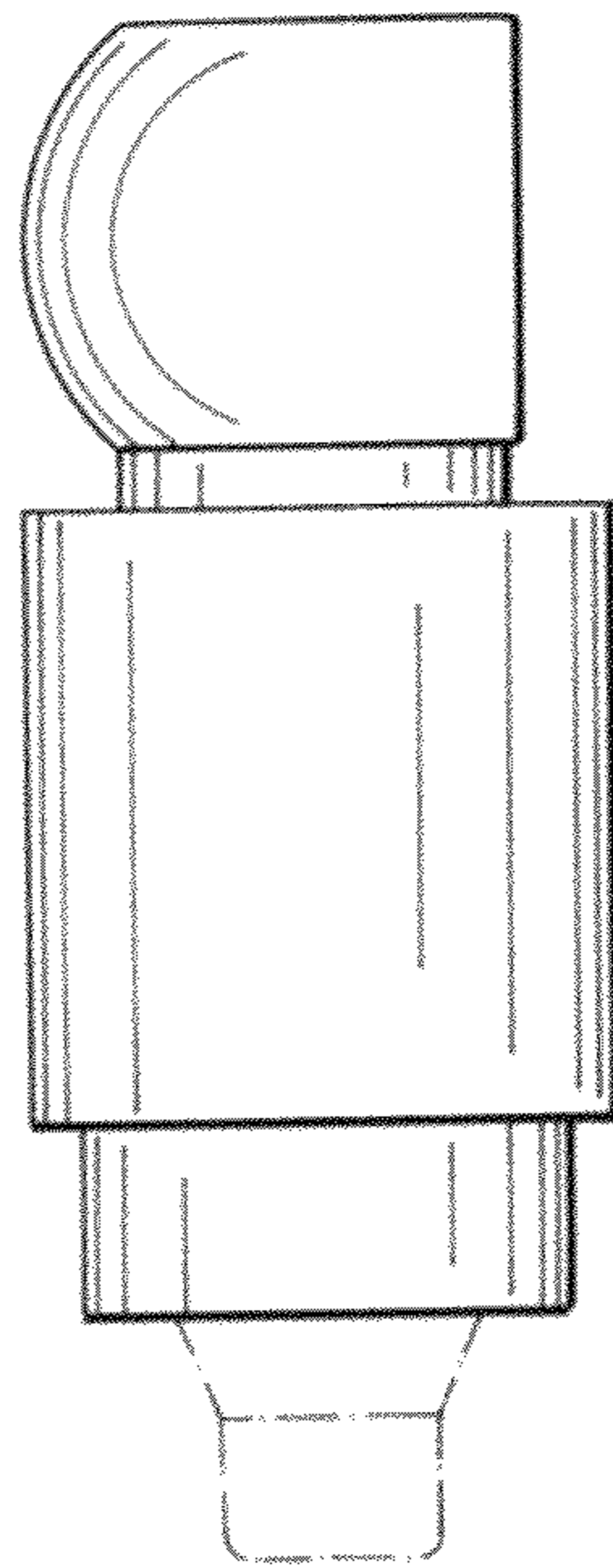

Fig. 4

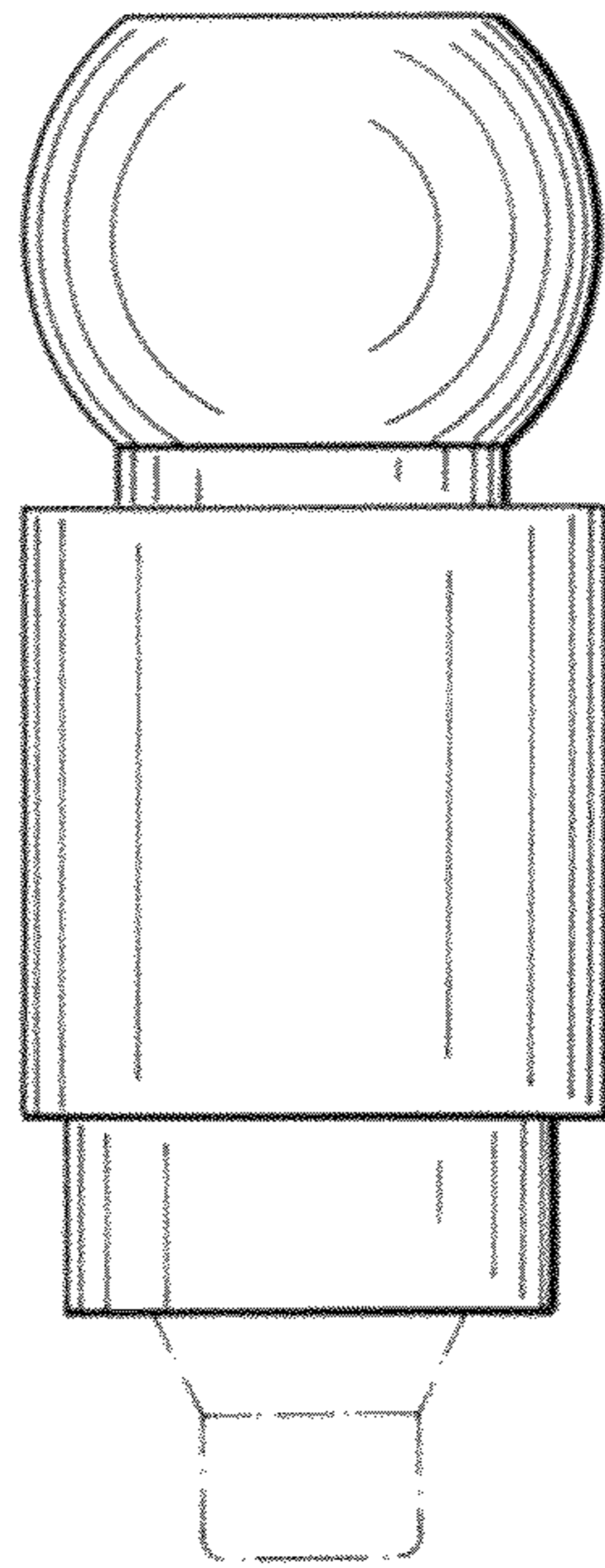

Fig. 5

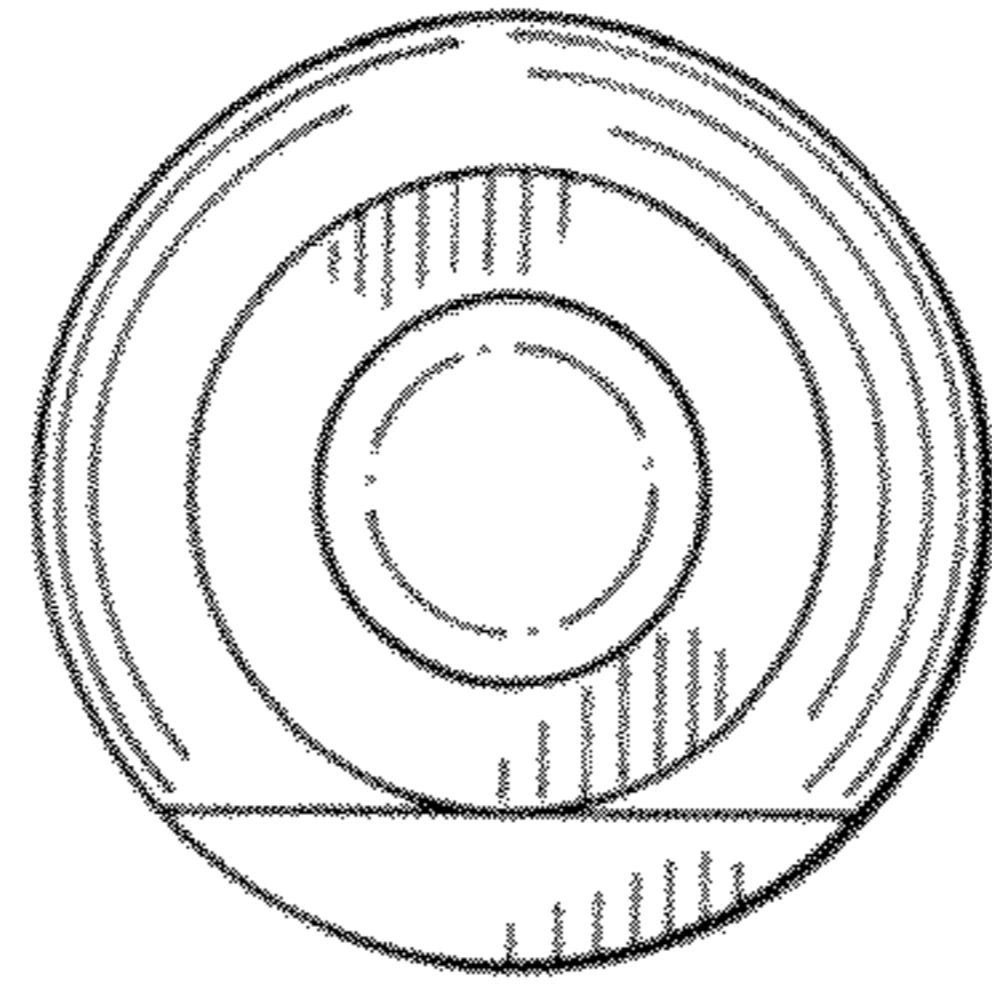

Fig. 6

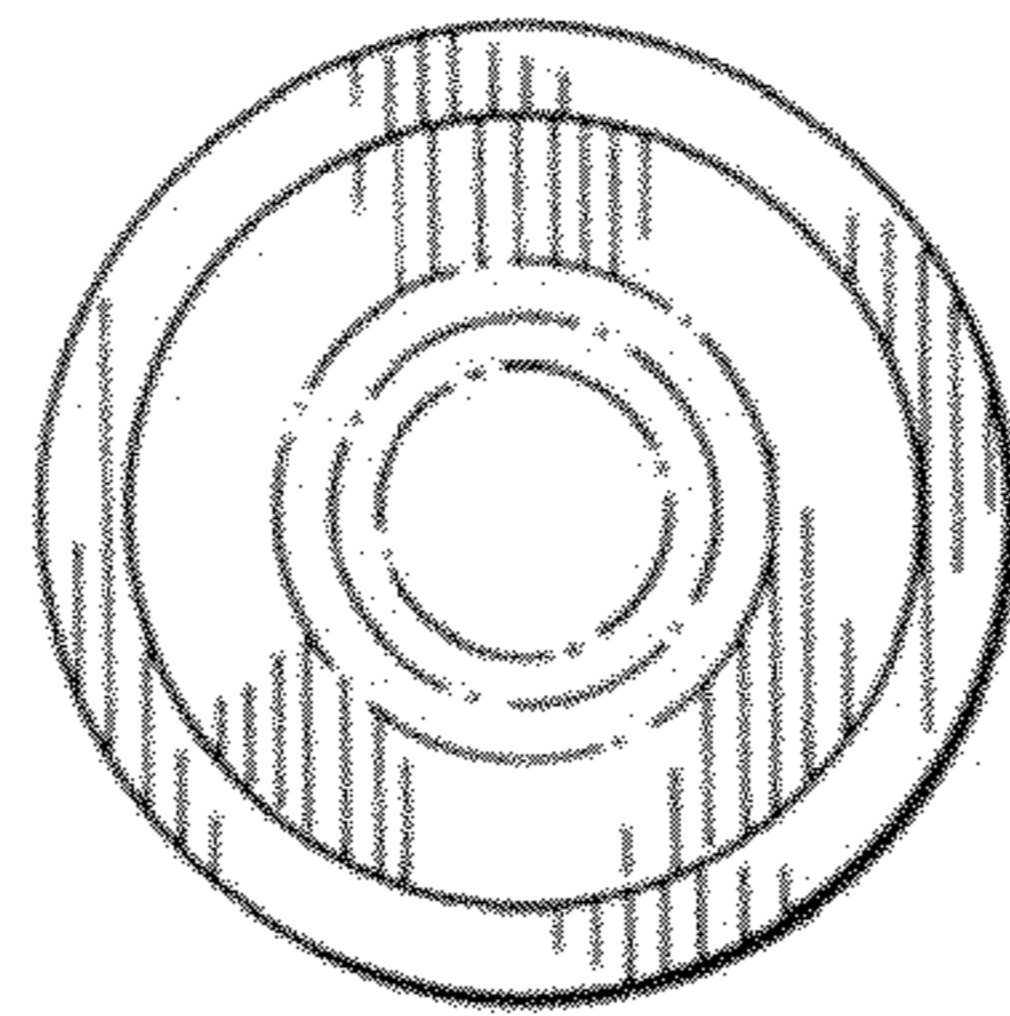

Fig. 7

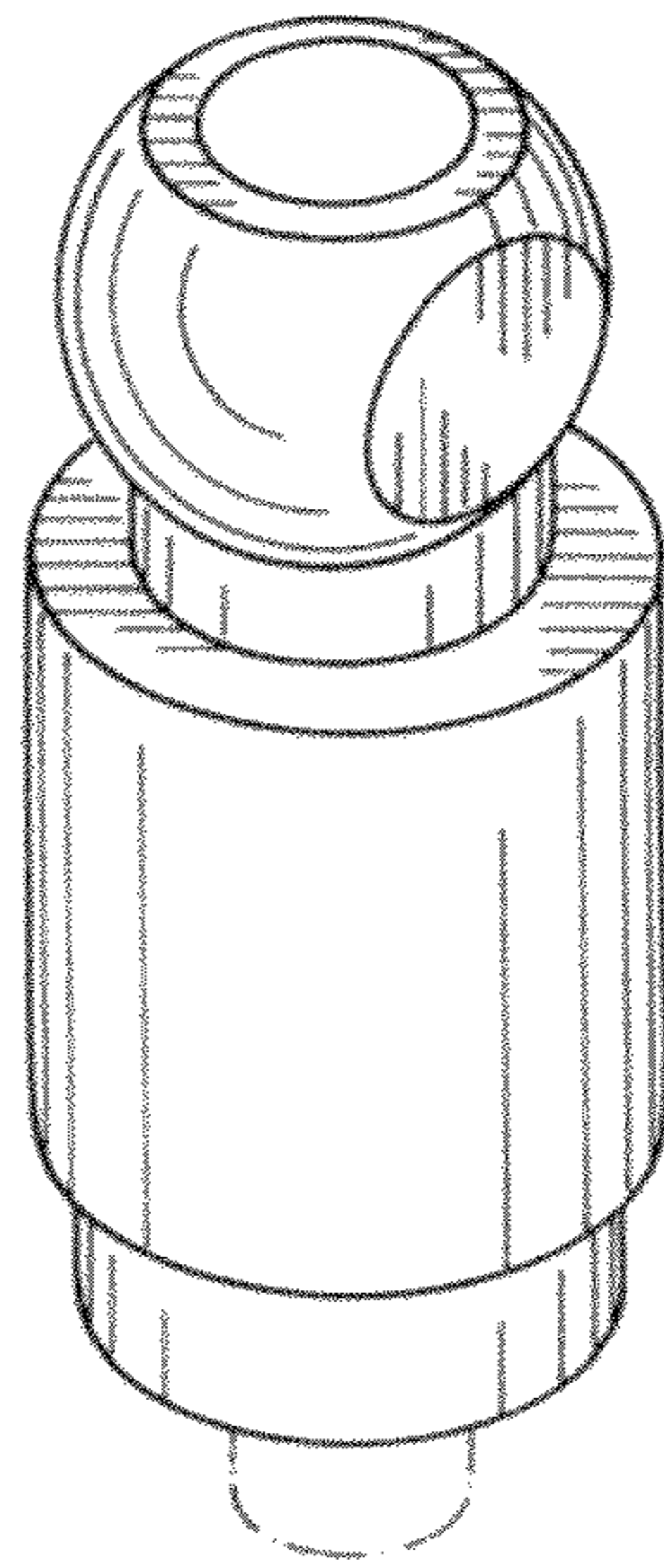

Fig. 8

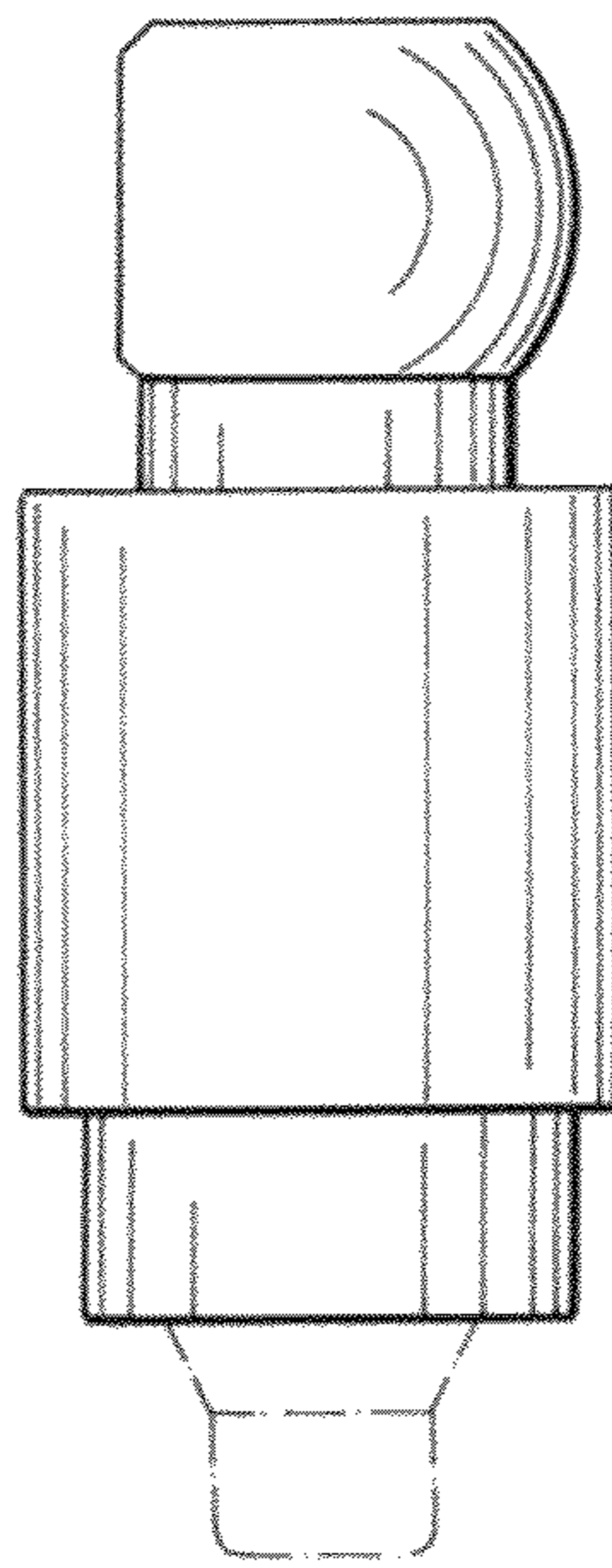

Fig. 9

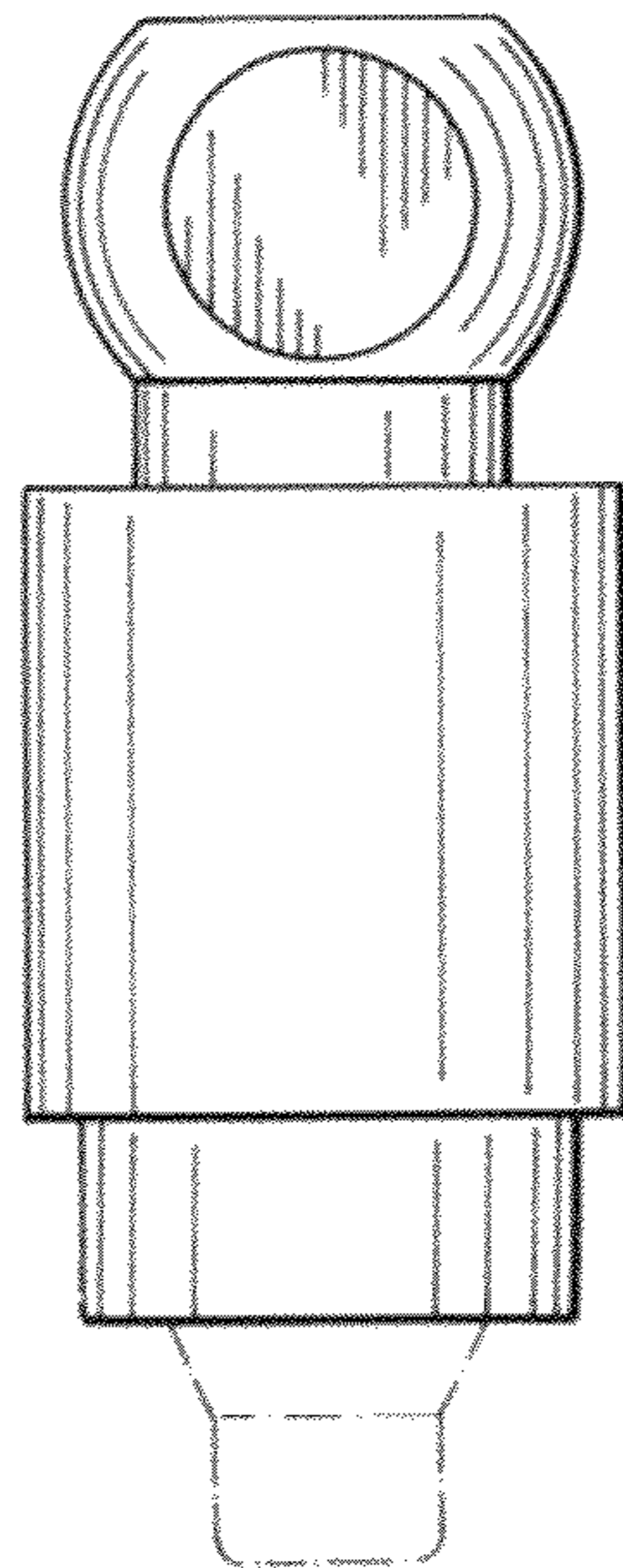

Fig. 10

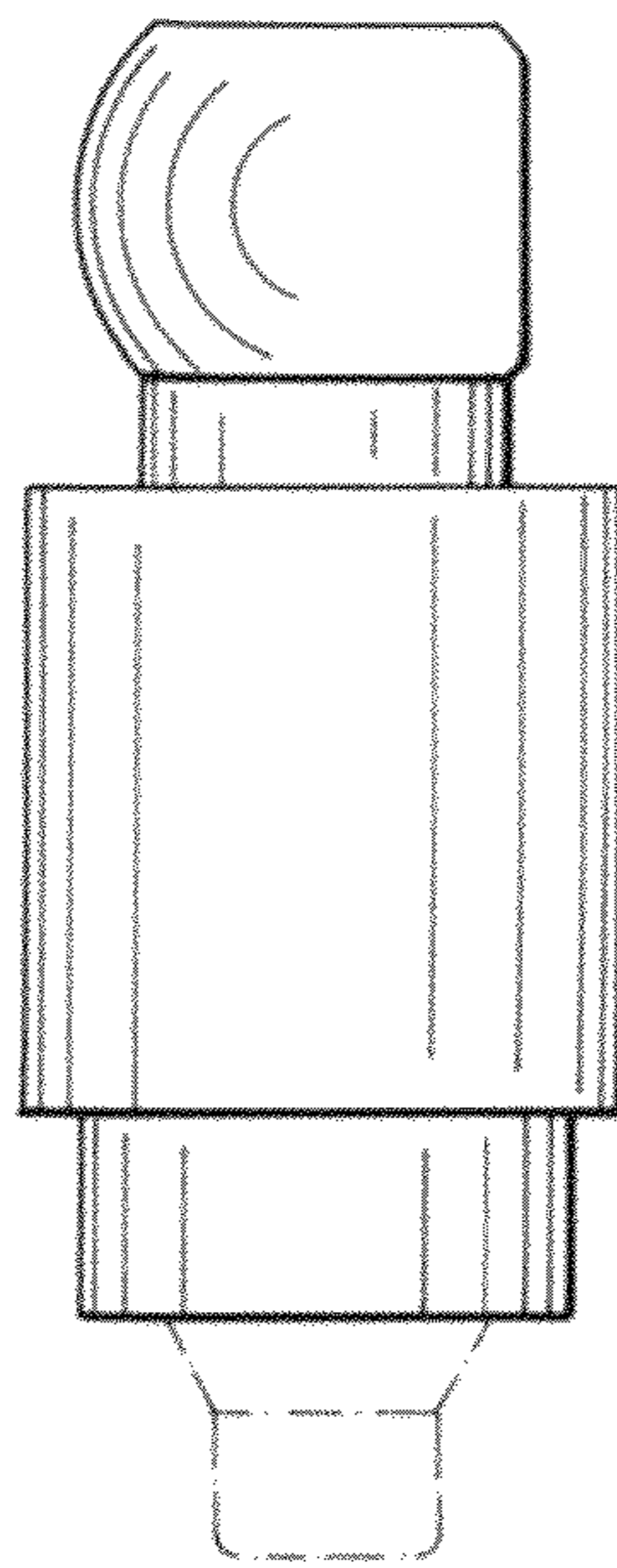

Fig. 11

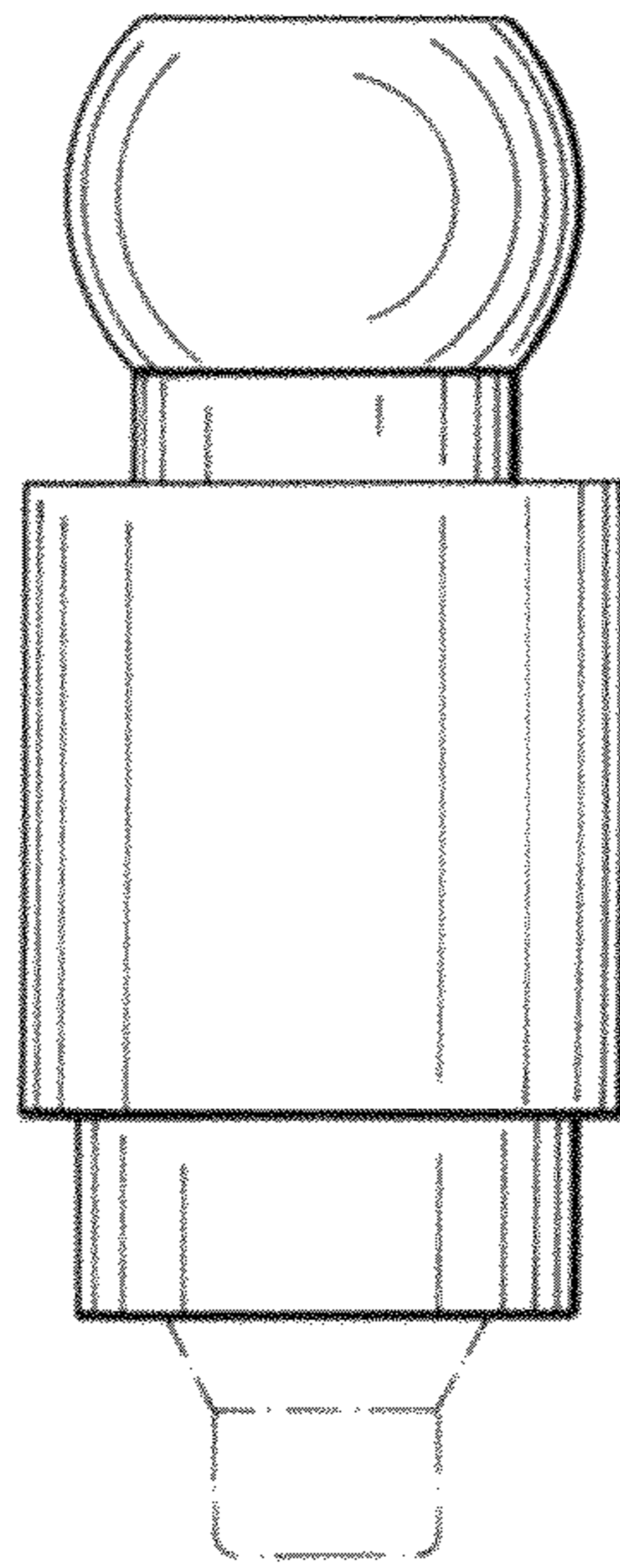

Fig. 12

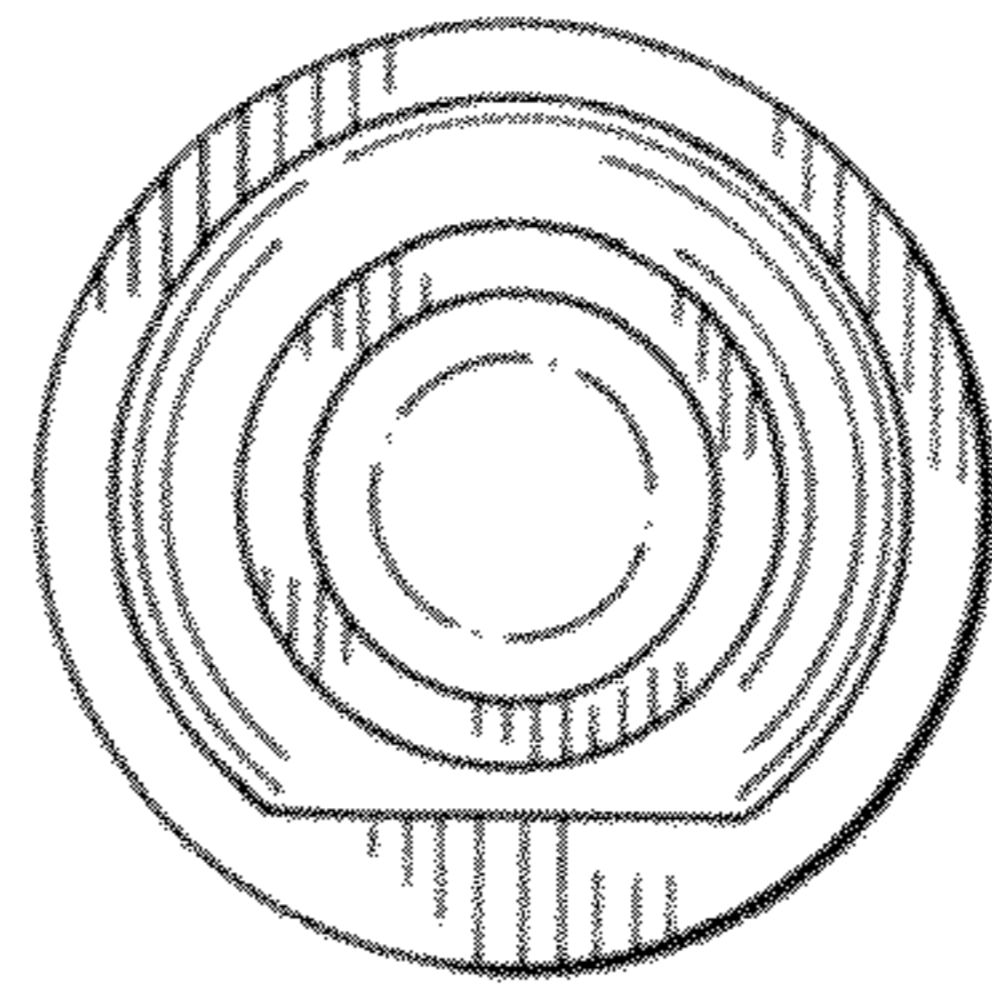

Fig. 13

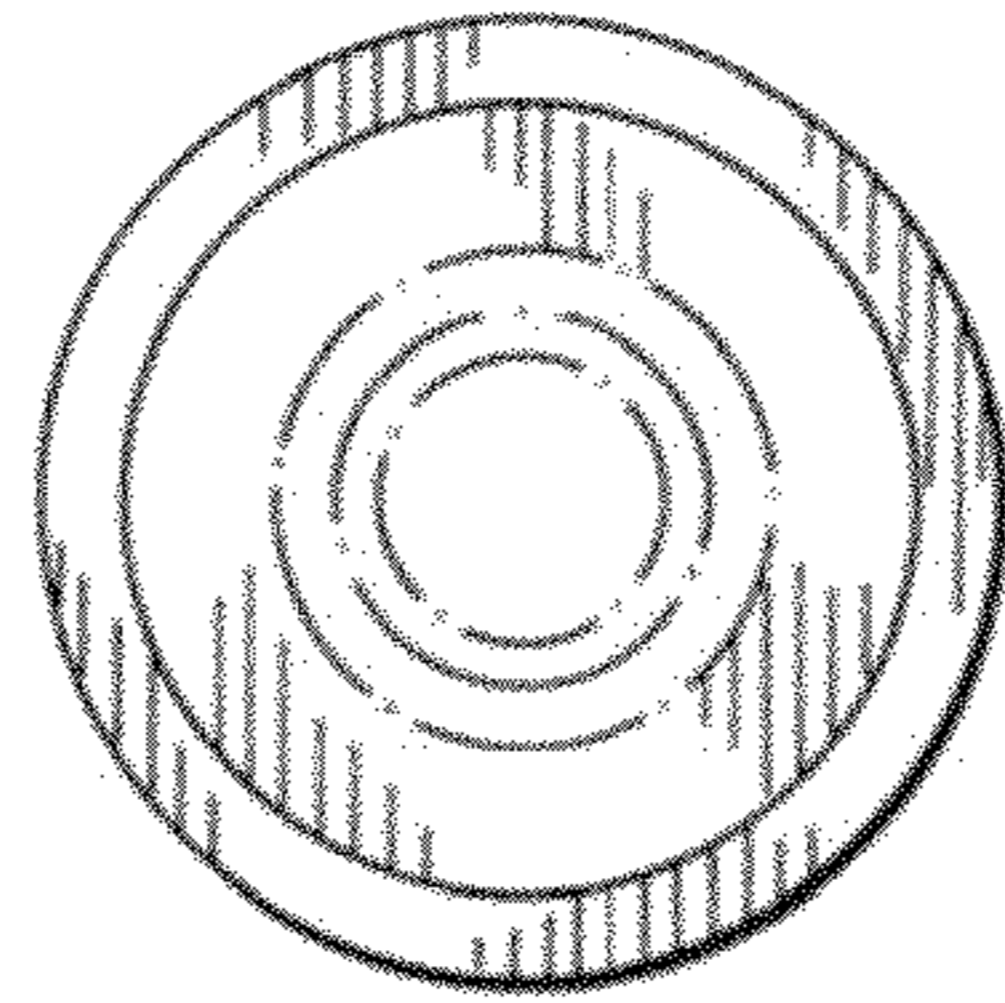

Fig. 14