



US00D688600S

(12) **United States Design Patent**
Kamler

(10) **Patent No.:** **US D688,600 S**

(45) **Date of Patent:** **** Aug. 27, 2013**

(54) **BICYCLE**

(76) Inventor: **Arnold Kamler**, Montville, NJ (US)

(**) Term: **14 Years**

(21) Appl. No.: **29/425,209**

(22) Filed: **Jun. 20, 2012**

(51) **LOC (9) Cl.** **12-11**

(52) **U.S. Cl.**
USPC **D12/111**

(58) **Field of Classification Search**
USPC D12/111, 117, 119; 280/274–280,
280/281.1, 283–288, 288.1–288.3
See application file for complete search history.

(56) **References Cited**

U.S. PATENT DOCUMENTS

| | | | | |
|-----------------|---------|---------------|-------|-----------|
| D155,745 S * | 10/1949 | Stevens | | D12/111 |
| D198,827 S * | 8/1964 | Schreckengost | | D12/111 |
| D398,562 S * | 9/1998 | Coker et al. | | D12/111 |
| 7,828,313 B1 * | 11/2010 | Cienfuegos | | 280/281.1 |
| D635,894 S * | 4/2011 | Argote Vivar | | D12/111 |
| 2012/0061941 A1 | 3/2012 | Choi et al. | | |

OTHER PUBLICATIONS

Twenty Nine Inches, "36 Inch Wheels: Update Part II," Feb. 23, 2008 by Guitar Ted, [online], [retrieved on Sep. 14, 2012]. Retrieved from the Internet: <URL: <http://twentynineinches.com/2008/02/23/36-inches-wheels-update-part-ii/>>, 4 pages.

MTO Bikes, "'Black Sheep' is No Misnomer," Mar. 17, 2009 by Bill Lobe, [online], [retrieved on Sep. 14, 2012]. Retrieved from the Internet: <URL: <http://mtobikes.com/black-sheep-bikes-zamer-36er-mountain-bike-review/>>, 9 pages.

Bike Hugger, "When 29 isn't enough—36 inch bike tires!," Sep. 26, 2007 by Dave R., [online], [retrieved on Sep. 14, 2012]. Retrieved

from the Internet: <URL: <http://bikehugger.com/post/view/when-29-isnt-enough-36-inch-bi>> 3 pages.

* cited by examiner

Primary Examiner — Susan M Lee

Assistant Examiner — Linda G Brooks

(74) *Attorney, Agent, or Firm* — Fitch, Even, Tabin & Flannery, LLP

(57) **CLAIM**

I claim the ornamental design for a bicycle, as shown and described.

DESCRIPTION

FIG. 1 is a perspective view of a first bicycle of my new design;

FIG. 2 is a right side elevational view of the bicycle of FIG. 1;

FIG. 3 is a left side elevational view of the bicycle of FIG. 1;

FIG. 4 is a front elevational view of the bicycle of FIG. 1;

FIG. 5 is a rear elevational view of the bicycle of FIG. 1;

FIG. 6 is a top plan view of the bicycle of FIG. 1;

FIG. 7 is a bottom plan view of the bicycle of FIG. 1;

FIG. 8 is perspective view of a second bicycle of my new design;

FIG. 9 is a right side elevational view of the bicycle of FIG. 8;

FIG. 10 is a left side elevational view of the bicycle of FIG. 8;

FIG. 11 is a front elevational view of the bicycle of FIG. 8;

FIG. 12 is a rear elevational view of the bicycle of FIG. 8;

FIG. 13 is a top plan view of the bicycle of FIG. 8; and,

FIG. 14 is a bottom plan view of the bicycle of FIG. 8.

Any components in the appended drawings shown in broken lines are for illustrative purposes only and form no part of the claimed design or a specified embodiment thereof.

1 Claim, 12 Drawing Sheets

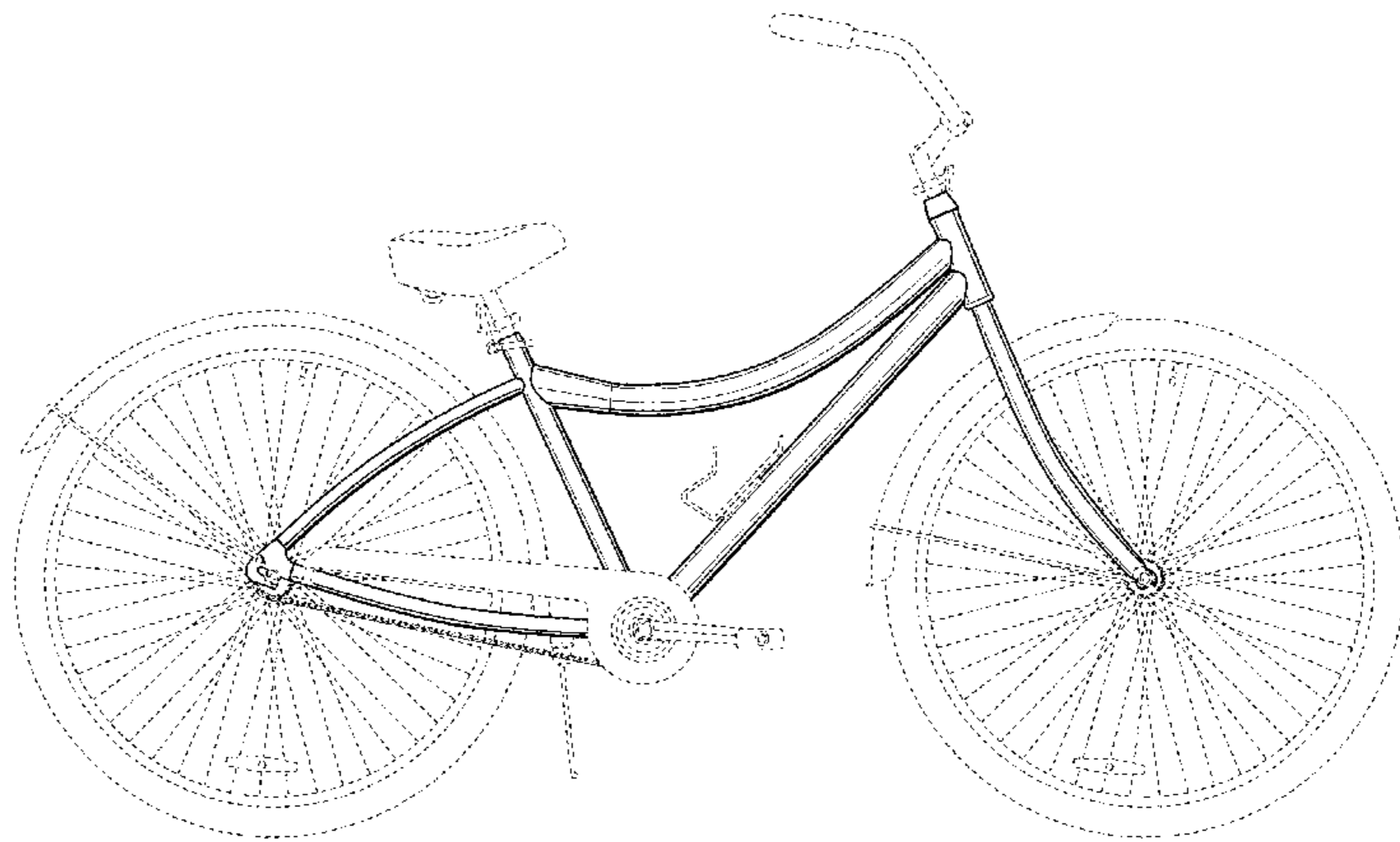
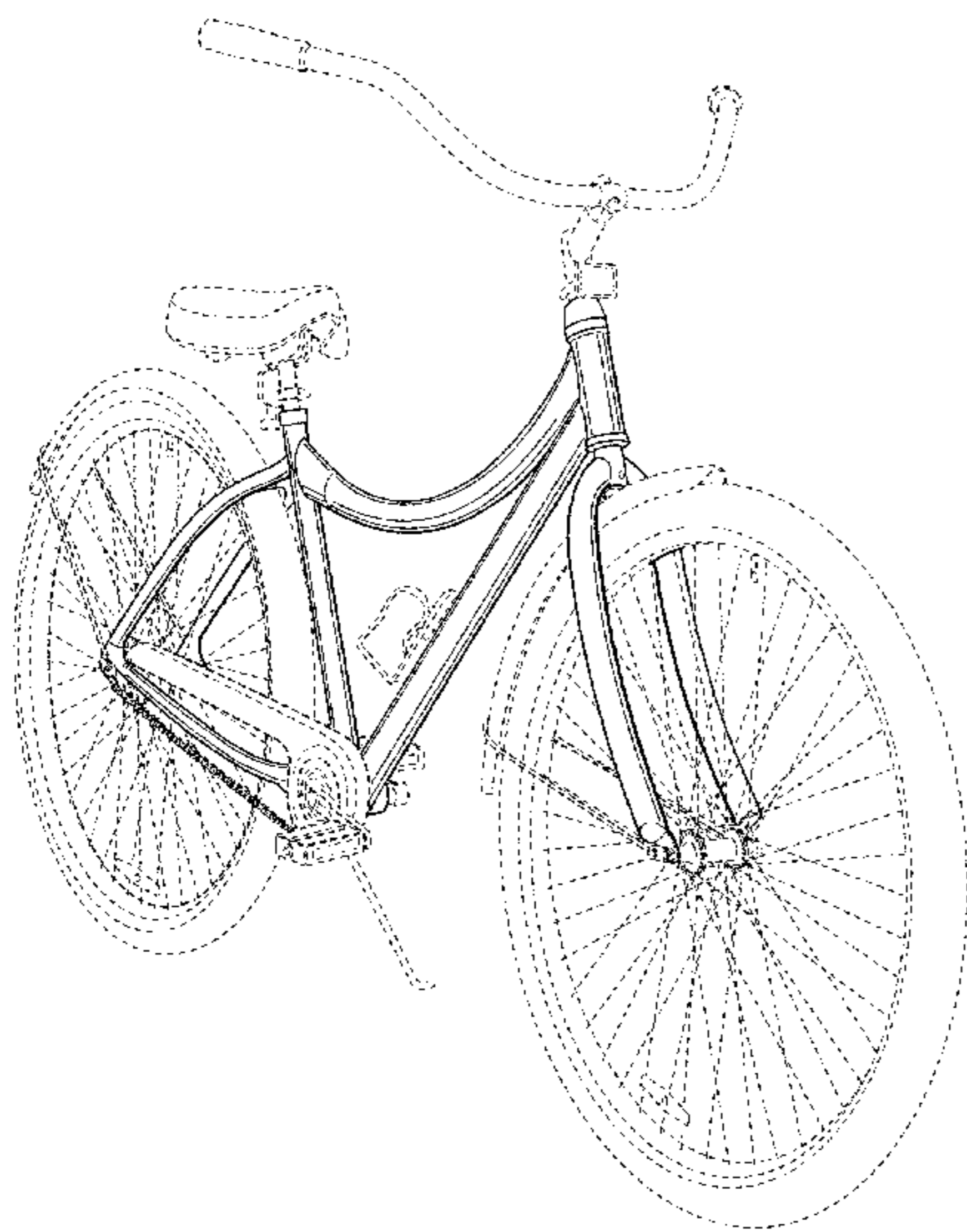

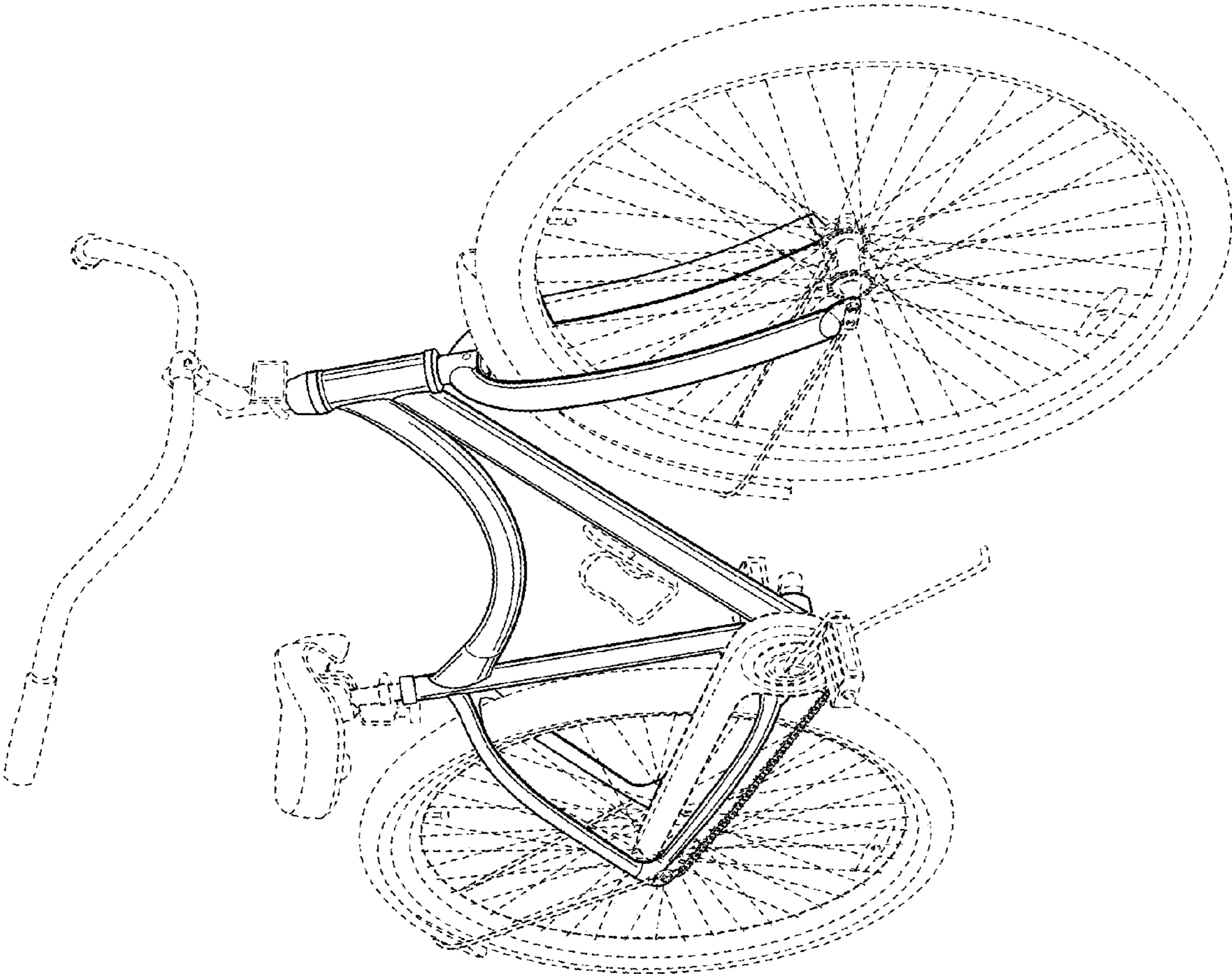

Fig. 1

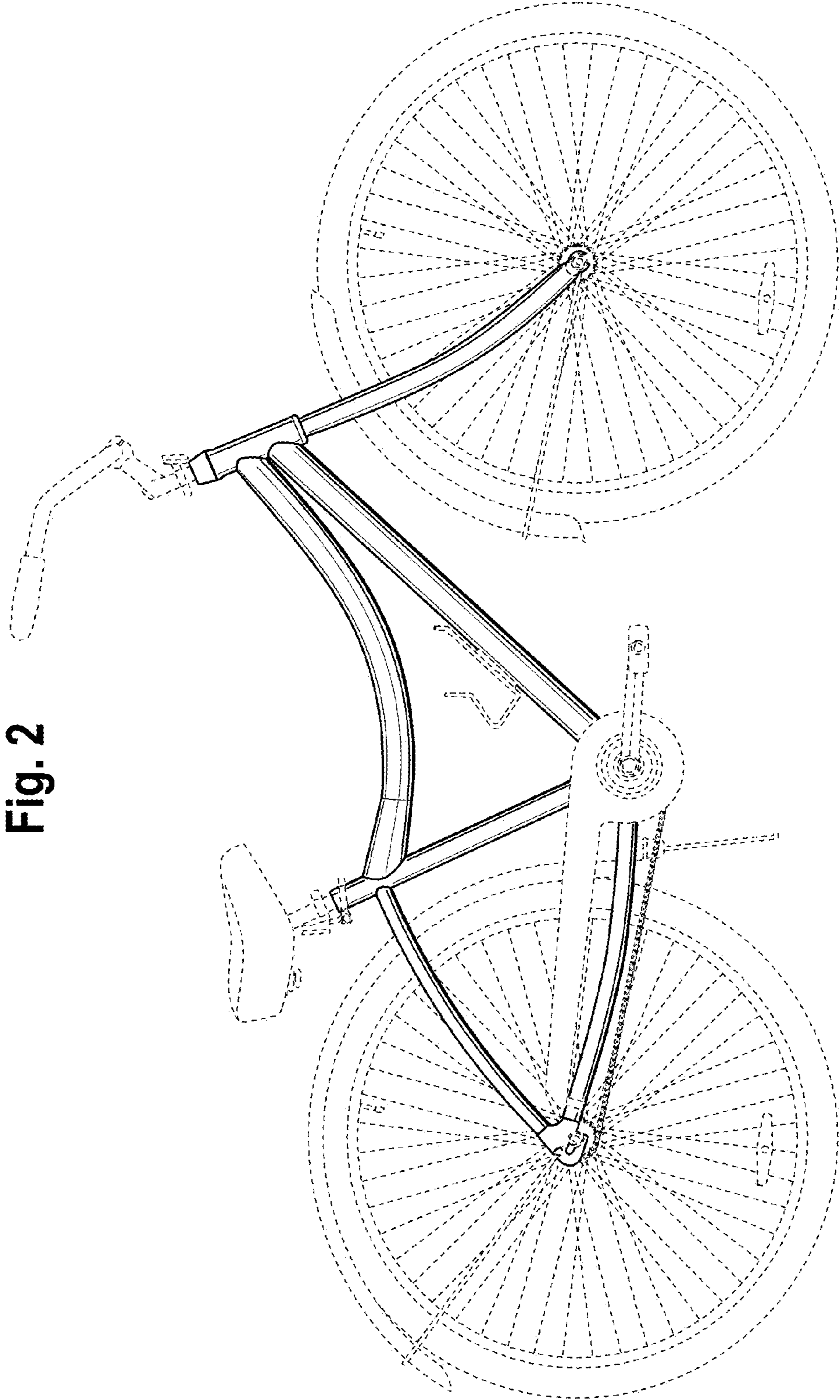

Fig. 2

Fig. 3

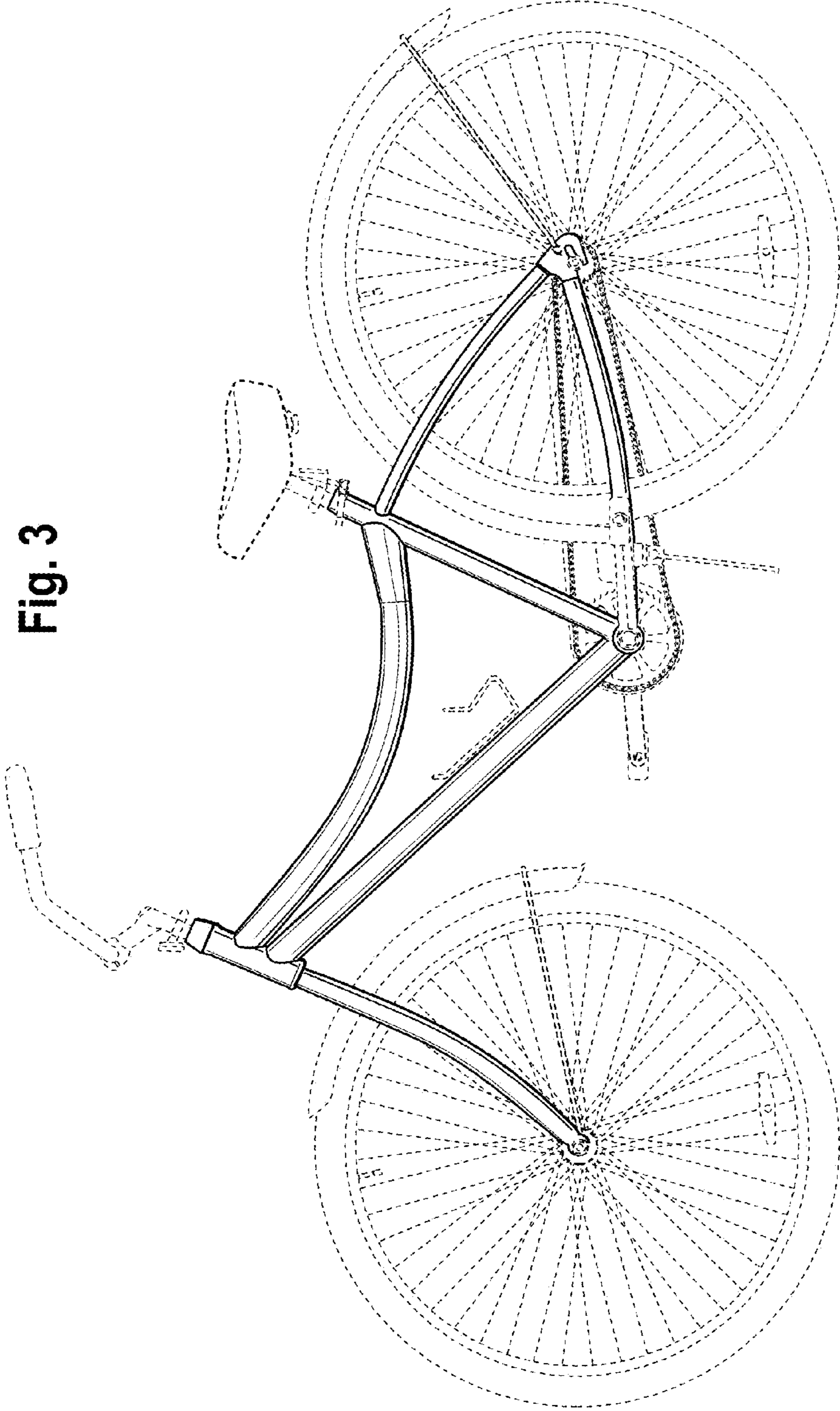

Fig. 5

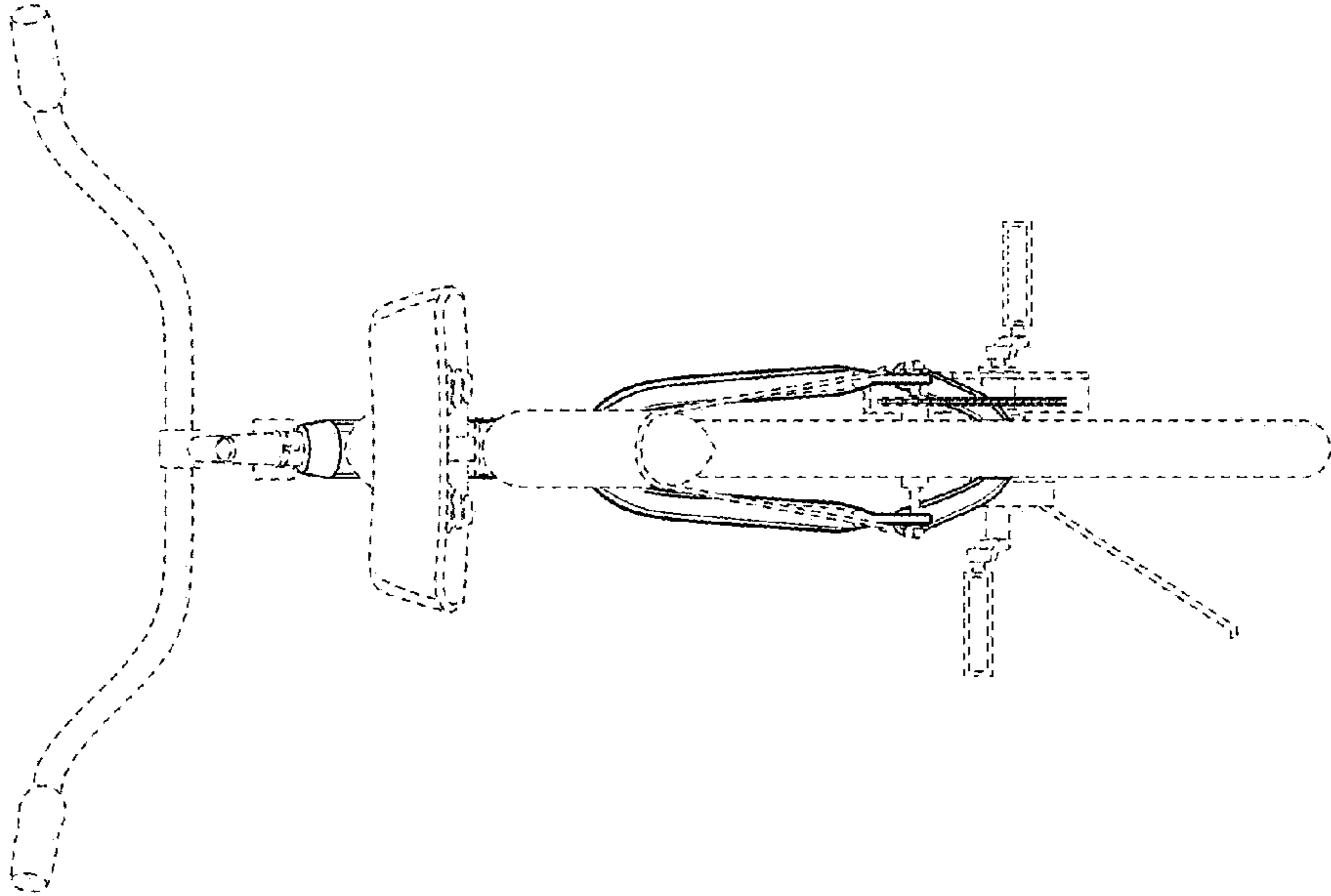
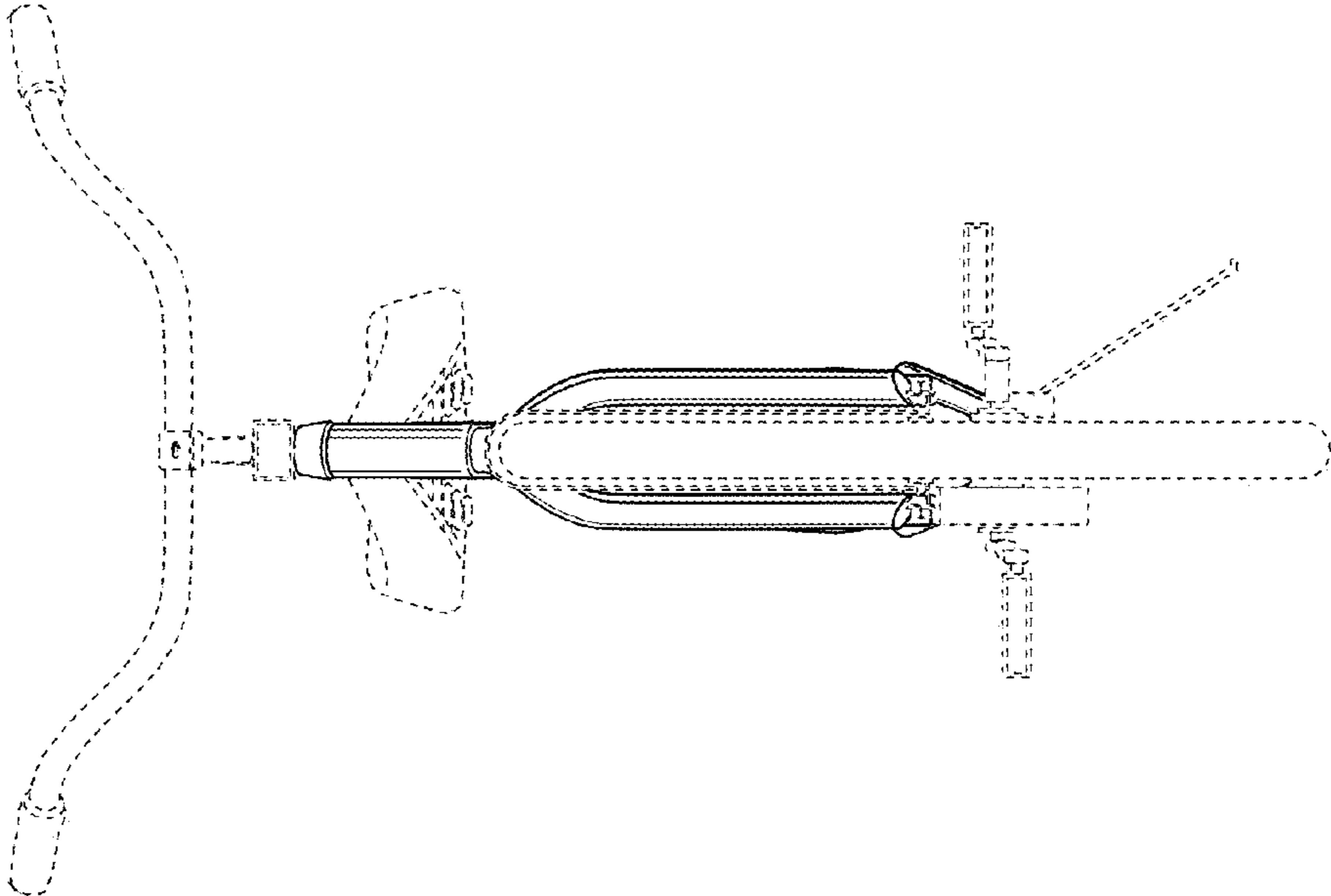

Fig. 4



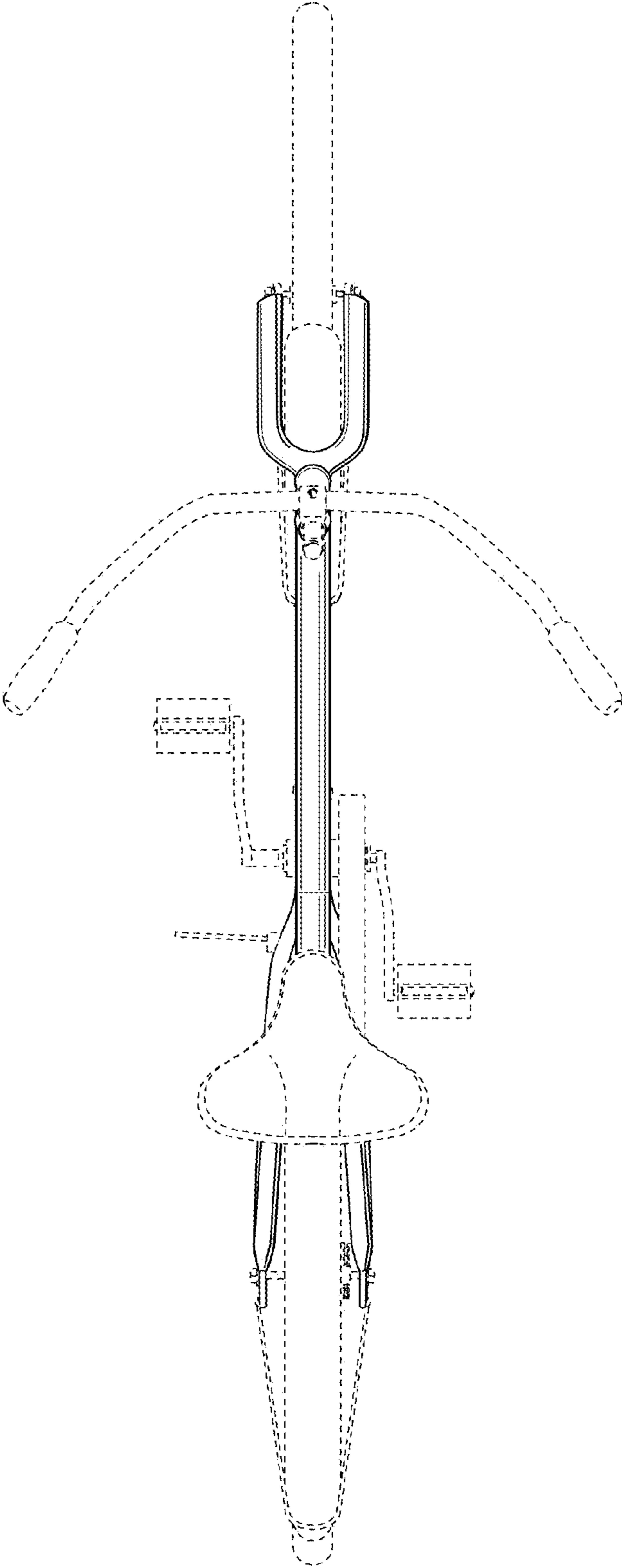

Fig. 6

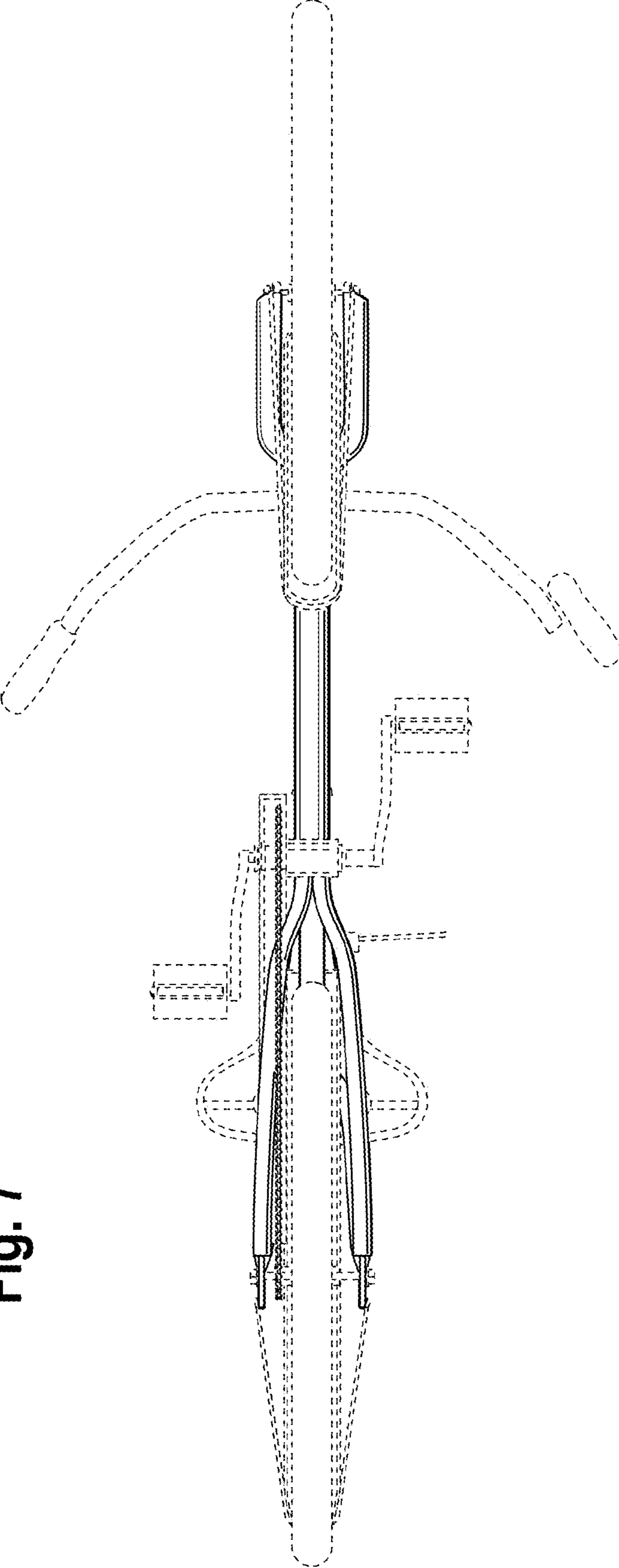

Fig. 7

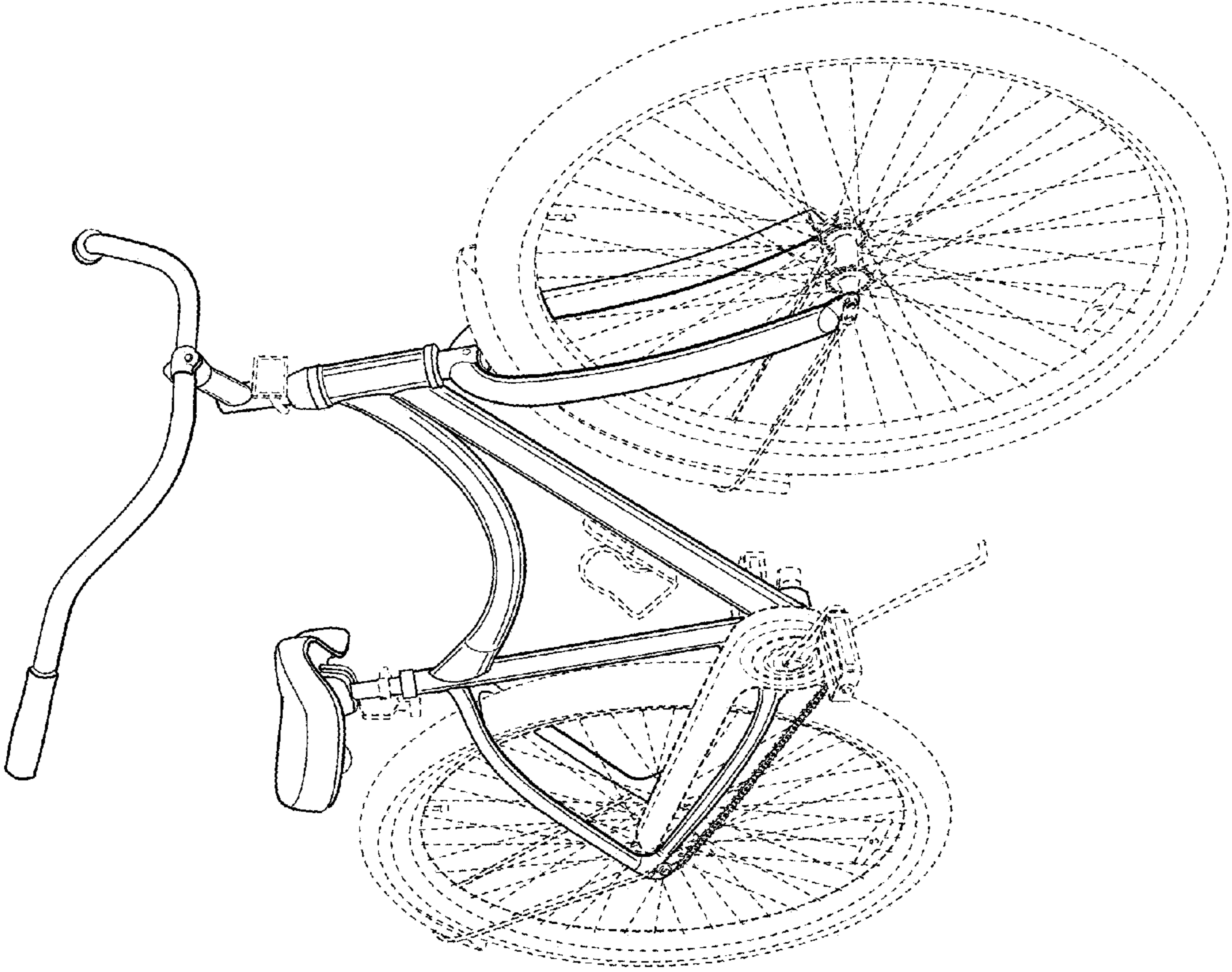

Fig. 8

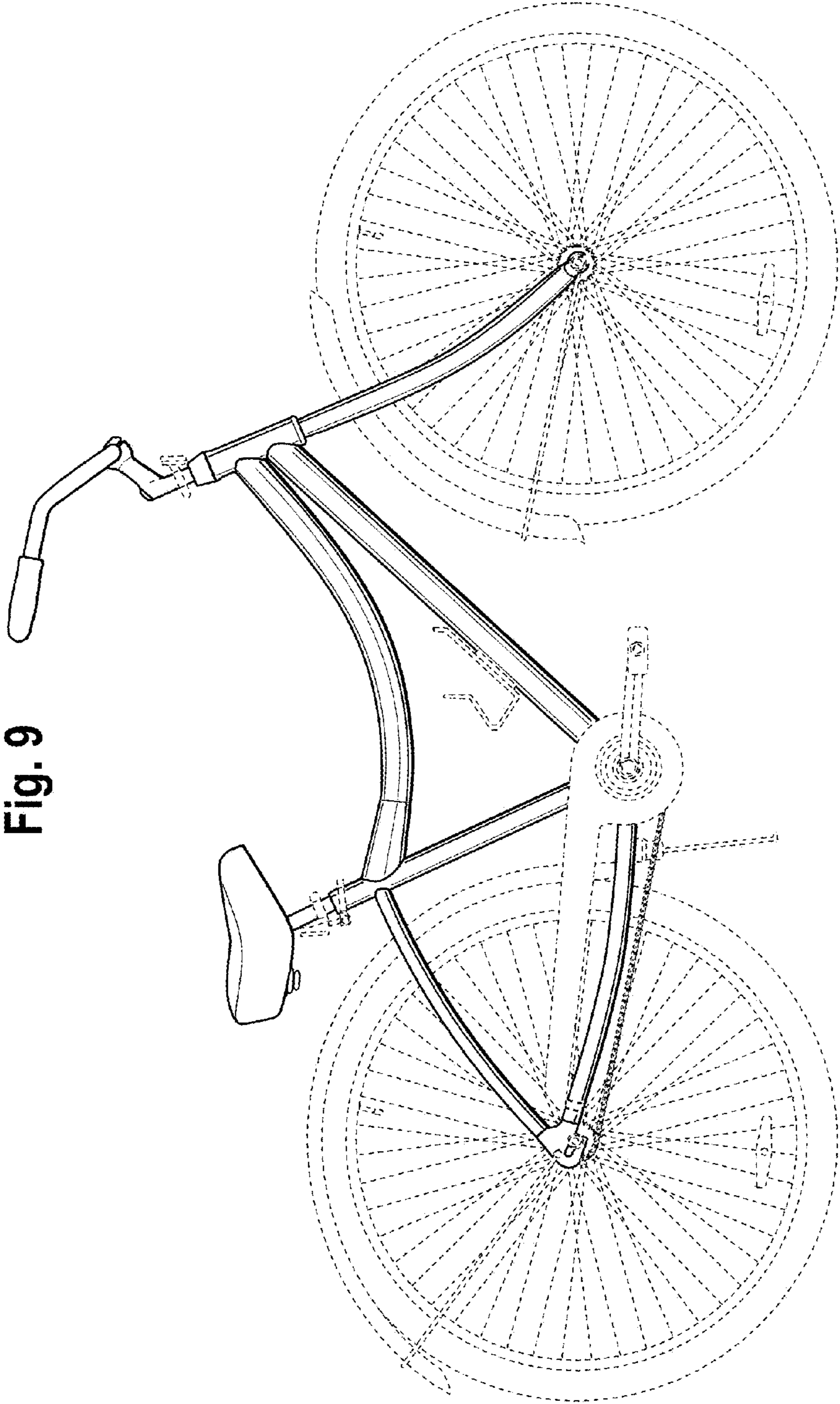

Fig. 9

Fig. 10

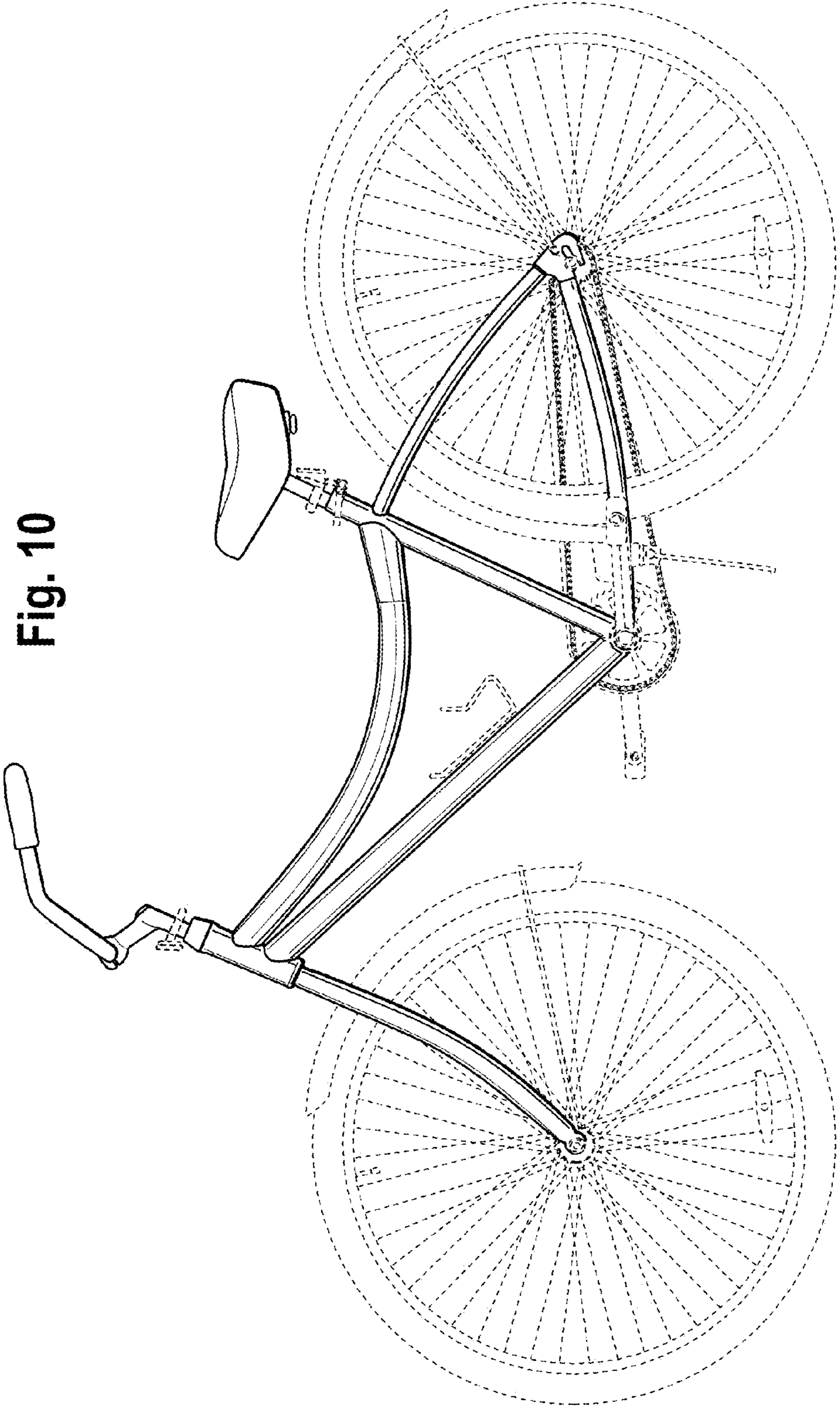

Fig. 12

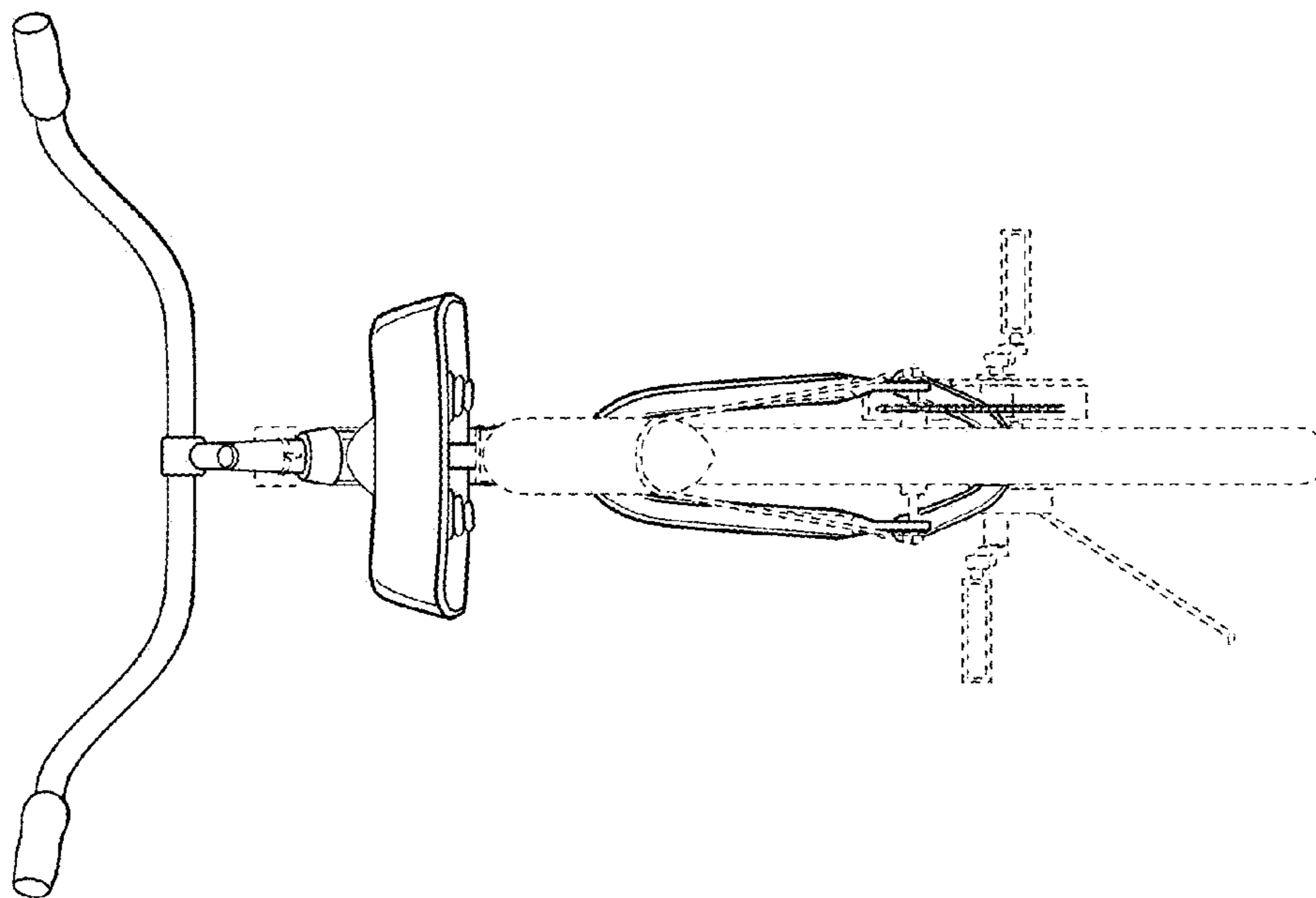
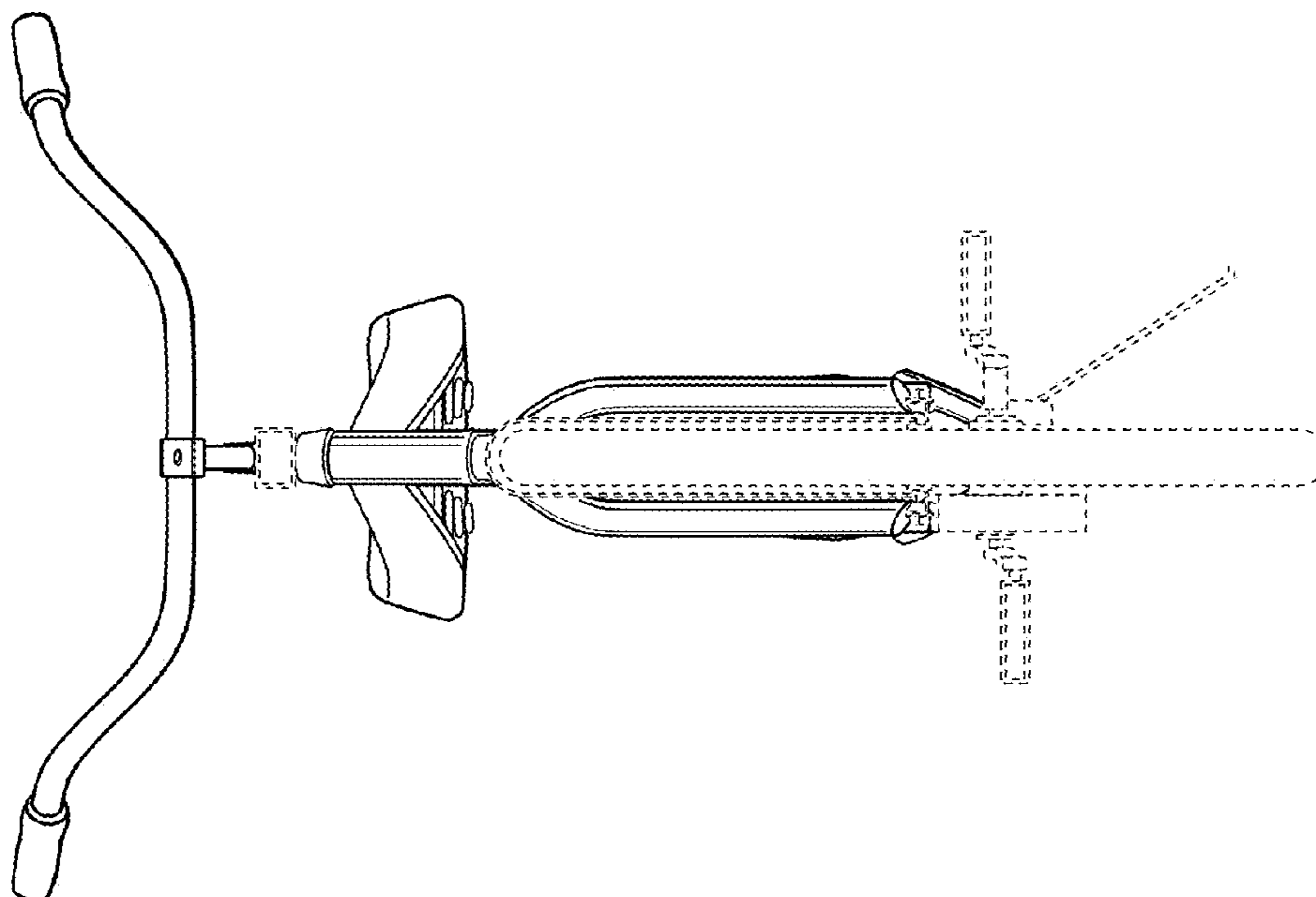

Fig. 11



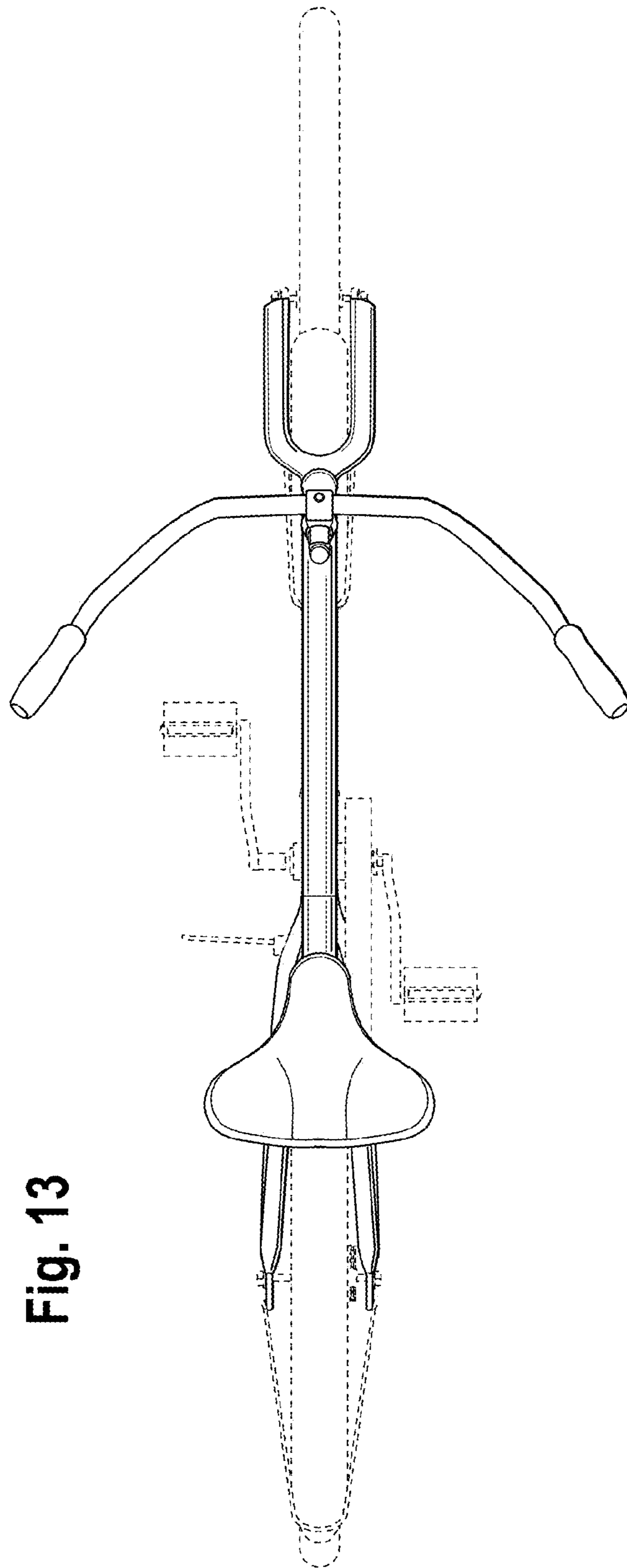

Fig. 13

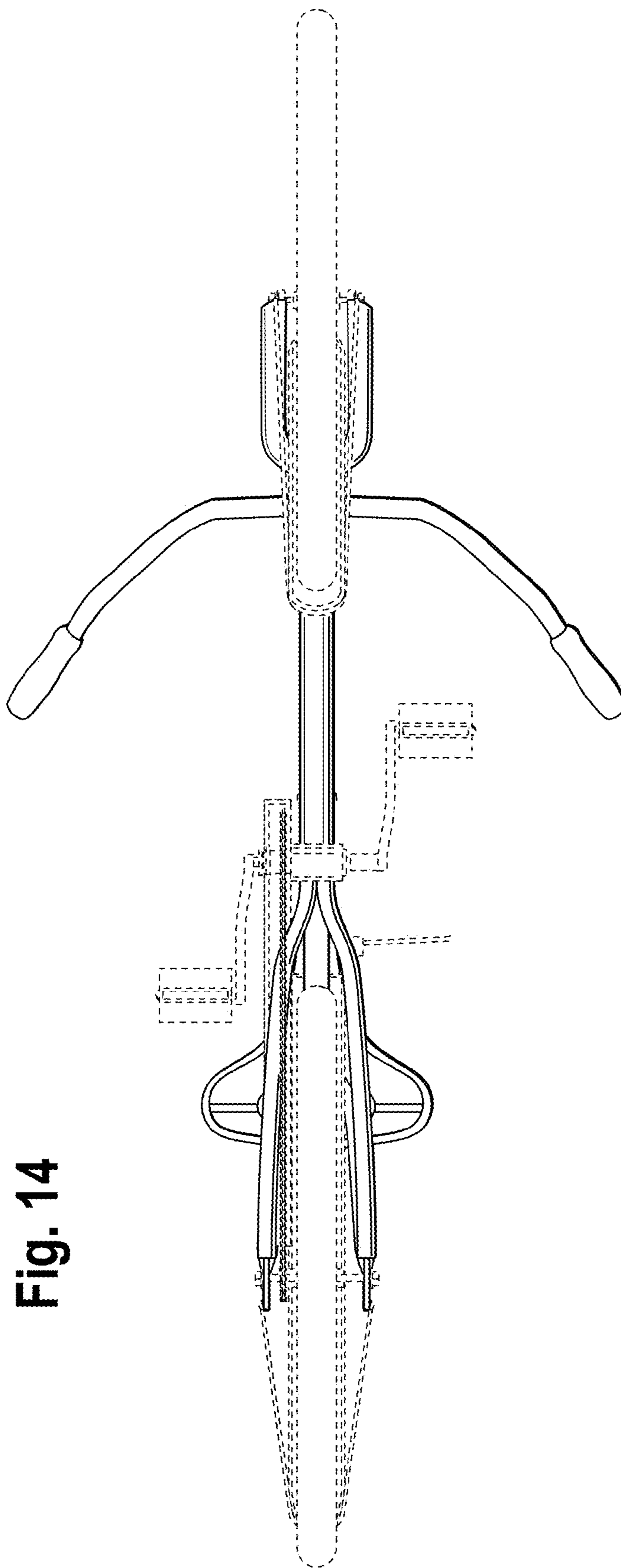

Fig. 14