



US00D688179S

(12) **United States Design Patent**  
**Ali et al.**

(10) **Patent No.:** **US D688,179 S**

(45) **Date of Patent:** **\*\* Aug. 20, 2013**

(54) **AUTOMOBILE HEADLINER**

(56) **References Cited**

(75) Inventors: **Zulfiquar Ali**, West Bloomfield, MI (US); **Everard Scott**, Sterling Heights, MI (US); **Khashayar Honarkhah**, Bloomfield Hills, MI (US)

(73) Assignee: **Chrysler Group LLC**, Auburn Hills, MI (US)

(\*\*) Term: **14 Years**

(21) Appl. No.: **29/410,468**

(22) Filed: **Jan. 9, 2012**

(51) **LOC (9) Cl.** ..... **12-16**

(52) **U.S. Cl.**  
USPC ..... **D12/195**

(58) **Field of Classification Search**  
USPC ..... D12/195, 193, 414, 190, 196; 180/190; 280/750-752; 296/190.01-191, 70, 193.08, 296/145, 153, 37.1-37.13, 149, 146.1; D15/17, D15/28; D10/46, 98, 102-103; 49/501-502; D8/302-303

See application file for complete search history.

U.S. PATENT DOCUMENTS

D282,733	S	*	2/1986	Giavazzi et al. ....	D12/195
4,867,498	A	*	9/1989	Delphia et al. ....	296/37.7
D340,017	S	*	10/1993	Falcoff .....	D12/418
6,338,517	B1	*	1/2002	Canni et al. ....	296/37.8
D496,618	S	*	9/2004	Nakajima et al. ....	D12/195
6,896,321	B2	*	5/2005	Vishey et al. ....	296/214
D539,212	S	*	3/2007	Maezono et al. ....	D12/418
D575,724	S	*	8/2008	Tsay et al. ....	D12/418
D580,345	S	*	11/2008	Paxton et al. ....	D12/418
D590,764	S	*	4/2009	Yu .....	D12/418
D592,585	S	*	5/2009	Moburg et al. ....	D12/418

\* cited by examiner

*Primary Examiner* — Katrina A Betton

(74) *Attorney, Agent, or Firm* — Ralph E Smith

(57) **CLAIM**

The ornamental design for an automobile headliner, as shown and described.

**DESCRIPTION**

FIG. 1 is a left perspective view of an automobile headliner showing our new design; FIG. 2 is a right perspective view thereof; FIG. 3 is a front perspective view thereof; and, FIG. 4 is a bottom plan view thereof. In the drawings, the broken lines depict an automobile interior and form no part of the claimed design.

**1 Claim, 4 Drawing Sheets**

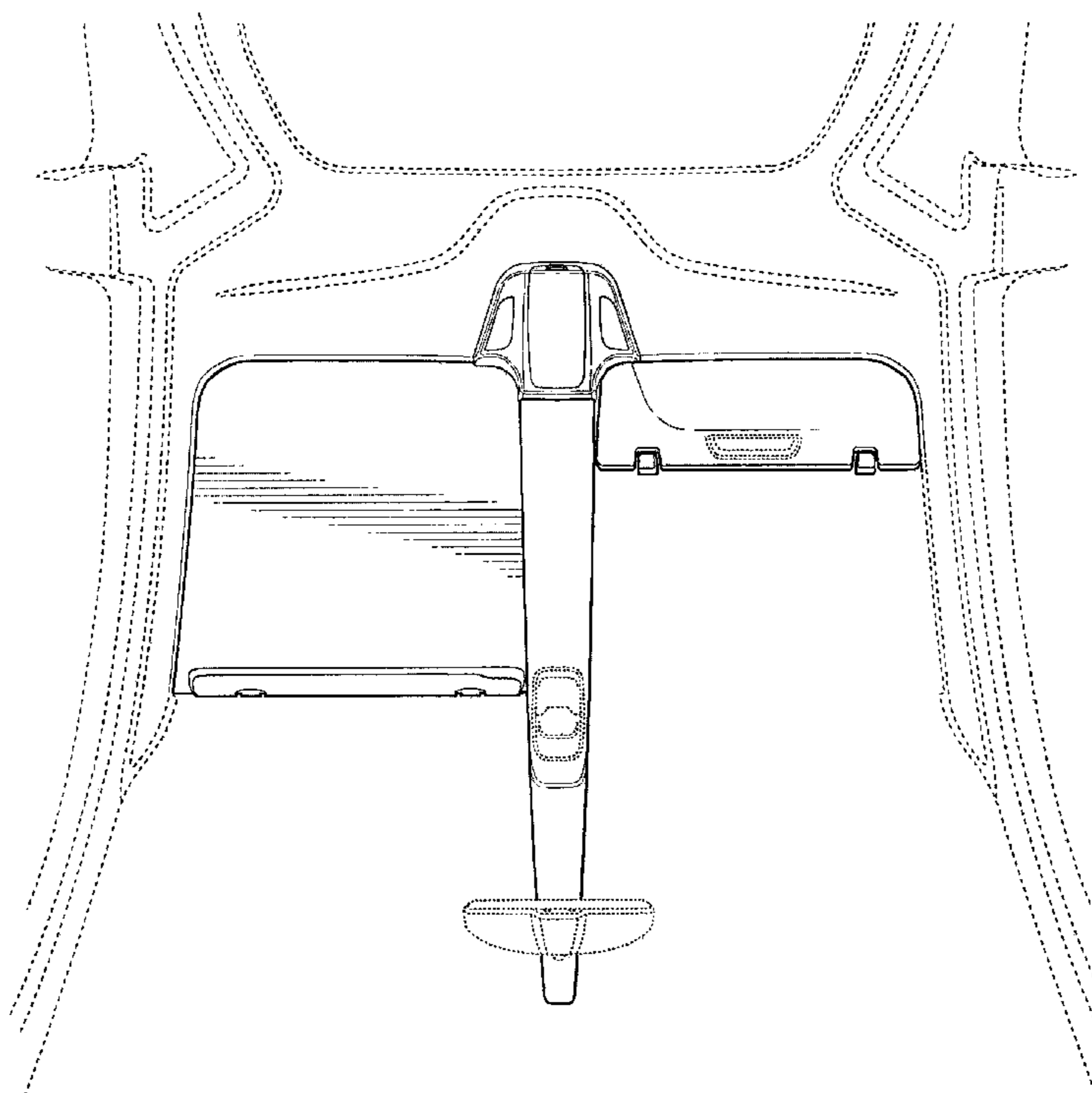

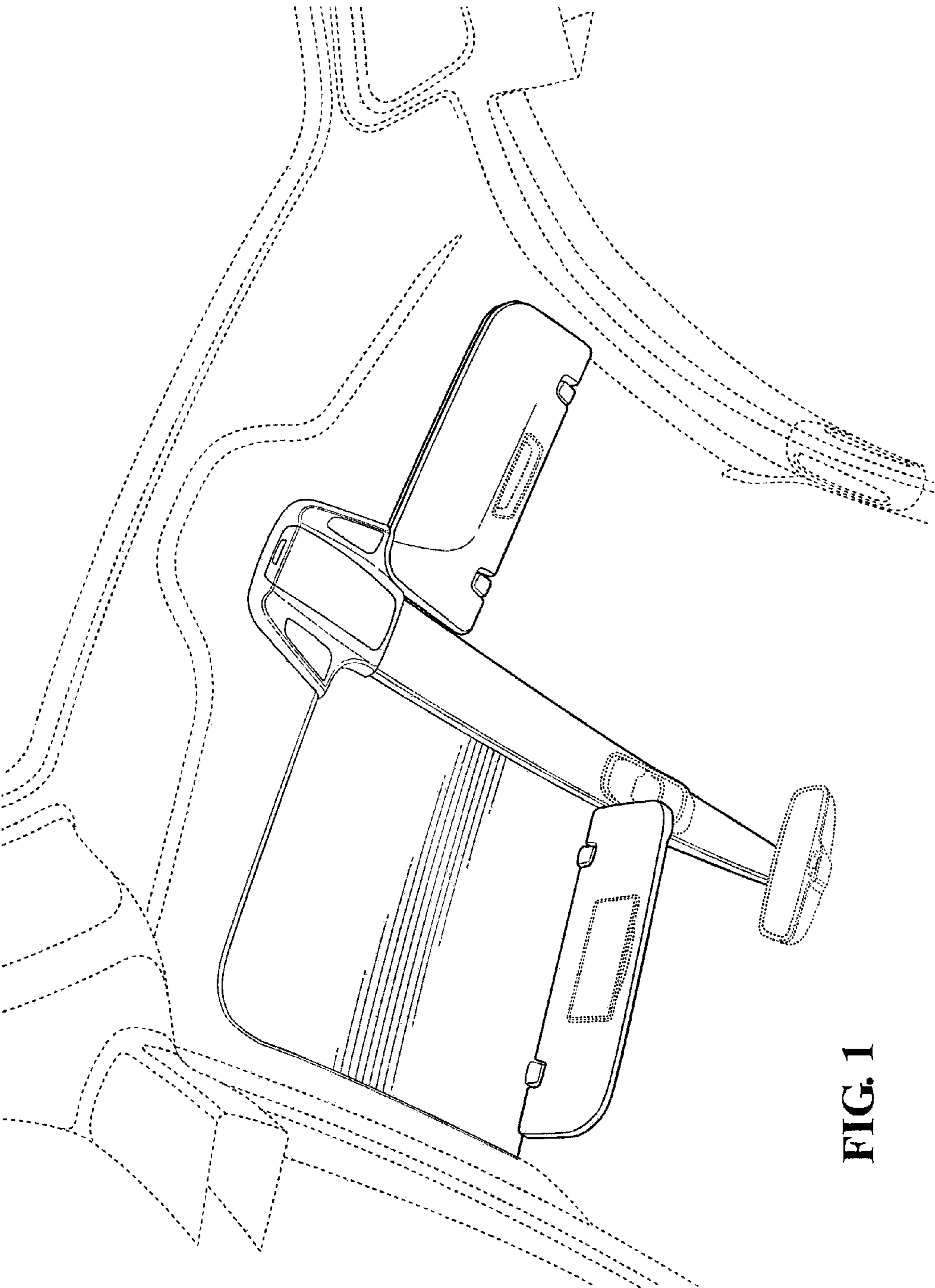

FIG. 1

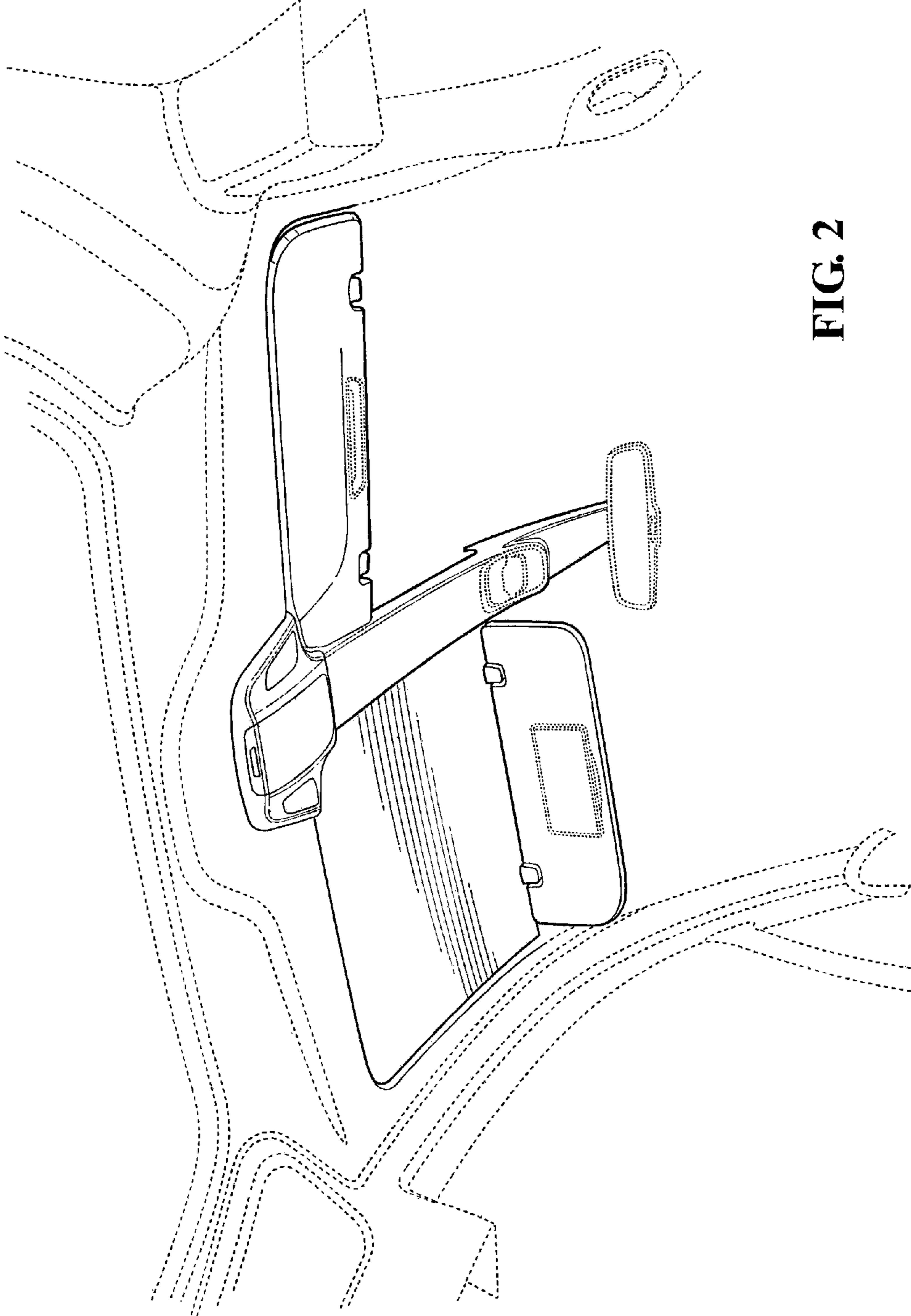

FIG. 2

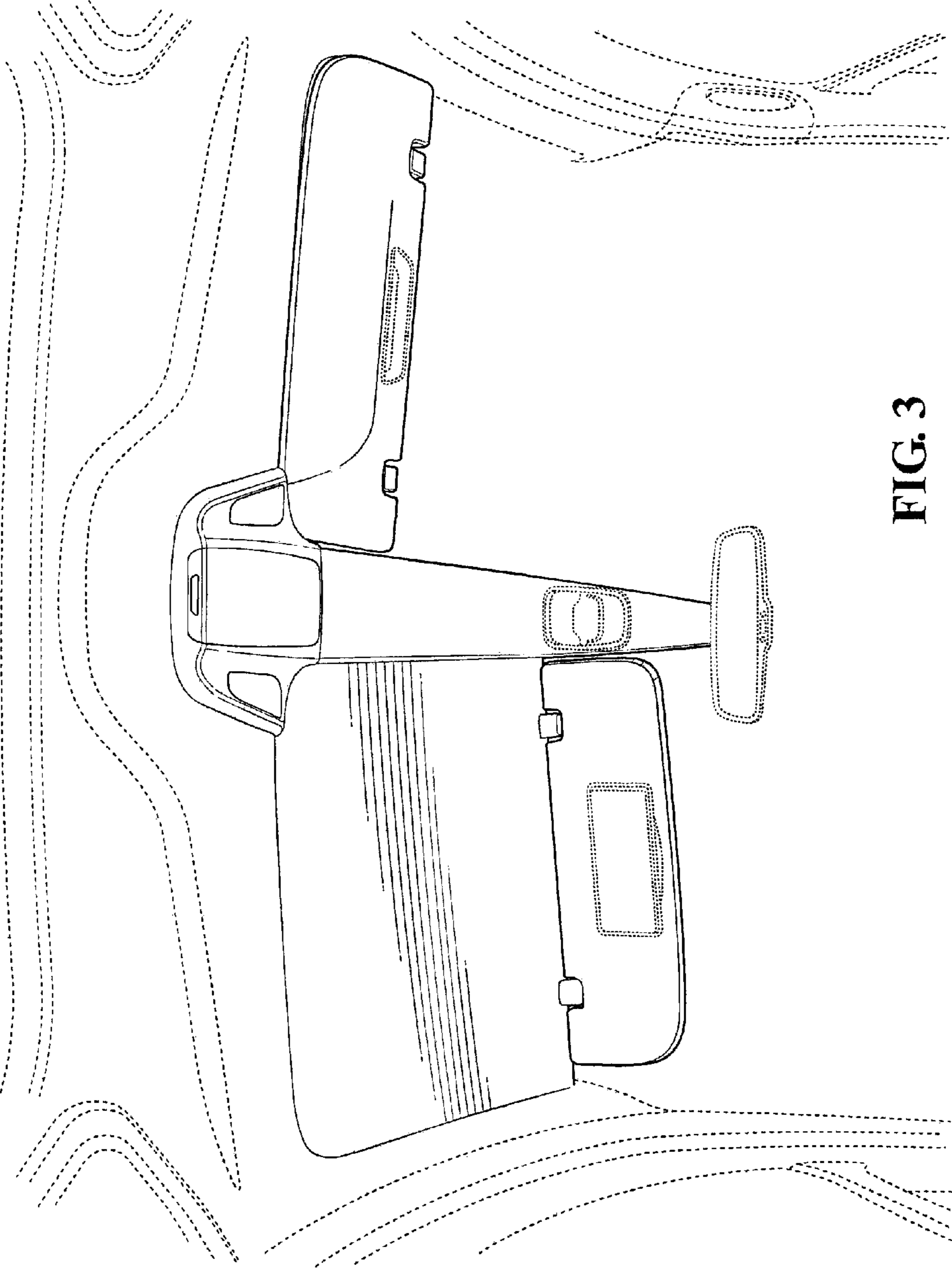

FIG. 3

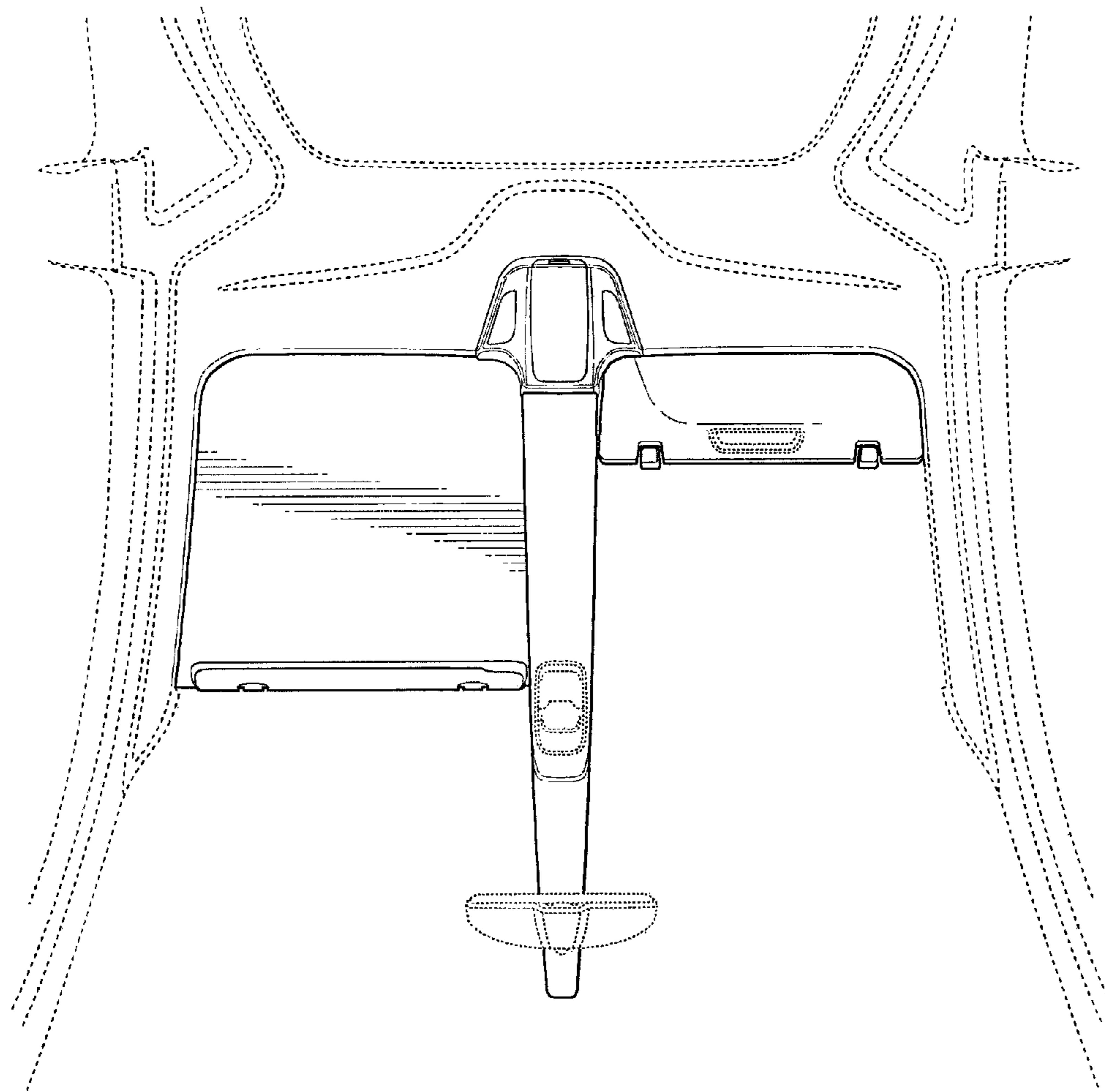

FIG. 4