



US00D687923S

(12) **United States Design Patent**
Jung et al.

(10) **Patent No.:** **US D687,923 S**
(45) **Date of Patent:** **** Aug. 13, 2013**

(54) **LUBRICANT DISPENSING NOZZLE**

(75) Inventors: **Jim Jung**, Delafield, WI (US); **Dan Freeland**, West Allis, WI (US); **Nick Corgiat**, Oconomowoc, WI (US); **Lisa Kiepert**, Sussex, WI (US); **Dan Gundrum**, Slinger, WI (US)

(73) Assignee: **Trico Corporation**, Pewaukee, WI (US)

(**) Term: **14 Years**

(21) Appl. No.: **29/419,157**

(22) Filed: **Apr. 25, 2012**

Related U.S. Application Data

(63) Continuation-in-part of application No. 12/156,733, filed on Jun. 3, 2008, now Pat. No. 8,220,671.

(51) **LOC (9) Cl.** **23-01**

(52) **U.S. Cl.**
USPC **D23/211.2; D9/447**

(58) **Field of Classification Search**
USPC D9/434, 435, 447, 516, 526, 527, D9/682, 723-729; 215/381-385; 220/660, 220/669, 675; D23/211.1, 211.2; D8/2
See application file for complete search history.

(56) **References Cited**

U.S. PATENT DOCUMENTS

126,624 A	5/1872	Coffee
539,117 A	5/1895	Busch
779,357 A	1/1905	Gardner
805,645 A	11/1905	Guillott
992,503 A	5/1911	Howard
1,113,276 A	10/1914	Woodmansee
1,571,495 A	2/1926	Smith

(Continued)

FOREIGN PATENT DOCUMENTS

CA	2291763	7/2002
CA	2289726	3/2003

(Continued)

OTHER PUBLICATIONS

International Search Report, dated Jan. 20, 1999 for PCT/US98/09039, International Filing Date May 8, 1998.

(Continued)

Primary Examiner — Keli L Hill

(74) *Attorney, Agent, or Firm* — Ryan Kromholz & Manion, S.C.

(57) **CLAIM**

The ornamental design for a lubricant dispenser, as shown and described.

DESCRIPTION

FIG. 1 is a perspective view of the lubricant dispensing nozzle of the present invention, with portions exploded;
 FIG. 2 is a perspective view of the lubricant dispensing nozzle of the present invention;
 FIG. 3 first side view of the lubricant dispensing nozzle of the present invention;
 FIG. 4 is a second side view of the lubricant dispensing nozzle of the present invention;
 FIG. 5 is a front view of the lubricant dispensing nozzle of the present invention;
 FIG. 6 is a top view of the lubricant container of the present invention; and
 FIG. 7 is a top view of the lubricant dispensing nozzle of the present invention; and,
 FIG. 8 is a bottom view of the lubricant dispensing nozzle of the present invention.
 The broken lines shown are included for the purpose of illustrating the unclaimed portions of the lubricant dispenser and form no part of the claim.

1 Claim, 4 Drawing Sheets

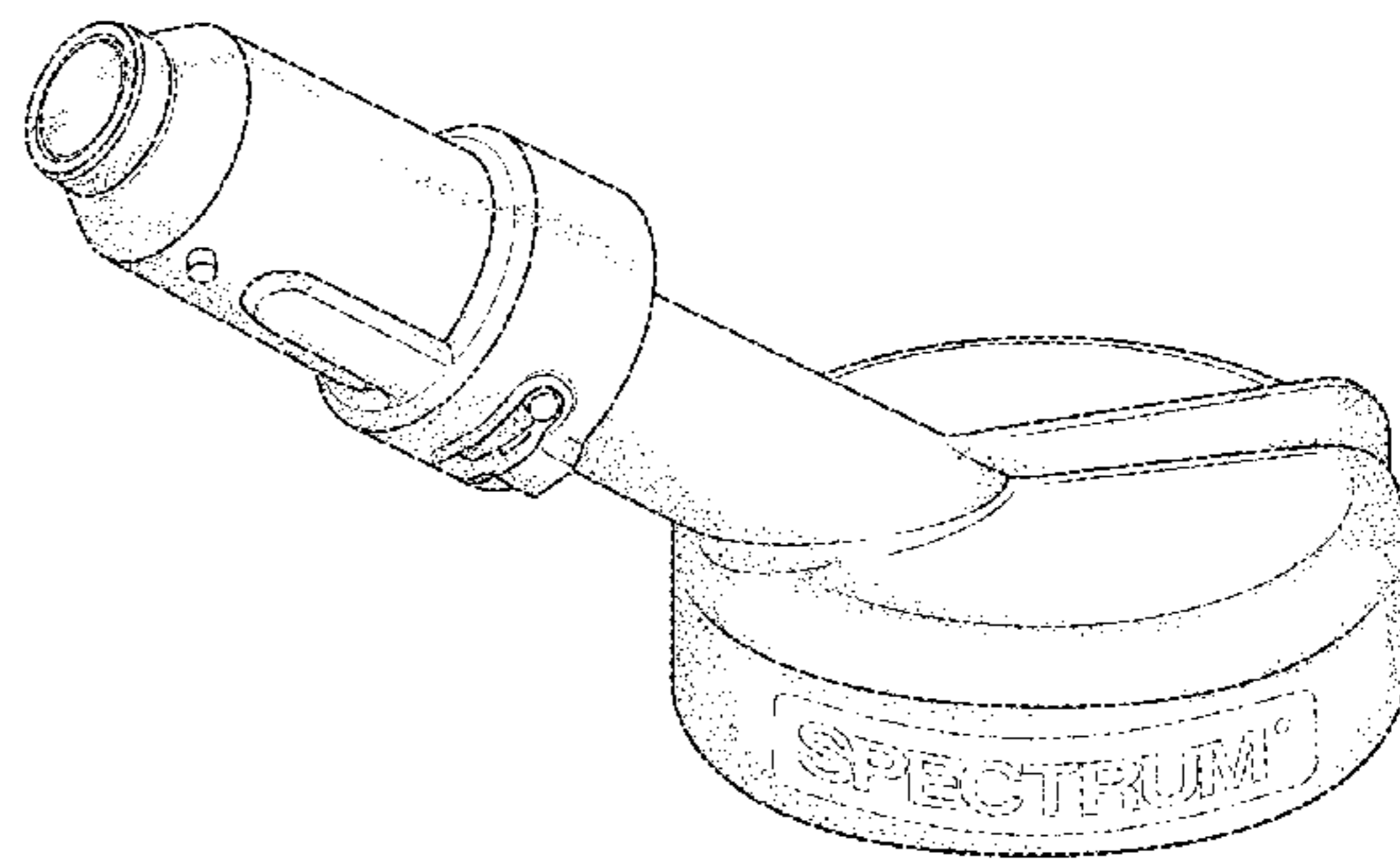
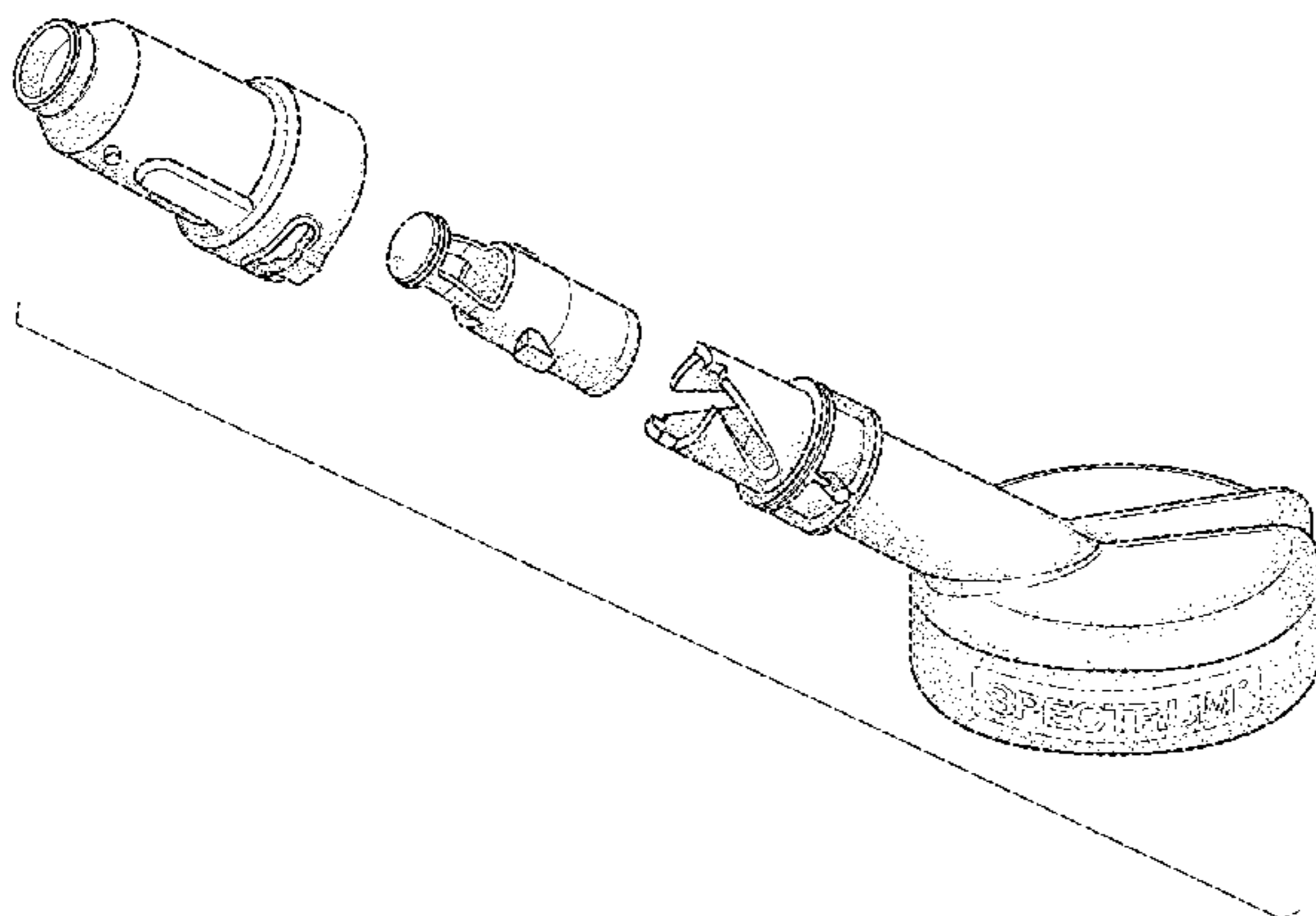

US D687,923 S

U.S. PATENT DOCUMENTS					
1,600,262 A	9/1926	Wickham	5,271,528 A	12/1993	Chien
1,610,283 A	12/1926	Hill	5,273,134 A	12/1993	Hegemier et al.
1,687,395 A	10/1928	Shew	5,274,335 A	12/1993	Wang et al.
1,688,279 A	10/1928	Locke	5,314,613 A	5/1994	Russo
1,864,195 A	6/1932	Hall	5,317,252 A	5/1994	Kranbuehl
2,227,646 A	1/1941	Hillman	5,318,152 A	6/1994	Ehlert
2,335,557 A	11/1943	Winther	5,328,275 A	7/1994	Winn et al.
2,340,455 A	2/1944	Davis	5,330,636 A	7/1994	Reichert
2,376,623 A	5/1945	Romberg	5,332,064 A	7/1994	Liu
2,397,597 A	4/1946	Dunkle	5,334,941 A	8/1994	King
2,439,709 A	4/1948	Ashbury	5,381,874 A	1/1995	Hadank et al.
2,589,081 A	3/1952	Hertz	5,382,942 A	1/1995	Raffa et al.
2,608,993 A	9/1952	Andrews	D358,097 S	5/1995	Leibowitz
2,703,628 A	3/1955	Pompeo et al.	D358,548 S	5/1995	Platte
2,774,621 A	12/1956	Kilbourne, Jr.	5,457,396 A	10/1995	Mori et al.
2,930,432 A	3/1960	Engstrom	5,499,902 A	3/1996	Rockwood
2,950,943 A	8/1960	Forrest	5,504,573 A	4/1996	Cheiky-Zelina
2,995,213 A	8/1961	Gross	5,521,515 A	5/1996	Campbell
3,123,095 A	3/1964	Kohler	5,540,086 A	7/1996	Park et al.
3,193,990 A	7/1965	Smith	5,542,499 A	8/1996	Westermeyer
3,233,173 A	2/1966	Lees et al.	5,548,217 A	8/1996	Gibson et al.
D205,166 S	6/1966	Price	5,568,842 A	10/1996	Otani
3,323,291 A	6/1967	Kern	5,596,266 A	1/1997	Mori et al.
3,338,262 A	8/1967	Chopelin	5,604,441 A	2/1997	Freese
3,447,562 A	6/1969	Hoffman	5,614,830 A	3/1997	Dickert et al.
D217,665 S	5/1970	Self	5,634,531 A	6/1997	Graf et al.
D217,666 S	5/1970	Self	5,647,735 A	7/1997	Rockwood
D217,667 S	5/1970	Self	5,656,767 A	8/1997	Garvey, III et al.
3,952,566 A	4/1976	Jacobson	5,671,825 A	9/1997	Wong et al.
4,018,579 A	4/1977	Hofmann	5,674,401 A	10/1997	Dickert et al.
4,047,814 A	9/1977	Westcott	5,702,592 A	12/1997	Suri et al.
4,058,766 A	11/1977	Vogel et al.	5,754,055 A	5/1998	McAdoo
4,064,455 A	12/1977	Hopkins et al.	5,779,005 A	7/1998	Jones, Jr. et al.
4,105,092 A	8/1978	Zeidler et al.	5,789,665 A	8/1998	Voelker et al.
4,227,419 A	10/1980	Park	5,806,630 A	9/1998	Bernal
4,312,424 A	1/1982	Taylor et al.	5,816,212 A	10/1998	Lindquist et al.
4,345,668 A	8/1982	Gaunt	5,824,889 A	10/1998	Park et al.
4,423,371 A	12/1983	Senturia et al.	5,826,986 A	10/1998	Adkins et al.
4,445,168 A	4/1984	Petryszyn	5,858,070 A	1/1999	Halm et al.
4,466,508 A	8/1984	Busch	5,878,842 A	3/1999	Rake
4,503,383 A	3/1985	Agar	5,884,802 A	3/1999	Leibowitz
D279,549 S	7/1985	Elmburg	6,028,433 A	2/2000	Cheiky-Zelina et al.
4,527,661 A	7/1985	Johnstone et al.	6,077,330 A	6/2000	Sabelstrom
4,591,024 A	5/1986	Erickson	6,113,676 A	9/2000	Kumpulainen
4,629,334 A	12/1986	Hochstein	D433,635 S *	11/2000	Chrisco et al. D9/527
4,646,070 A	2/1987	Yasuhara	D435,451 S *	12/2000	Giugiaro D9/528
4,681,189 A	7/1987	Krisiloff	6,192,025 B1	2/2001	Chen
4,689,553 A	8/1987	Haddox	6,204,656 B1	3/2001	Cheiky-Zelina et al.
4,733,556 A	3/1988	Meitzler et al.	6,223,589 B1	5/2001	Dickert et al.
4,735,286 A	4/1988	Miki et al.	6,250,152 B1	6/2001	Klein et al.
4,738,336 A	4/1988	Smith et al.	6,253,601 B1	7/2001	Wang et al.
D302,888 S	8/1989	Jung	6,273,031 B1	8/2001	Verdegan et al.
4,990,057 A	2/1991	Rollins	6,277,173 B1	8/2001	Sadakata et al.
5,025,222 A	6/1991	Scott et al.	6,278,282 B1	8/2001	Marszalek
5,039,425 A	8/1991	Caris et al.	6,368,411 B2	4/2002	Roberson, Jr. et al.
5,042,618 A	8/1991	Switalski et al.	6,443,006 B1	9/2002	Degrave
5,045,798 A	9/1991	Hendrick	6,447,573 B1	9/2002	Rake
5,060,760 A	10/1991	Long et al.	6,449,580 B1	9/2002	Bardetsky et al.
5,071,527 A	12/1991	Kauffman	6,459,995 B1	10/2002	Collister
5,072,190 A	12/1991	Martin	6,460,656 B1	10/2002	Jones, Jr. et al.
5,080,195 A	1/1992	Mizumoto et al.	6,509,749 B1	1/2003	Buelna et al.
D324,495 S *	3/1992	Warrington D9/528	6,513,368 B2	2/2003	Bondarowicz et al.
5,101,936 A	4/1992	Paredes et al.	6,519,034 B1	2/2003	Engler et al.
5,103,181 A	4/1992	Gaisford et al.	6,535,001 B1	3/2003	Wang
5,125,480 A	6/1992	Gregory et al.	6,551,055 B2	4/2003	Rockwood
D333,177 S	2/1993	Poirier	6,553,812 B2	4/2003	Park et al.
5,196,898 A	3/1993	Tamura et al.	6,557,396 B2	5/2003	Ismail et al.
5,197,569 A	3/1993	Roessler et al.	6,564,126 B1	5/2003	Lin et al.
5,200,027 A	4/1993	Lee et al.	6,568,919 B1	5/2003	Fletcher et al.
5,203,680 A	4/1993	Waldrop	D485,189 S	1/2004	Montalbano et al.
D336,509 S	6/1993	Safford et al.	6,851,676 B2	2/2005	Martins et al.
D336,679 S	6/1993	Safford et al.	6,932,856 B2	8/2005	Rake
5,224,051 A	6/1993	Johnson	7,017,712 B1	3/2006	Rake et al.
D338,158 S	8/1993	Poirier	D527,639 S	9/2006	Voss et al.
5,249,455 A	10/1993	Cox	D528,425 S	9/2006	Van Dorin et al.
5,260,665 A	11/1993	Goldberg et al.	7,140,468 B2	11/2006	Rake et al.
5,262,732 A	11/1993	Dickert et al.	D573,885 S	7/2008	Considine et al.
5,269,175 A	12/1993	Chmiel et al.	D581,481 S *	11/2008	Edwards D23/211
			D589,597 S	3/2009	Bloch et al.

D589,807 S	4/2009	Gundrum et al.	
D589,808 S	4/2009	Gundrum et al.	
D589,809 S	4/2009	Gundrum et al.	
7,541,004 B2	6/2009	Niksa et al.	
7,862,875 B2	1/2011	Bloch et al.	
8,096,164 B2	1/2012	Koehler	
D654,796 S *	2/2012	Wurth et al.	D9/528
D658,062 S *	4/2012	Kim et al.	D9/528
8,147,683 B2	4/2012	Wilson	
8,147,684 B2	4/2012	Wilson	

FOREIGN PATENT DOCUMENTS

CA	122622	4/2009
CA	127724	5/2009
CA	127725	5/2009
CA	127726	5/2009
DE	37325	3/1968
GB	121092	12/1918
JP	2-308916	12/1990
JP	411132304	5/1999

OTHER PUBLICATIONS

Iotech Catalog, p. 65, Jan. 1995.
 "Model 958PF On-Line Ferrograph", *Foxboro Analytical*, (no month available) 1980, 4 pgs.
 958F Series On-Line Ferrograph Installation and Operation, The Foxboro Company, (no month available) 1980, 6 pgs.
 "Journal Reprints", The British Institute of Non-Destructive Testing, M.H. Jones and A.R. Massoudi, *Insight*, vol. 37 No. 8, Aug., 1995. pp. 606-610.

"Basics of Measuring the Dielectric Properties of Materials", Hewlett Packard, (no month available) 1992, No. 1217-1.
 "The Nist 60-Millimeter Diameter Cylindrical Cavity Resonator: Performance Evaluation for Permittivity Measurements", Eric J. Vanzura, Richard G. Geyer and Michael D. Janezic, Aug. 1993, National Institute of Standards and Technology Technical Note.
 Measuring Moisture in Liquids; A New Method, *Sensors*, Dec. 1996 pp. 42-47.
 Sensor Mediated in Situ Measurement of Moisture in Organic Liquids, Phys-Chem Scientific Corp. sales literature, date unknown.
 "Hydraulic and Lubrication Systems Solutions: Water Sensor—An Essential tool for fluid condition monitoring" Pall Corporation sales literature, date unknown.
 Environmental Solutions for the Military: Pall Portable Fluid Purifier, not dated; Pall Corporation web site address: www.pall.com/environ/military/solutions/products/purifier.html.
 Pall Water Sensor: An essential tool for fluid condition monitoring; Pall Corporation sales literature, date unknown.
 "Advancement of Predict/DLI Industrial Sensors", M.A. Cheiky-Zelina, R.W. Brown and D.E. Schuele, Department of Physics, Case Western Reserve University, Mar. 1997.
 Filtration Products, Solutions for Tomorrow's Challenges, Trico sales literature, 7 pages, date unknown.
 Mobile Filtration System, Oil Service Products sales literature, 1 page, date unknown.
 Mobile Filtration Systems, Schroeder Industries LLC, 2 pages, date unknown.

* cited by examiner

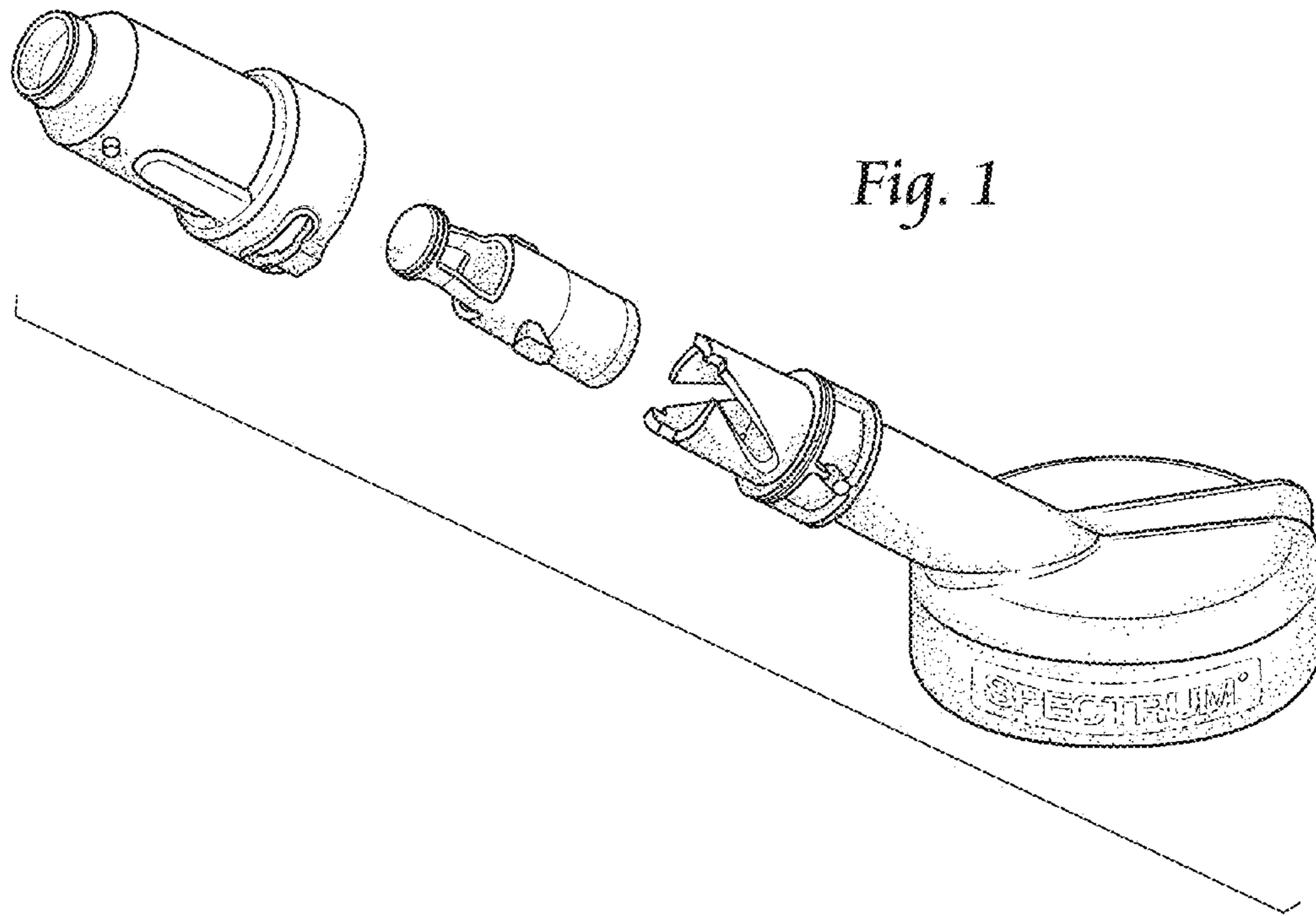

Fig. 1

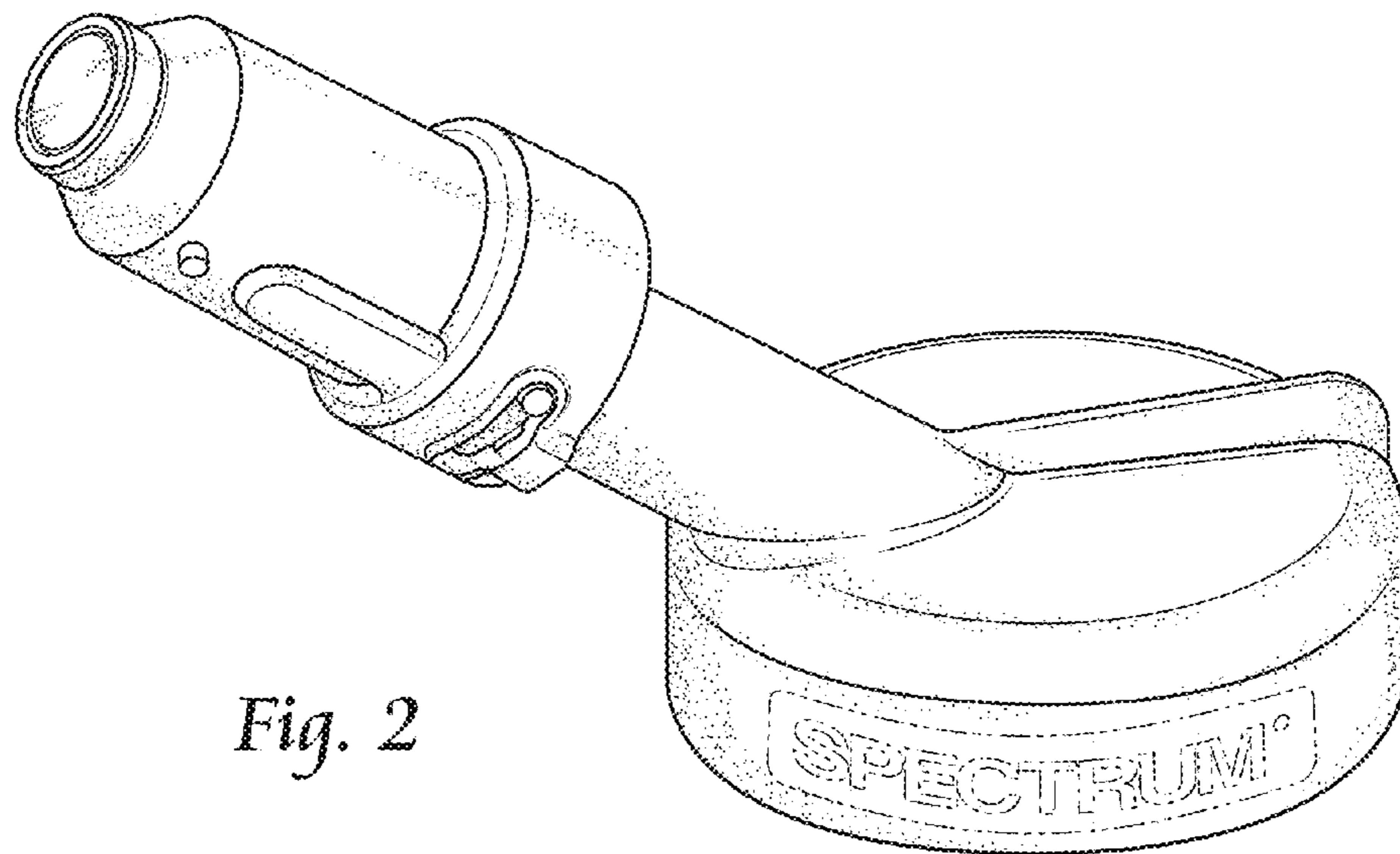

Fig. 2

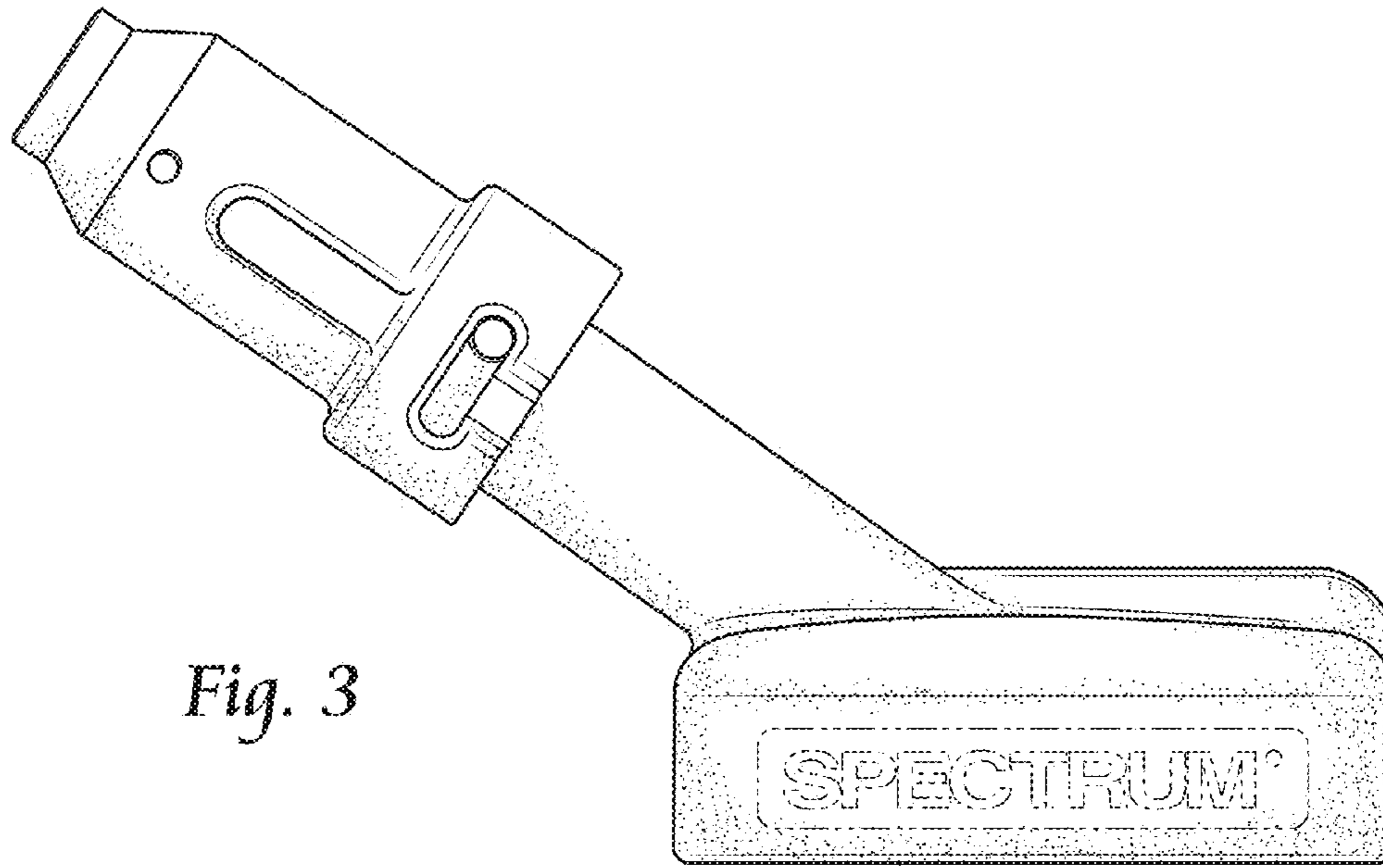

Fig. 3

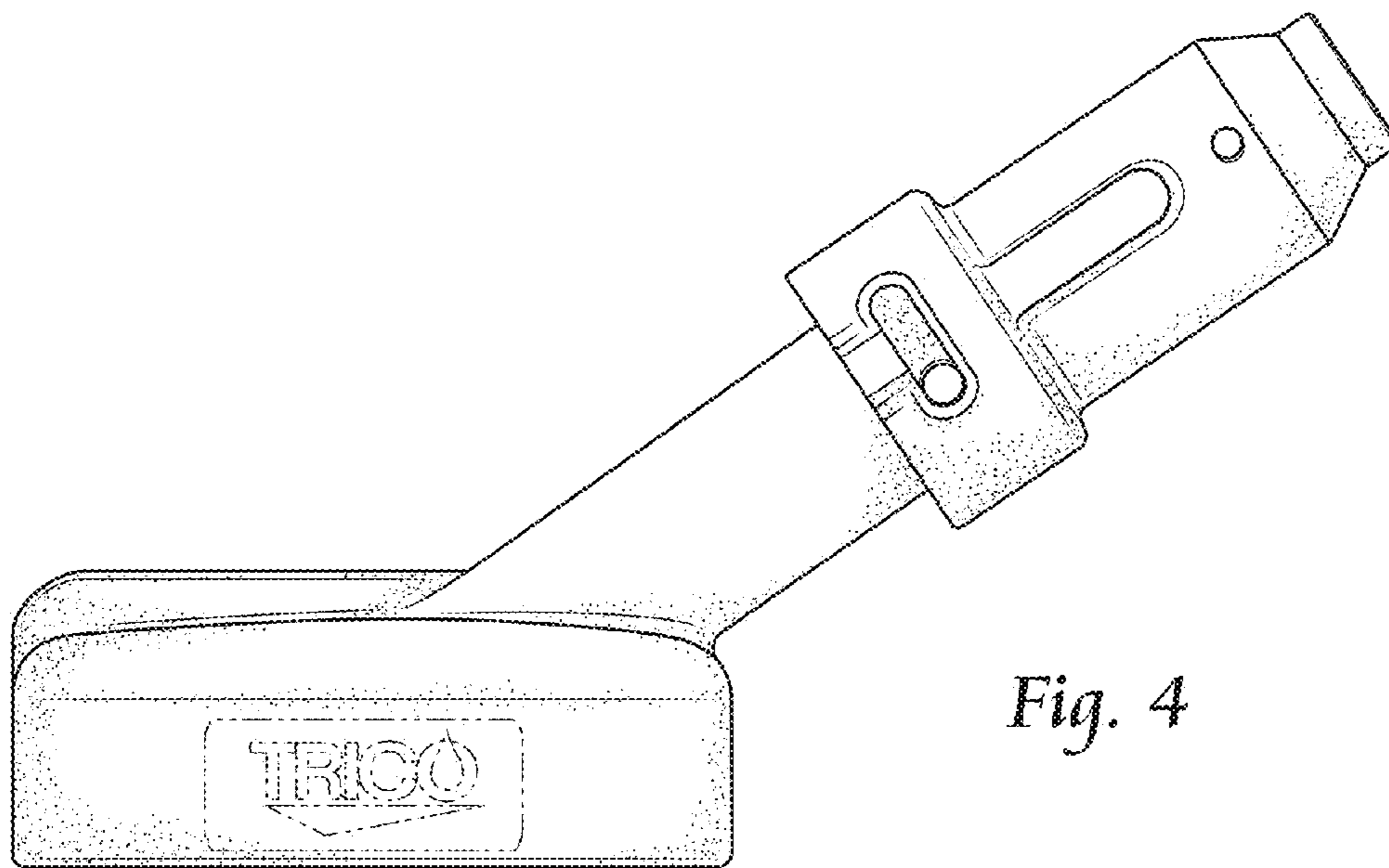

Fig. 4

Fig. 5

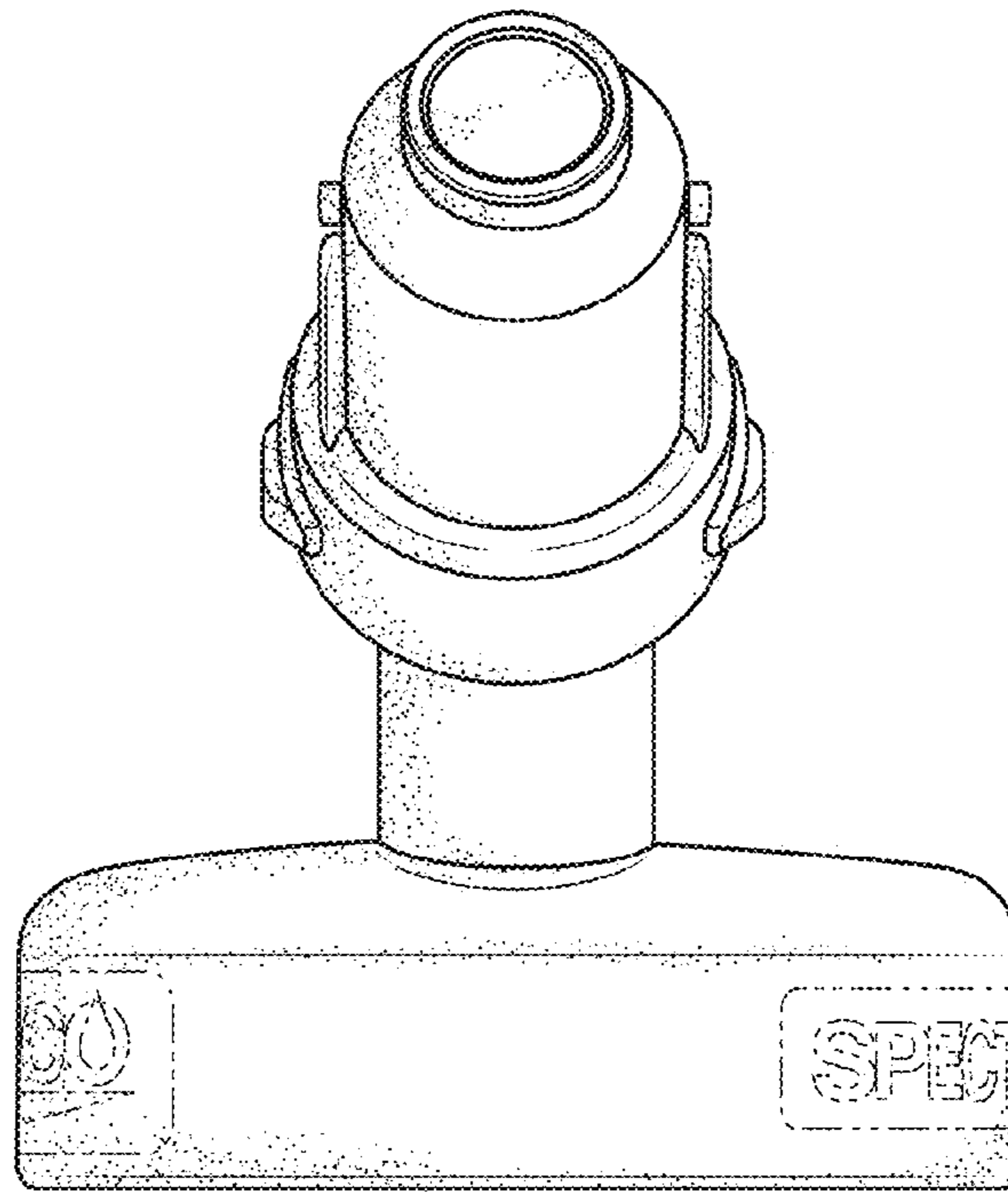
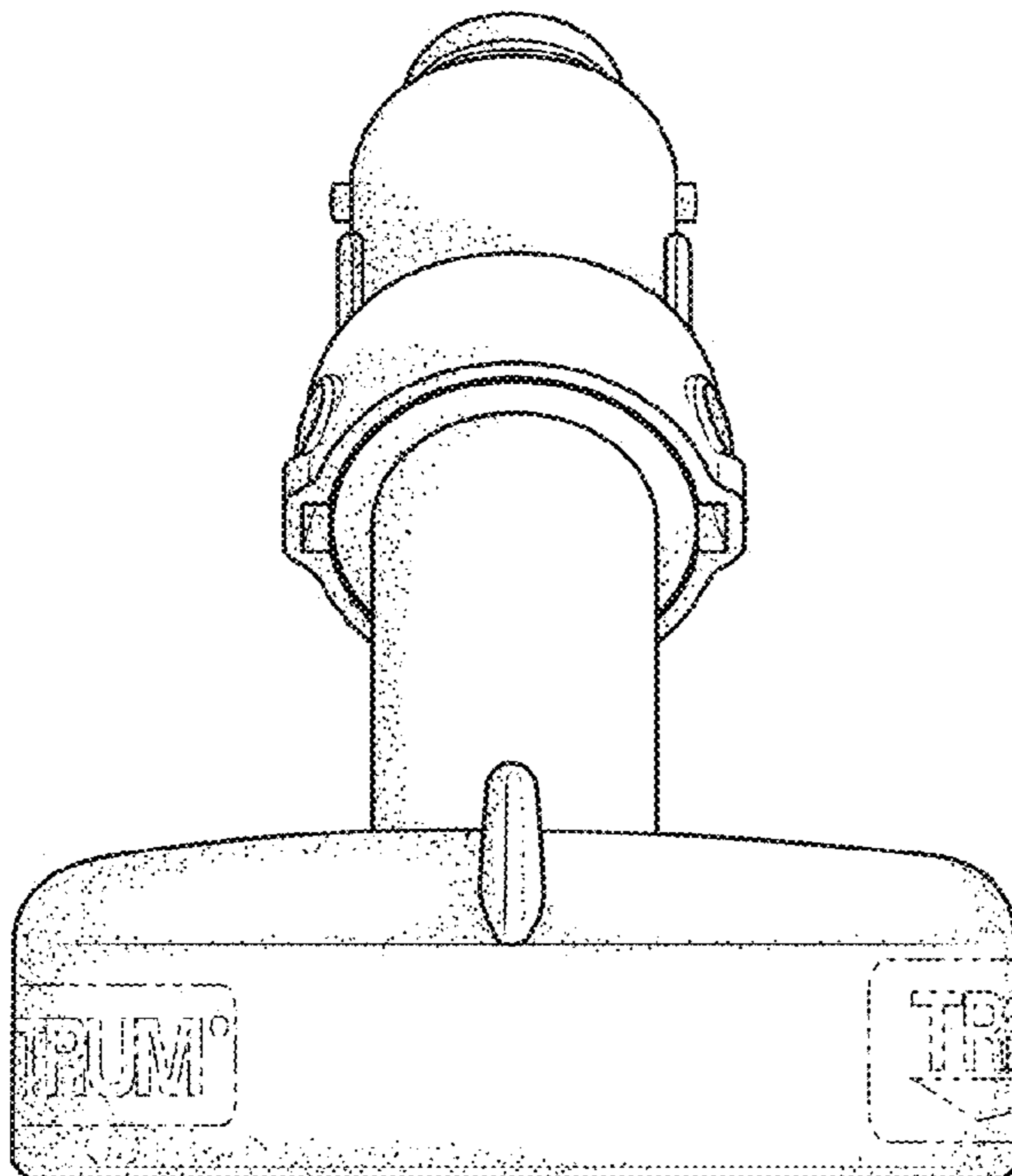

Fig. 6



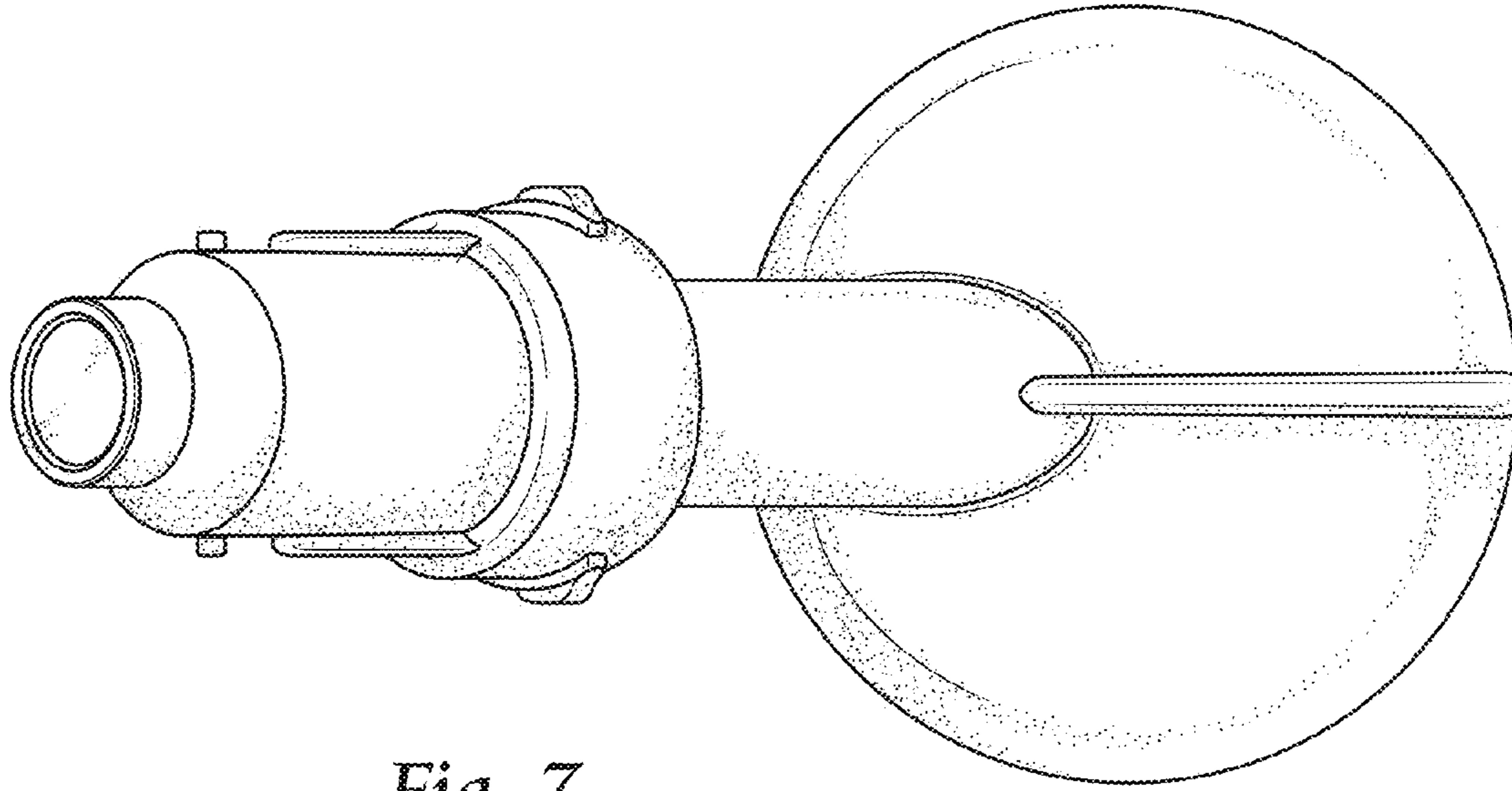

Fig. 7

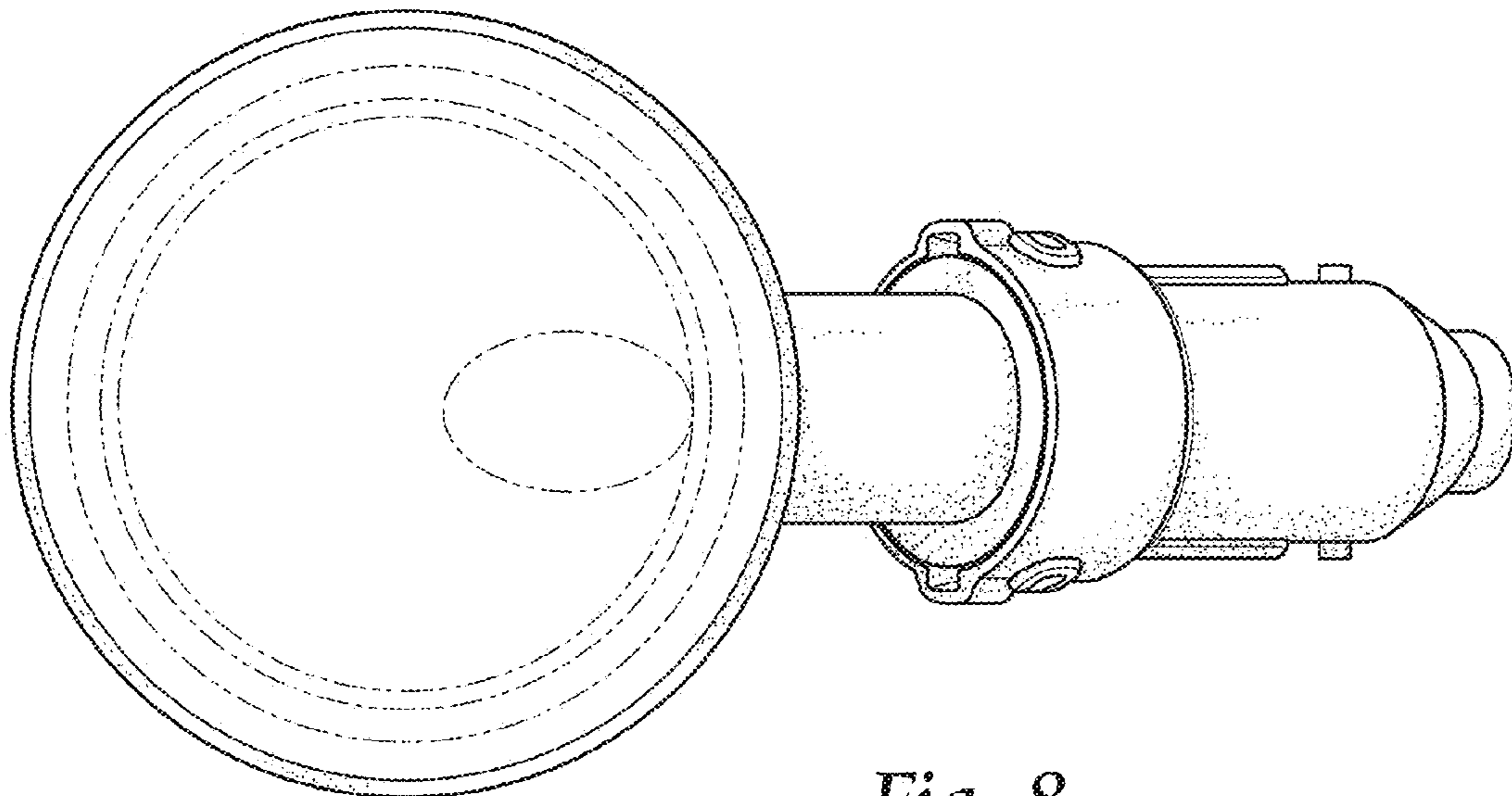

Fig. 8