



US00D687371S

(12) **United States Design Patent**
Hayashi

(10) **Patent No.:** **US D687,371 S**
(45) **Date of Patent:** **** Aug. 6, 2013**

(54) **TREAD PORTION OF AN AUTOMOBILE TIRE**

Primary Examiner — George D Kirschbaum

(74) *Attorney, Agent, or Firm* — Sughrue Mion, PLLC

(75) Inventor: **Naohiro Hayashi**, Tokyo (JP)

(73) Assignee: **Bridgestone Corporation**, Tokyo (JP)

(**) Term: **14 Years**

(21) Appl. No.: **29/412,737**

(22) Filed: **Feb. 7, 2012**

(30) **Foreign Application Priority Data**

Aug. 8, 2011 (JP) 2011-018147

(51) **LOC (9) Cl.** **12-15**

(52) **U.S. Cl.**
USPC **D12/598**

(58) **Field of Classification Search**
USPC D12/568-603; 152/209.1-209.28
See application file for complete search history.

(56) **References Cited**

U.S. PATENT DOCUMENTS

D619,086 S * 7/2010 Reim et al. D12/598
D646,217 S * 10/2011 Muto D12/589
D646,218 S * 10/2011 Muto D12/589
2011/0303333 A1 * 12/2011 Muto 152/209.25

* cited by examiner

(57) **CLAIM**

The ornamental design for a tread portion of an automobile tire, as shown and described.

DESCRIPTION

FIG. 1 is a perspective view of the tread portion of an automobile tire according to my design;
FIG. 2 is a front view thereof;
FIG. 3 is a plane view thereof;
FIG. 4 is a right side view thereof;
FIG. 5 is a fragmentary enlarged view showing the details of the tread portion thereof;
FIG. 6 is an end view taken along line 6-6 in FIG. 5 thereof; and,
FIG. 7 is an end view taken along line 7-7 in FIG. 5 thereof.
Broken lines in the drawing figures are used to show portions of the tire that are not being claimed, and thus form no part of the claimed design.

1 Claim, 7 Drawing Sheets

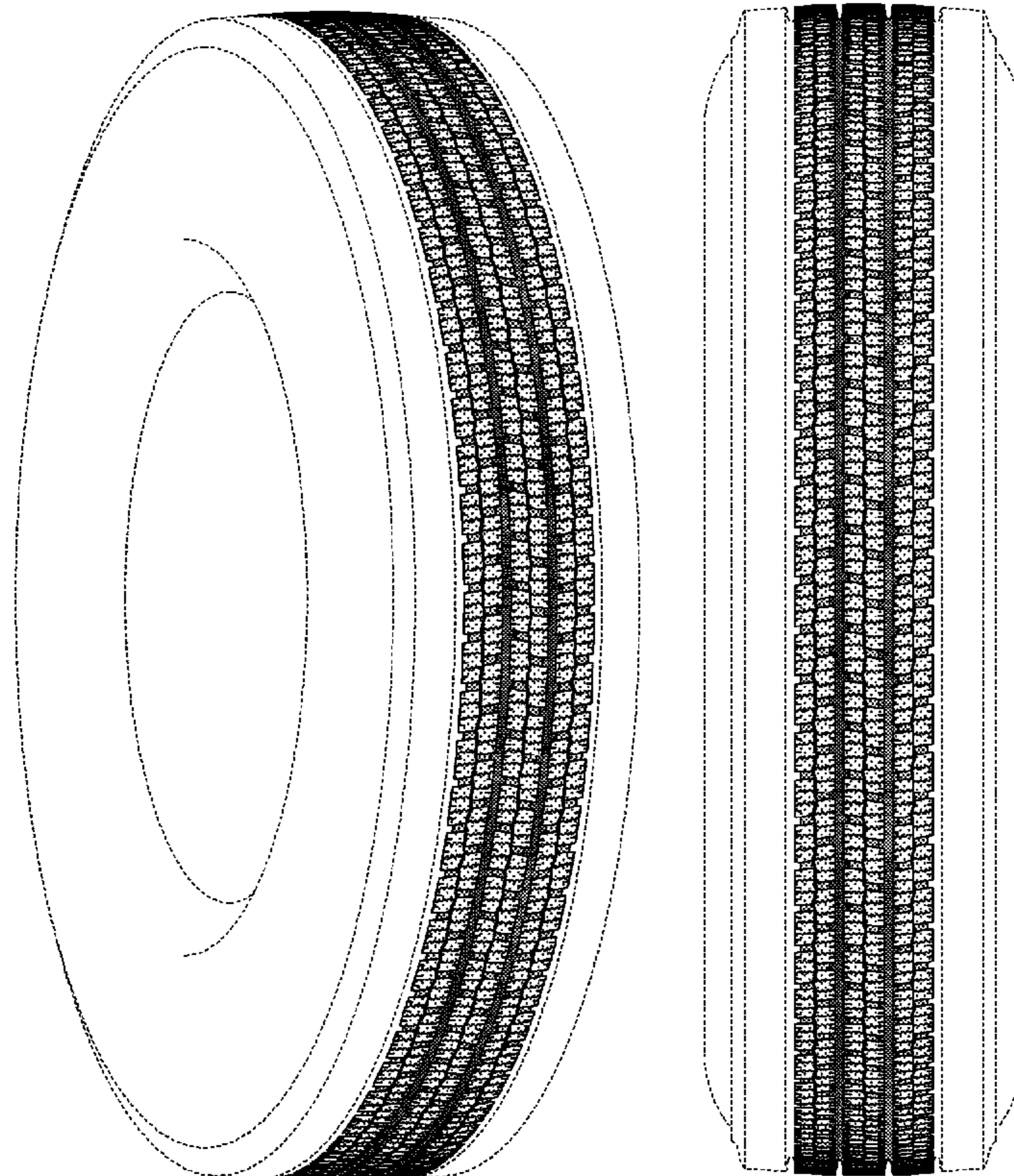

FIG. 1

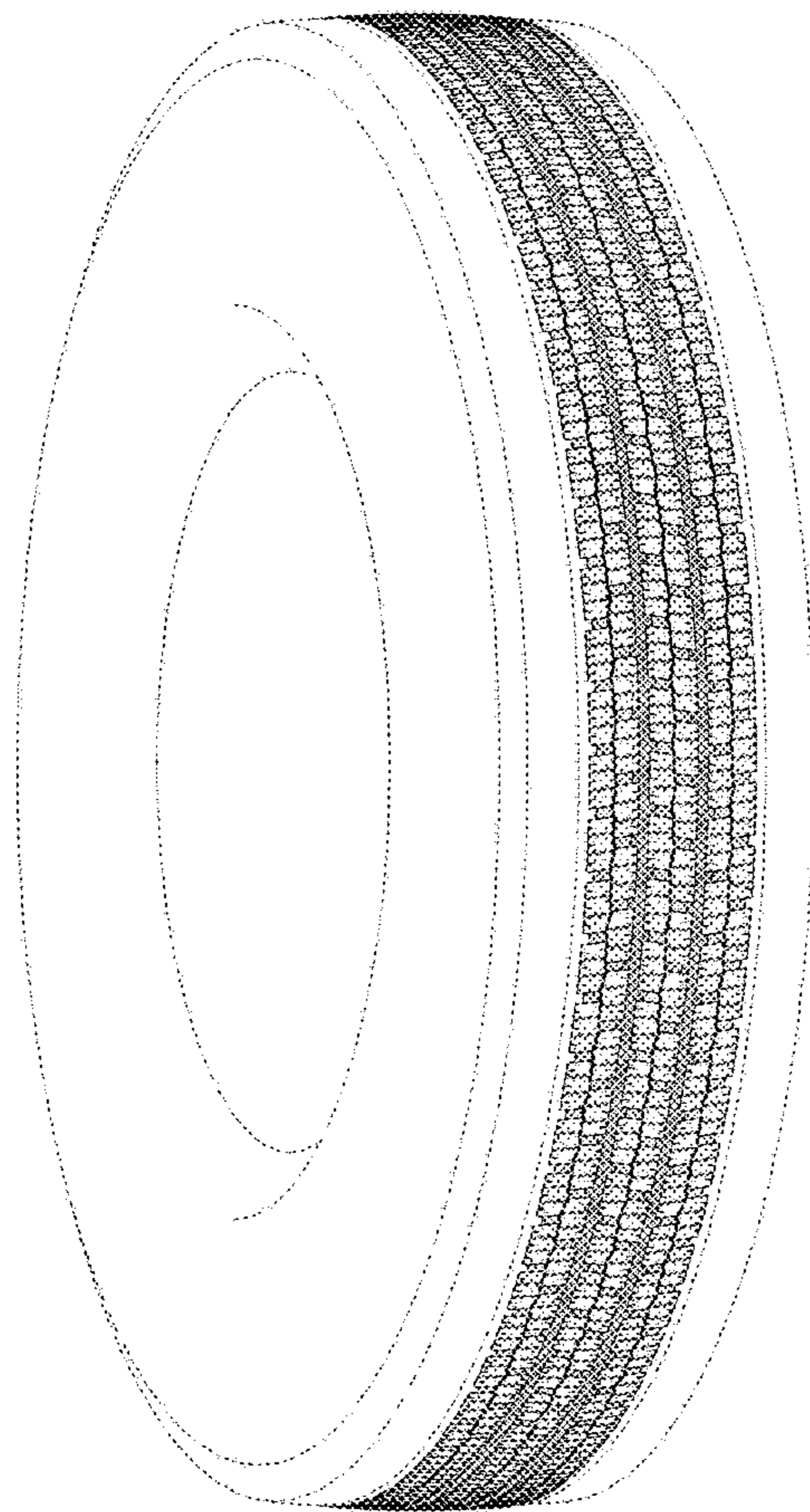

FIG. 2

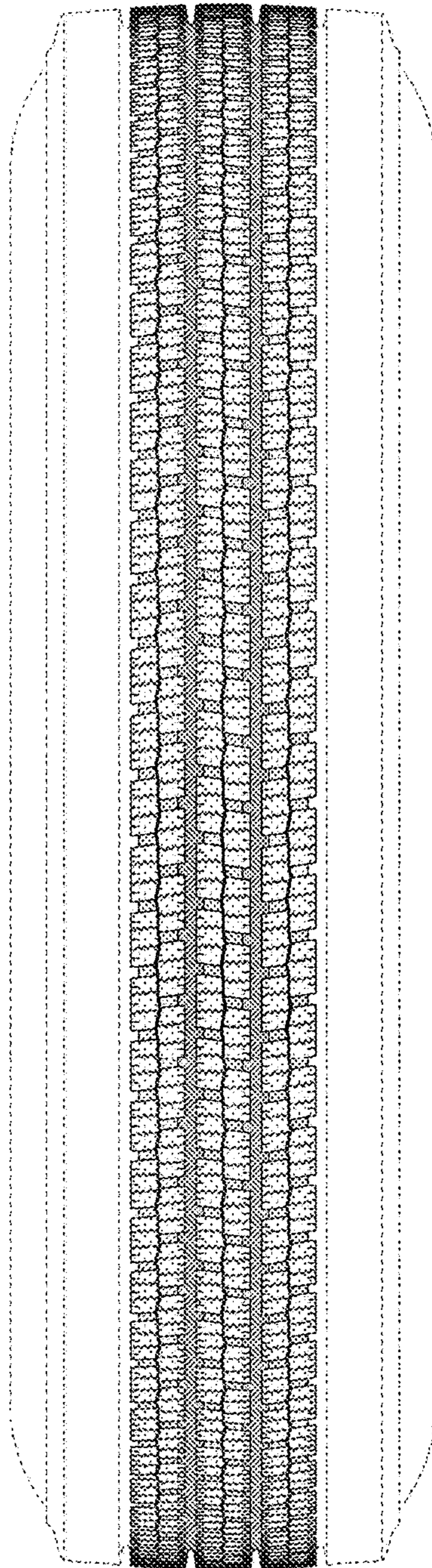

FIG. 3

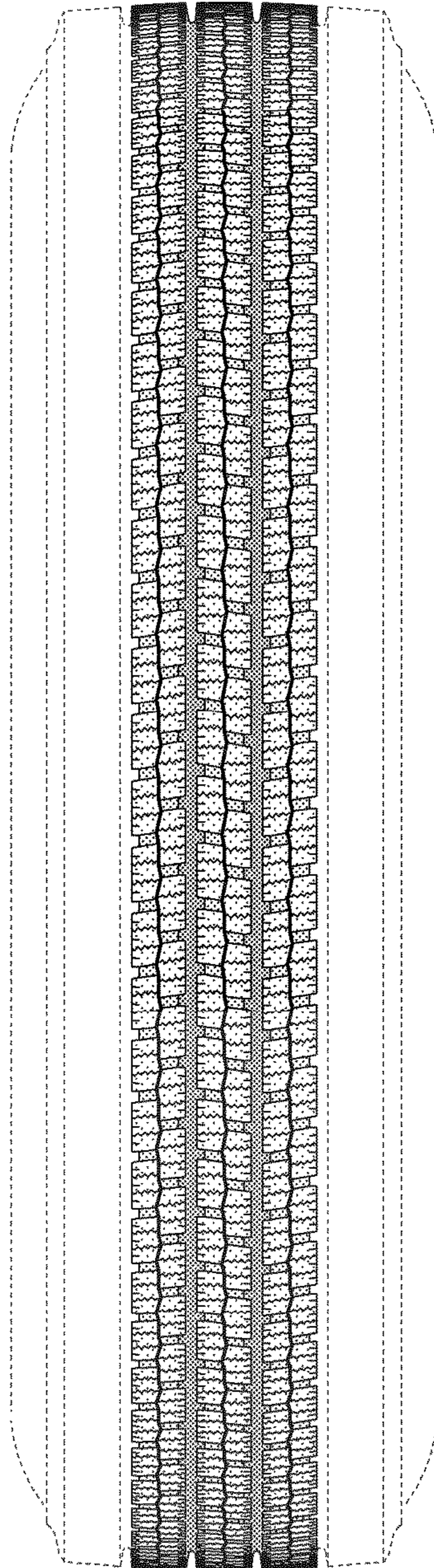

FIG. 4

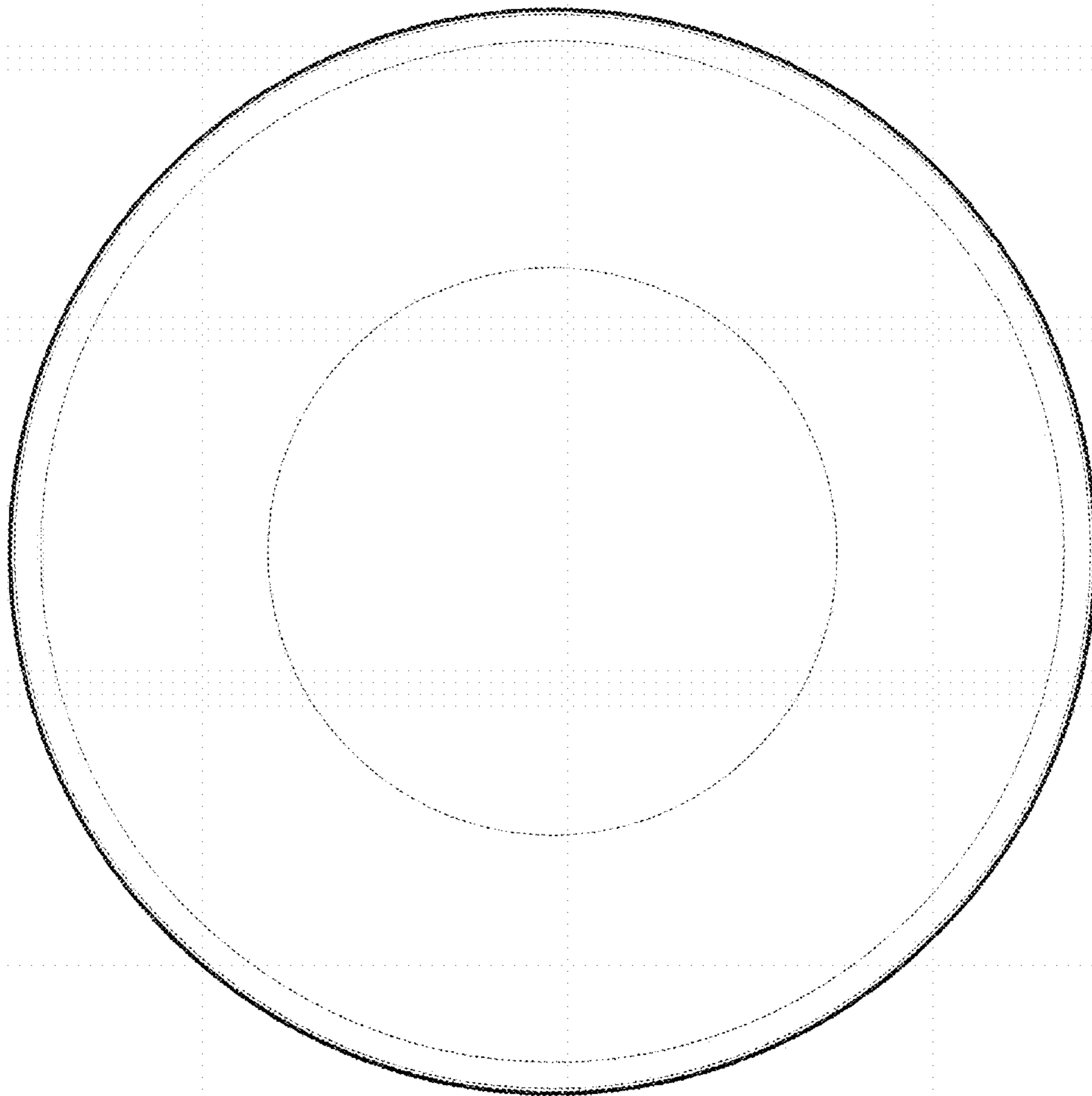

FIG. 5

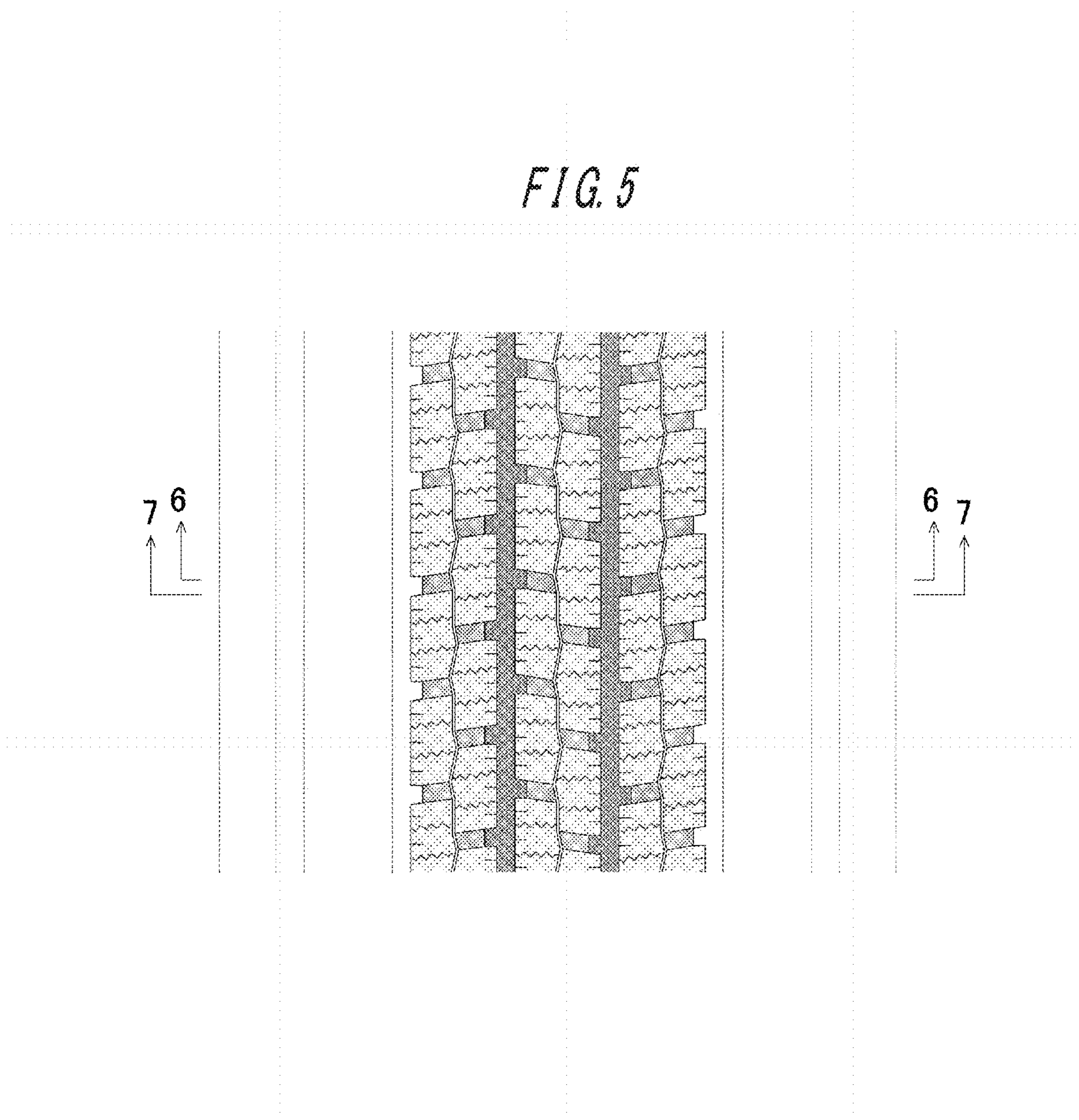

FIG. 6

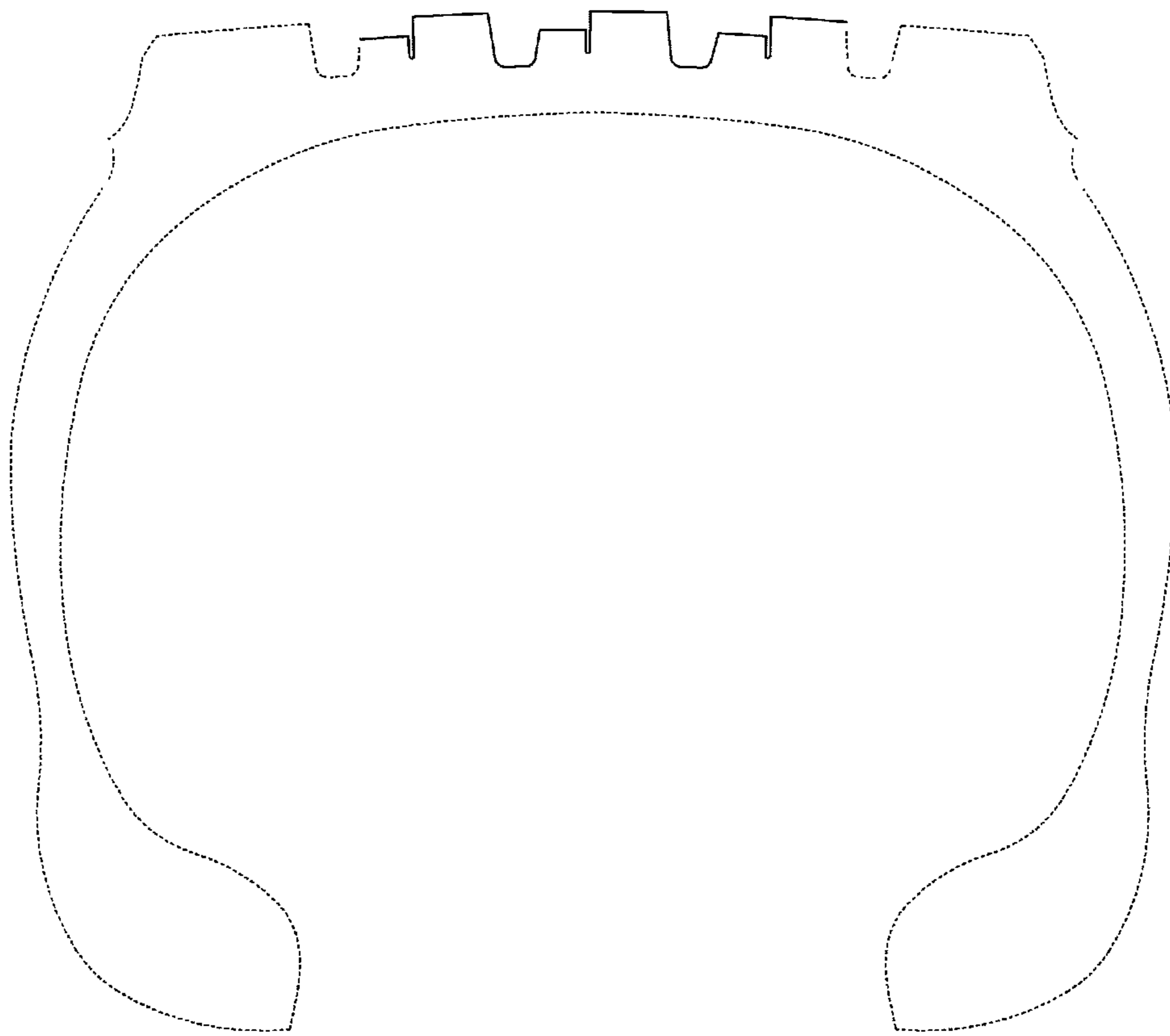

FIG. 7

