



US00D687322S

(12) **United States Design Patent**
Ferrari et al.

(10) **Patent No.:** **US D687,322 S**
(45) **Date of Patent:** **** Aug. 6, 2013**

(54) **COORDINATE ACQUISITION MEMBER OF A PORTABLE COORDINATE MEASUREMENT MACHINE**

5,084,981 A 2/1992 McMurtry et al.
5,088,337 A 2/1992 Bennett
5,148,377 A 9/1992 McDonald

(Continued)

(75) Inventors: **Paul Ferrari**, Carlsbad, CA (US);
Thibault Duportal, Prunay-Cassereau (FR); **Elie Shammas**, San Diego, CA (US); **Jerry Gerent**, Vista, CA (US); **Dongmei Hong**, San Diego, CA (US); **Denny Roux**, Landes le Gaulois (FR)

FOREIGN PATENT DOCUMENTS

DE 4345091 7/1995
DE 10112977 11/2002

(Continued)

Primary Examiner — Antoine D Davis

(73) Assignee: **Hexagon Metrology AB**, Nacka Strand (SE)

(74) *Attorney, Agent, or Firm* — Knobbe, Martens, Olson & Bear, LLP.

(**) Term: **14 Years**

(57) **CLAIM**

The ornamental design for a coordinate acquisition member of a portable coordinate measurement machine, as shown and described.

(21) Appl. No.: **29/416,714**

DESCRIPTION

(22) Filed: **Mar. 26, 2012**

Related U.S. Application Data

(62) Division of application No. 29/396,902, filed on Jul. 8, 2011, now Pat. No. Des. 659,035, which is a division of application No. 29/358,527, filed on Mar. 29, 2010, now Pat. No. Des. 643,319.

(51) **LOC (9) Cl.** **10-04**

(52) **U.S. Cl.**
USPC **D10/63; D15/199**

(58) **Field of Classification Search**
USPC D10/63; D15/199; 33/503–505, 558, 33/502, 561; 74/490.01–490.06; 319/560; 700/245, 262, 195, 80; 702/150–156, 94, 702/95, 167–169

See application file for complete search history.

(56) **References Cited**

U.S. PATENT DOCUMENTS

4,492,036 A 1/1985 Beckwith
4,972,090 A 11/1990 Eaton

FIG. 1 is a perspective view of a coordinate acquisition member of a portable coordinate measurement machine showing our new design in accordance with a first embodiment of the invention;

FIG. 2 is a front view of the coordinate acquisition member of a portable coordinate measurement machine as shown in FIG. 1;

FIG. 3 is a rear view of the coordinate acquisition member of a portable coordinate measurement machine as shown in FIG. 1;

FIG. 4 is a left side view of the coordinate acquisition member of a portable coordinate measurement machine as shown in FIG. 1;

FIG. 5 is a right side view of the coordinate acquisition member of a portable coordinate measurement machine as shown in FIG. 1;

FIG. 6 is a top view of the coordinate acquisition member of a portable coordinate measurement machine as shown in FIG. 1; and,

FIG. 7 is a bottom view of the coordinate acquisition member of a portable coordinate measurement machine as shown in FIG. 1.

1 Claim, 4 Drawing Sheets

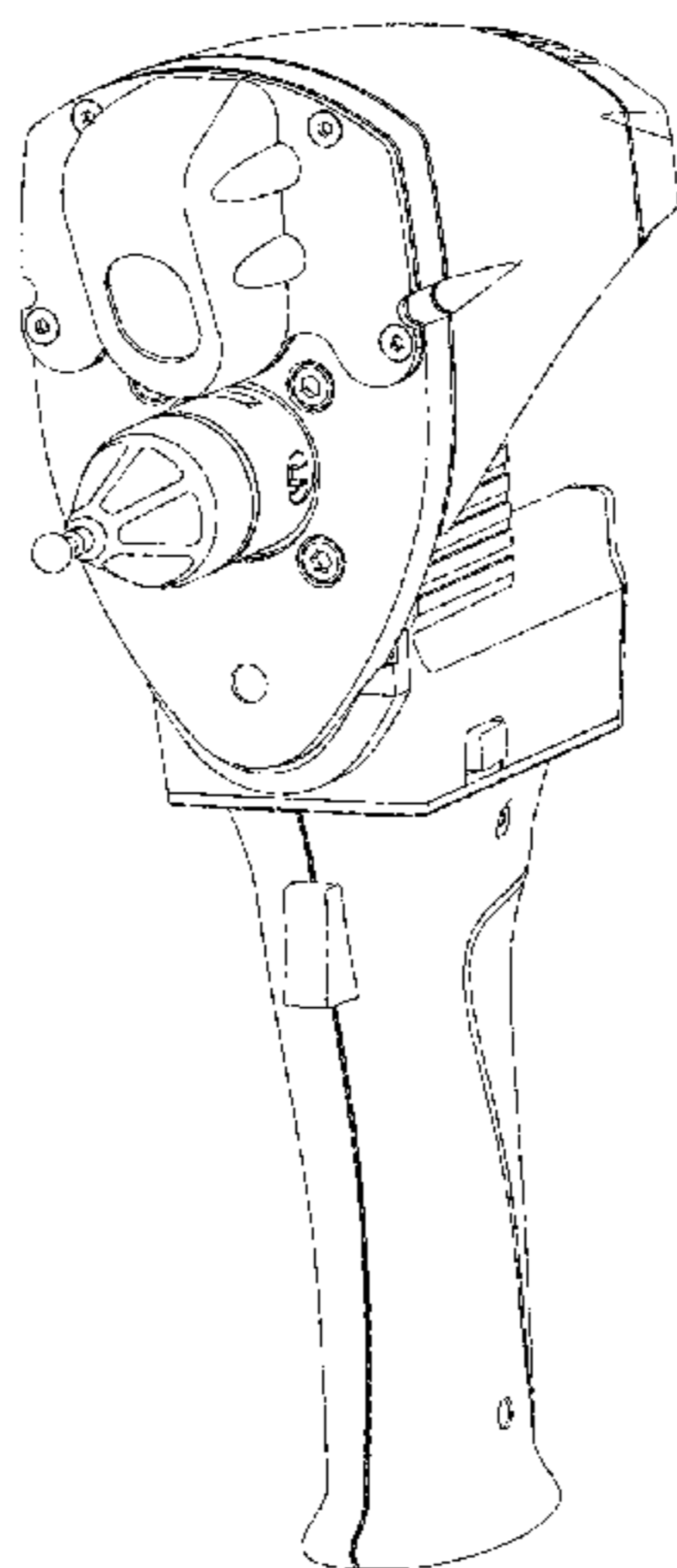

US D687,322 S

U.S. PATENT DOCUMENTS			FOREIGN PATENT DOCUMENTS		
5,187,874 A	2/1993	Takahashi et al.	7,051,450 B2	5/2006	Raab et al.
5,189,797 A	3/1993	Granger	7,073,271 B2	7/2006	Raab et al.
5,396,712 A	3/1995	Herzog	7,096,077 B2	8/2006	Price et al.
5,408,754 A	4/1995	Raab	7,152,456 B2	12/2006	Eaton
5,412,880 A	5/1995	Raab	7,174,651 B2	2/2007	Raab et al.
5,505,003 A	4/1996	Evans et al.	7,269,910 B2	9/2007	Raab et al.
5,510,977 A	4/1996	Raab	7,296,364 B2	11/2007	Seitz et al.
5,521,847 A	5/1996	Ostrowski et al.	7,296,979 B2	11/2007	Raab et al.
5,526,576 A	6/1996	Fuchs et al.	7,372,581 B2	5/2008	Raab et al.
5,528,505 A	6/1996	Granger et al.	7,395,606 B2	7/2008	Crampton
D377,932 S	2/1997	Schena et al.	7,441,341 B2	10/2008	Eaton
5,611,147 A	3/1997	Raab	7,525,276 B2	4/2009	Eaton
5,615,489 A	4/1997	Breyer et al.	7,546,689 B2	6/2009	Ferrari et al.
5,757,499 A	5/1998	Eaton	7,568,293 B2	8/2009	Ferrari
5,768,792 A	6/1998	Raab	7,578,069 B2	8/2009	Eaton
5,794,356 A	8/1998	Raab	D599,226 S	9/2009	Gerent et al.
5,822,450 A	10/1998	Arakawa et al.	7,624,510 B2	12/2009	Ferrari
5,829,148 A	11/1998	Eaton	D607,350 S	1/2010	Cooduvalli et al.
5,978,748 A	11/1999	Raab	7,640,674 B2	1/2010	Ferrari et al.
5,991,704 A	11/1999	Rekar et al.	7,676,945 B2	3/2010	Prestidge et al.
6,134,506 A	10/2000	Rosenberg et al.	7,693,325 B2	4/2010	Pulla et al.
6,161,079 A	12/2000	Zink et al.	7,743,524 B2	6/2010	Eaton et al.
6,166,811 A	12/2000	Long et al.	7,774,949 B2	8/2010	Ferrari
6,219,928 B1	4/2001	Raab et al.	7,779,548 B2	8/2010	Ferrari
6,366,831 B1	4/2002	Raab	7,784,194 B2	8/2010	Raab et al.
6,487,896 B1	12/2002	Dall'Aglio	7,805,854 B2	10/2010	Eaton
6,526,670 B1	3/2003	Carli	7,908,757 B2	3/2011	Ferrari
D472,824 S	4/2003	Raab et al.	7,984,558 B2	7/2011	Ferrari
6,598,306 B2	7/2003	Eaton	D643,319 S	8/2011	Ferrari et al.
6,611,346 B2	8/2003	Granger	8,015,721 B2	9/2011	Eaton et al.
6,611,617 B1	8/2003	Crampton	8,099,877 B2	1/2012	Champ
D479,544 S	9/2003	Raab et al.	8,104,189 B2	1/2012	Tait
6,618,496 B1	9/2003	Tassakos et al.	8,112,896 B2	2/2012	Ferrari et al.
6,668,466 B1	12/2003	Bieg et al.	8,122,610 B2	2/2012	Tait et al.
D490,831 S	6/2004	Raab et al.	D659,032 S *	5/2012	Atwell et al. D10/63
D491,210 S *	6/2004	Raab et al. D15/199	D659,033 S *	5/2012	Bailey et al. D10/63
D491,589 S	6/2004	Raab et al.	8,327,555 B2 *	12/2012	Champ 33/503
D491,965 S	6/2004	Raab et al.	2008/0016711 A1	1/2008	Baebler
6,759,648 B2	7/2004	Baxter et al.	2011/0107613 A1	5/2011	Tait
D496,595 S	9/2004	Raab et al.	2011/0112786 A1	5/2011	Desforges et al.
D497,815 S	11/2004	Raab et al.	2011/0119026 A1	5/2011	Atwell et al.
6,817,108 B2	11/2004	Eaton	2011/0173825 A1	7/2011	Danielson et al.
D502,881 S	3/2005	Raab et al.	2011/0175745 A1	7/2011	Atwell et al.
D502,882 S	3/2005	Raab et al.	2011/0178762 A1	7/2011	York
D503,116 S	3/2005	Raab et al.	2011/0192043 A1	8/2011	Ferrari
D503,117 S	3/2005	Raab et al.	2011/0213247 A1	9/2011	Shammas
D503,348 S	3/2005	Raab et al.	2012/0017454 A1	1/2012	Ferrari
6,892,465 B2	5/2005	Raab et al.	FOREIGN PATENT DOCUMENTS		
6,904,691 B2	6/2005	Raab et al.	EP	0522610	1/1993
D507,978 S	8/2005	Raab et al.	FR	2740546	4/1997
6,925,722 B2	8/2005	Raab et al.	GB	2274526	7/1994
6,931,745 B2	8/2005	Granger	JP	05/031685	2/1993
6,952,882 B2	10/2005	Raab et al.	JP	2003/021133	1/2003
6,984,236 B2	1/2006	Raab	JP	2003/175484	6/2003
6,988,322 B2	1/2006	Raab et al.	WO	WO 98/08050	2/1998
7,003,892 B2	2/2006	Eaton et al.			
7,017,275 B2	3/2006	Raab et al.			
7,043,847 B2	5/2006	Raab et al.			

* cited by examiner

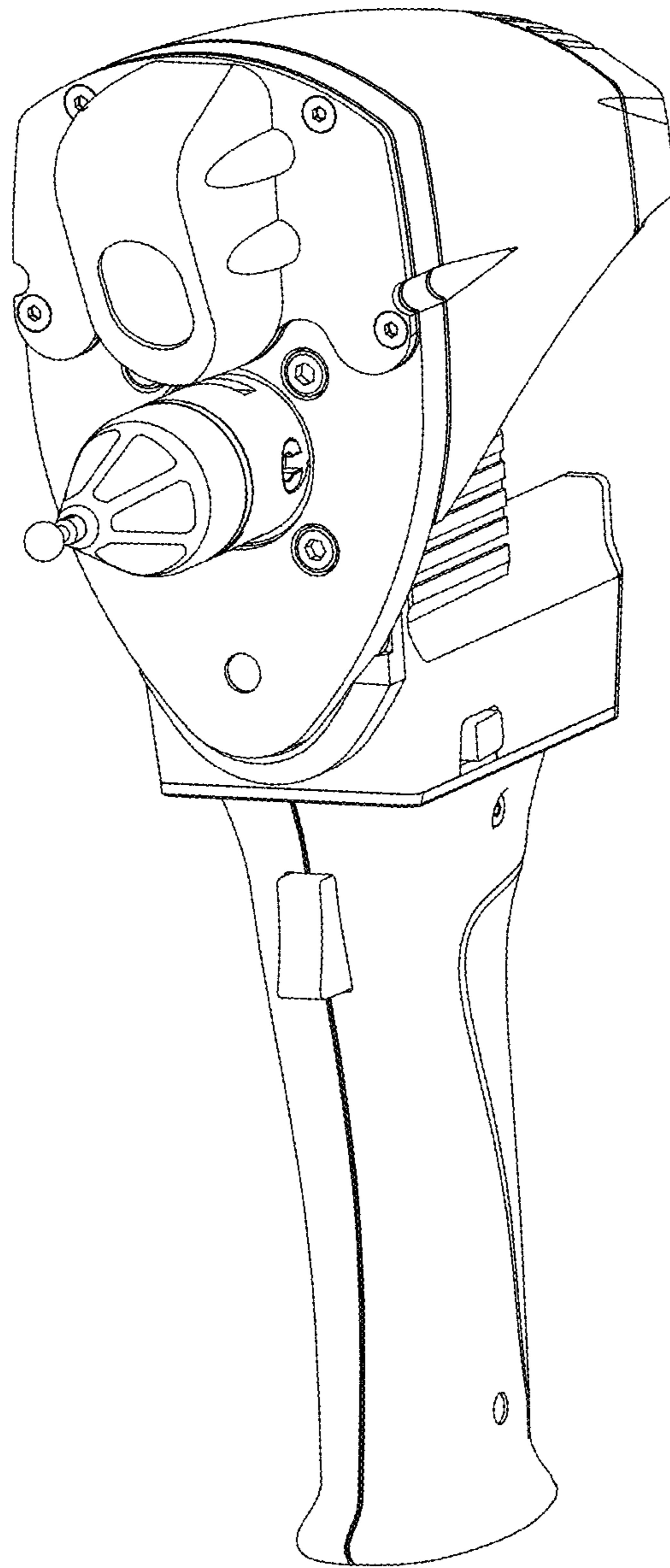

FIG. 1

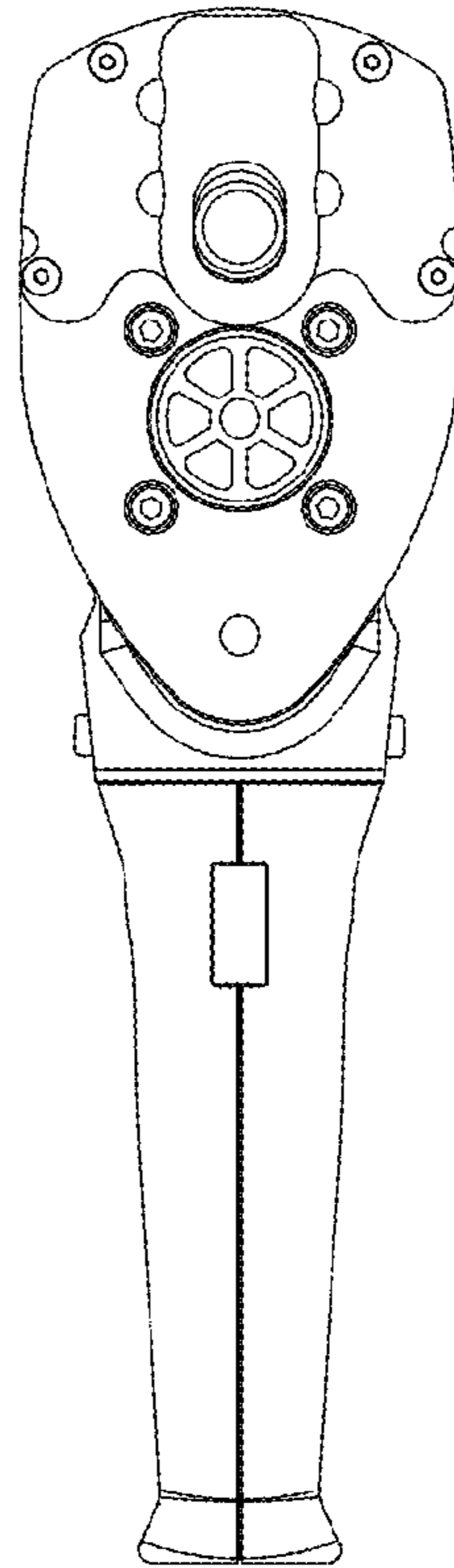

FIG. 2

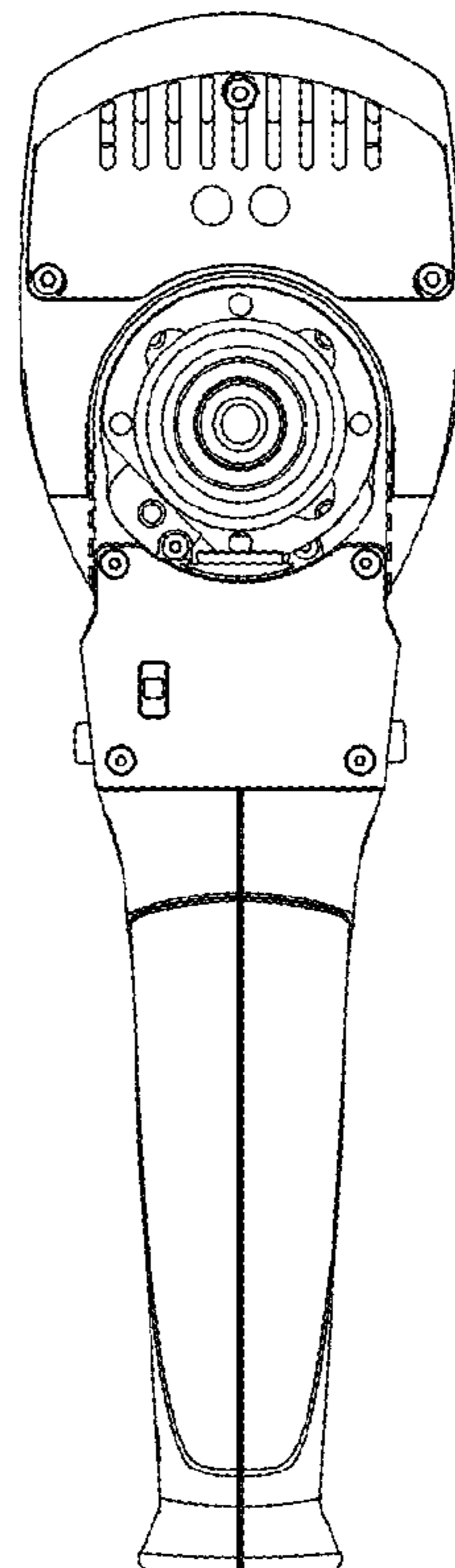

FIG. 3

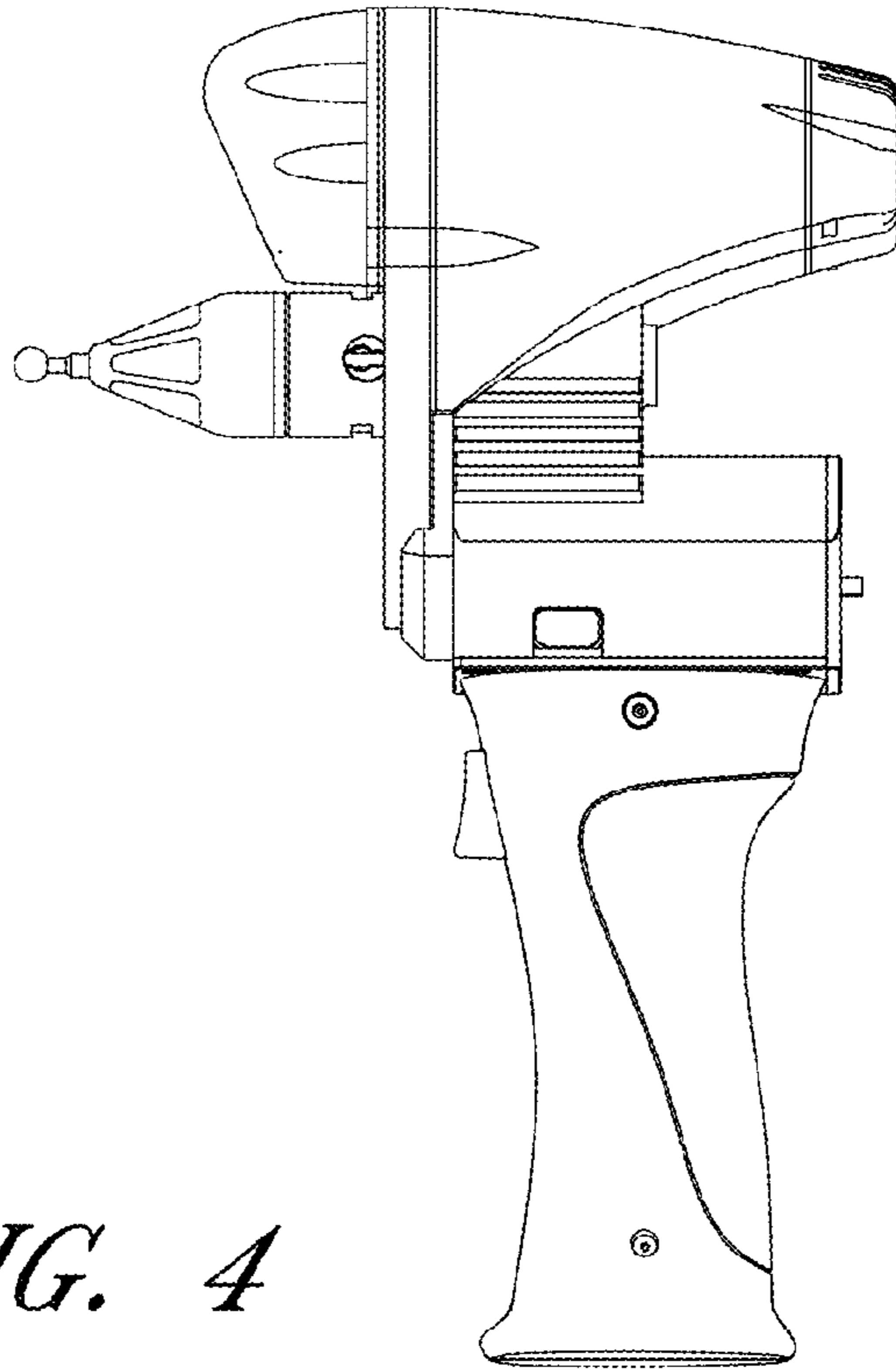

FIG. 4

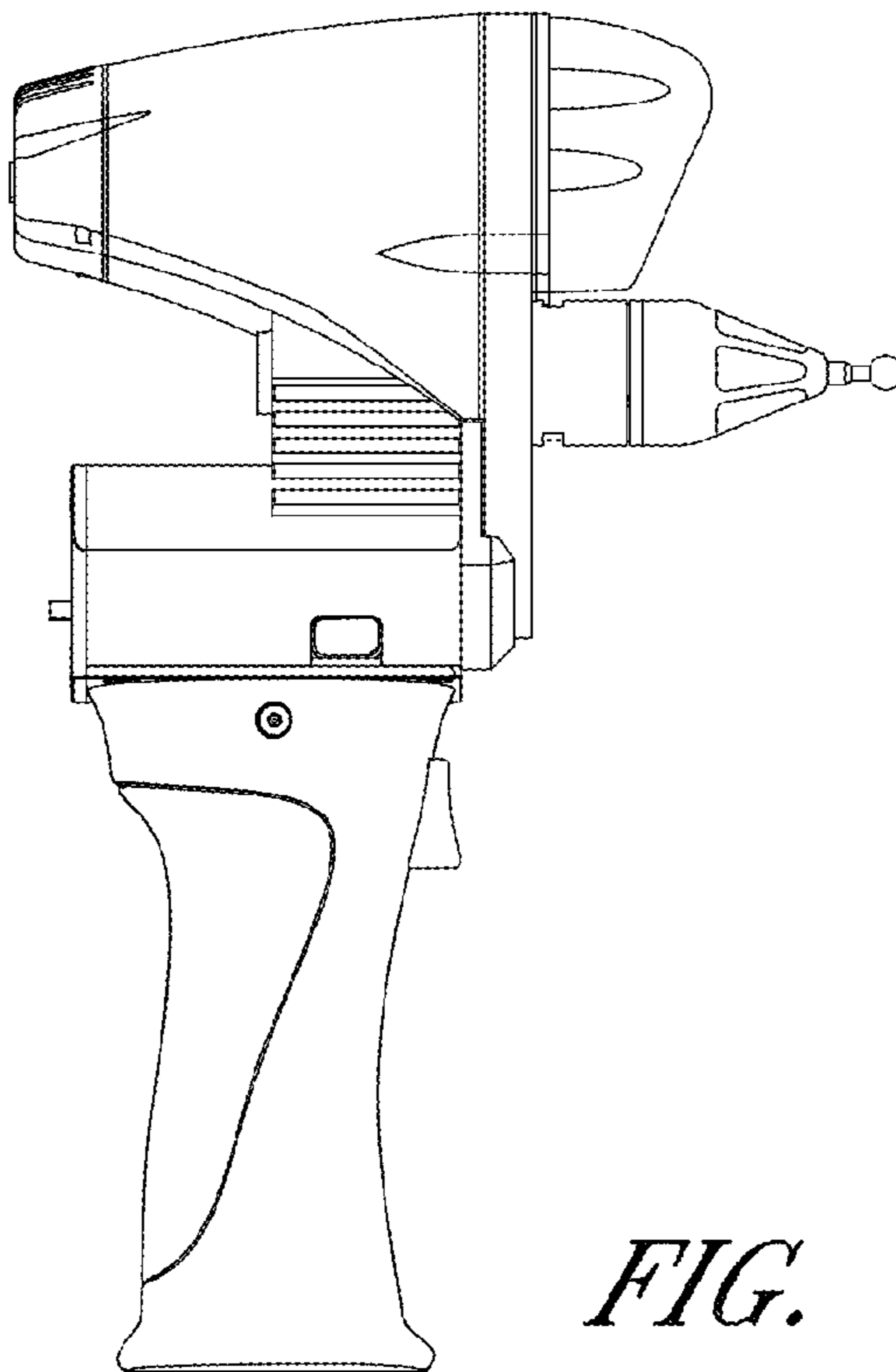

FIG. 5

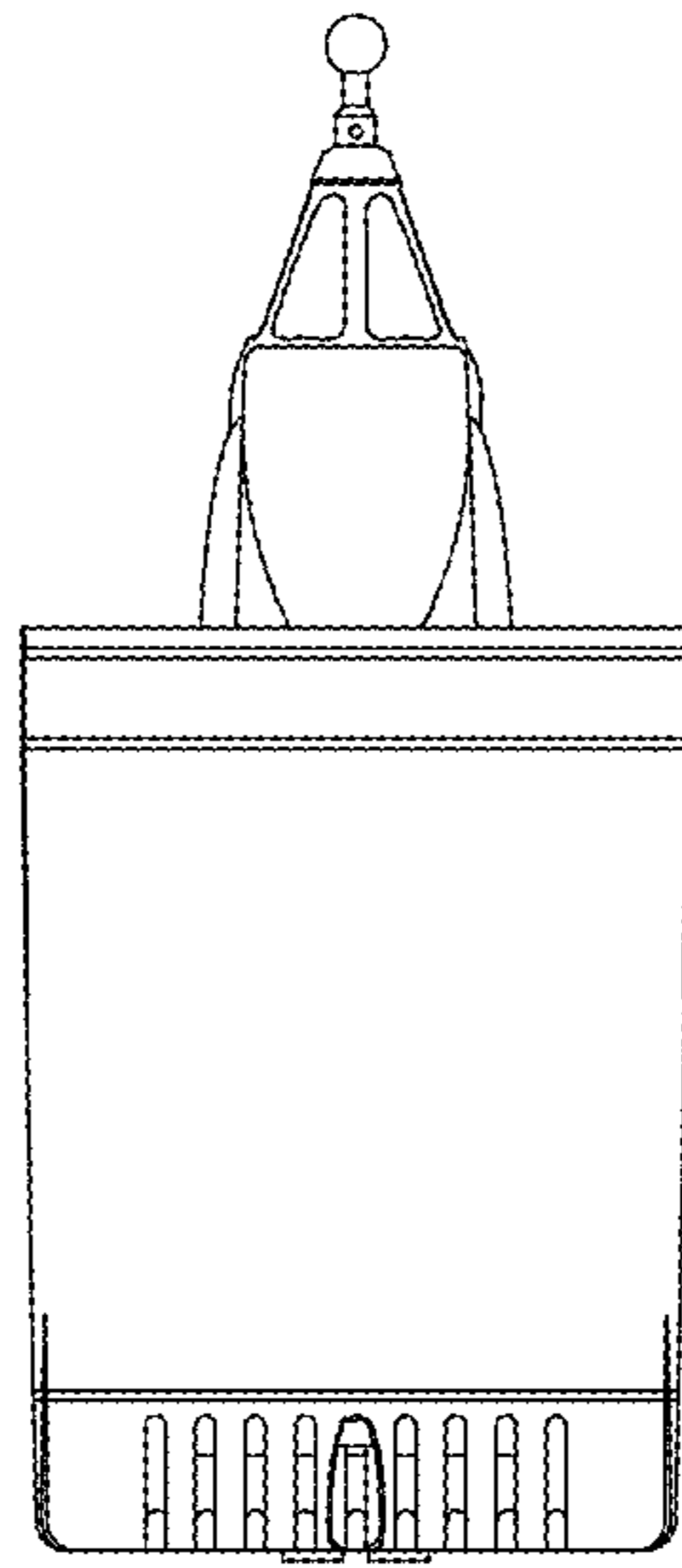

FIG. 6

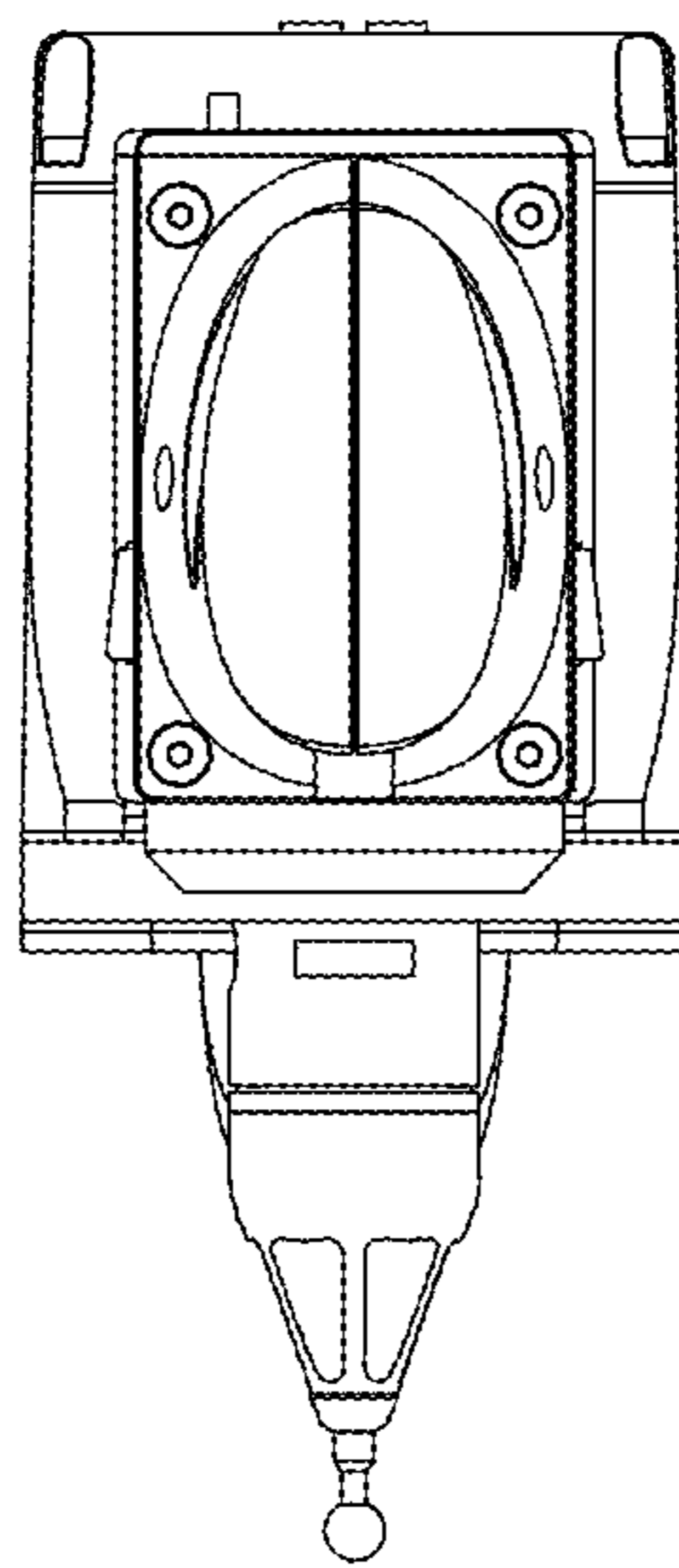

FIG. 7