



US00D686766S

(12) **United States Design Patent**
Morgenstern

(10) **Patent No.:** **US D686,766 S**

(45) **Date of Patent:** **** Jul. 23, 2013**

(54) **TAILLIGHT FOR A VEHICLE**

Primary Examiner — Marcus Jackson

(75) **Inventor:** **Sebastian Morgenstern, Munich (DE)**

(74) *Attorney, Agent, or Firm* — Crowell & Moring LLP

(73) **Assignee:** **Bayerische Motoren Werke
Aktiengesellschaft, Munich (DE)**

(57) **CLAIM**

The ornamental design for a taillight for a vehicle, as shown and described.

(**) **Term:** **14 Years**

(21) **Appl. No.:** **29/412,806**

DESCRIPTION

(22) **Filed:** **Feb. 8, 2012**

This application contains subject matter related to the following co-pending U.S. design patent applications:

(30) **Foreign Application Priority Data**

Aug. 9, 2011 (DE) 40 2011 003 969

Application Ser. No. 29/412,809, filed herewith and entitled “Vehicle, Toy, and/or Replicas Thereof”;

(51) **LOC (9) Cl.** **26-06**

Application Ser. No. 29/412,814, filed herewith and entitled “Vehicle, Toy, and/or Replicas Thereof”; and

(52) **U.S. Cl.**
USPC **D26/28**

Application Ser. No. 29/412,807, filed herewith and entitled “Taillight for a Vehicle”.

(58) **Field of Classification Search**
USPC D26/28–36; 362/459–468, 475–478,
362/485–487

FIG. 1 is a left perspective view of a first embodiment of a taillight for a vehicle according to my design;

See application file for complete search history.

FIG. 2 is a right perspective view thereof;

(56) **References Cited**

U.S. PATENT DOCUMENTS

D550,380 S *	9/2007	Lin	D26/28
D552,769 S *	10/2007	Leclercq	D26/28
D565,211 S *	3/2008	Haller et al.	D26/28
D602,616 S *	10/2009	Okamura et al.	D26/28
D605,793 S *	12/2009	Weil	D26/28
D638,962 S	5/2011	Froehlich		

FIG. 3 is a front view thereof;

FIG. 4 is a left side view thereof; and

FIG. 5 is a top view thereof.

FOREIGN PATENT DOCUMENTS

WO DM/072624 5/2010

FIG. 6 is a right perspective view of a second embodiment of a taillight for a vehicle showing my new design, with the taillight for a vehicle for the opposite side of the vehicle being depicted in the first embodiment;

FIG. 7 is a left perspective view thereof;

FIG. 8 is a front view thereof;

FIG. 9 is a right side view thereof; and,

FIG. 10 is a top view thereof.

The broken lines are for illustrative purposes only and form no part of the claimed design.

* cited by examiner

1 Claim, 6 Drawing Sheets

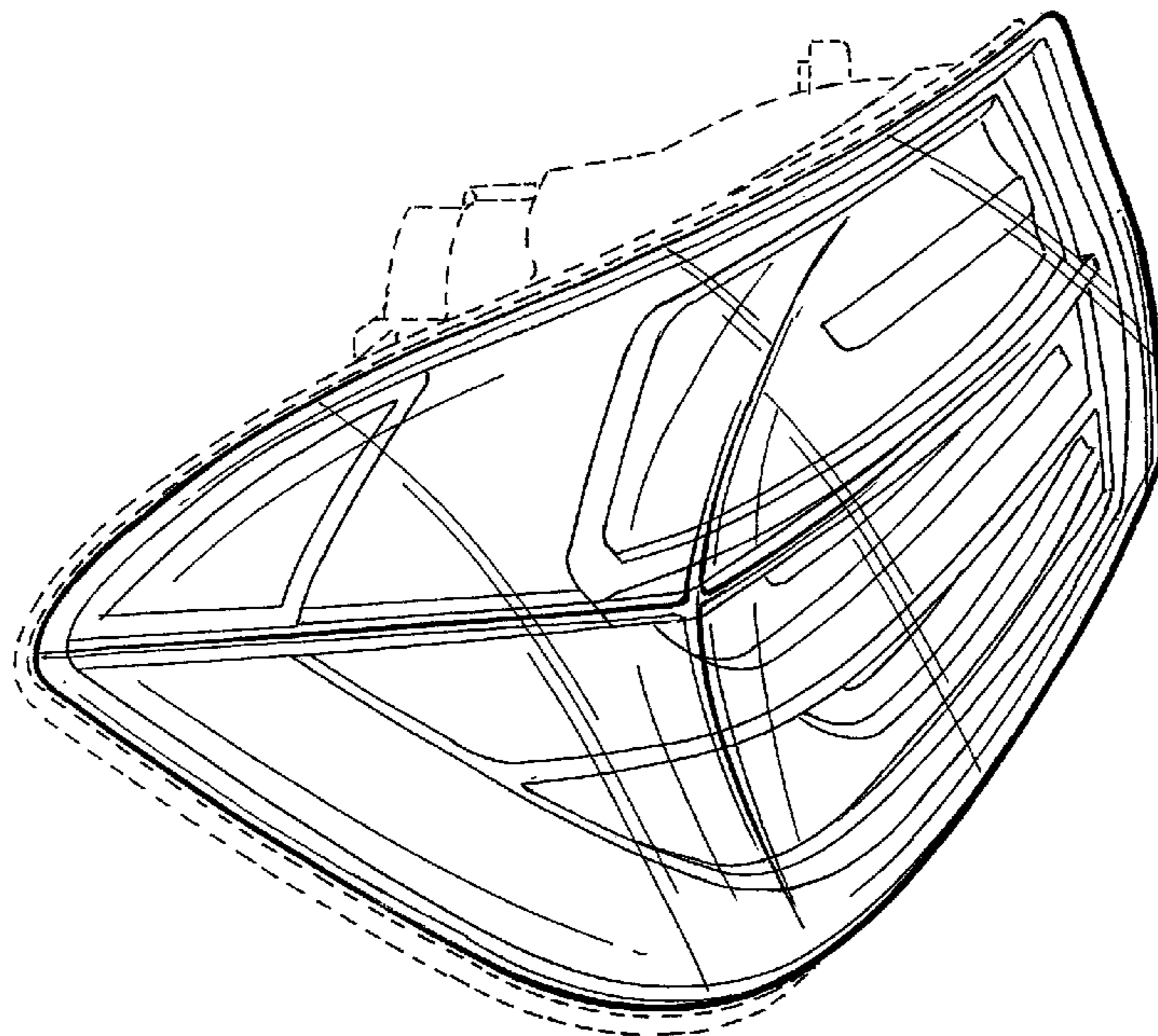

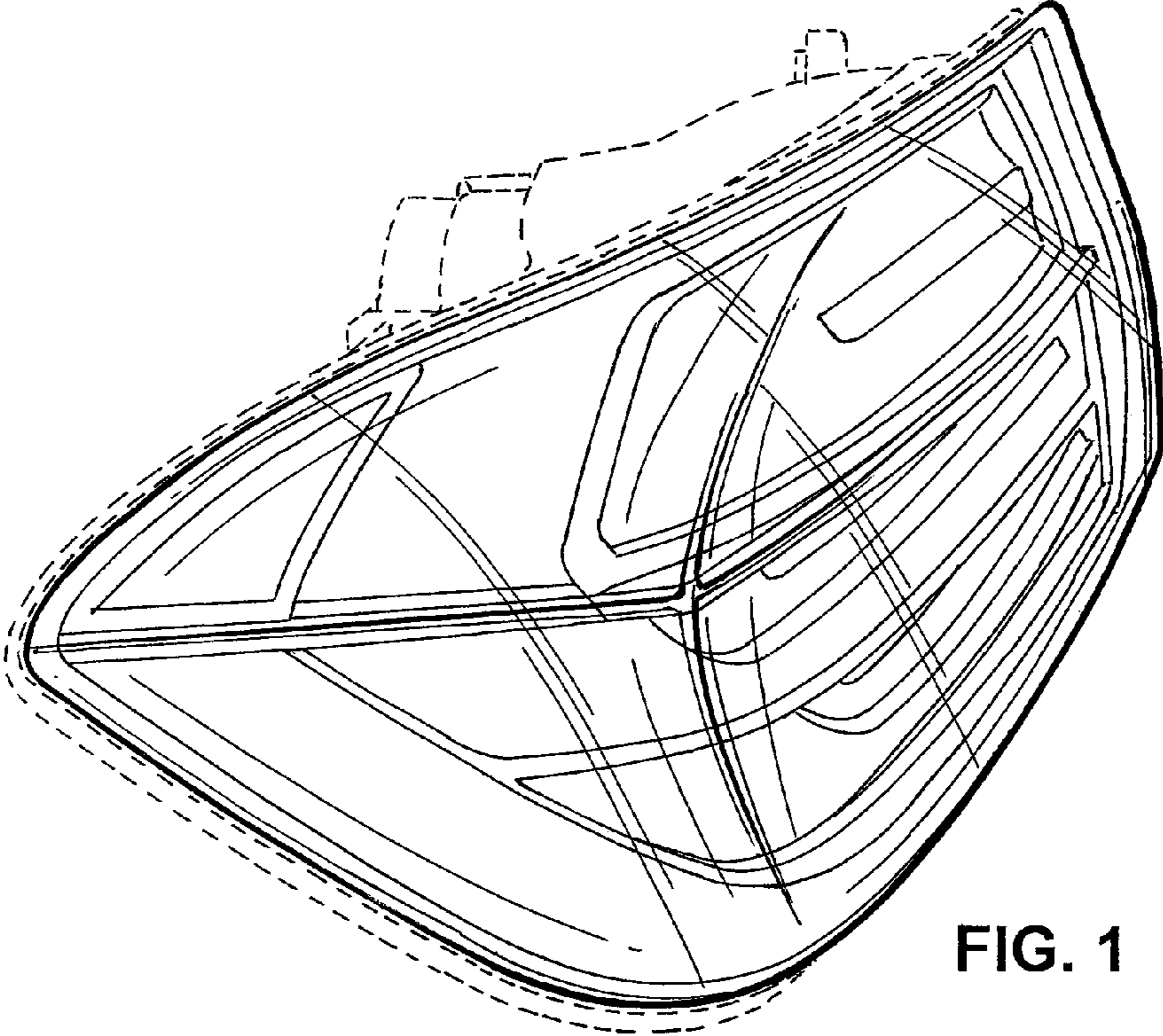

FIG. 1

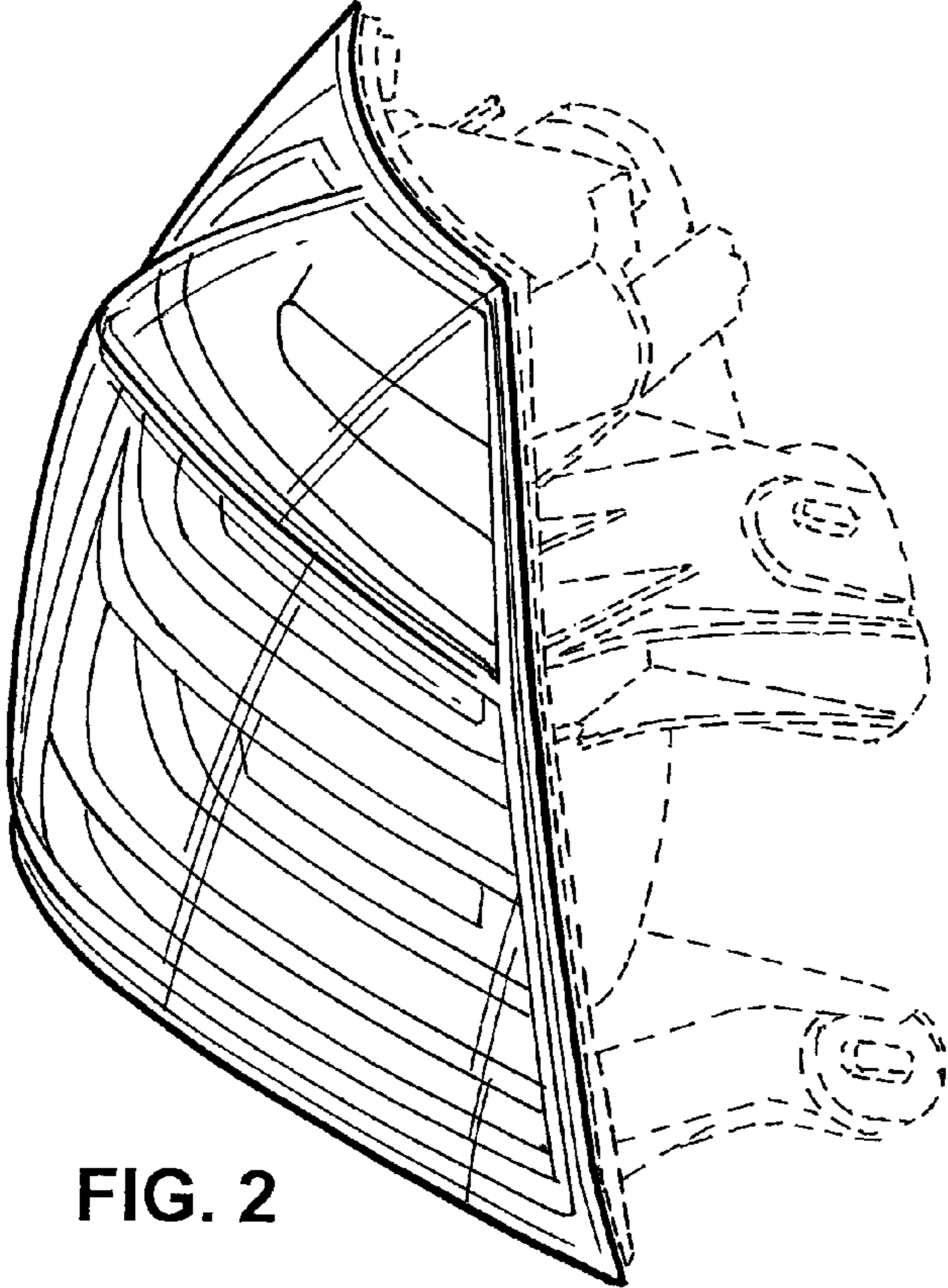

FIG. 2

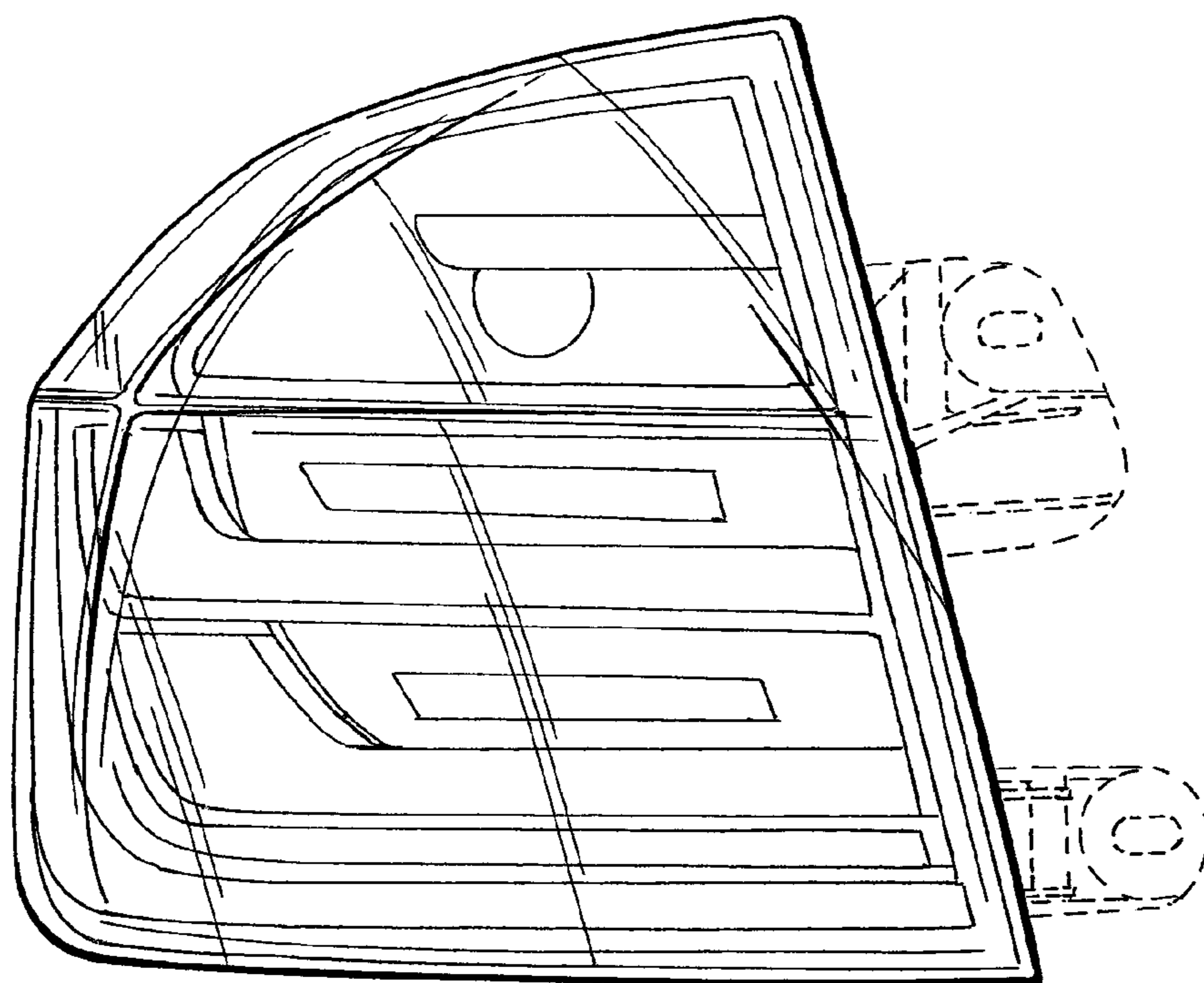

FIG. 3

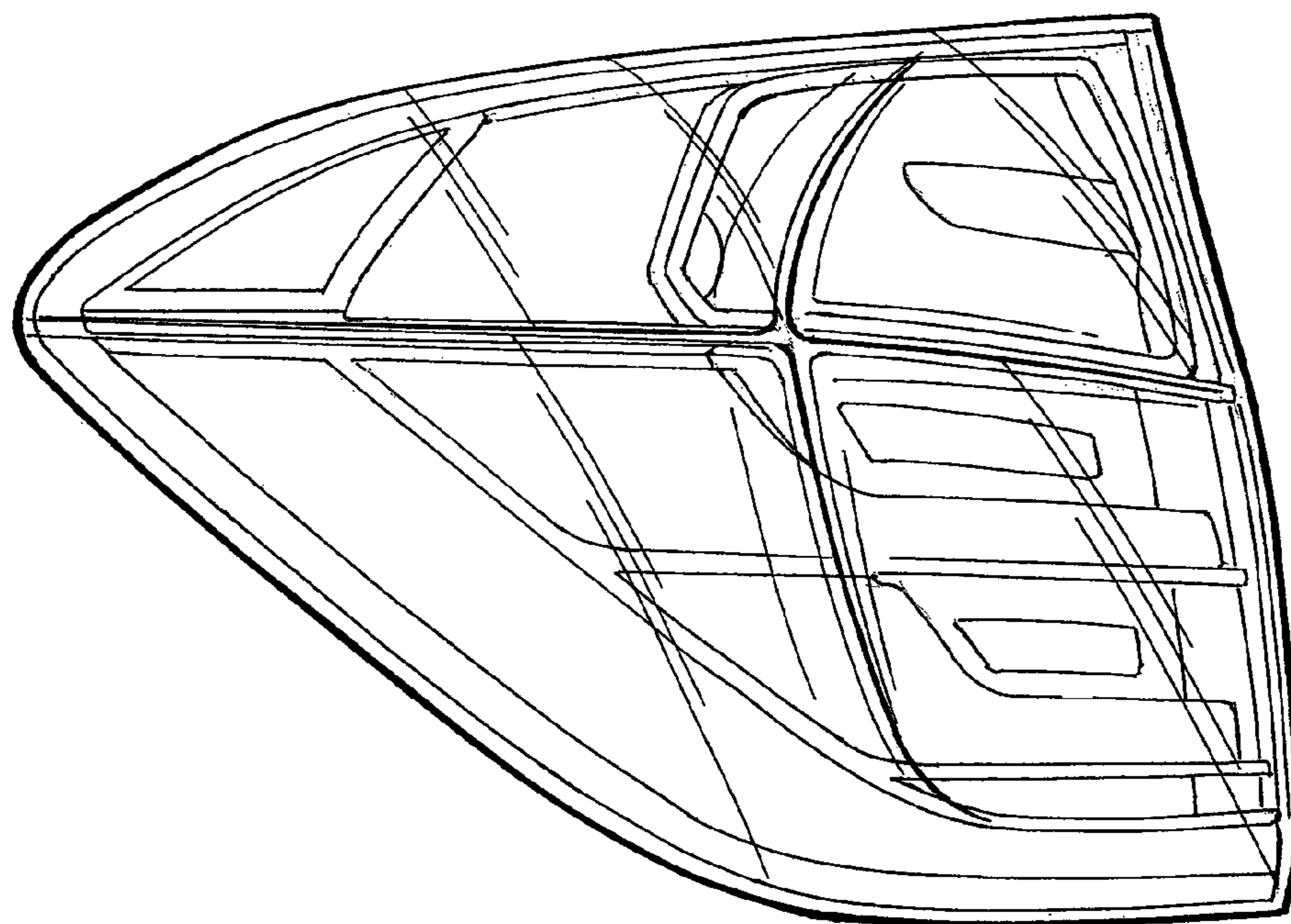

FIG. 4

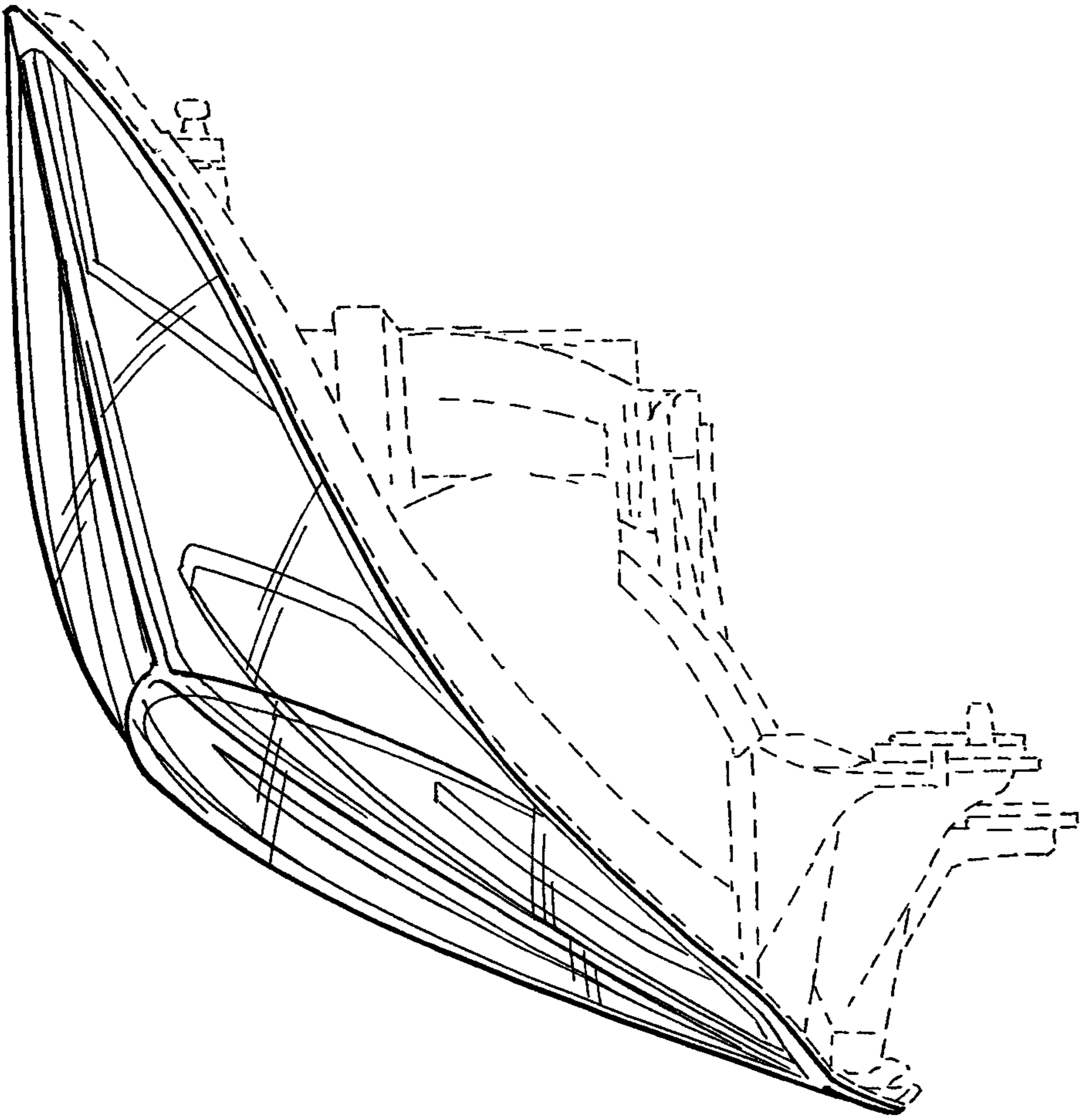

FIG. 5

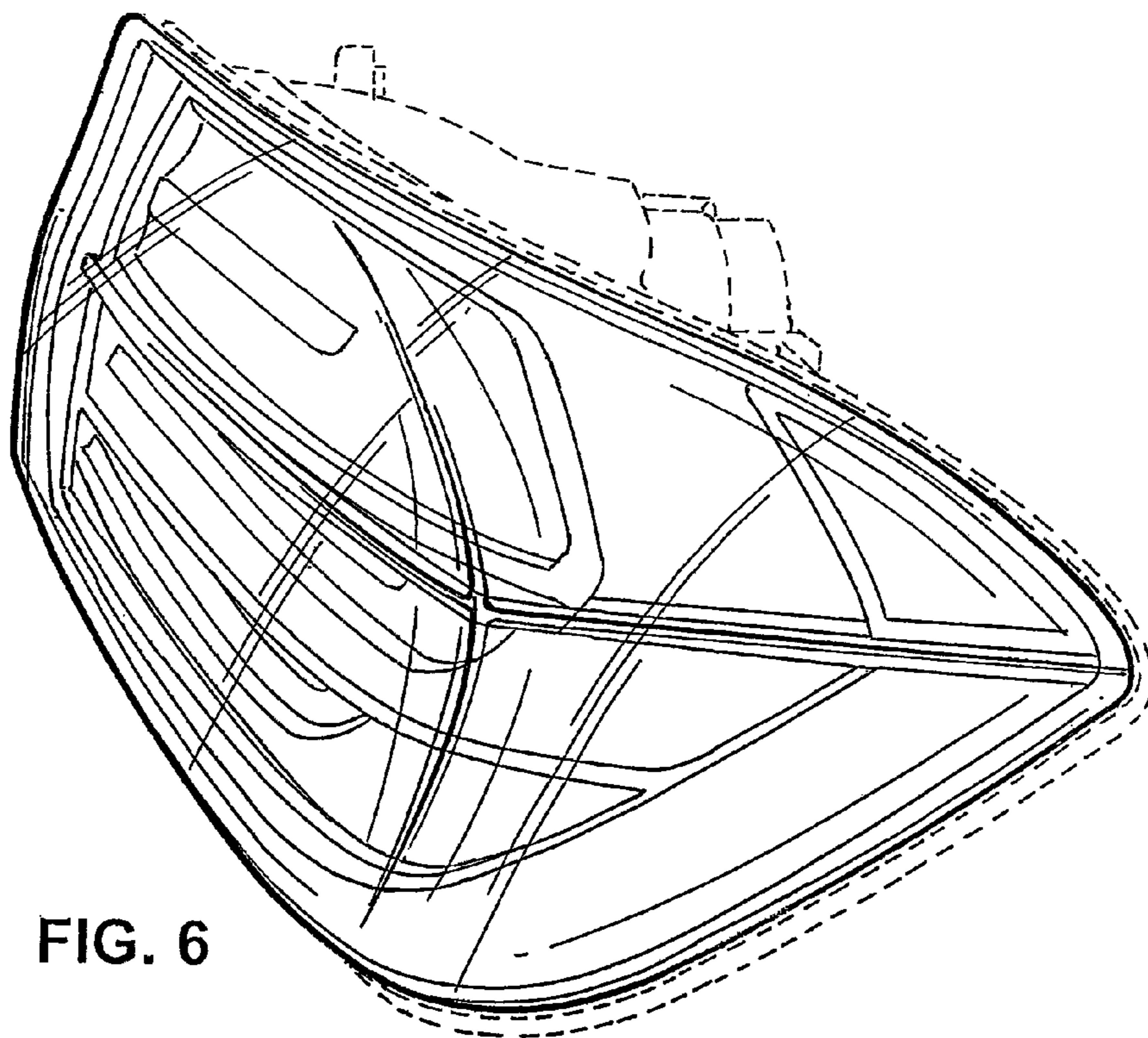

FIG. 6

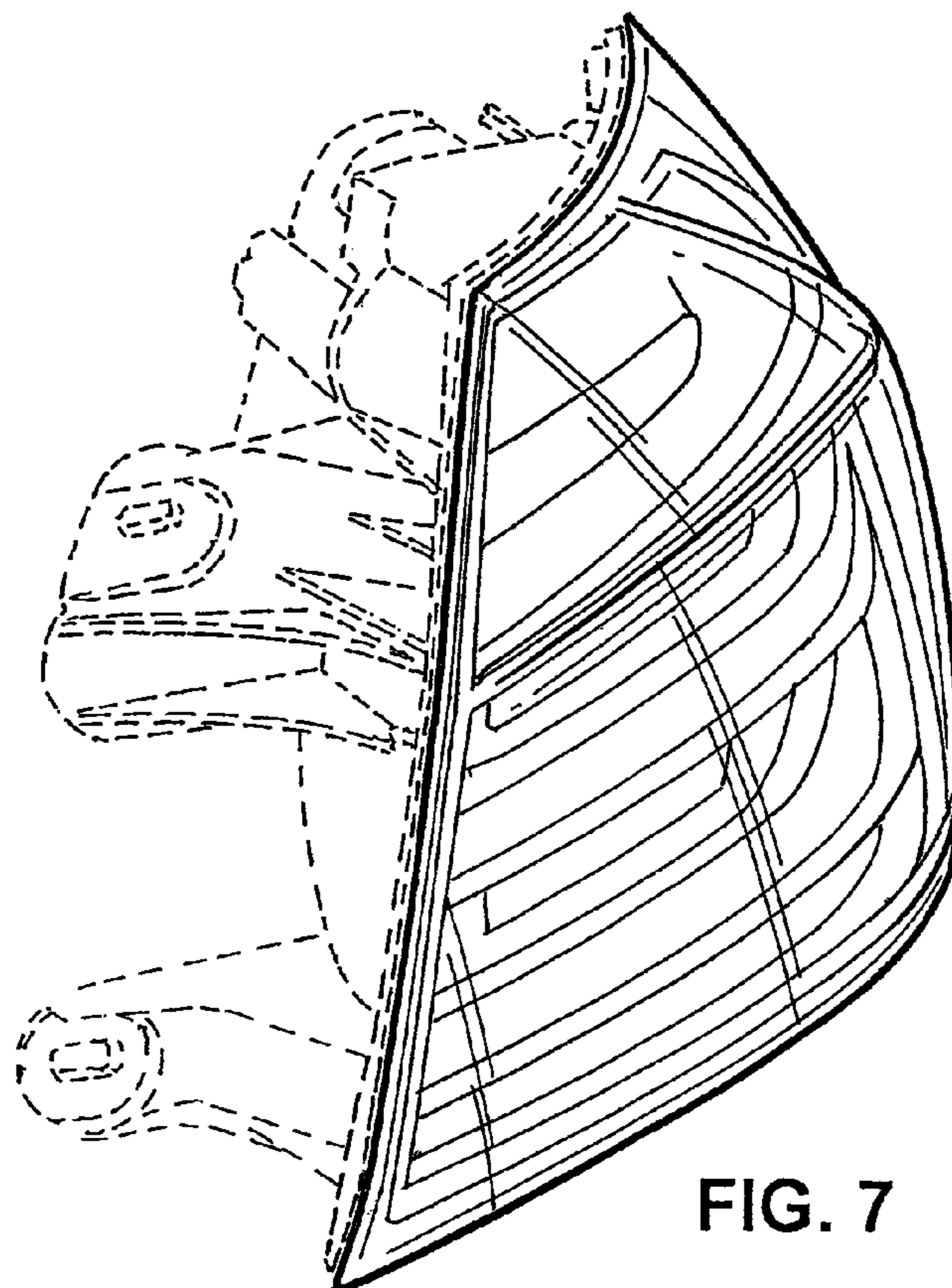

FIG. 7

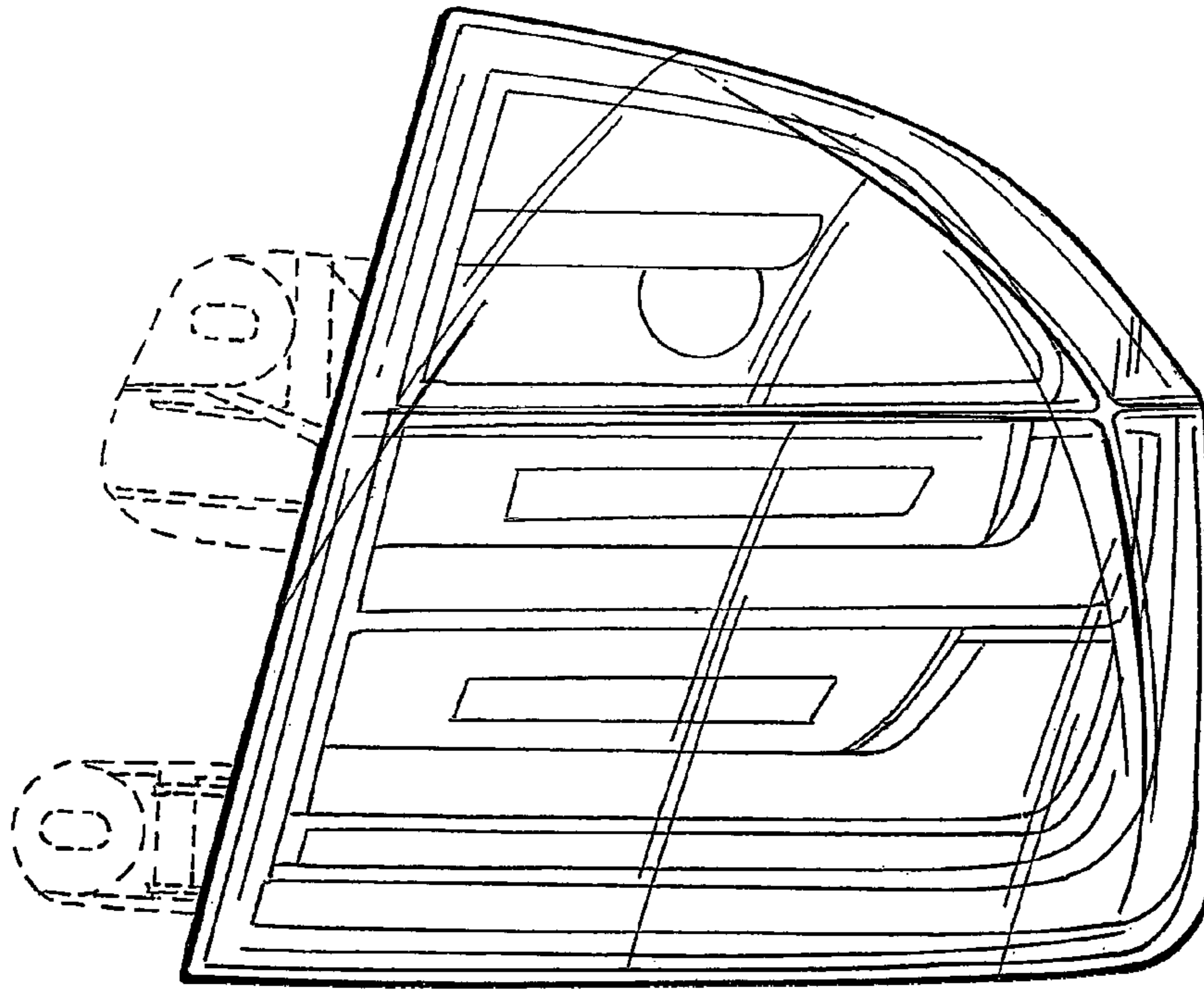

FIG. 8

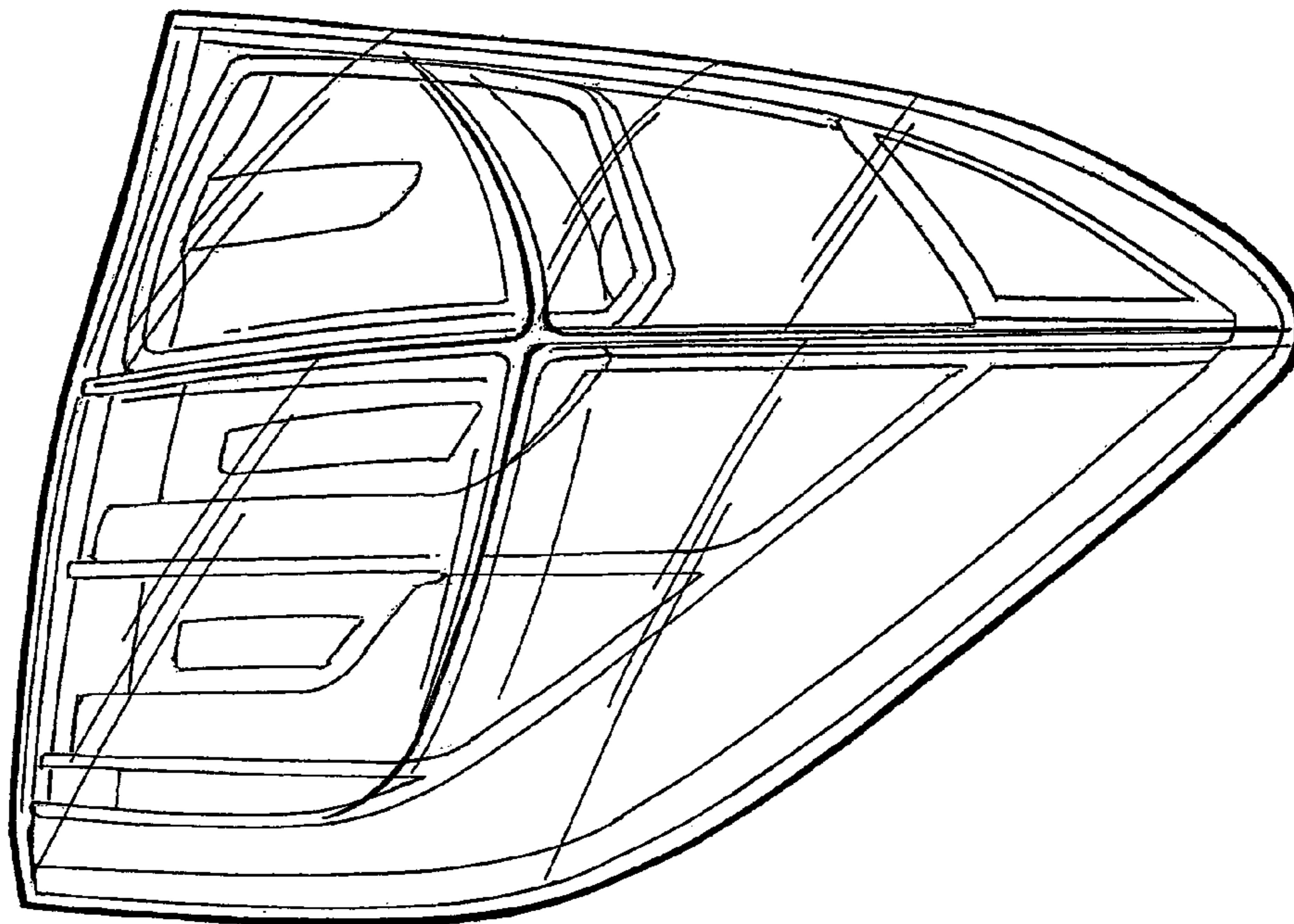

FIG. 9

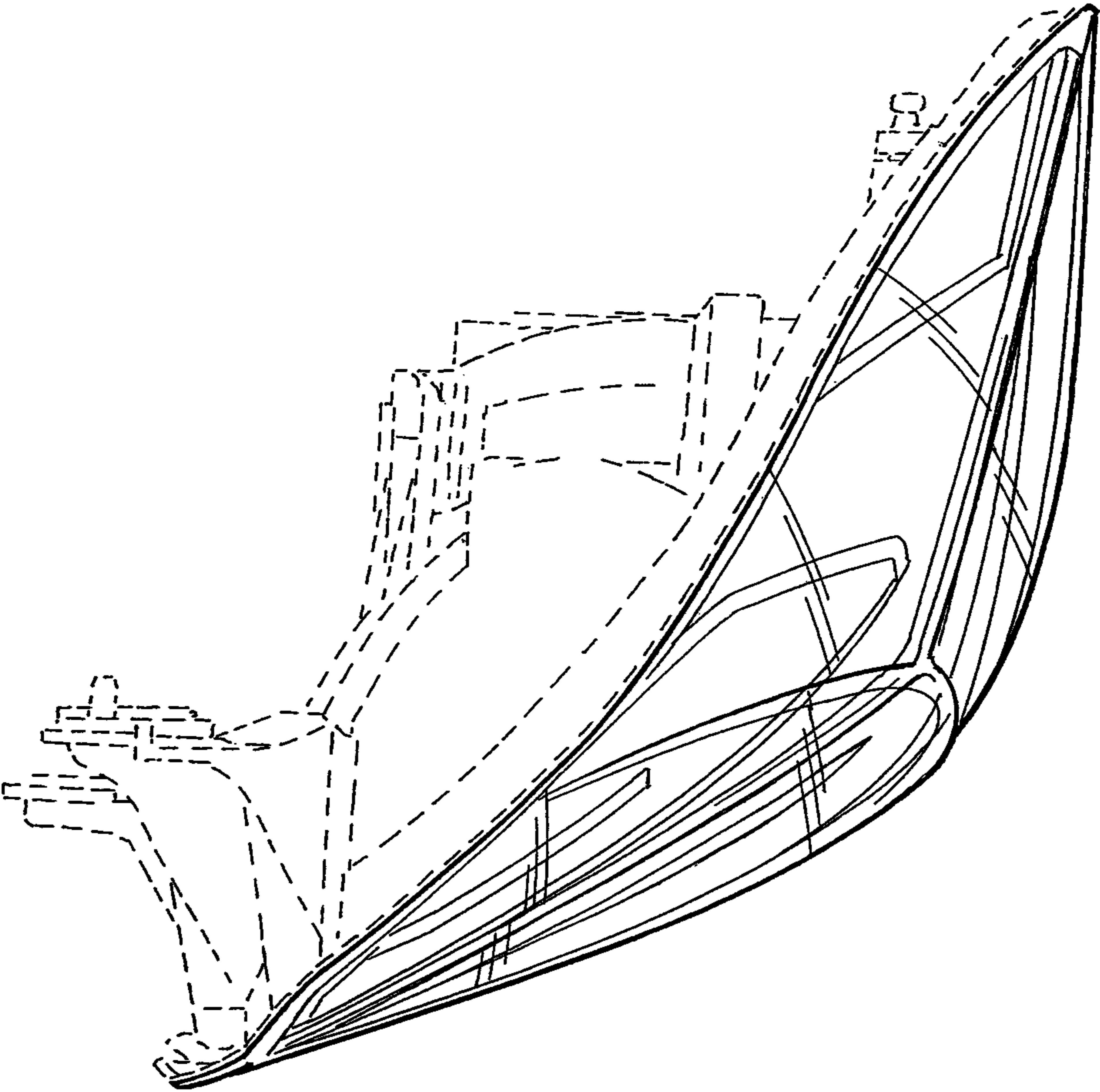

FIG. 10