

US00D686114S

(12) **United States Design Patent**  
**Madden**

(10) **Patent No.:** **US D686,114 S**  
(45) **Date of Patent:** **\*\* Jul. 16, 2013**

(54) **MOTORCYCLE INNER PRIMARY COVER**

(75) Inventor: **Kenneth E. Madden**, Andover, MN  
(US)

(73) Assignee: **Kuryakyn Holdings, LLC**, Somerset,  
WI (US)

(\*\*) Term: **14 Years**

(21) Appl. No.: **29/413,805**

(22) Filed: **Feb. 21, 2012**

(51) **LOC (9) Cl.** ..... **12-11**

(52) **U.S. Cl.**  
USPC ..... **D12/126**

(58) **Field of Classification Search**  
USPC ..... D12/126, 127, 110, 114; 280/288.4,  
280/304.3; 180/219, 231; 123/198 R, 196 P,  
123/195 R, 195 A, 195 C, 198 E; 474/144,  
474/146; D15/1-5, 149; 74/6, 7 A, 606 R;  
290/38 R, 38 C

See application file for complete search history.

(56) **References Cited**

**U.S. PATENT DOCUMENTS**

6,805,219 B2 \* 10/2004 Yasuda et al. .... 181/204  
7,174,875 B2 \* 2/2007 Liang et al. .... 123/195 R  
D570,746 S \* 6/2008 Arndt et al. .... D12/126  
D581,322 S \* 11/2008 Madden ..... D12/126  
7,849,948 B2 \* 12/2010 Clarkson et al. .... 180/227

**OTHER PUBLICATIONS**

J & P Cycles® 2010 Parts & Accessories for your Harley-Davidson®  
Motorcycle catalog. Inner Primary Covers on p. 605.\*

\* cited by examiner

*Primary Examiner* — Susan M Lee

*Assistant Examiner* — Linda G Brooks

(74) *Attorney, Agent, or Firm* — Dicke, Billig & Czaja,  
PLLC

(57) **CLAIM**

The ornamental design for a motorcycle inner primary cover,  
as shown and described.

**DESCRIPTION**

FIG. 1 is a top perspective view of the motorcycle inner  
primary cover of the present invention.

FIG. 2 is a first side view thereof.

FIG. 3 is a second side view thereof, the second side view  
being opposite the first side view.

FIG. 4 is a top view thereof.

FIG. 5 is a bottom view thereof.

FIG. 6 is a first end view thereof.

FIG. 7 is a second end view thereof, the second end view  
being opposite the first end view.

FIG. 8 is a perspective view of a motorcycle cylinder base  
cover for use in combination with the motorcycle inner pri-  
mary cover of FIG. 1.

FIG. 9 is a front side view thereof.

FIG. 10 is a rear side view thereof.

FIG. 11 is a top view thereof.

FIG. 12 is a bottom view thereof.

FIG. 13 is a first end view thereof; and,

FIG. 14 is a second end view thereof, the second end view  
being opposite the first end view.

The top surface portions and the bottom surface of the motor-  
cycle inner primary cover, and the front side surface portions  
and rear side of the motorcycle cylinder base cover shown in  
broken lines form no part of the claimed design.

**1 Claim, 11 Drawing Sheets**

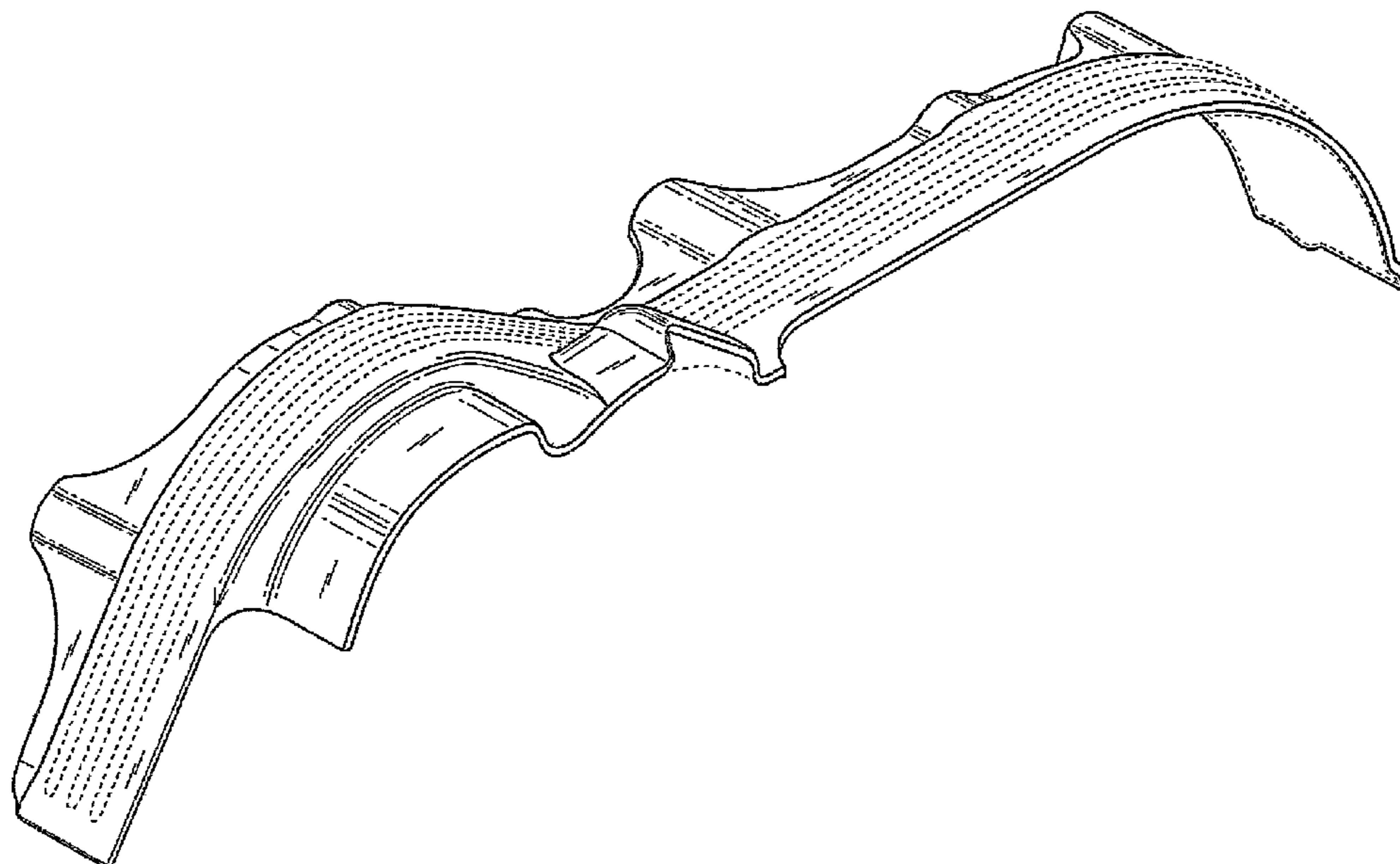

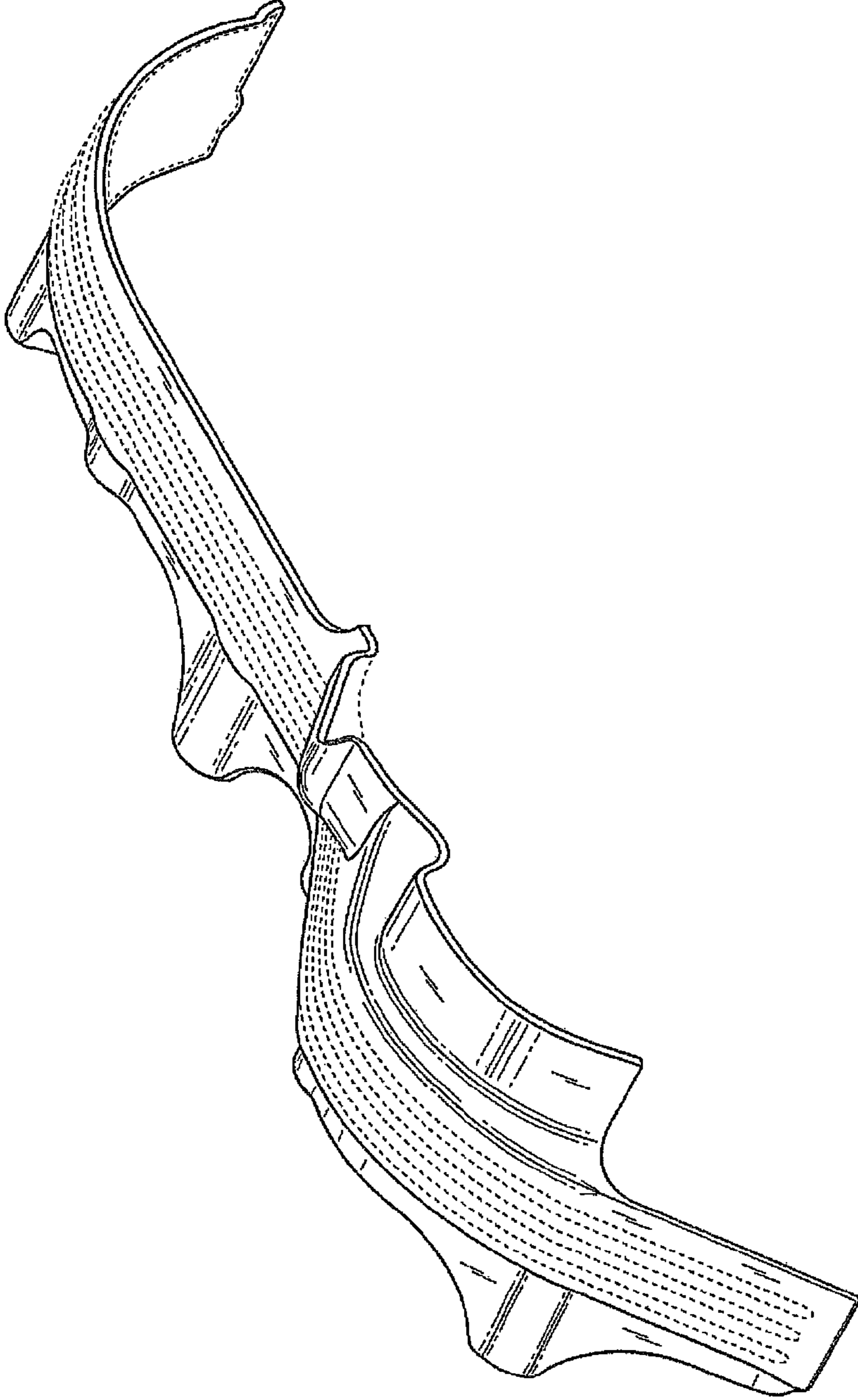

Fig. 1

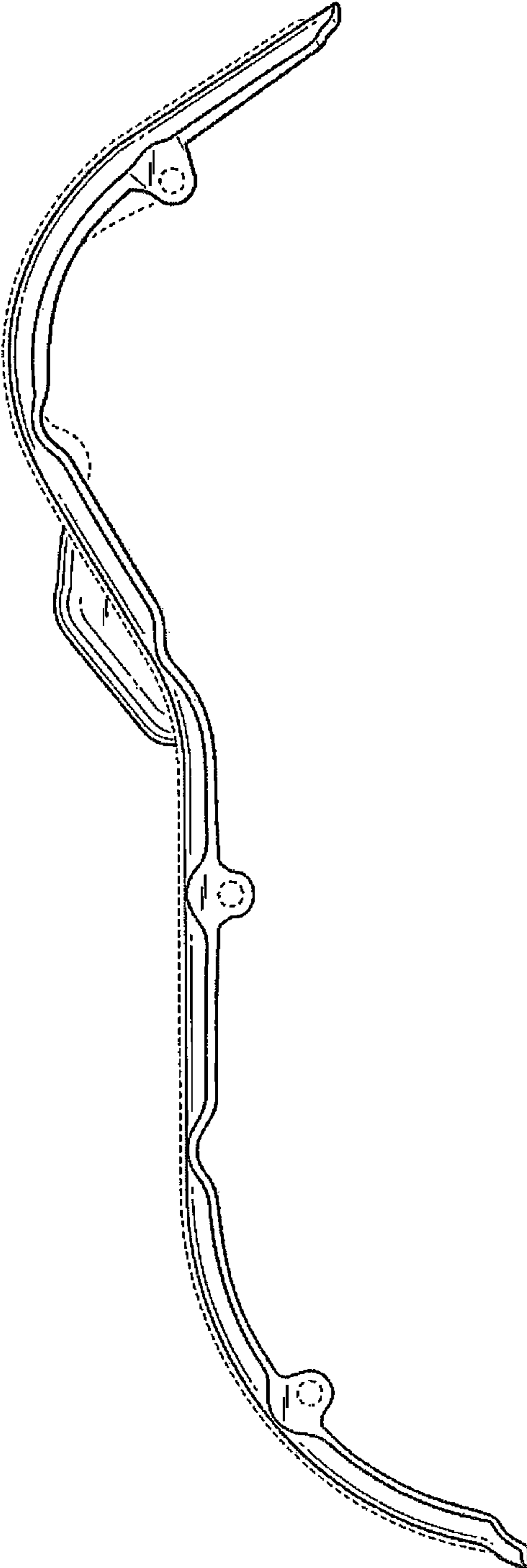

Fig. 2

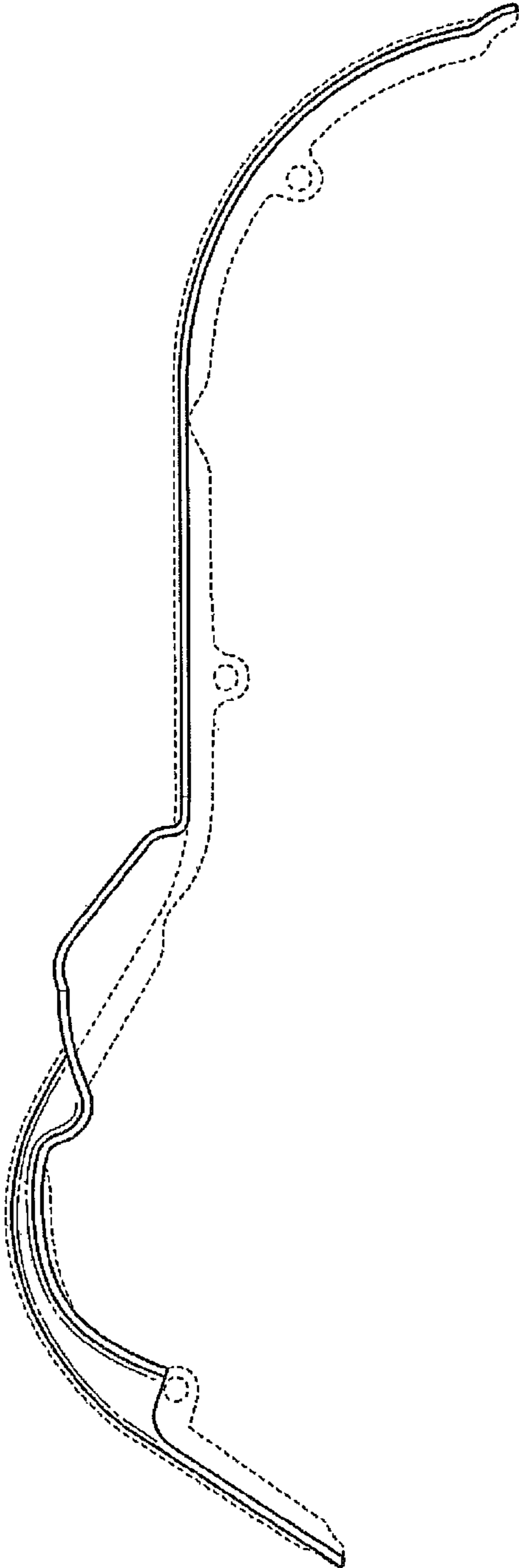

Fig. 3

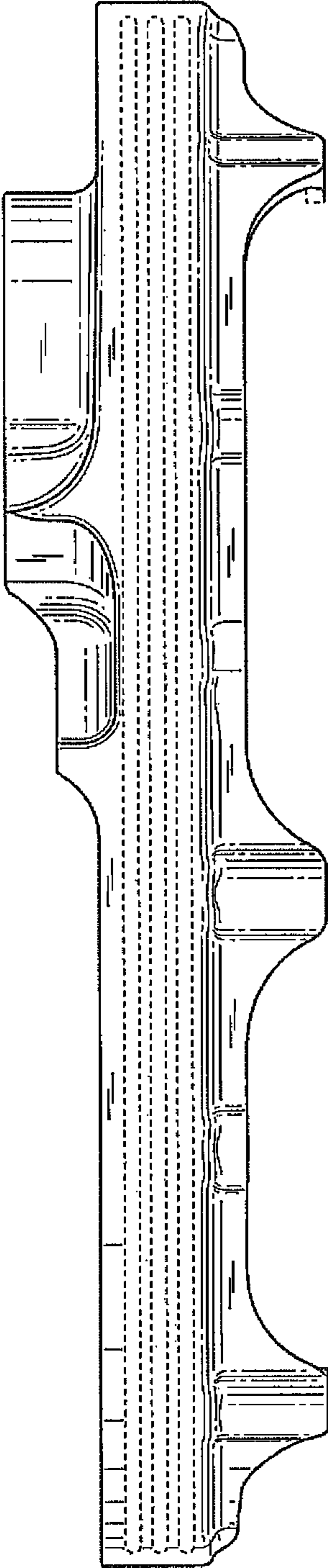

Fig. 4

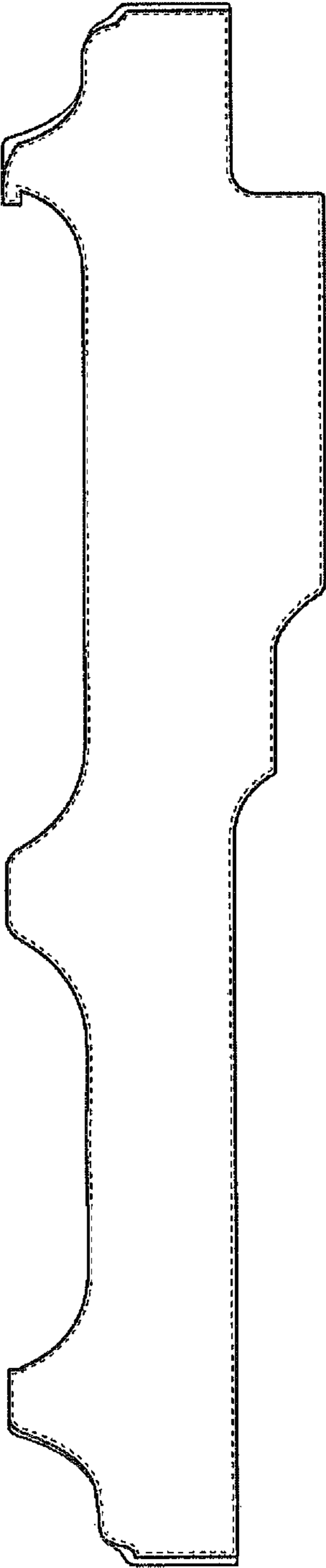

Fig. 5

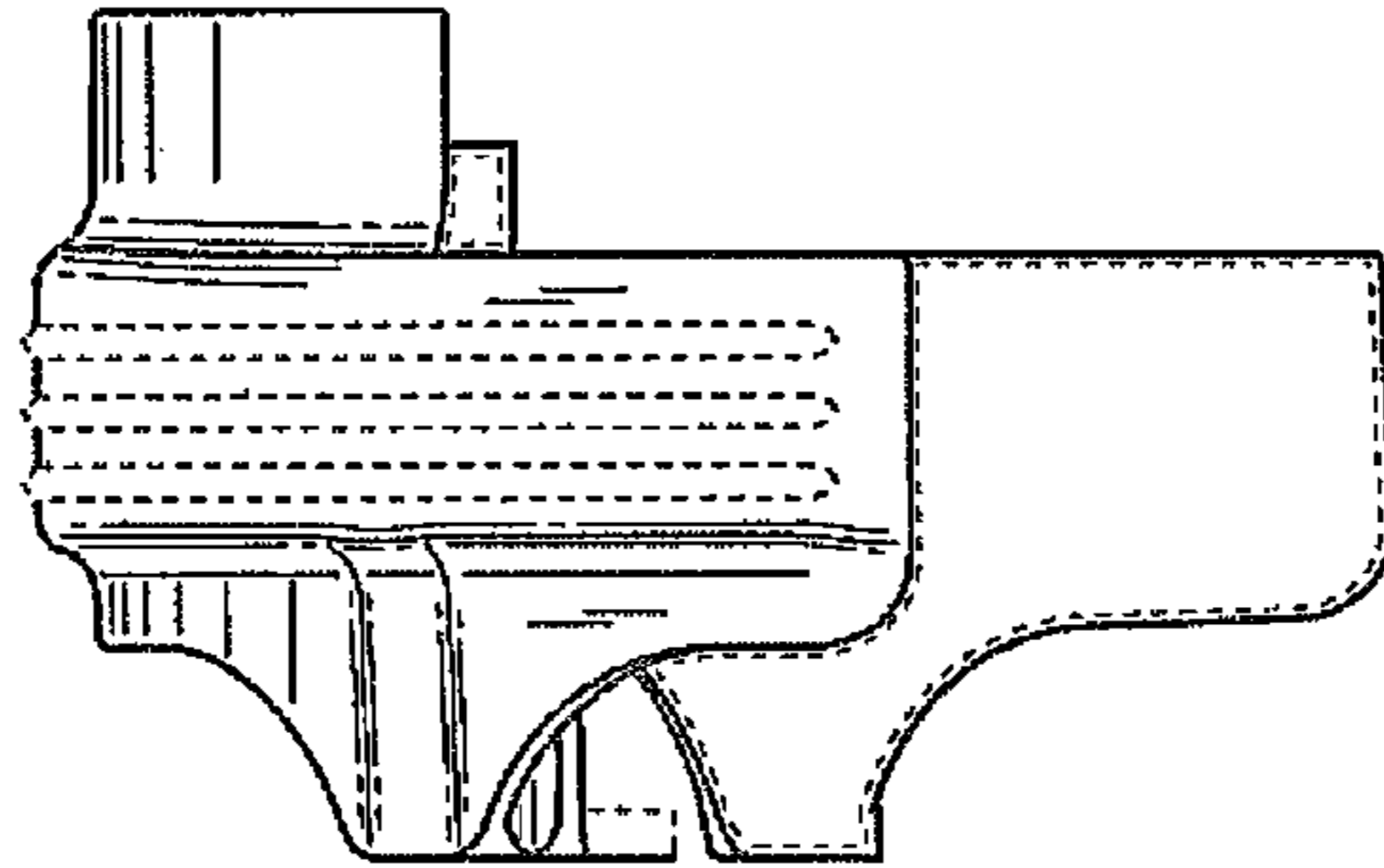

Fig. 7

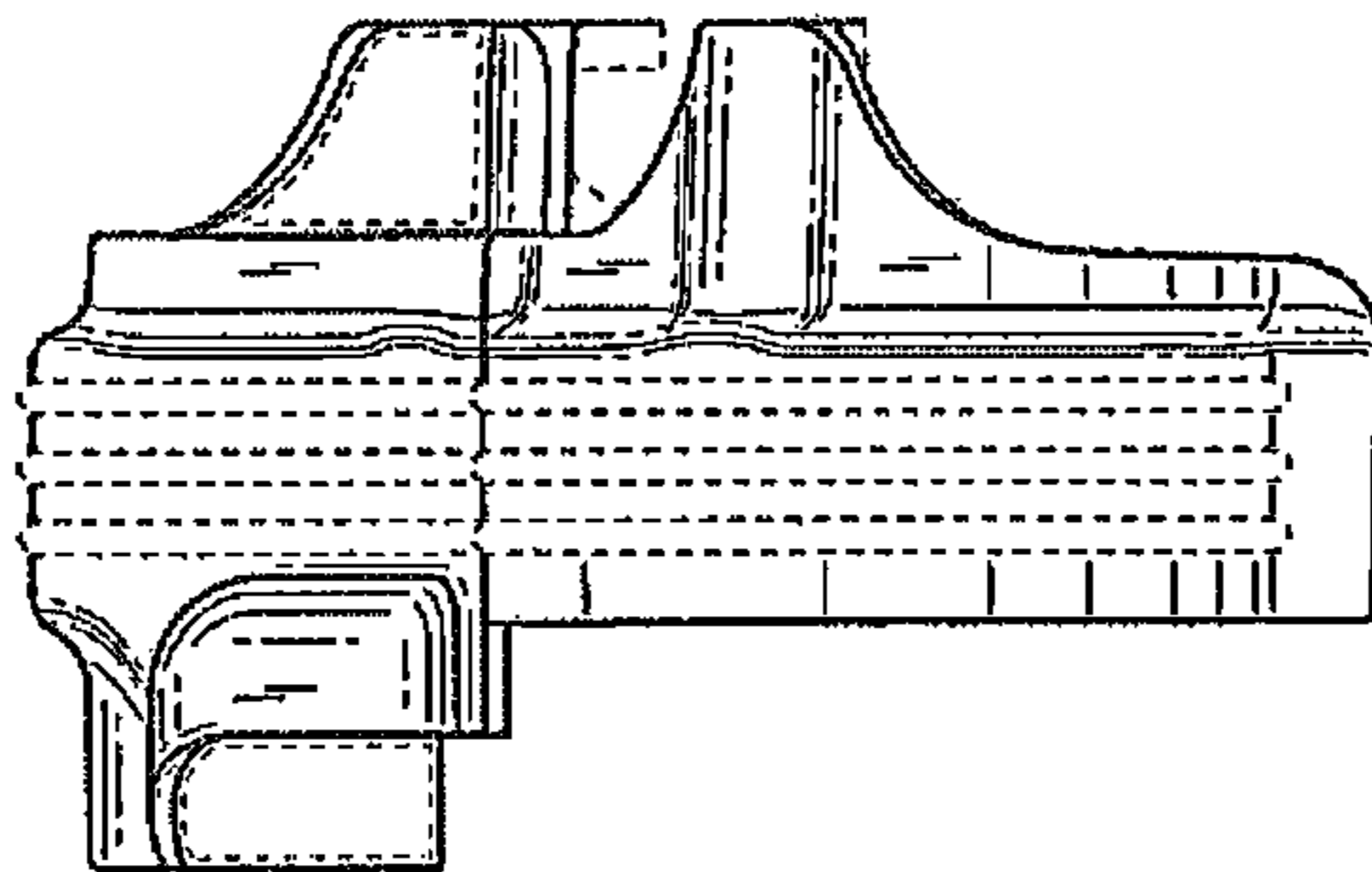

Fig. 6

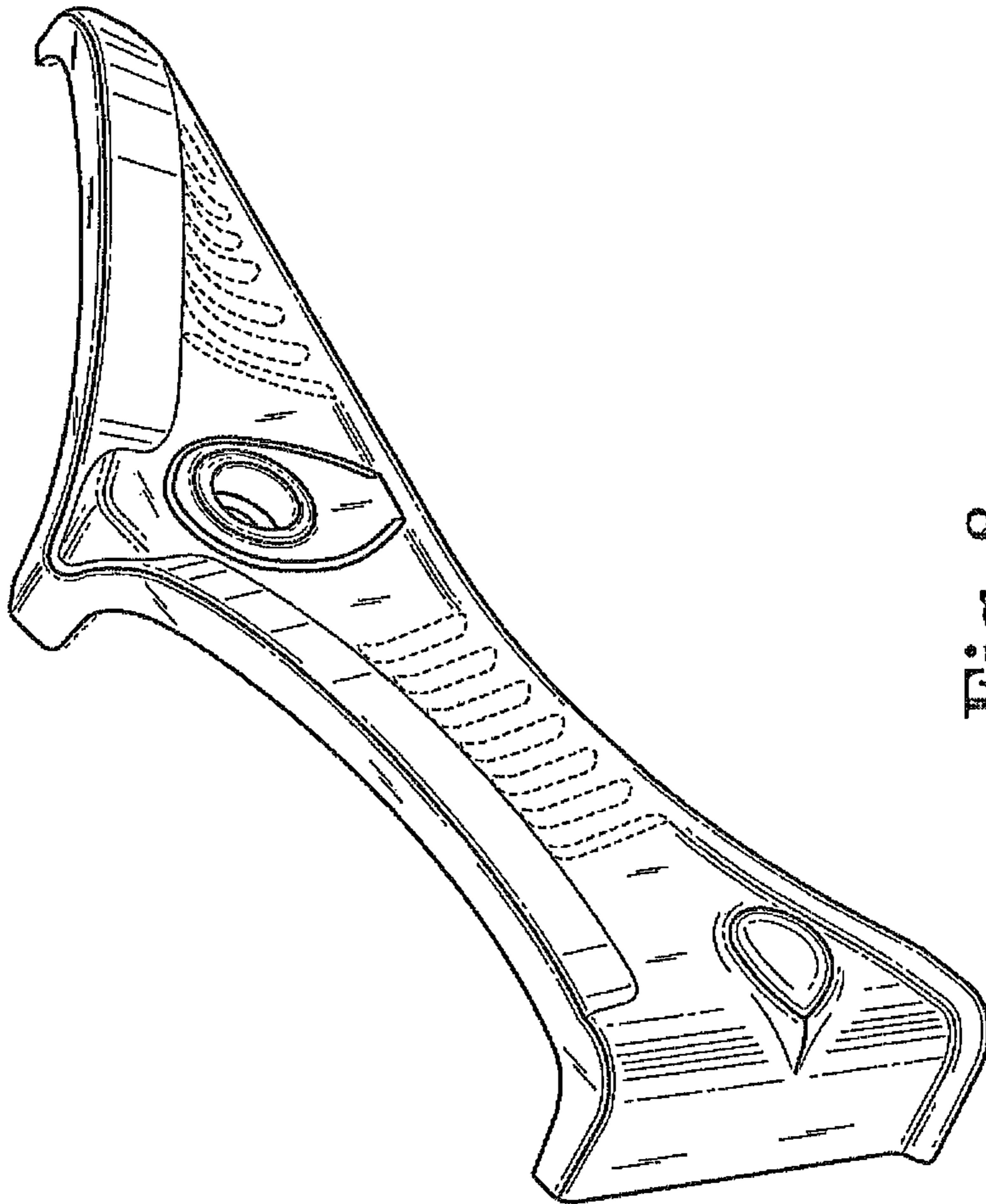

Fig. 8



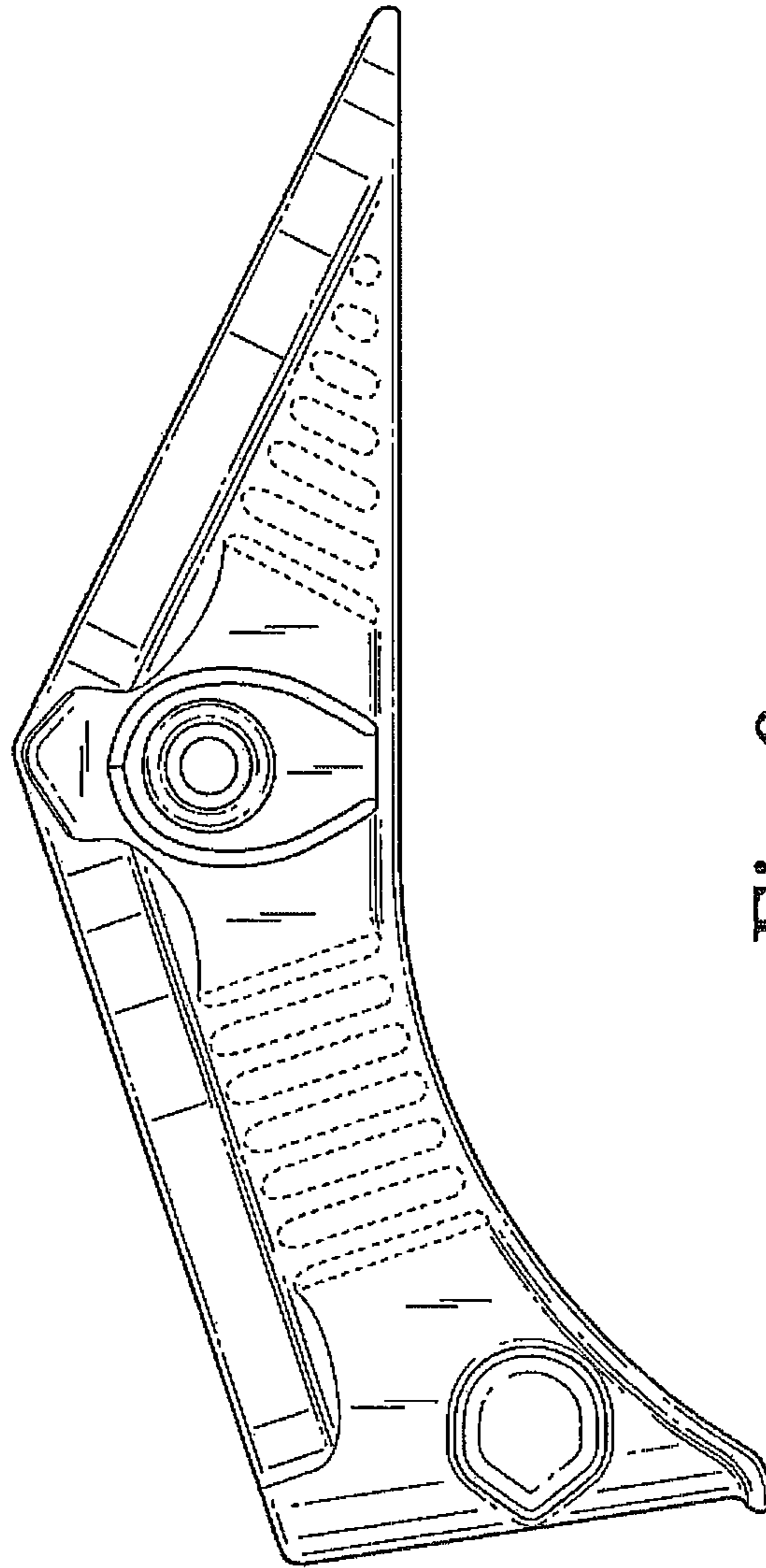

Fig. 9

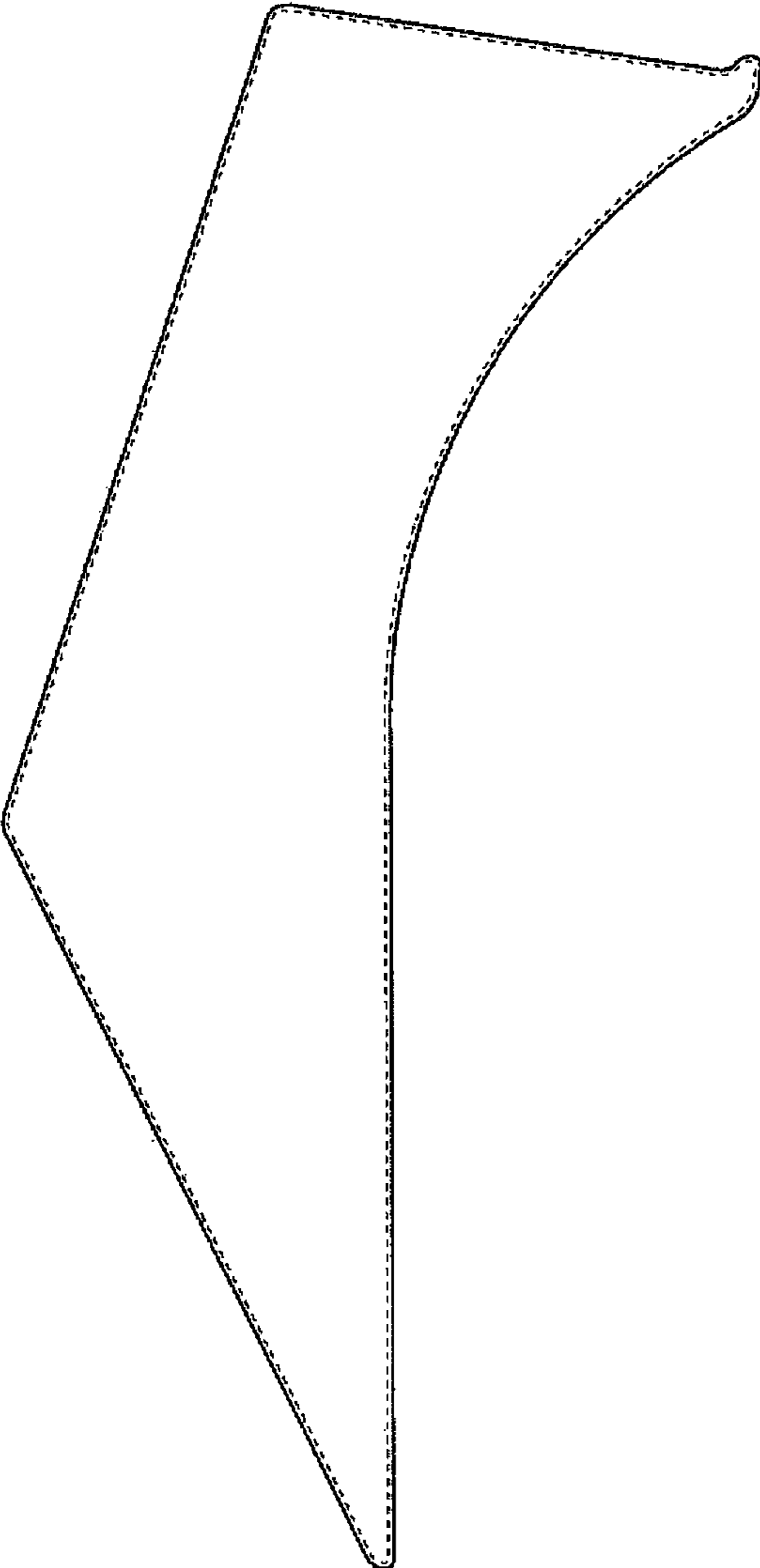

Fig. 10

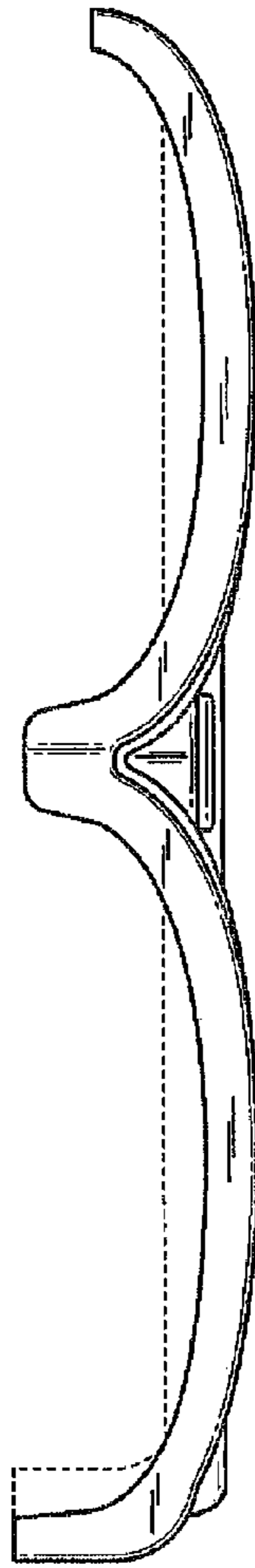

Fig. 11

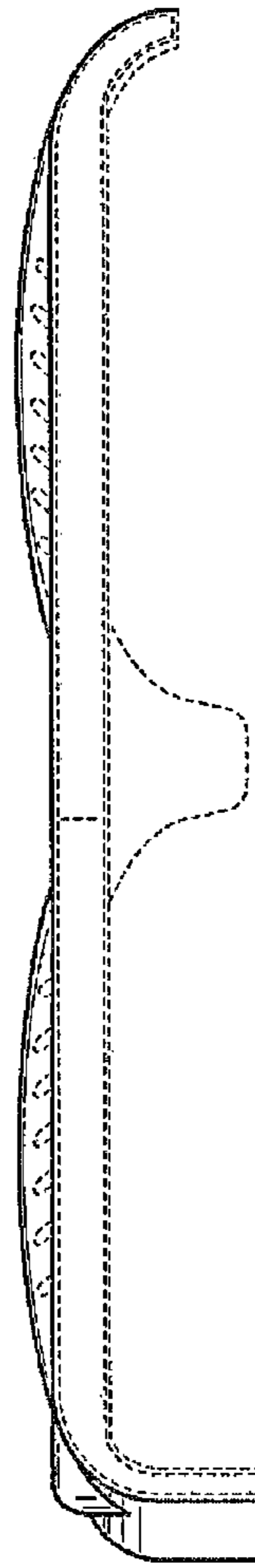

Fig. 12

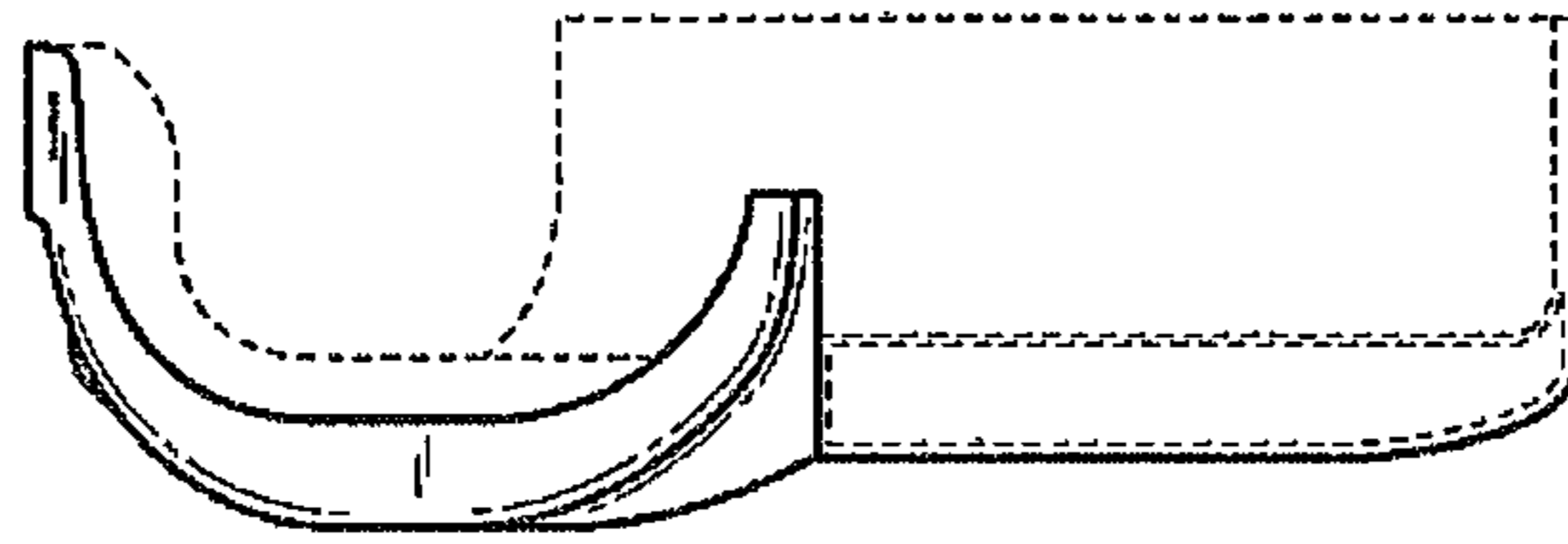

Fig. 14

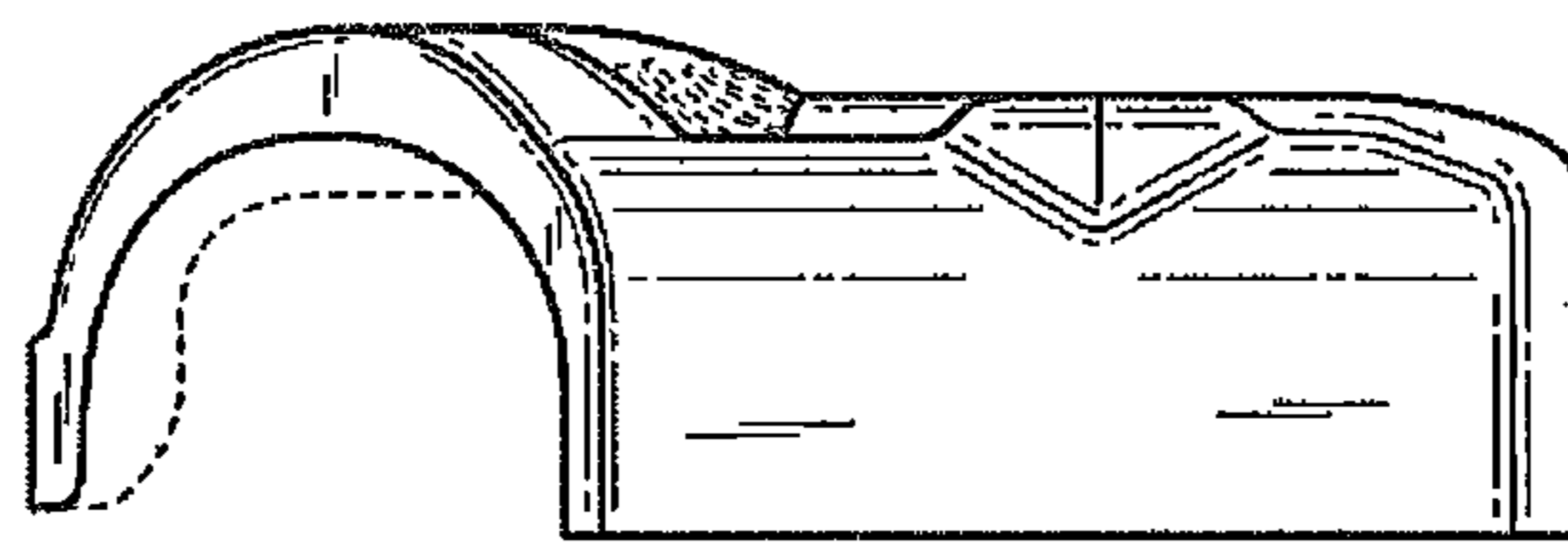

Fig. 13