



US00D685679S

(12) **United States Design Patent**
Van Braeckel

(10) **Patent No.:** **US D685,679 S**
(45) **Date of Patent:** **** Jul. 9, 2013**

(54) **MOTOR VEHICLE**

(75) Inventor: **Dirk Van Braeckel**, Chester (GB)

(73) Assignee: **Bentley Motors Limited** (GB)

(**) Term: **14 Years**

(21) Appl. No.: **29/413,963**

(22) Filed: **Feb. 23, 2012**

(30) **Foreign Application Priority Data**

Aug. 23, 2011 (EP) 001907098

(51) **LOC (9) Cl.** **12-08**

(52) **U.S. Cl.**
USPC **D12/92**

(58) **Field of Classification Search**
USPC D12/86, 90-92, 88; D21/424, 433,
D21/434; 296/181.1, 181.5
See application file for complete search history.

(56) **References Cited**

U.S. PATENT DOCUMENTS

D558,642 S *	1/2008	van Braeckel	D12/92
D574,752 S *	8/2008	van Braeckel	D12/92
D658,545 S *	5/2012	Van Braeckel	D12/91
D669,394 S *	10/2012	Hall et al.	D12/92
D669,819 S *	10/2012	Hall et al.	D12/92

* cited by examiner

Primary Examiner — Melody Brown

(74) *Attorney, Agent, or Firm* — Salter & Michaelson

(57) **CLAIM**

The ornamental design for a motor vehicle, as shown and described.

DESCRIPTION

FIG. 1 is a front perspective view of a motor vehicle;
 FIG. 2 is a front elevational view thereof;
 FIG. 3 is a rear elevational view thereof;
 FIG. 4 is a top plan view thereof;
 FIG. 5 is a left side elevational view thereof;
 FIG. 6 is a right side elevational view thereof;
 FIG. 7 is a rear perspective view thereof;
 FIG. 8 is a perspective view of a second embodiment of the motor vehicle;
 FIG. 9 is a front elevational view of a second embodiment thereof;
 FIG. 10 is a rear elevational view of a second embodiment thereof;
 FIG. 11 is a top plan view of a second embodiment thereof;
 FIG. 12 is a left side elevational view of a second embodiment thereof;
 FIG. 13 is a right side elevational view of a second embodiment thereof; and,
 FIG. 14 is a rear perspective view of a second embodiment thereof.

The portions shown in broken lines are included for illustrative purposes only and form no part of the claimed design.

1 Claim, 14 Drawing Sheets

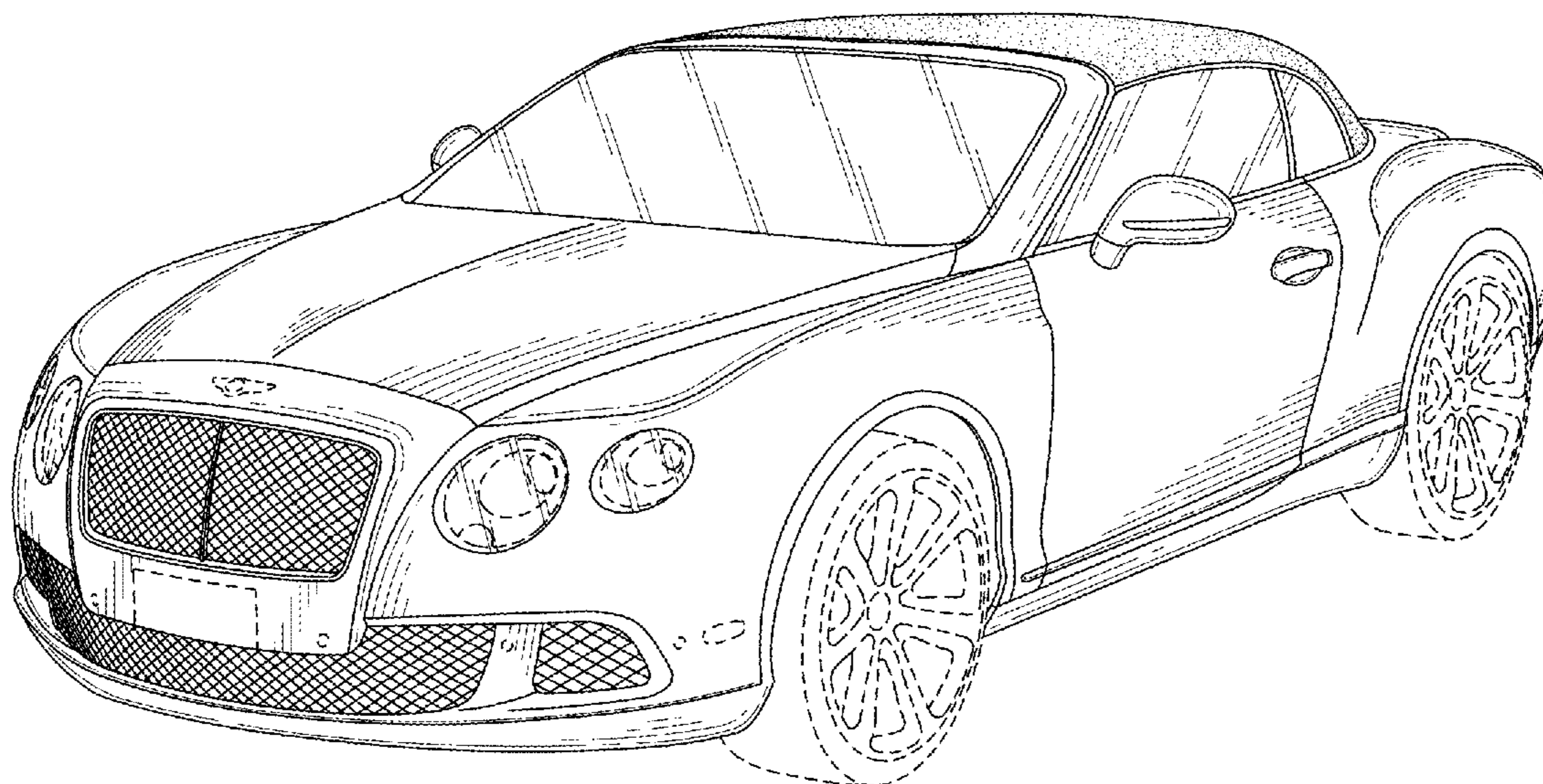

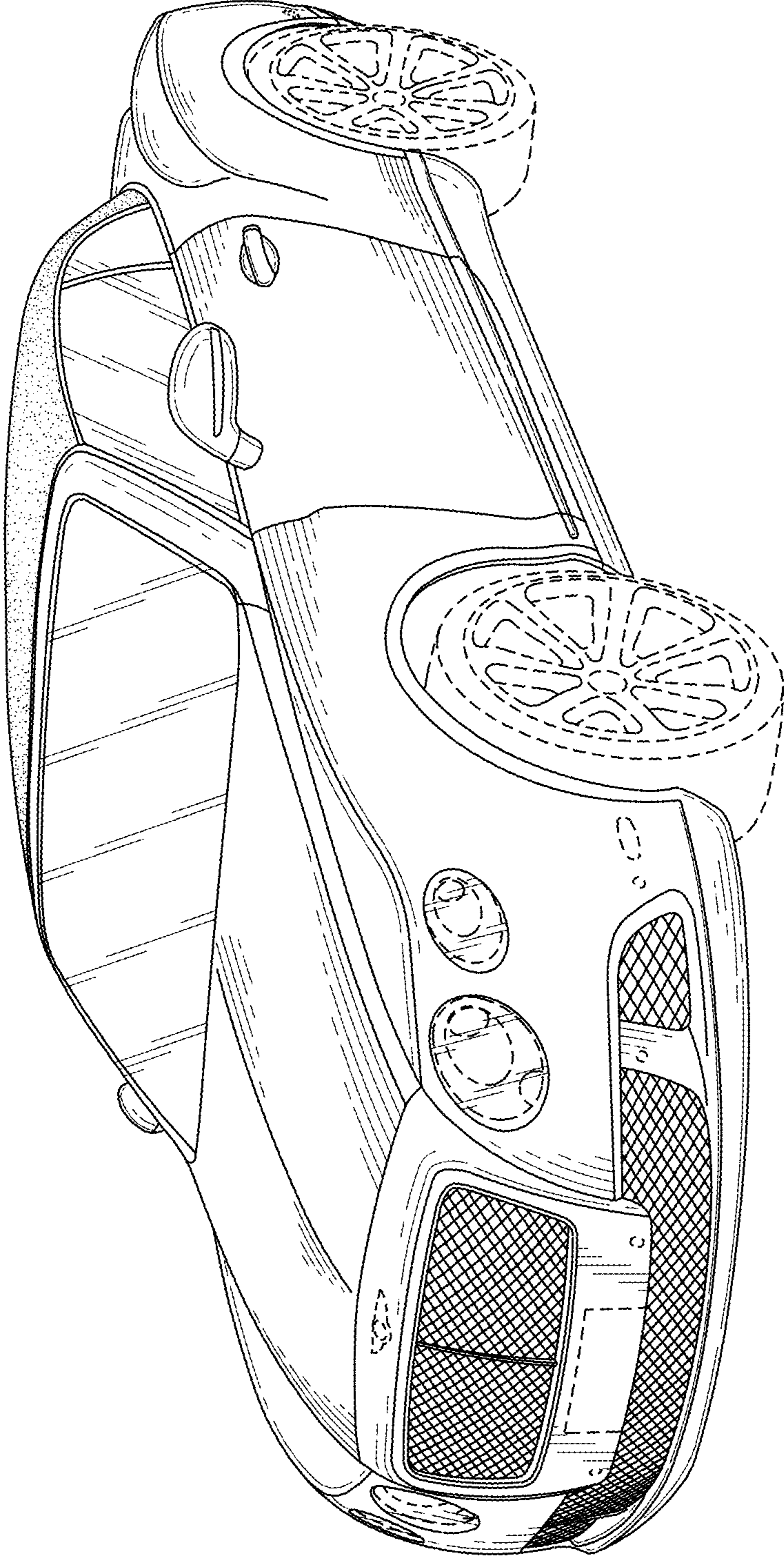

FIG. 1

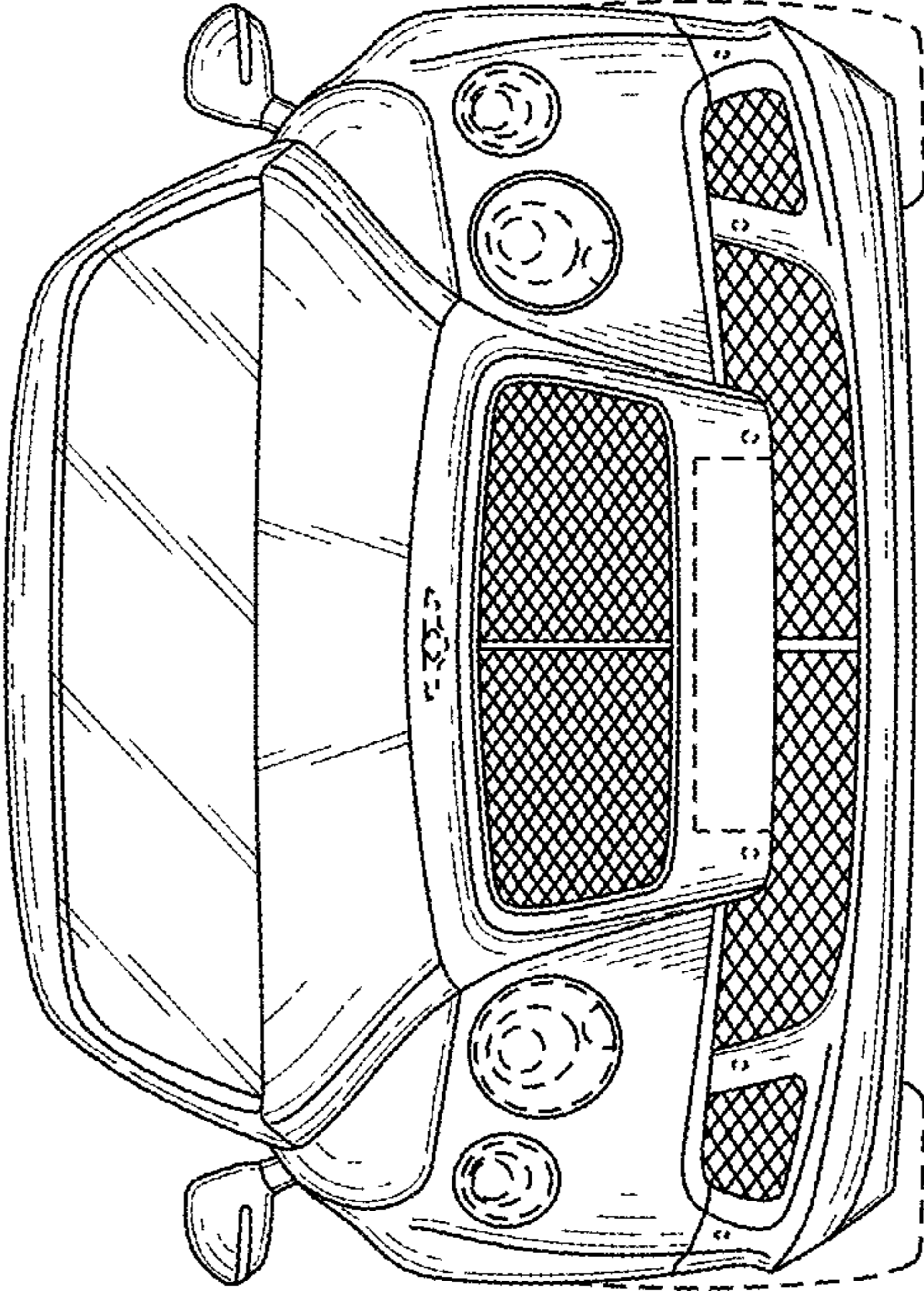

FIG. 2

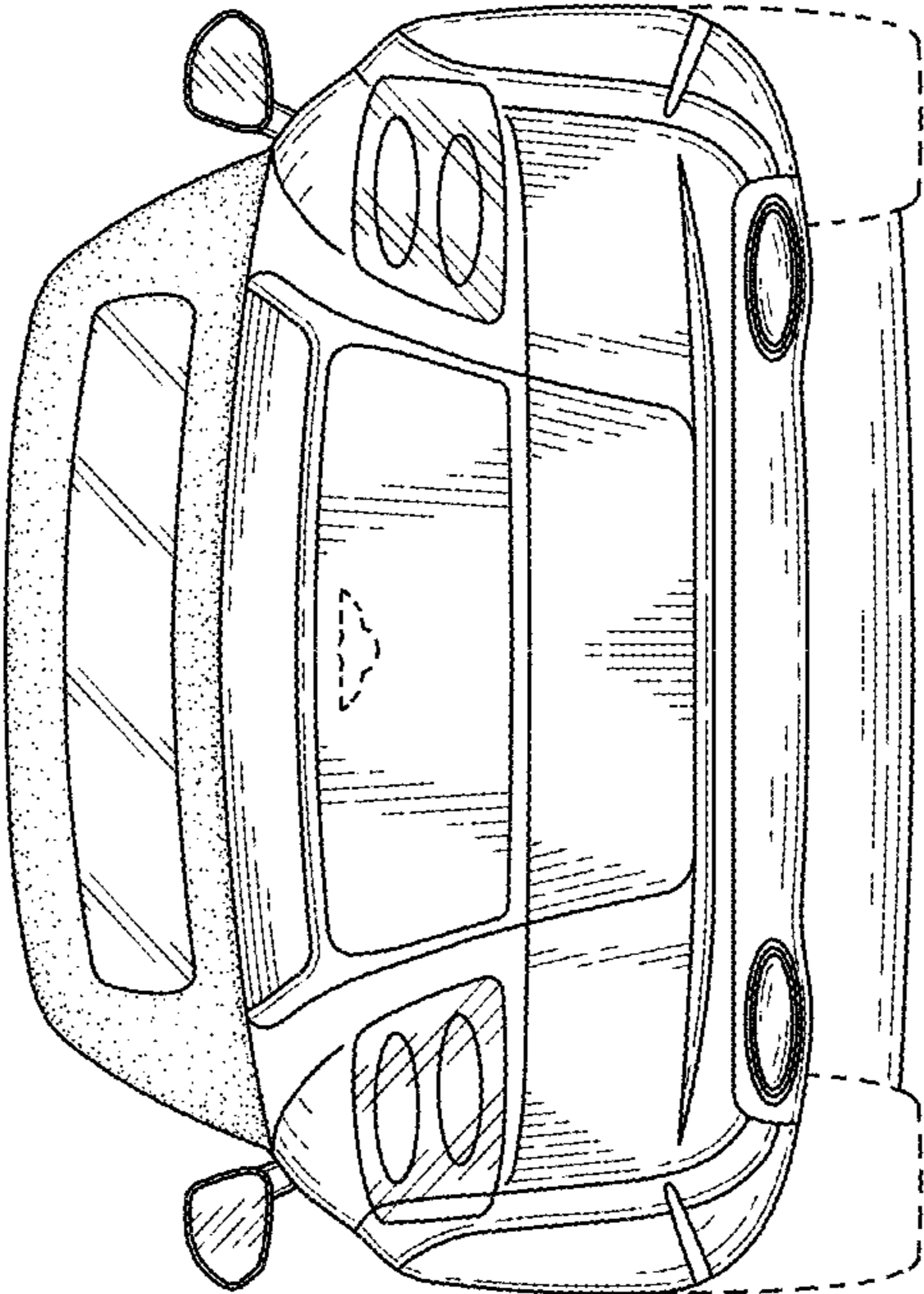

FIG. 3

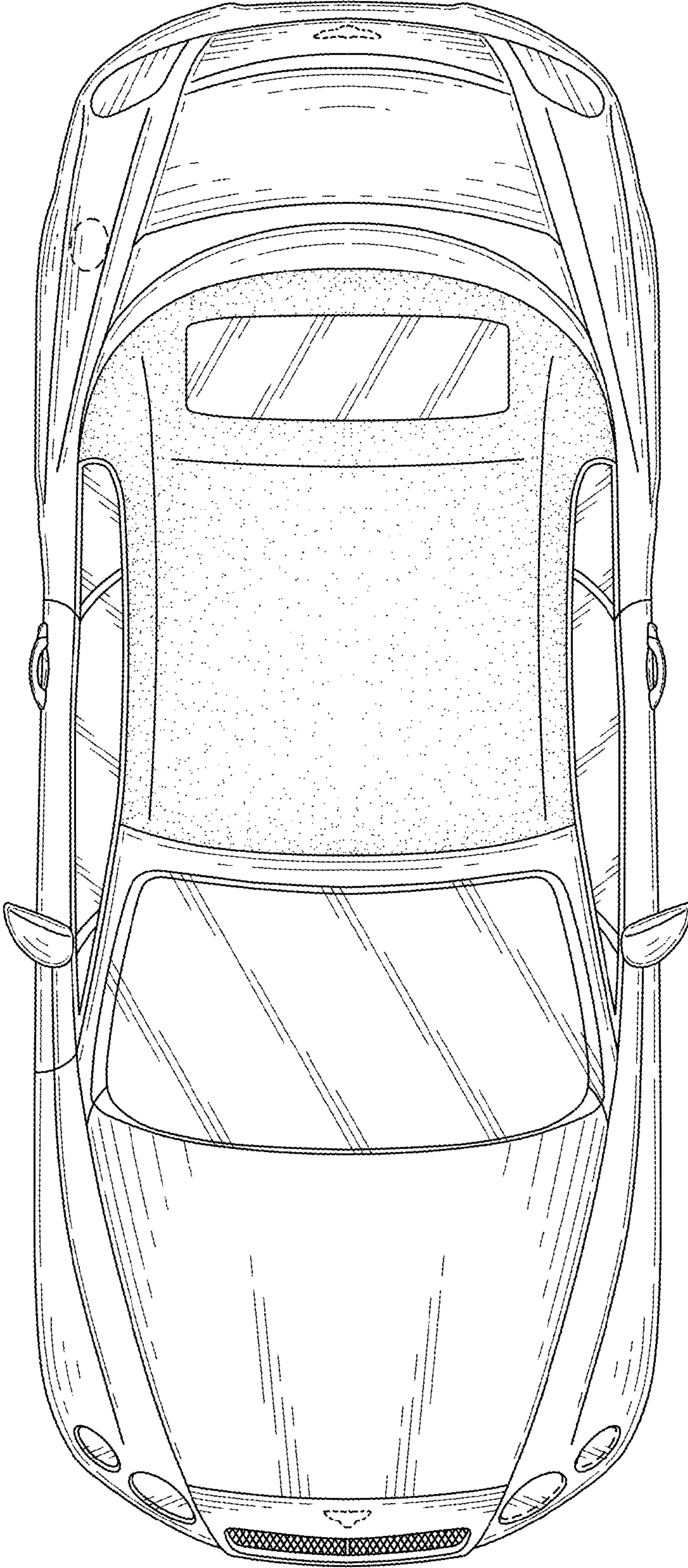

FIG. 4

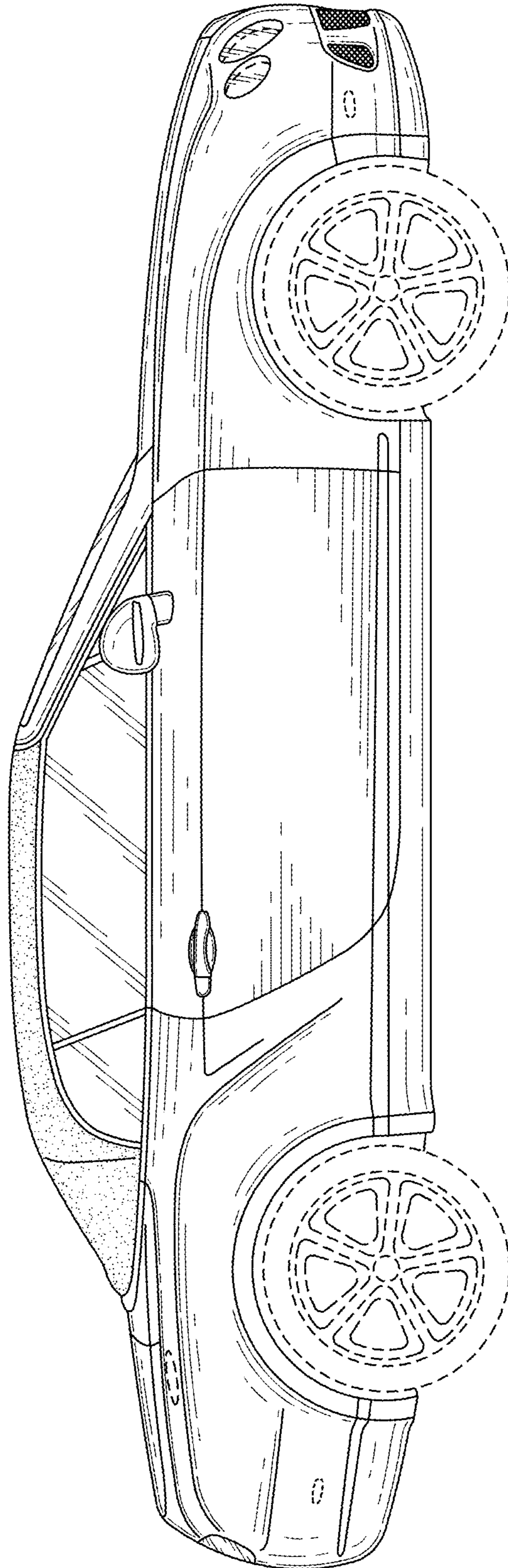

FIG. 5

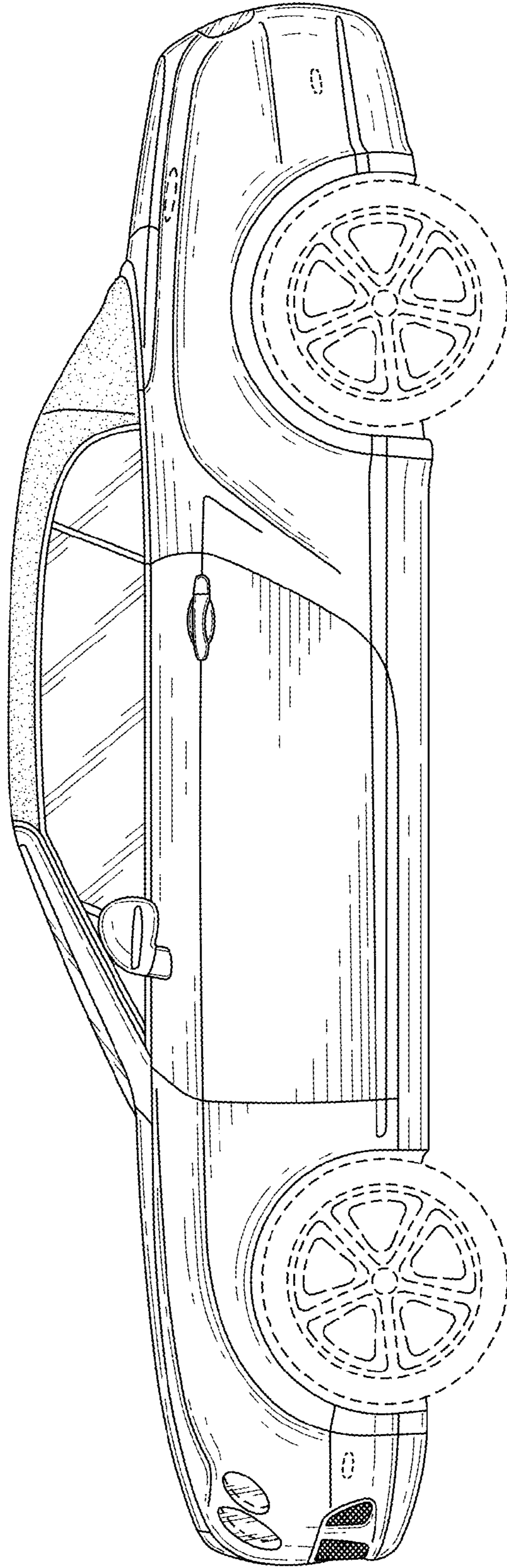

FIG. 6

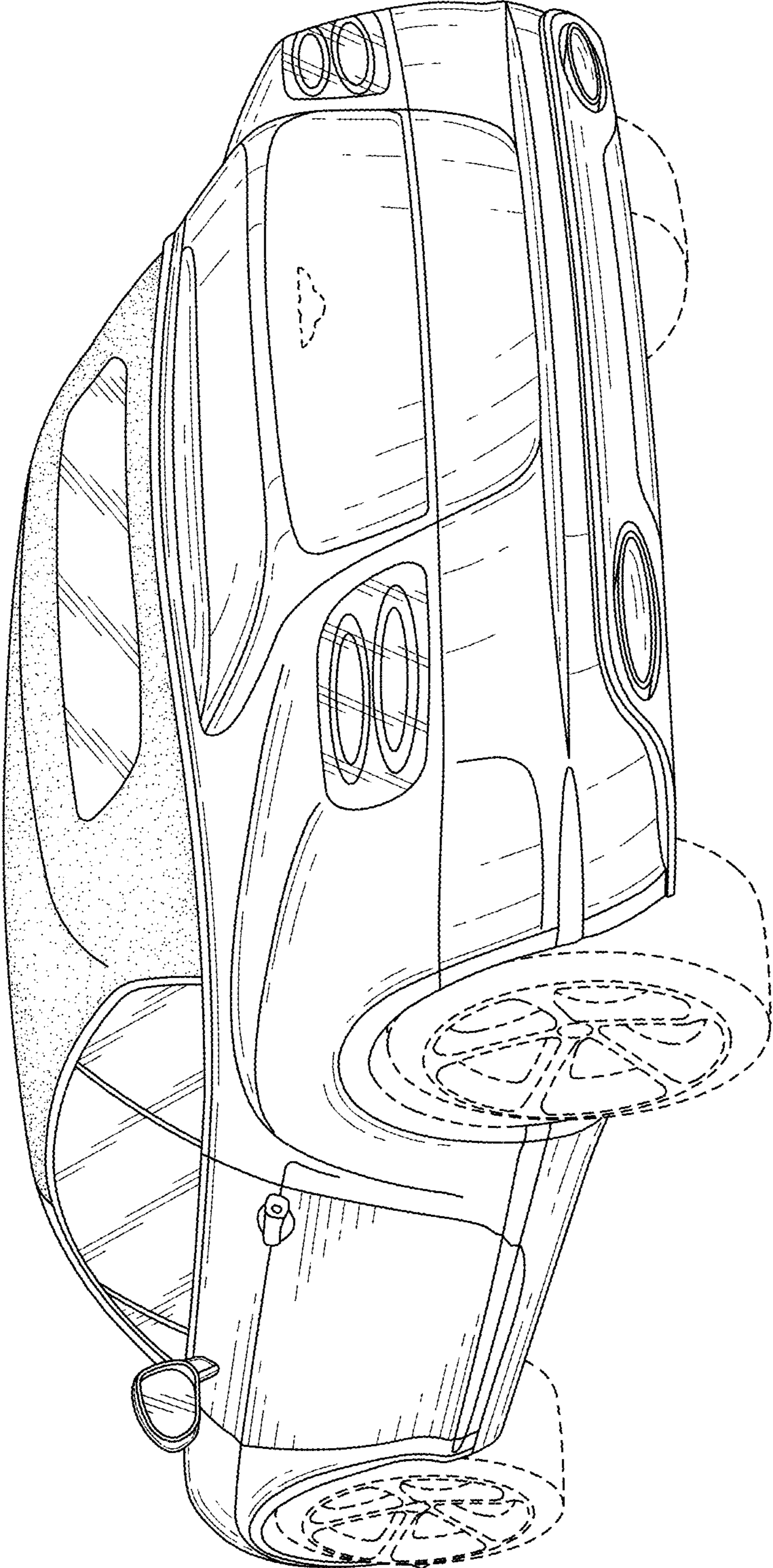

FIG. 7

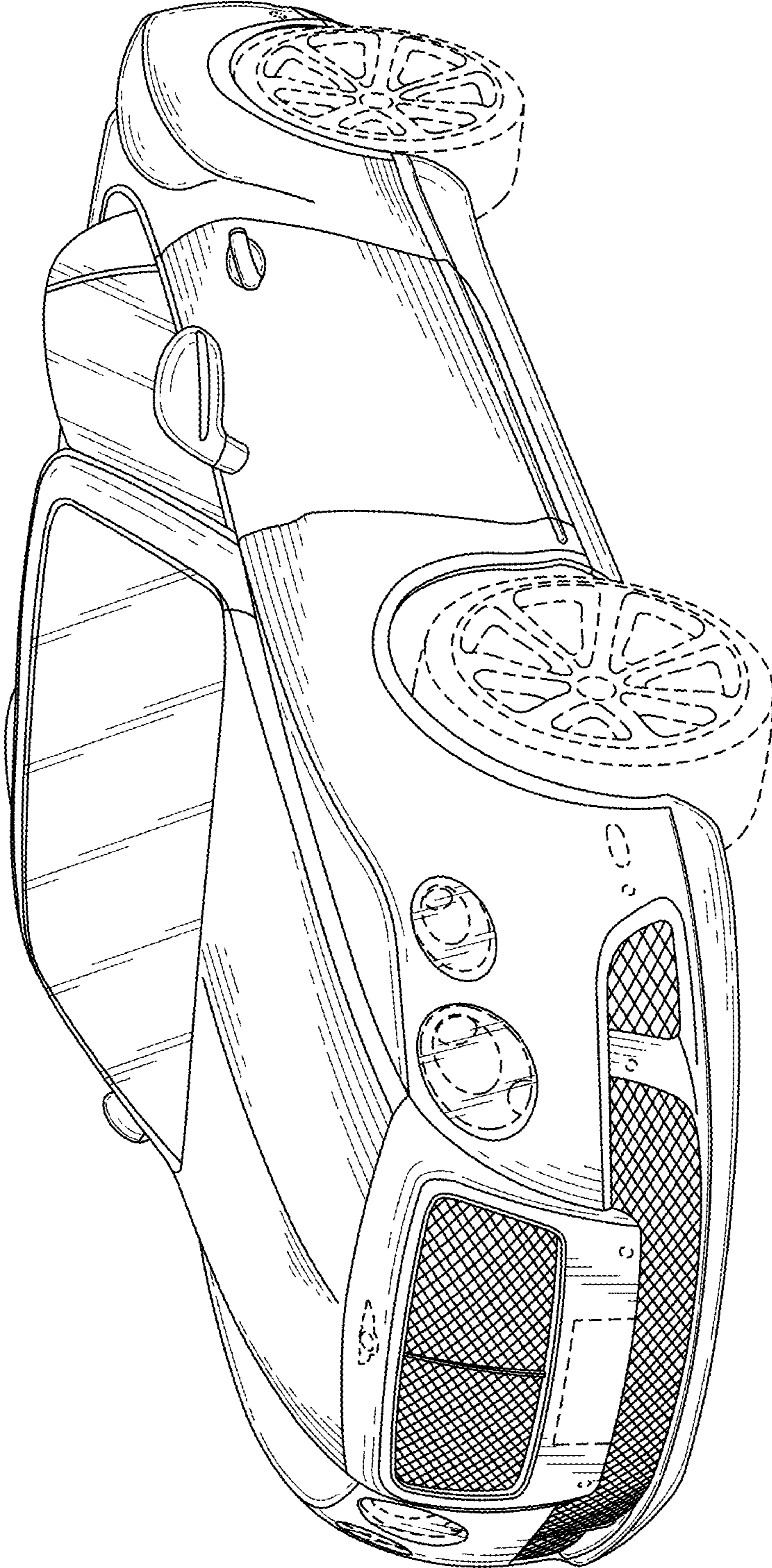

FIG. 8

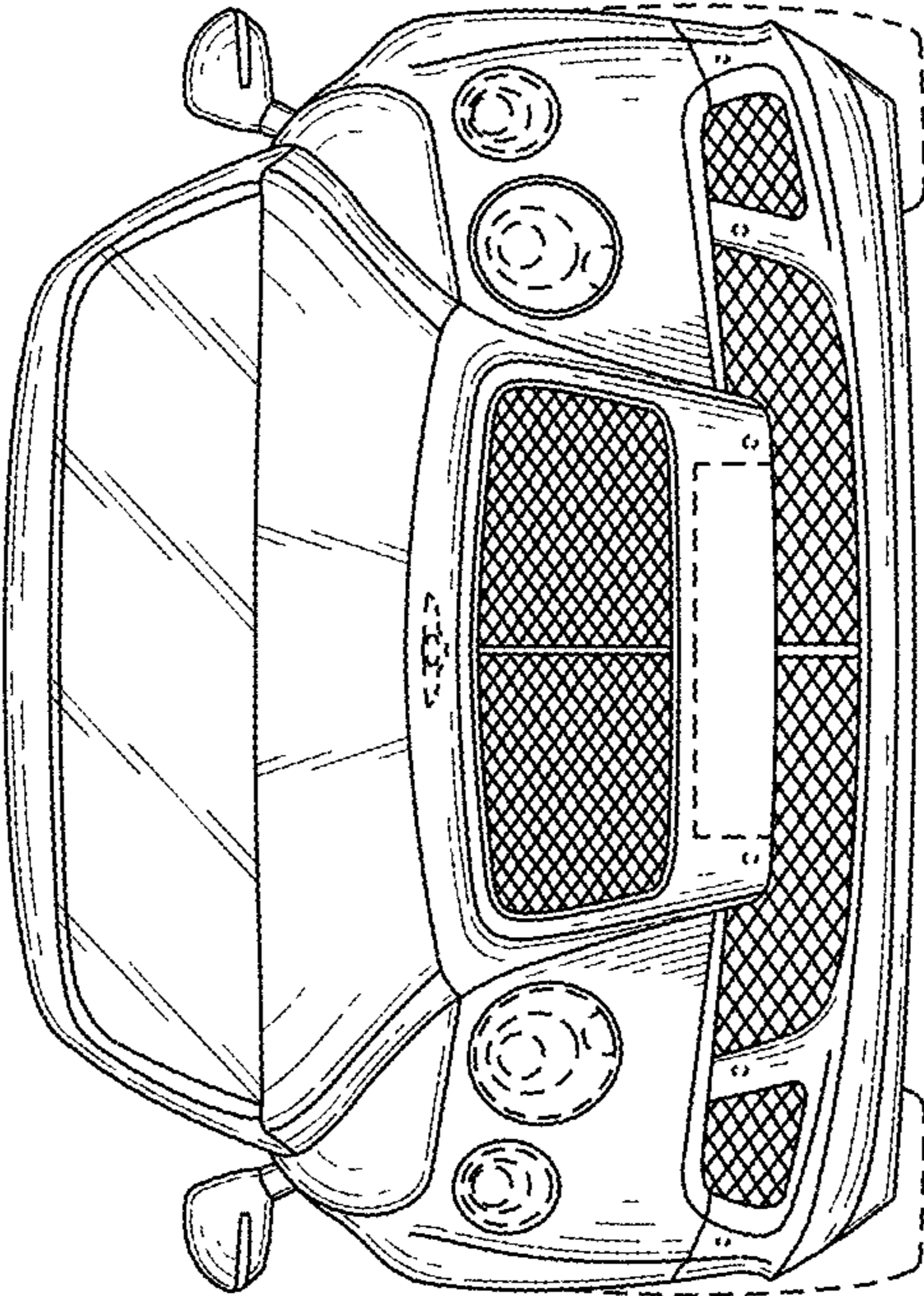

FIG. 9

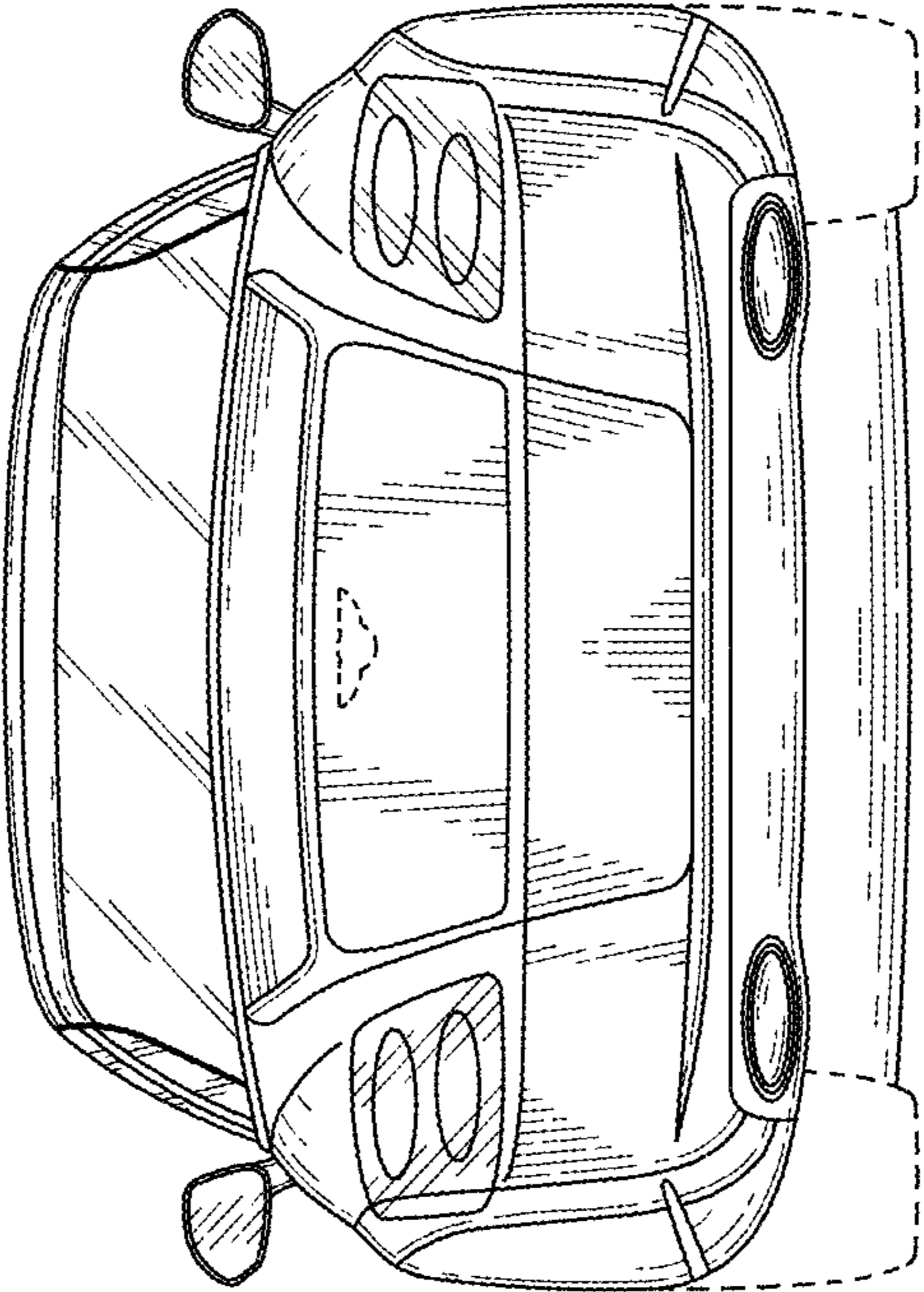

FIG. 10

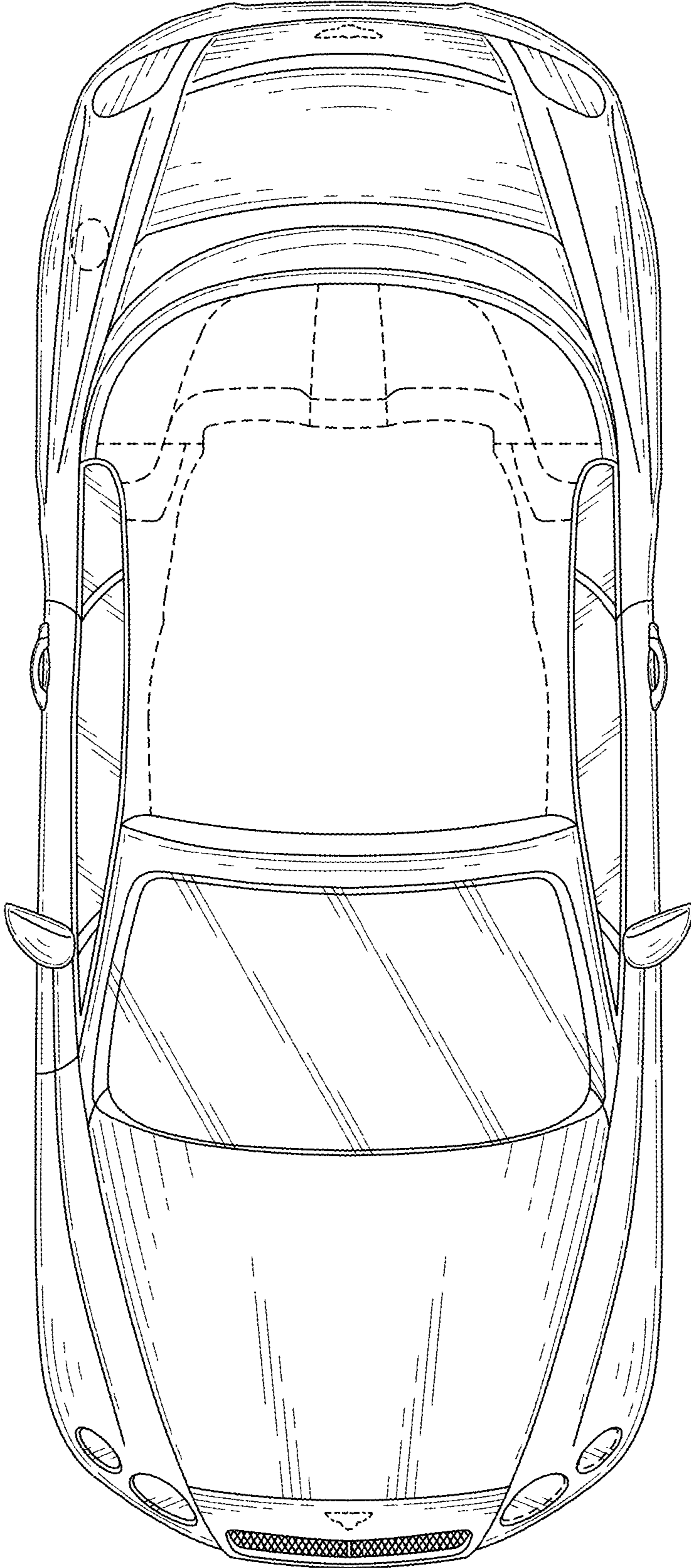

FIG. 11

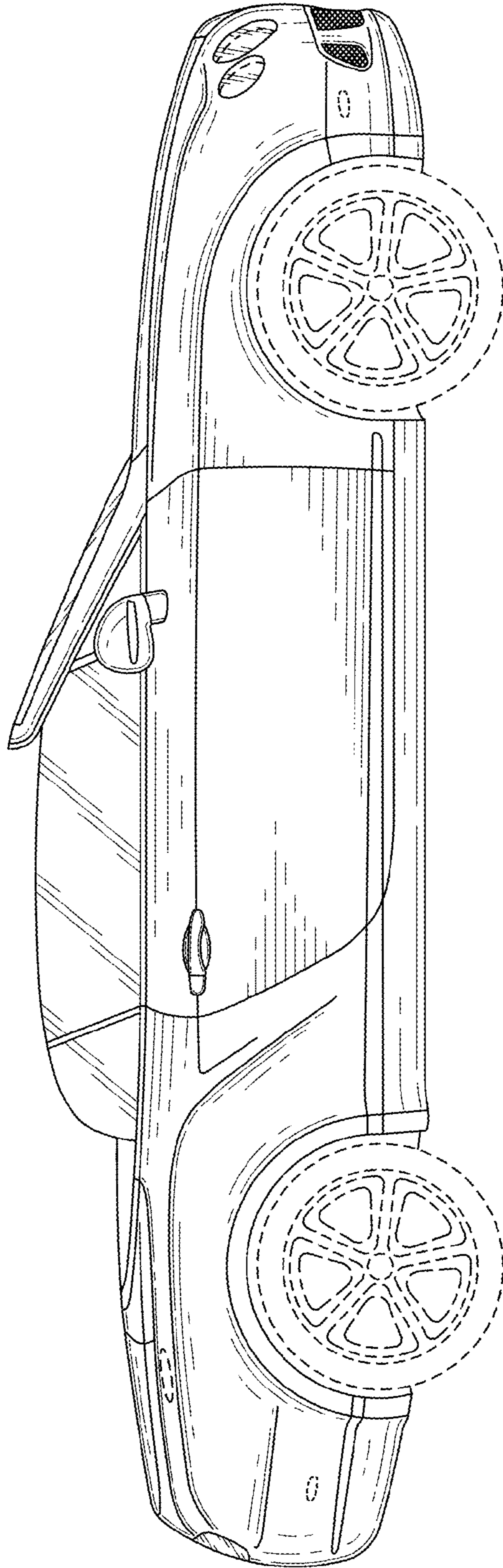

FIG. 12

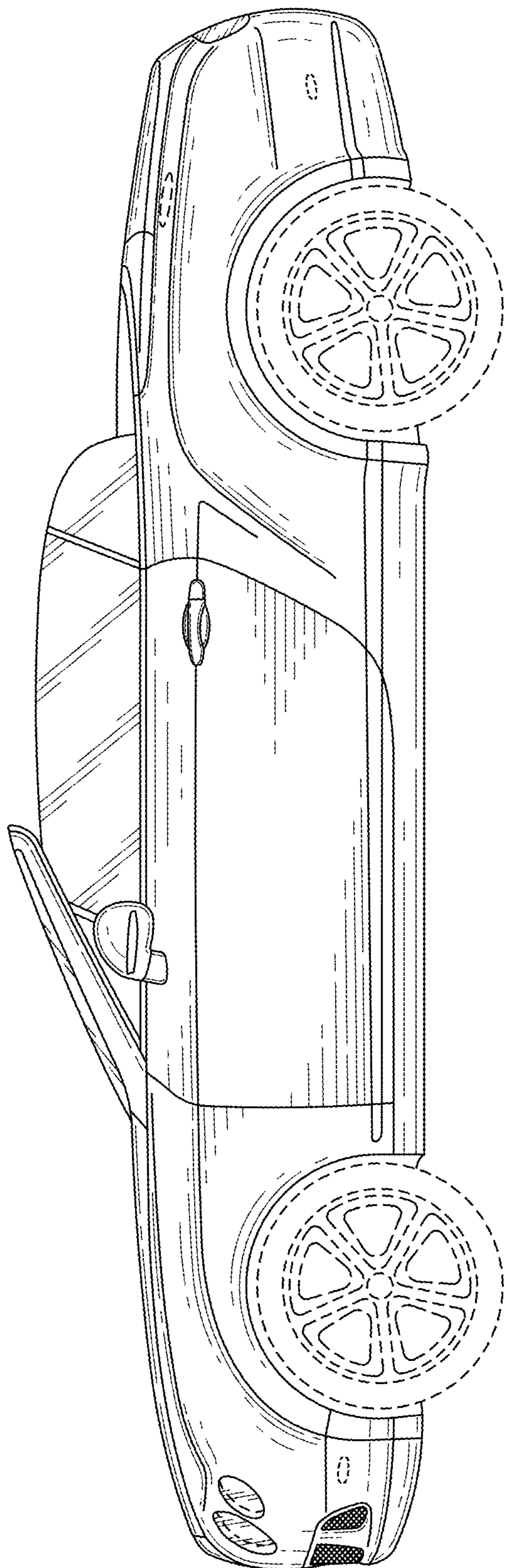

FIG. 13

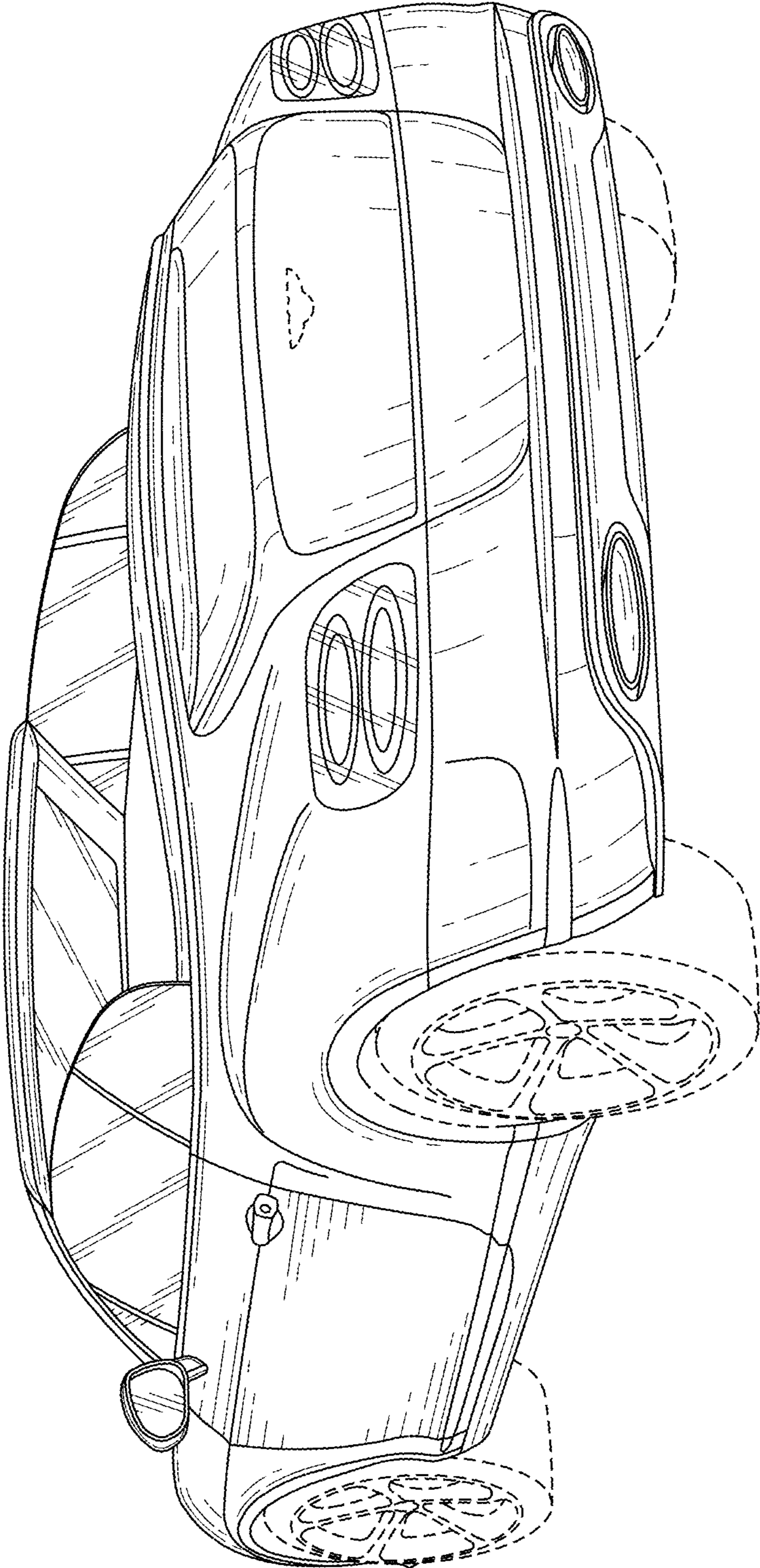

FIG. 14