



US00D685563S

(12) **United States Design Patent**  
**Chan**

(10) **Patent No.:** **US D685,563 S**

(45) **Date of Patent:** **\*\* Jul. 2, 2013**

(54) **SCISSOR TYPE AUTOMOTIVE LIFT**

(75) Inventor: **Desmond Chan**, Richmond (CA)

(73) Assignee: **668201 B.C. Ltd**, Richmond, B.C. (CA)

(\*\*) Term: **14 Years**

(21) Appl. No.: **29/403,265**

(22) Filed: **Oct. 4, 2011**

(51) **LOC (9) Cl.** ..... **12-05**

(52) **U.S. Cl.**  
USPC ..... **D34/28**

(58) **Field of Classification Search**  
USPC ..... D34/28, 33, 31; 254/88, 122, 124,  
254/93 H, 93 R, 93 I, 93 VA  
See application file for complete search history.

(56) **References Cited**

U.S. PATENT DOCUMENTS

3,220,585	A *	11/1965	McCartney et al.	.....	414/659
3,259,369	A *	7/1966	Gridley	.....	254/122
4,180,252	A *	12/1979	Cushenbery	.....	269/17
D302,893	S *	8/1989	Wakefield	.....	D34/31

4,867,277	A *	9/1989	Sloan	.....	187/243
5,105,915	A *	4/1992	Gary	.....	187/200
5,379,855	A *	1/1995	Juang	.....	187/269
5,503,368	A *	4/1996	Torres	.....	254/88
6,854,715	B2 *	2/2005	Hicks et al.	.....	254/122
D647,680	S *	10/2011	Fukuma et al.	.....	D34/28

\* cited by examiner

*Primary Examiner* — Cynthia Ramirez

(57) **CLAIM**

I claim the ornamental design for a scissor type automotive lift, as shown and described.

**DESCRIPTION**

FIG. 1 is a front right perspective view of a scissor type automotive lift in the extended position, showing our new design;  
FIG. 2 is a side plan view thereof;  
FIG. 3 is a front plan view thereof;  
FIG. 4 is a rear plan view thereof;  
FIG. 5 is top right perspective view thereof; and,  
FIG. 6 is a front left perspective view thereof.  
The bottom of the lift is not part of the claim design.

**1 Claim, 6 Drawing Sheets**

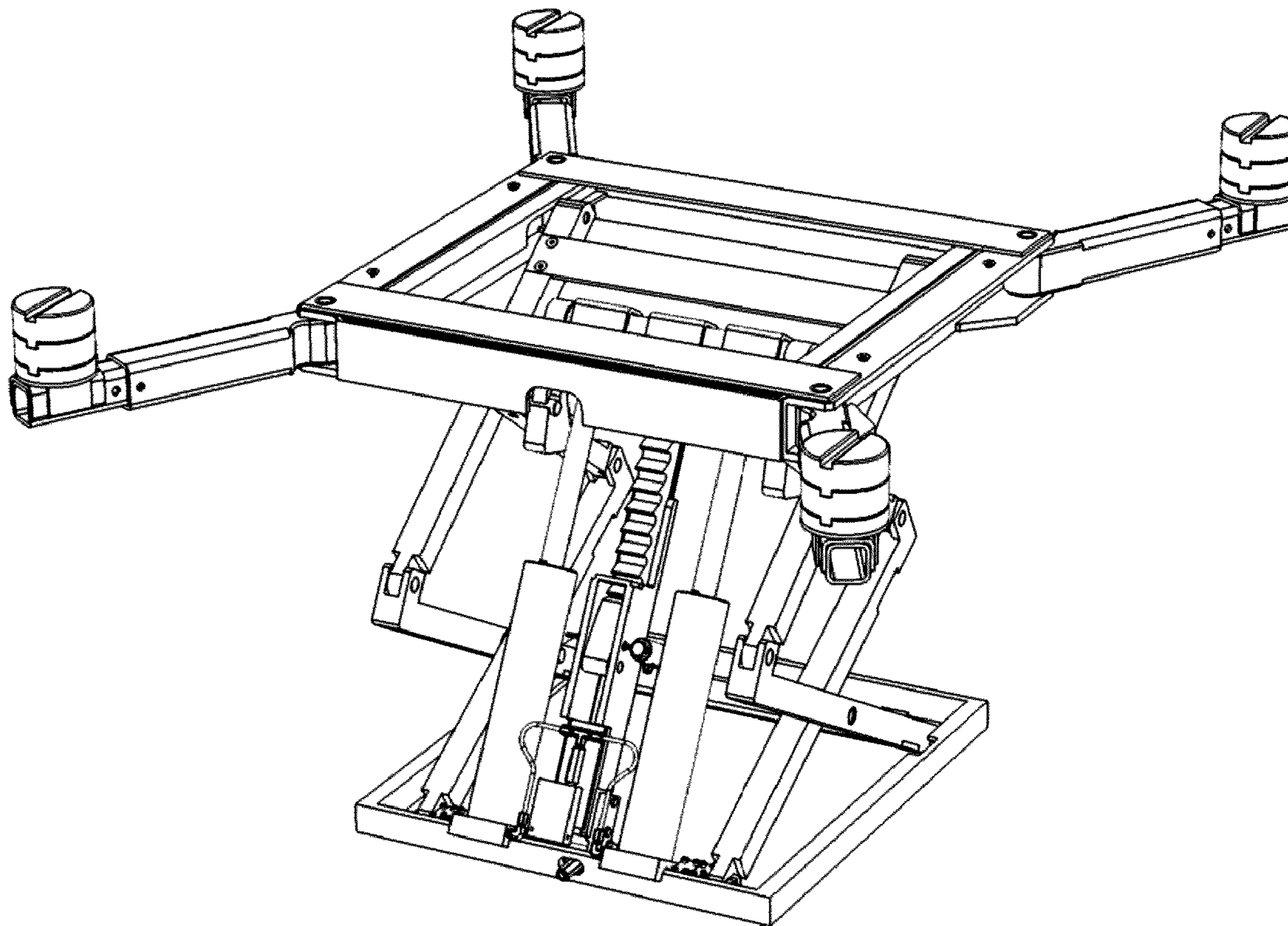

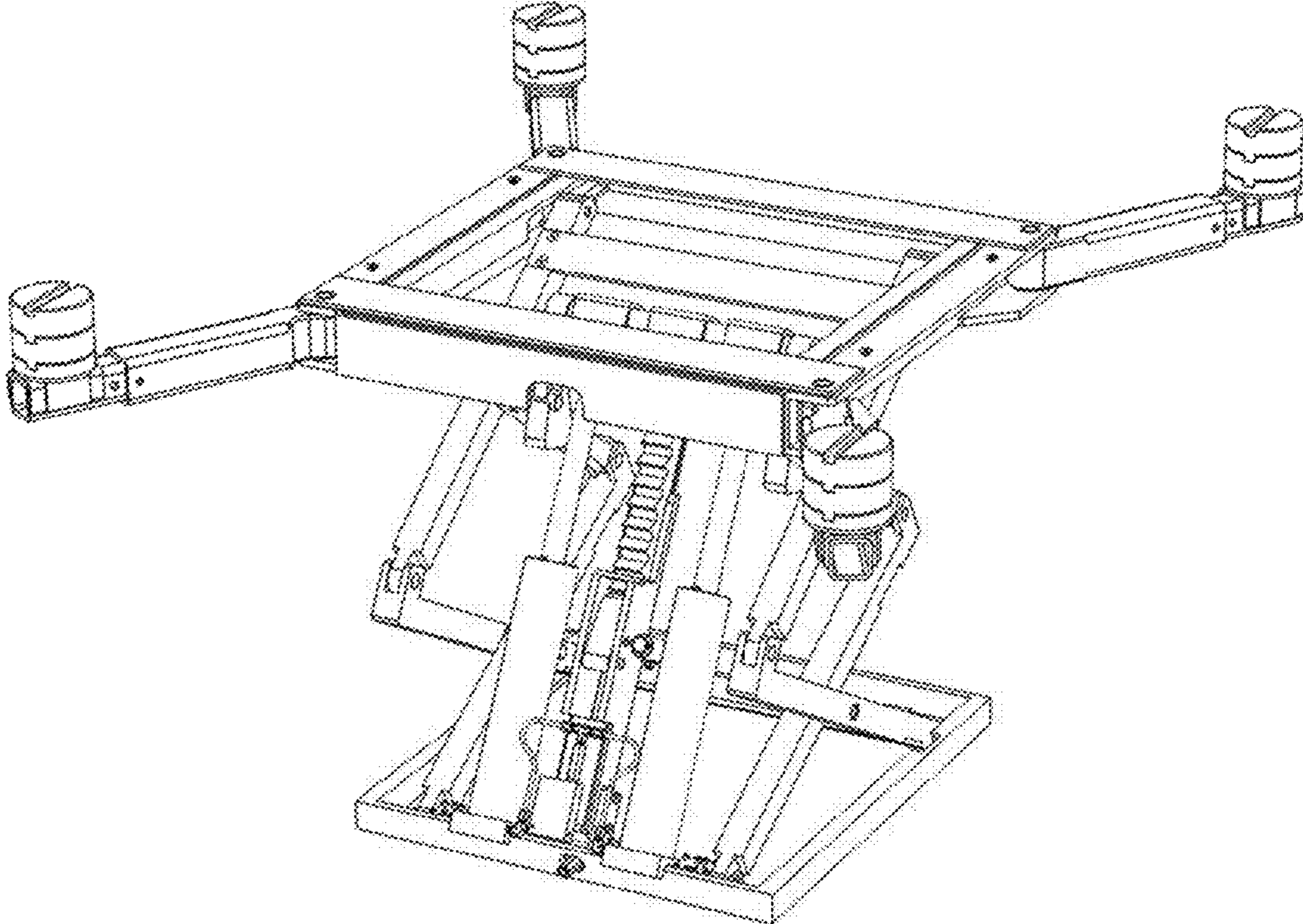

FIG. 1

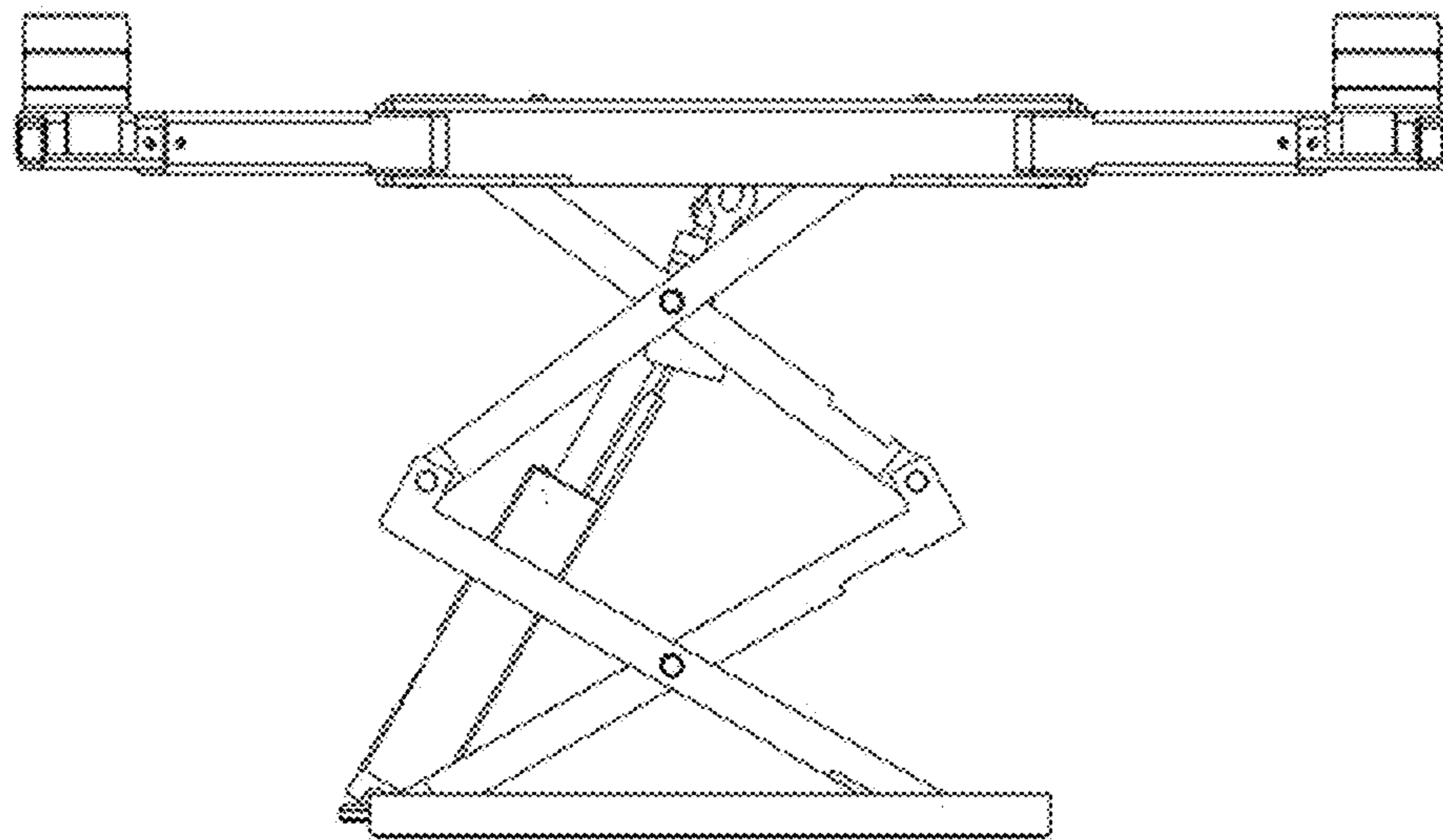

FIG. 2

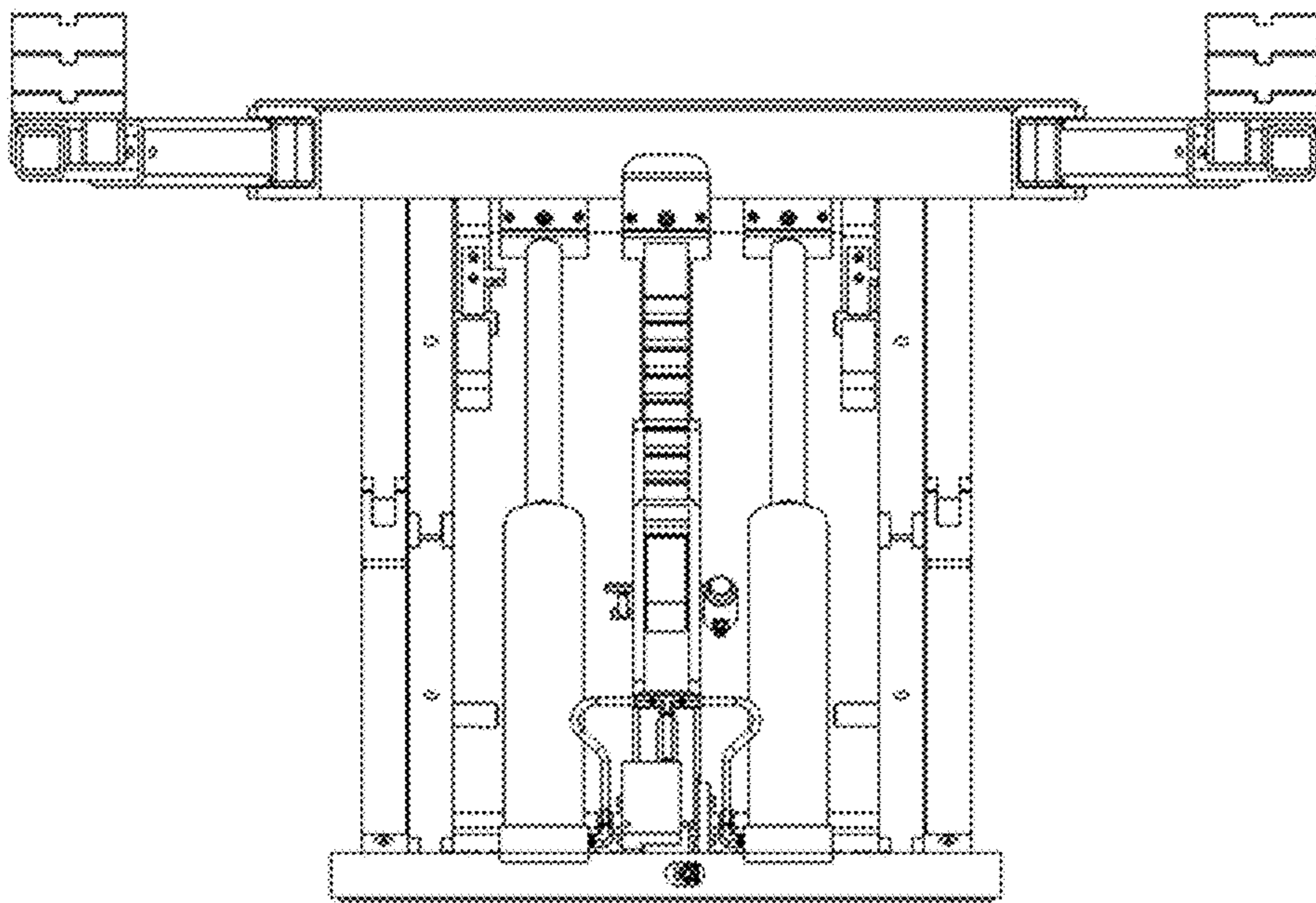

FIG. 3

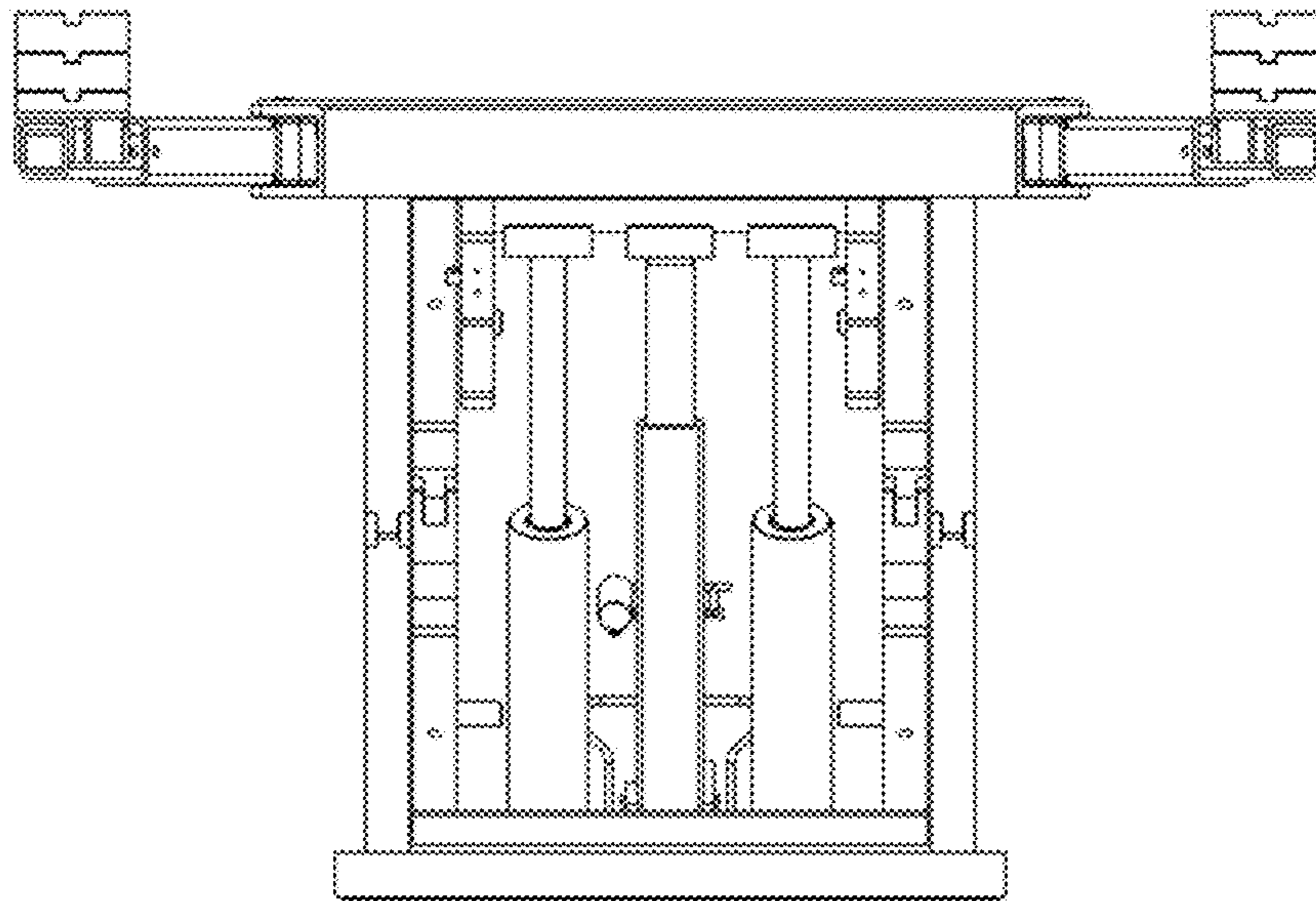

FIG. 4

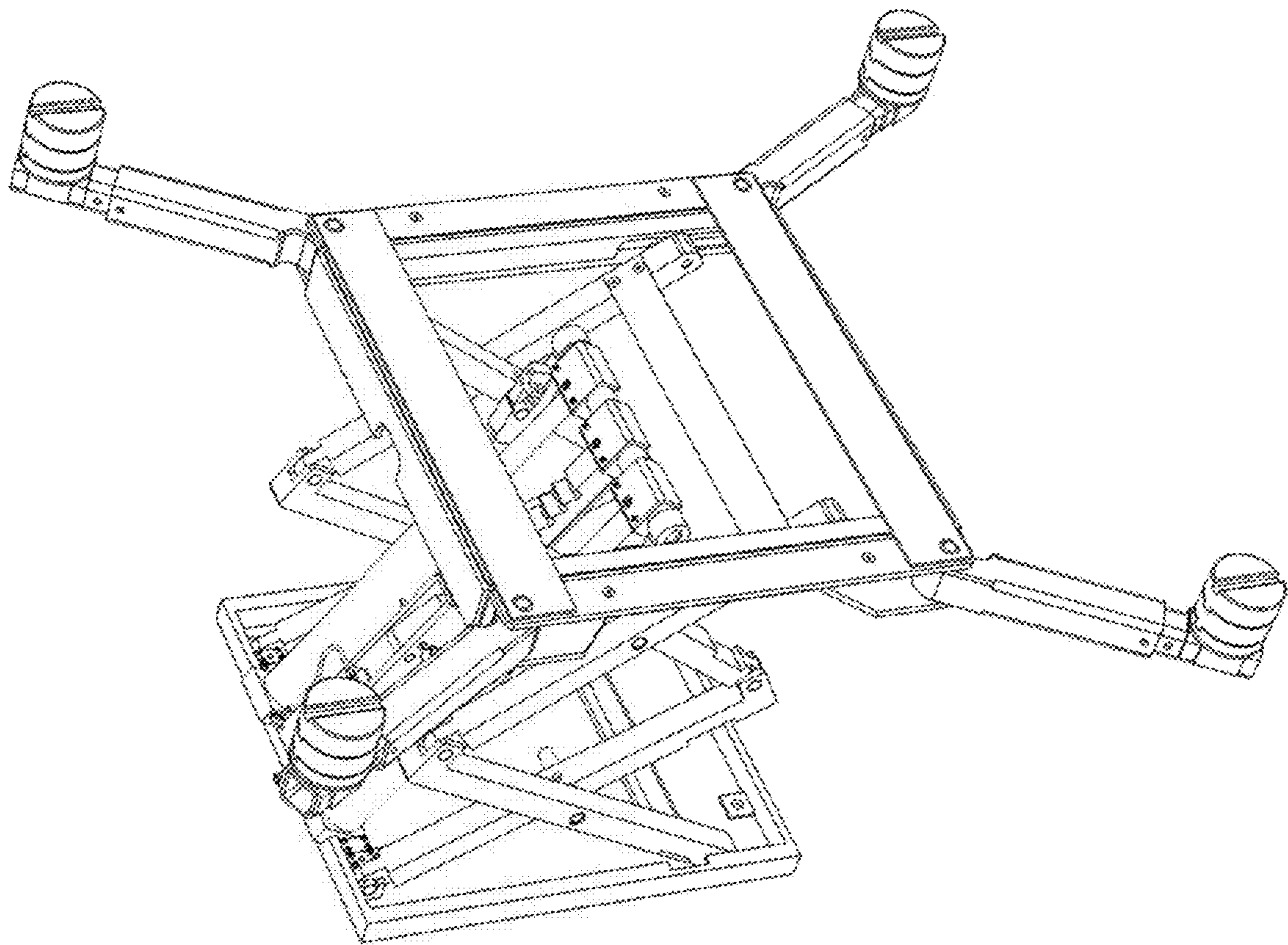

FIG. 5

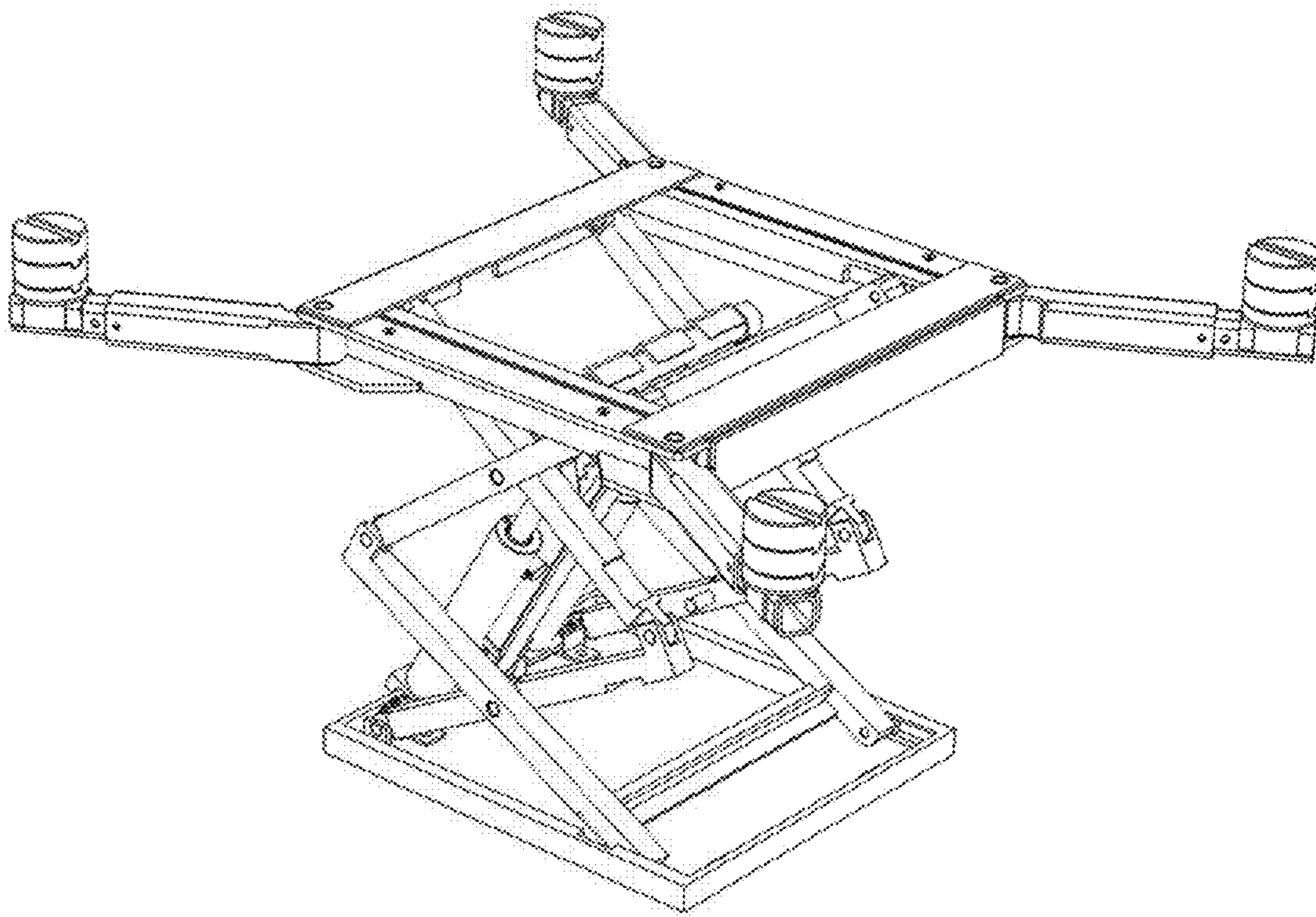

FIG. 6