



US00D685445S

(12) **United States Design Patent**
Pittman

(10) **Patent No.:** **US D685,445 S**

(45) **Date of Patent:** **** Jul. 2, 2013**

(54) **SLING ATTACHMENT DEVICE**

(75) **Inventor:** **Earl L. Pittman**, Fort Collins, CO (US)

(73) **Assignee:** **Impact Weapons Components, LLC**,
Timnath, CO (US)

(**) **Term:** **14 Years**

(21) **Appl. No.:** **29/409,482**

(22) **Filed:** **Dec. 23, 2011**

(51) **LOC (9) Cl.** **22-01**

(52) **U.S. Cl.**
USPC **D22/108**

(58) **Field of Classification Search**
USPC D22/108; 224/150, 225, 579; 42/85,
42/94; D8/356, 373
See application file for complete search history.

(56) **References Cited**

U.S. PATENT DOCUMENTS

6,263,892	B1 *	7/2001	Baker	135/66
6,536,153	B2 *	3/2003	Lindsey	42/85
6,598,330	B2 *	7/2003	Garrett et al.	42/85
D495,870	S *	9/2004	Verdugo	D3/215
7,082,709	B2 *	8/2006	Lindsey	42/85
7,841,496	B1 *	11/2010	Schweikert	224/150
7,959,046	B2 *	6/2011	Burnsed et al.	224/150

2002/0020724	A1 *	2/2002	Lindsey	224/150
2007/0257072	A1 *	11/2007	Pena et al.	224/150
2008/0217371	A1 *	9/2008	Wemmer	224/579
2011/0186603	A1 *	8/2011	Alford	224/150
2012/0255976	A1 *	10/2012	Dees	224/150

* cited by examiner

Primary Examiner — Michael A Pratt

(74) *Attorney, Agent, or Firm* — Cooley LLP

(57) **CLAIM**

The ornamental design for a sling attachment device, as shown and described.

DESCRIPTION

FIG. 1 is a perspective view thereof;
FIG. 2 is a top view thereof;
FIG. 3 is a bottom view thereof;
FIG. 4 is a front view, the back view being a mirror image thereof;
FIG. 5 is a left side view thereof; and,
FIG. 6 is a right side view thereof.
The broken lines immediately adjacent the shaded areas represent the bounds of the claimed design while all other broken lines are directed to environment and are for illustrative purposes only; the broken lines form no part of the claimed design.

1 Claim, 3 Drawing Sheets

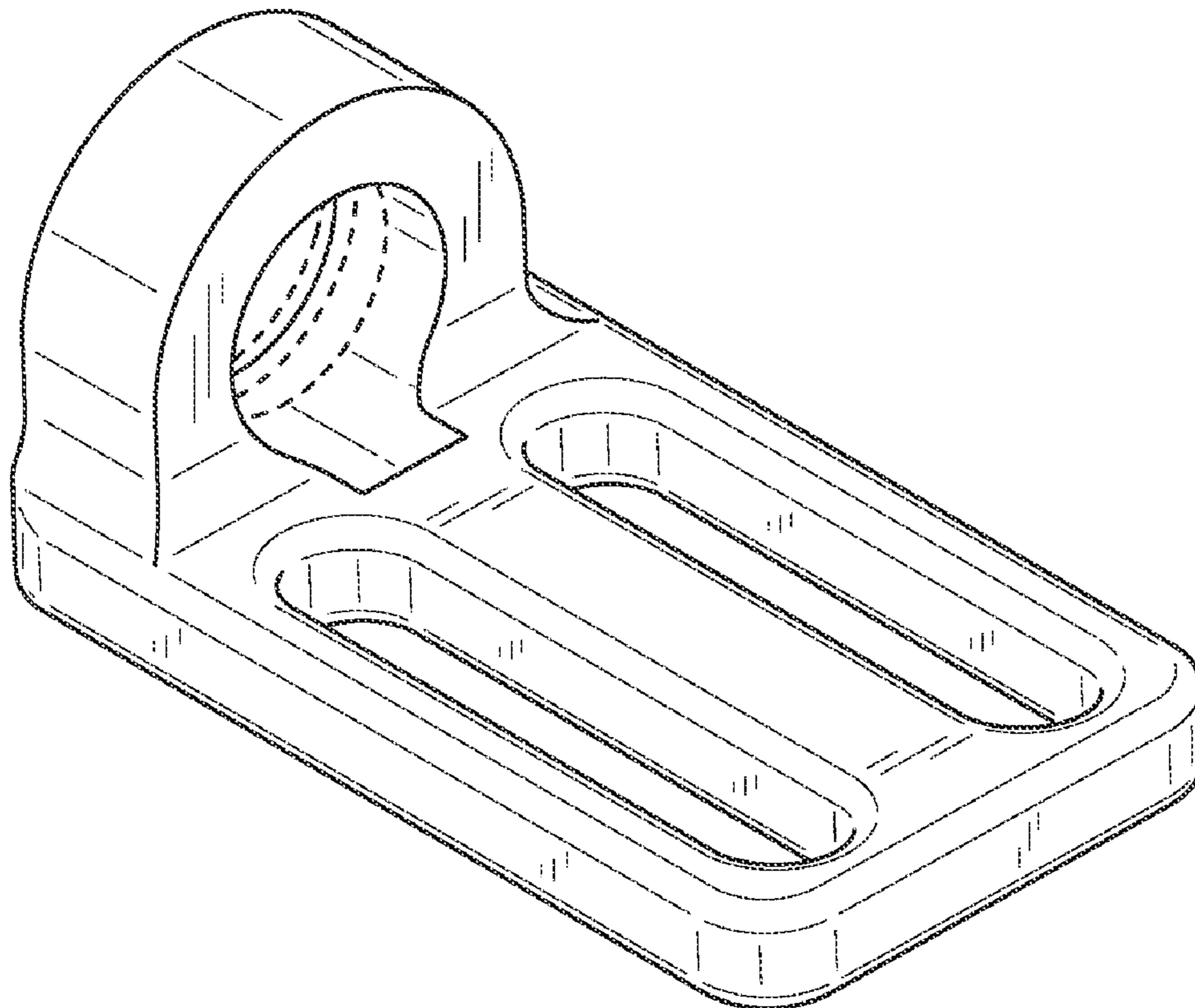

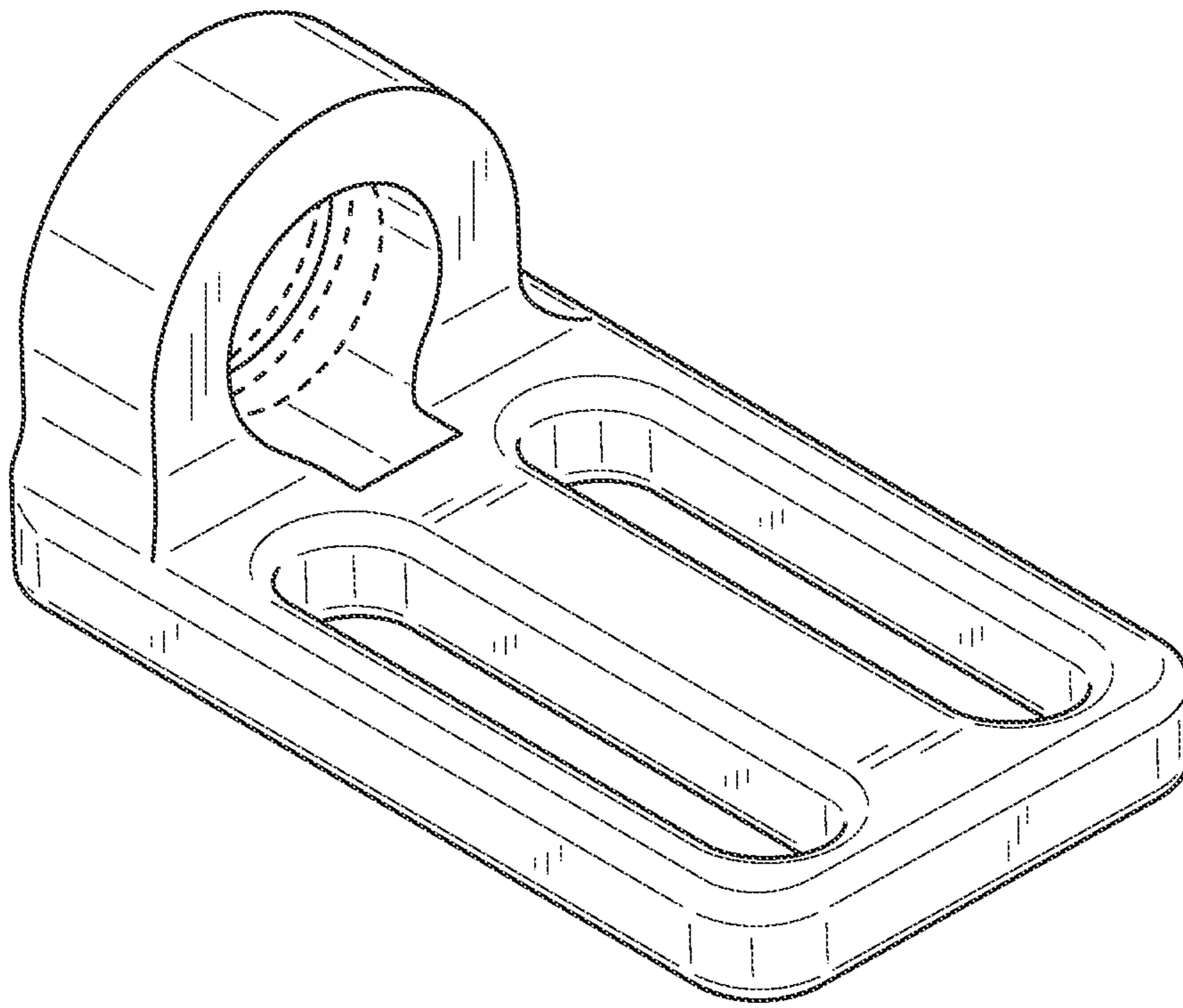

FIG.1

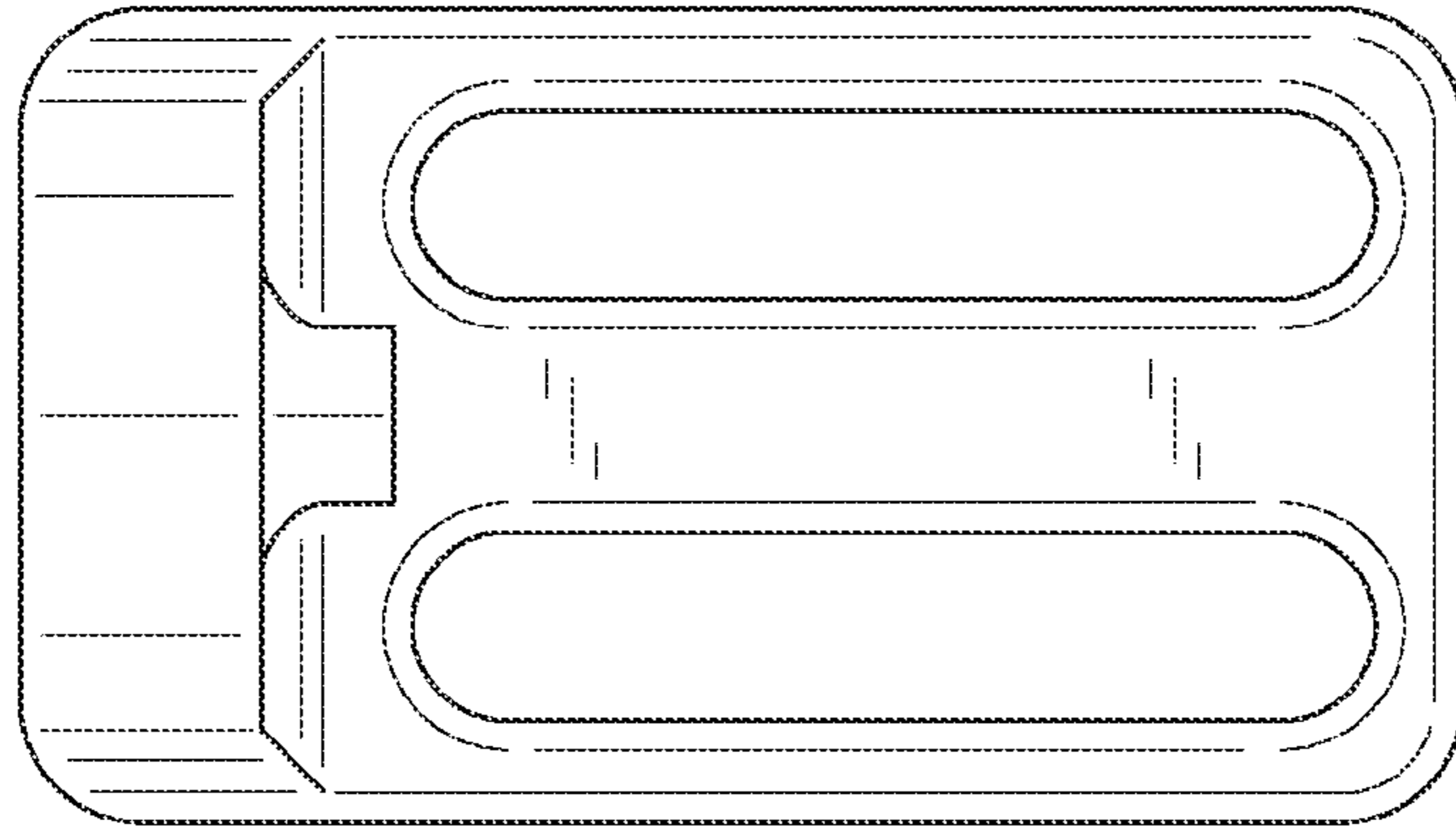

FIG. 2

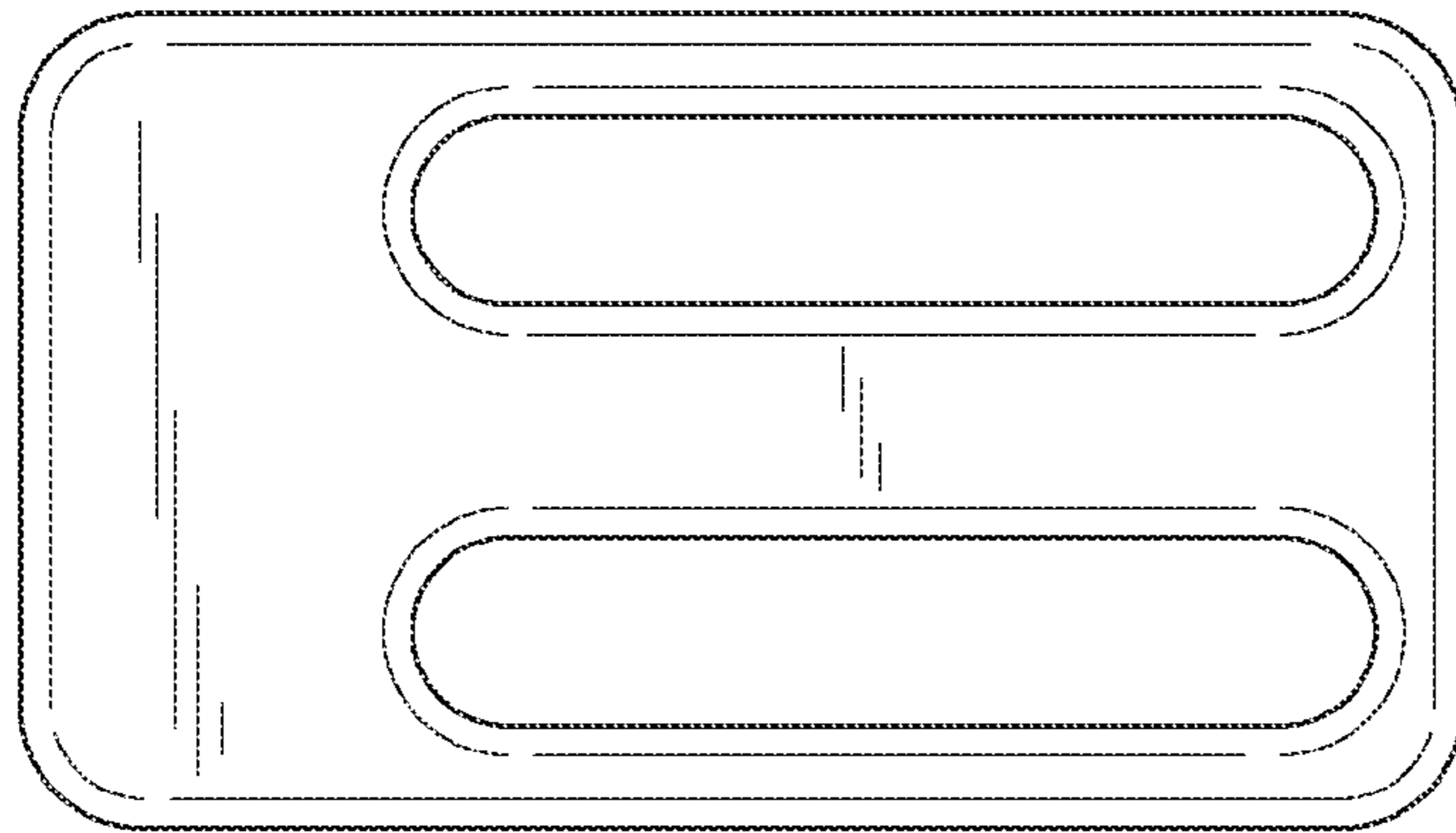

FIG. 3

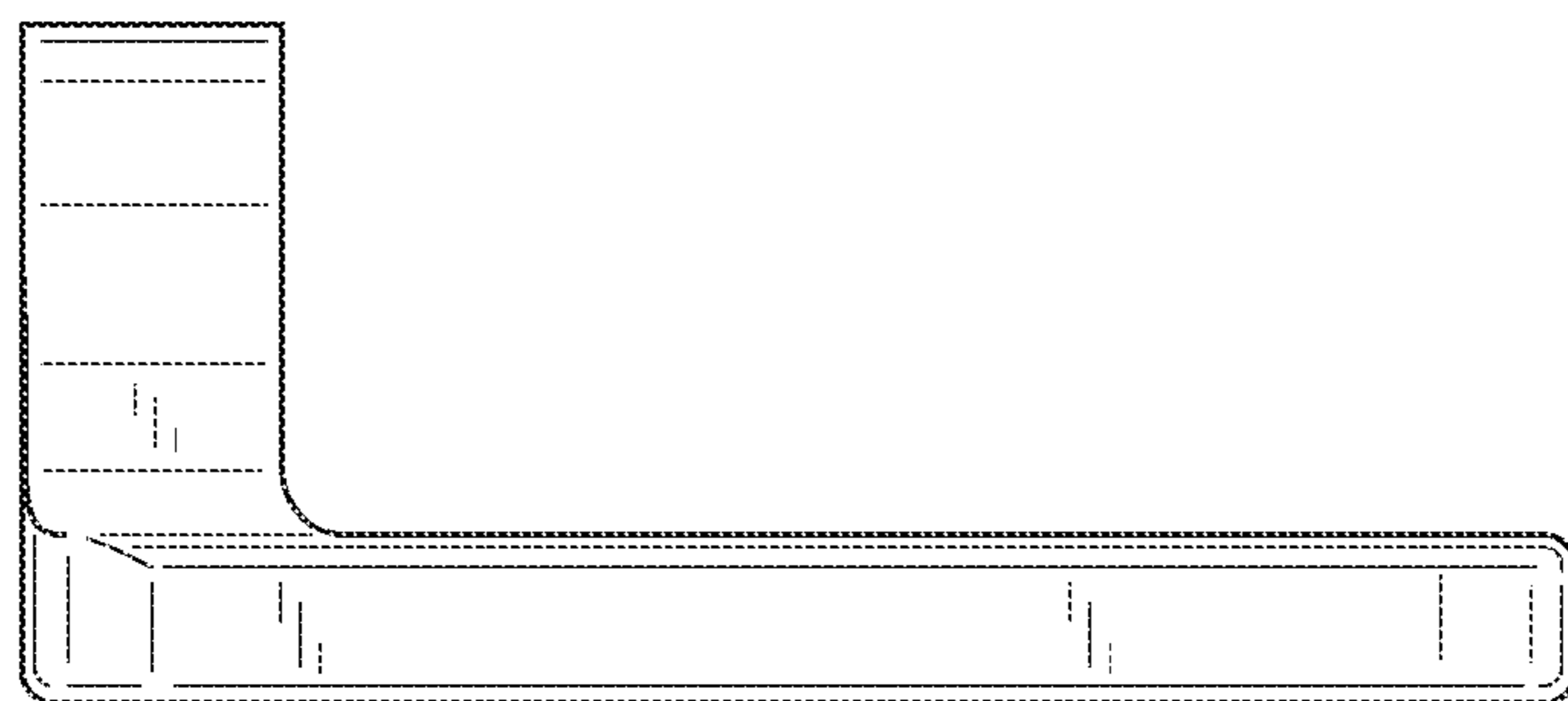

FIG. 4

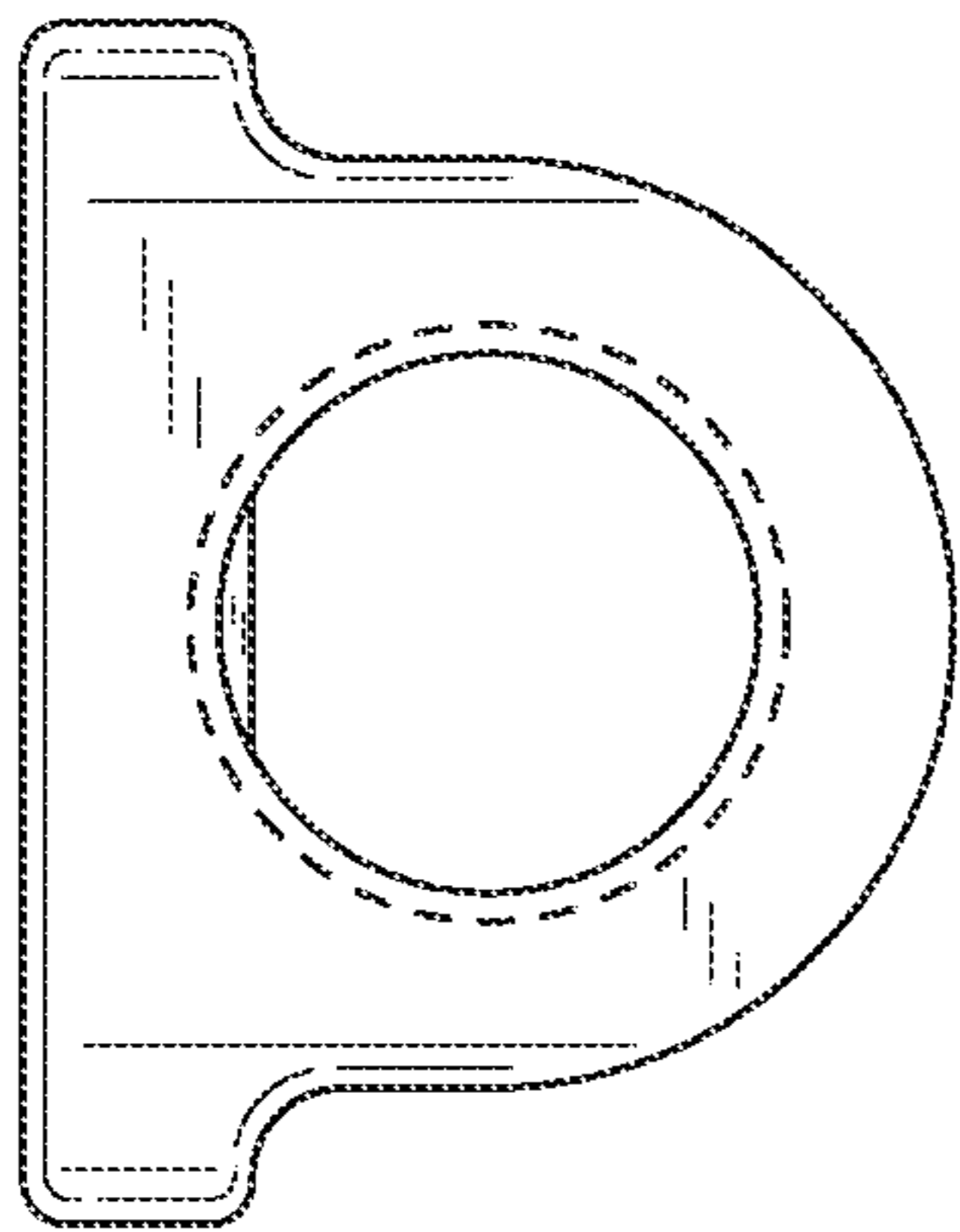

FIG.5

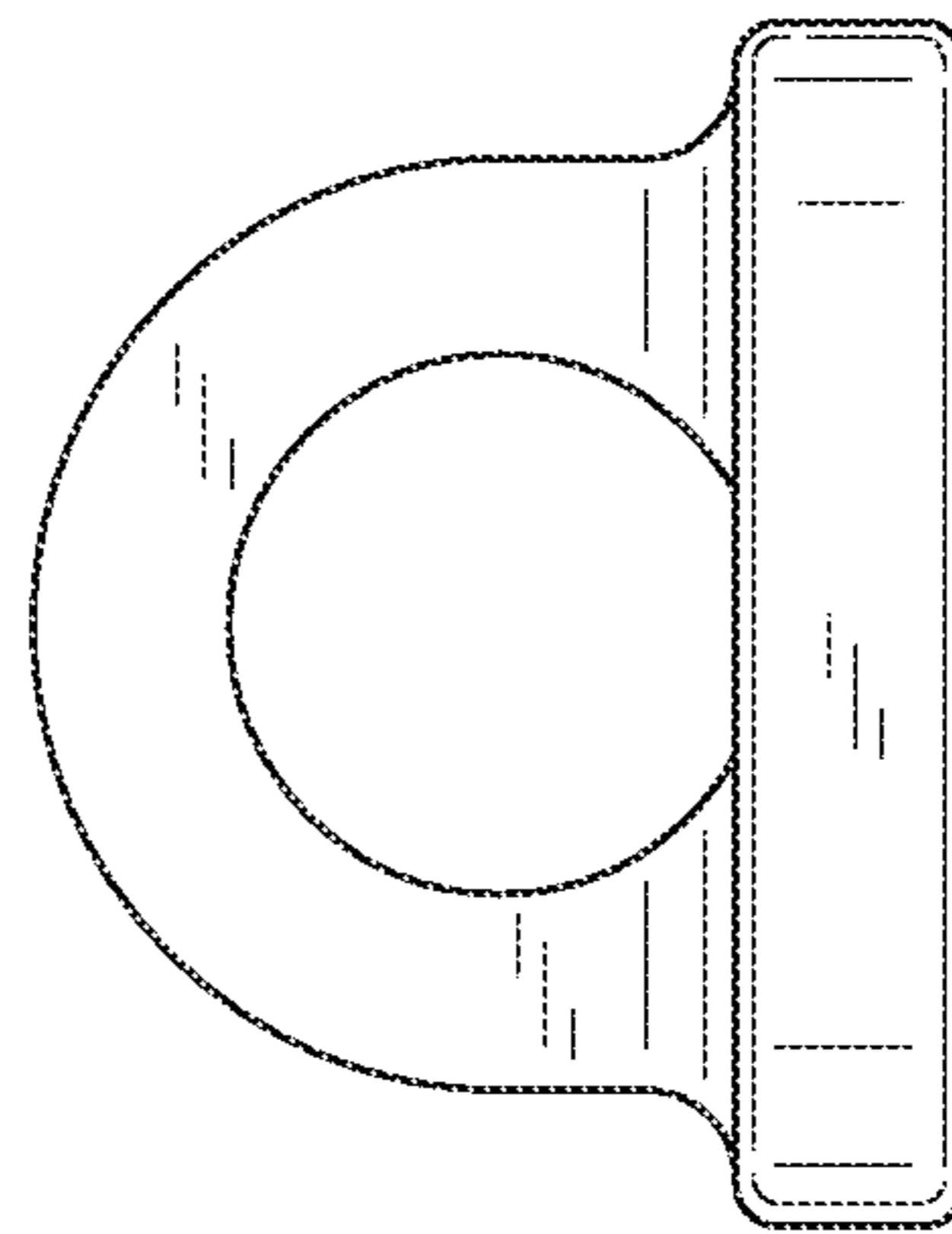

FIG.6