



US00D685304S

(12) **United States Design Patent**
Moore

(10) **Patent No.:** **US D685,304 S**
(45) **Date of Patent:** **** Jul. 2, 2013**

- (54) **BRAKE PAD**
- (71) Applicant: **Wayne-Ian Moore**, Changhua County (TW)
- (72) Inventor: **Wayne-Ian Moore**, Changhua County (TW)
- (73) Assignee: **Ashima Ltd.**, Changhua County (TW)
- (**) Term: **14 Years**
- (21) Appl. No.: **29/443,698**
- (22) Filed: **Jan. 22, 2013**
- (51) **LOC (9) Cl.** **12-16**
- (52) **U.S. Cl.**
USPC **D12/180**
- (58) **Field of Classification Search**
USPC D12/179, 180; 188/71.1, 71.5, 73.1, 188/73.31-73.39, 107 R, 107 M, 264 A, 188/264 AA, 18 A, 218 XL, 108, 149; 192/217
See application file for complete search history.

4,993,520	A *	2/1991	Goddard et al.	188/73.38
5,238,090	A *	8/1993	Weiler	188/71.6
6,427,810	B2 *	8/2002	Schorn et al.	188/73.39
6,651,785	B2 *	11/2003	Cornolti et al.	188/73.1
7,631,733	B2 *	12/2009	Roberts et al.	188/73.1
8,016,084	B2 *	9/2011	Camilo-Martinez et al.	188/73.38
D669,828	S *	10/2012	Liu et al.	D12/180
2002/0096403	A1 *	7/2002	Hayford	188/73.31
2009/0071766	A1 *	3/2009	Gaulrapp et al.	188/72.1

* cited by examiner

Primary Examiner — Susan M Lee
Assistant Examiner — Linda G Brooks

(57) **CLAIM**
The ornamental design for a brake pad, as shown and described.

DESCRIPTION

FIG. 1 is a perspective view of a brake pad showing my new design;
FIG. 2 is a front elevational view thereof;
FIG. 3 is a rear elevational view thereof;
FIG. 4 is a left side view thereof;
FIG. 5 is a right side view thereof;
FIG. 6 is a top plan view thereof; and,
FIG. 7 is a bottom plan view thereof.

1 Claim, 4 Drawing Sheets

- (56) **References Cited**
U.S. PATENT DOCUMENTS
D260,014 S * 7/1981 Sheill D12/180
D260,015 S * 7/1981 Sheill D12/180
4,991,697 A * 2/1991 Hummel et al. 188/250 B

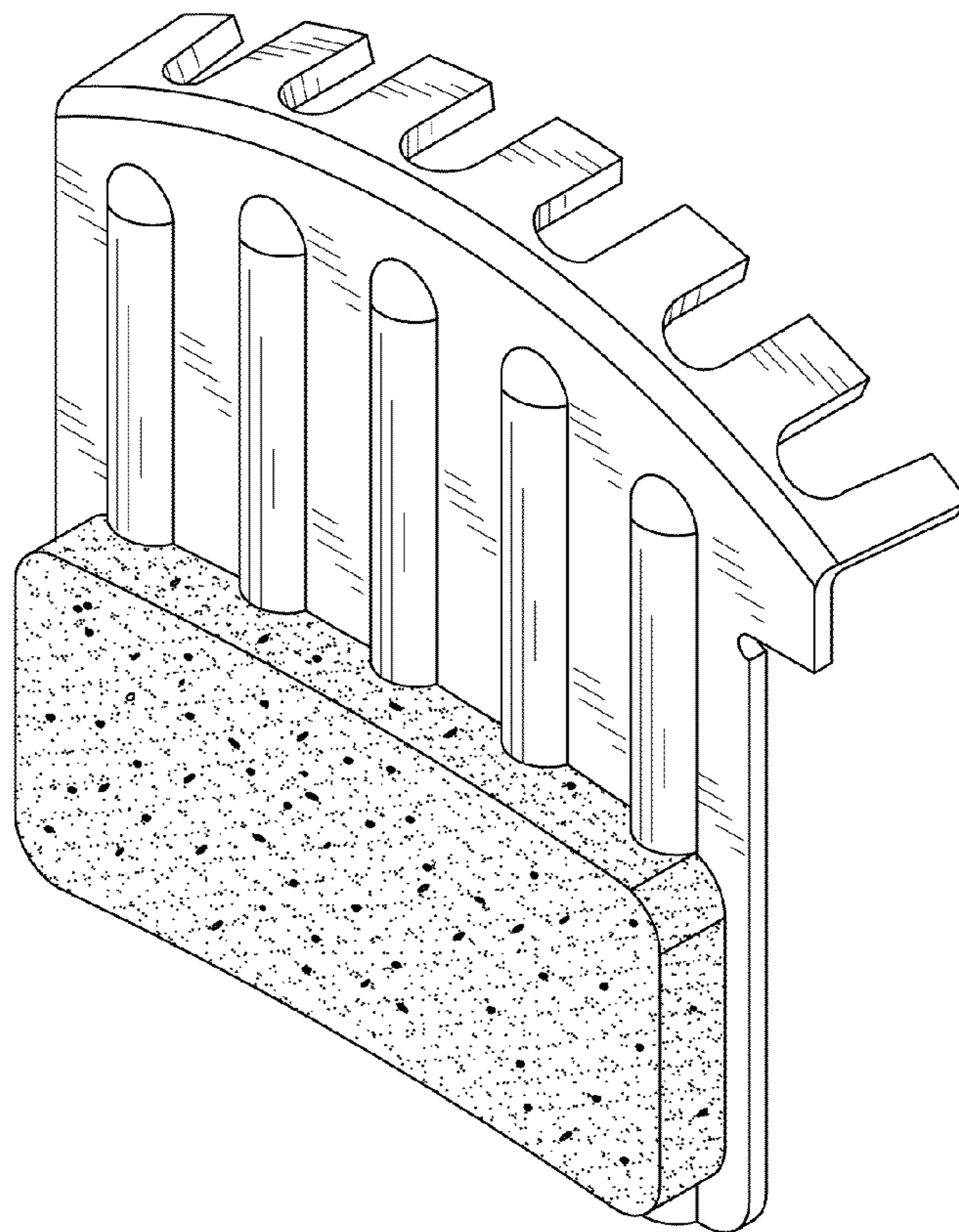

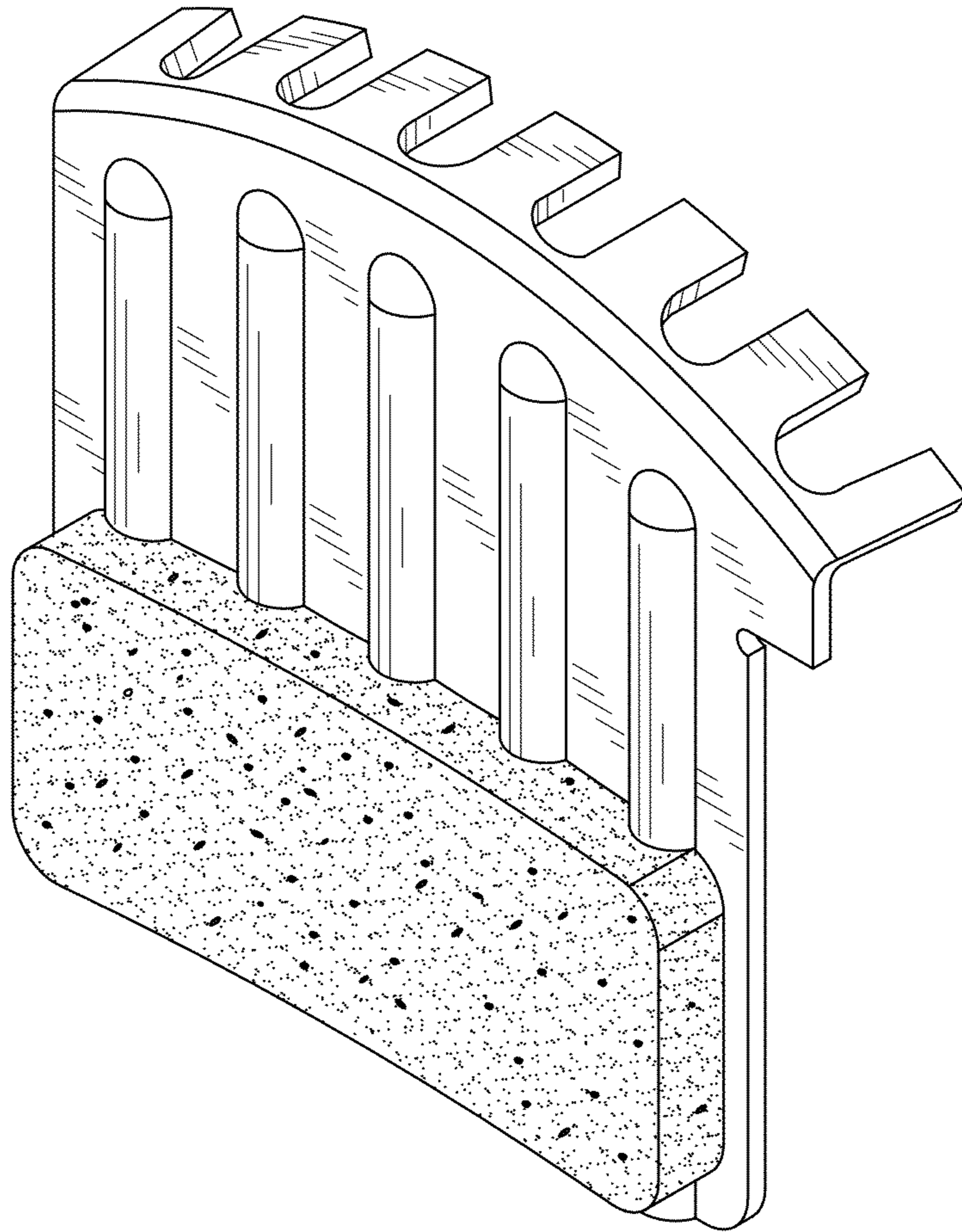

FIG. 1

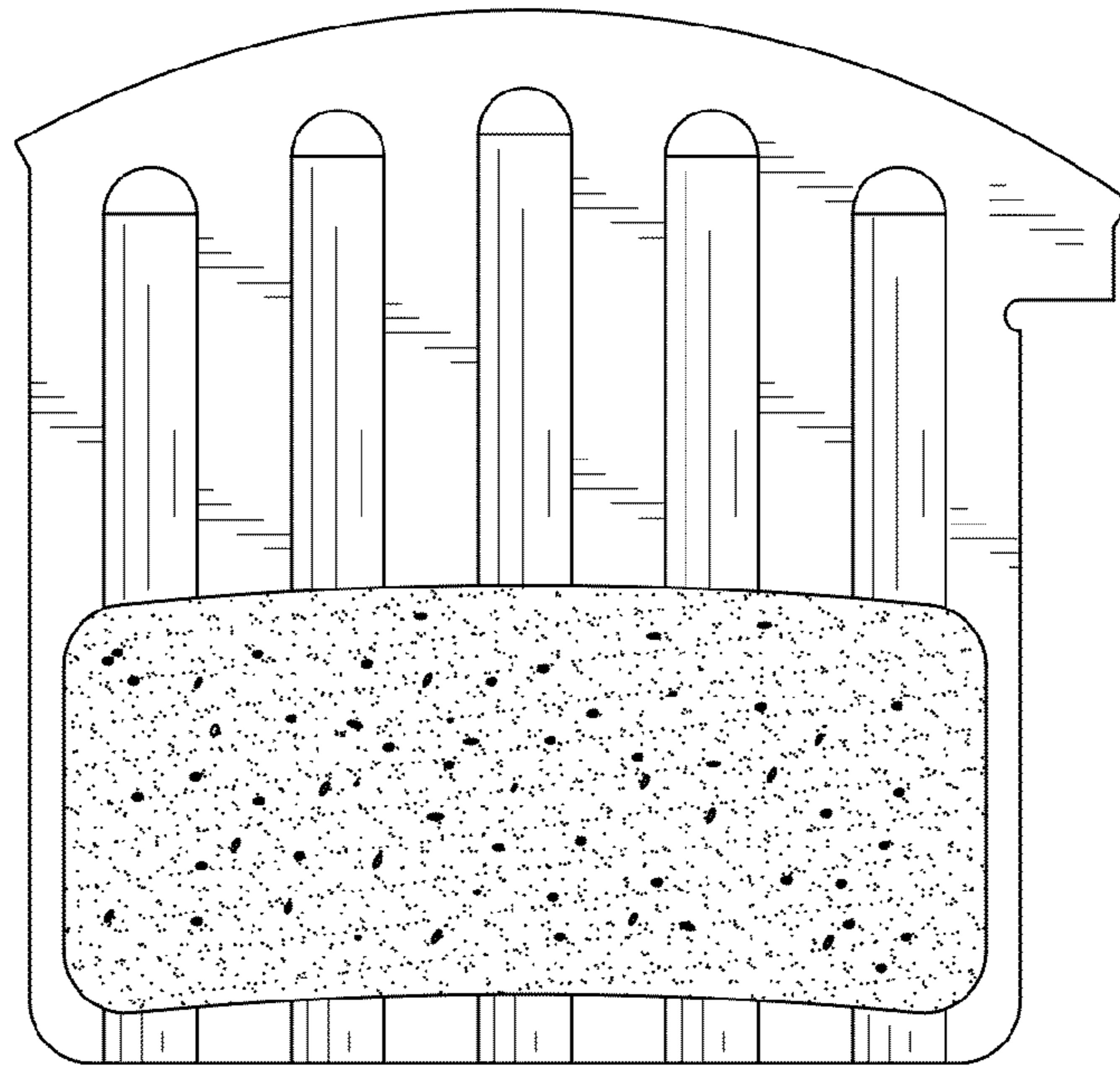

FIG. 2

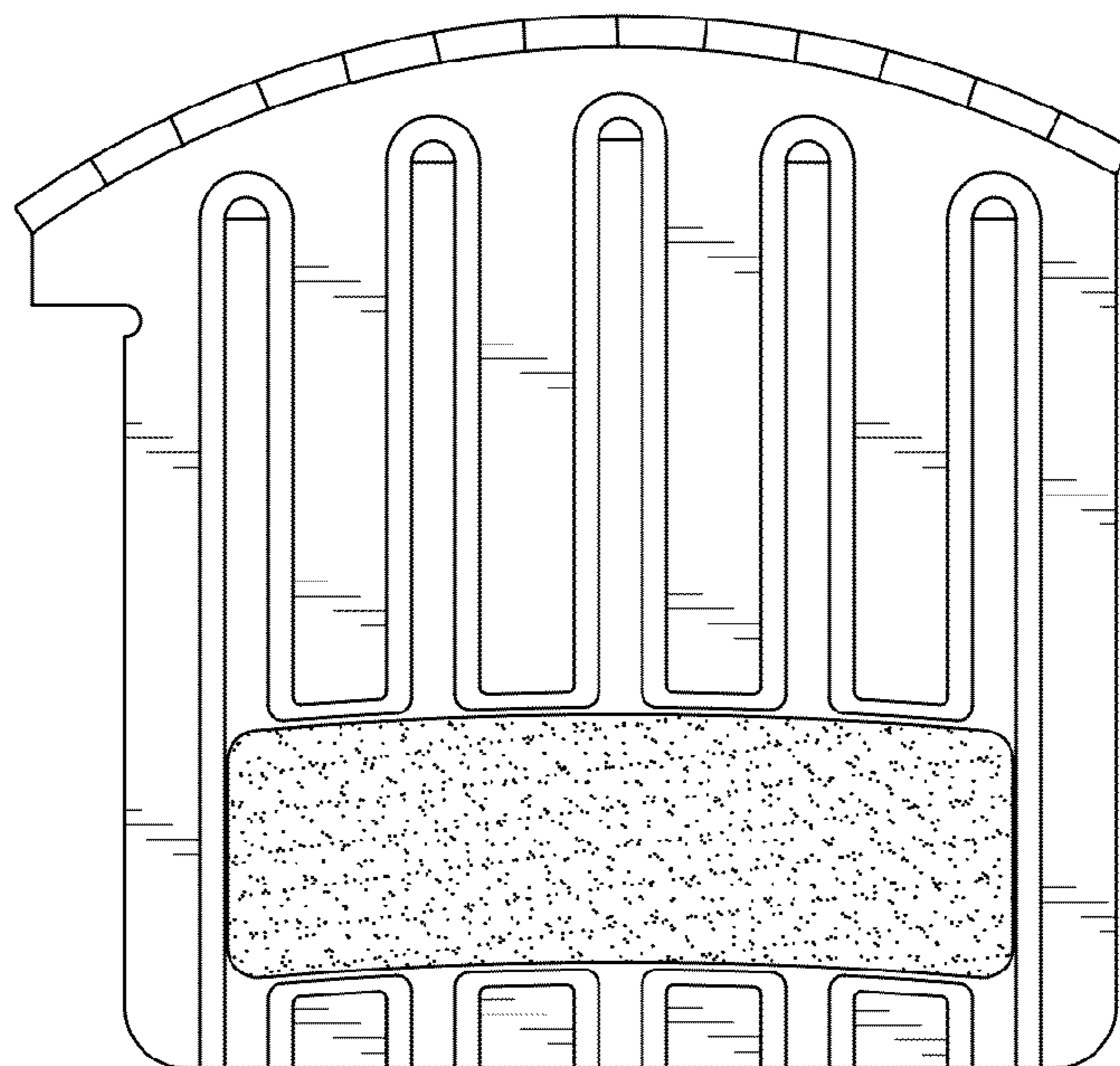

FIG. 3

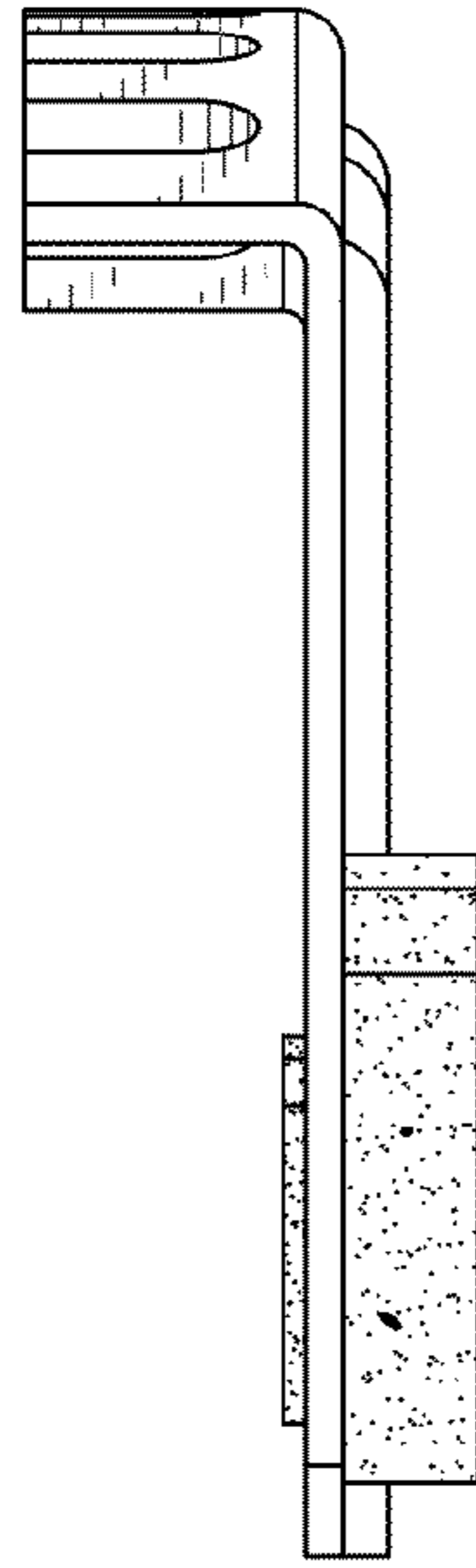

FIG. 4

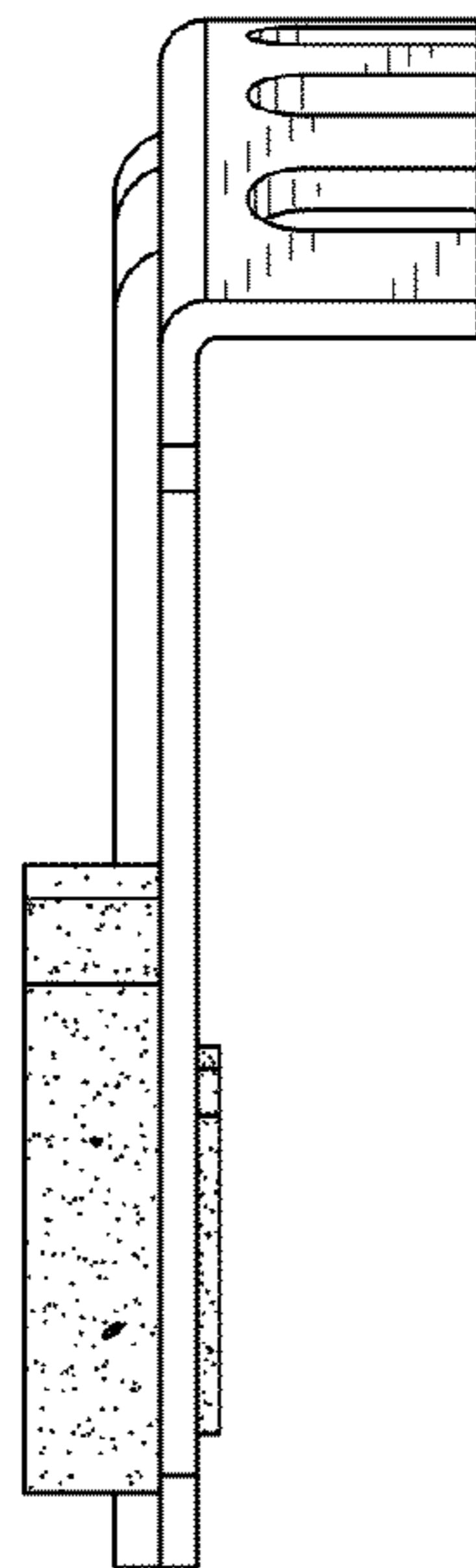

FIG. 5

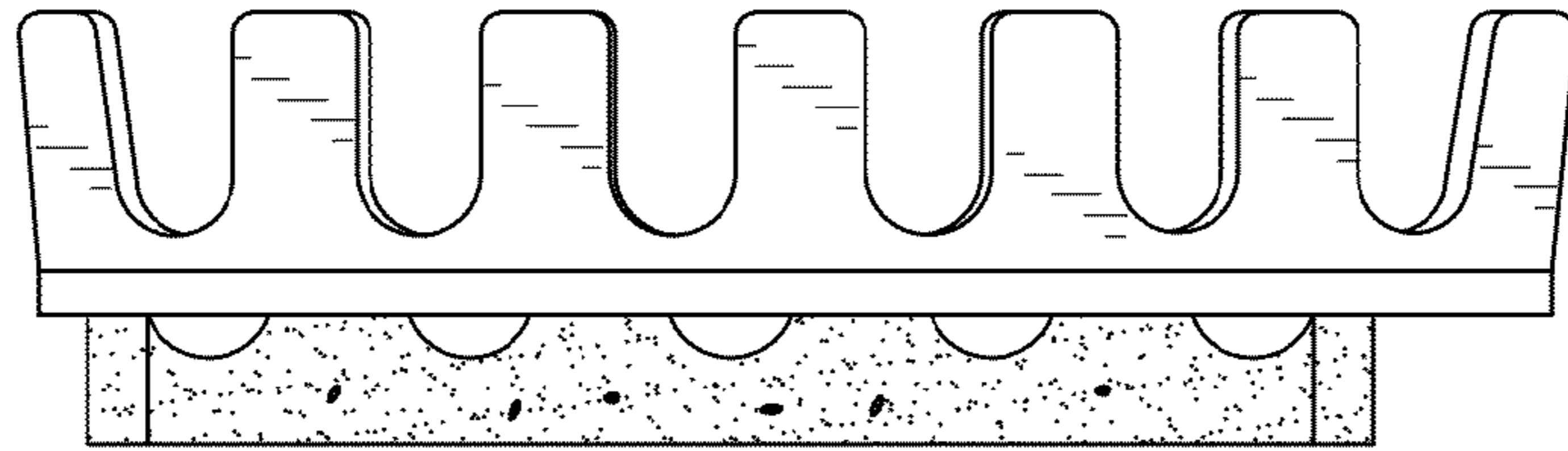

FIG. 6

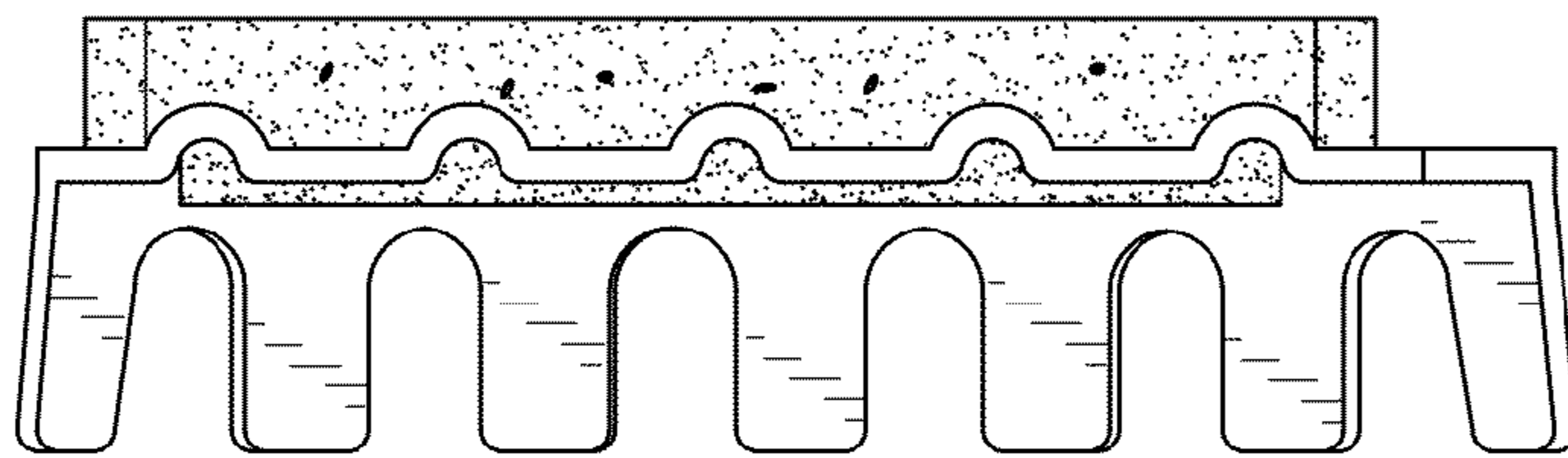

FIG. 7