



US00D685295S

(12) **United States Design Patent**  
**Mori et al.**

(10) **Patent No.:** **US D685,295 S**  
(45) **Date of Patent:** **\*\* Jul. 2, 2013**

(54) **AUTO-UNICYCLE WITH A SAFETY WHEEL**

(75) Inventors: **Yasuka Mori**, Wako (JP); **Yuichi Yokoyama**, Wako (JP); **Masamoto Ito**, Wako (JP)

(73) Assignee: **Honda Motor Co., Ltd.**, Tokyo (JP)

(\*\*) Term: **14 Years**

(21) Appl. No.: **29/431,971**

(22) Filed: **Sep. 12, 2012**

(30) **Foreign Application Priority Data**

Mar. 19, 2012 (JP) ..... 2012-006185

(51) **LOC (9) Cl.** ..... **12-11**

(52) **U.S. Cl.**  
USPC ..... **D12/107**

(58) **Field of Classification Search**  
USPC ..... D12/107, 1, 110; 280/200, 400, 401, 280/491.1, 492, 205, 638, 639, 226.1, 287, 280/47.16, 47.32, 78, 288, 275, 278, 276, 280/293, 47.2, 7.15, 7.17, 29, 30, 43.23; 180/20, 180/21, 65.51, 65.1, 205, 208, 7.1, 11-13, 180/313

See application file for complete search history.

(56) **References Cited**

**U.S. PATENT DOCUMENTS**

4,861,053 A \* 8/1989 Yeomans, Jr. .... 280/205  
5,314,034 A \* 5/1994 Chittal ..... 180/21  
5,868,413 A \* 2/1999 Cabrera ..... 280/205  
D505,363 S \* 5/2005 Aube et al. .... D12/107  
D560,560 S \* 1/2008 Dacsev ..... D12/107

7,762,569 B2 \* 7/2010 Fraser ..... 280/205  
D626,892 S \* 11/2010 Shin ..... D12/107  
D673,081 S \* 12/2012 Chen ..... D12/107  
2008/0143073 A1 \* 6/2008 Ungar et al. .... 280/205

\* cited by examiner

*Primary Examiner* — Susan M Lee

*Assistant Examiner* — Linda G Brooks

(74) *Attorney, Agent, or Firm* — Birch, Stewart, Kolasch & Birch, LLP

(57) **CLAIM**

The ornamental design for an auto-unicycle with a safety wheel, as shown and described.

**DESCRIPTION**

FIG. 1 is a perspective view from the front side of an auto-unicycle with a safety wheel.

FIG. 2 is a perspective view from the rear side thereof.

FIG. 3 is a perspective view from the front side thereof.

FIG. 4 is a perspective view from the rear side thereof.

FIG. 5 is a front elevation view thereof.

FIG. 6 is a rear elevation view thereof.

FIG. 7 is a left side elevation view thereof.

FIG. 8 is a right side elevation view thereof.

FIG. 9 is a top plan view thereof.

FIG. 10 is a bottom plan view thereof.

FIG. 11 is a right side elevation view with the seat raised.

FIG. 12 is a right side elevation view with the safety wheel raised; and,

FIG. 13 is a front elevation view with the pedals tilted.

The portions of the auto-unicycle shown in broken lines are for the purpose of showing environmental structure only and form no part of the claimed design.

**1 Claim, 13 Drawing Sheets**

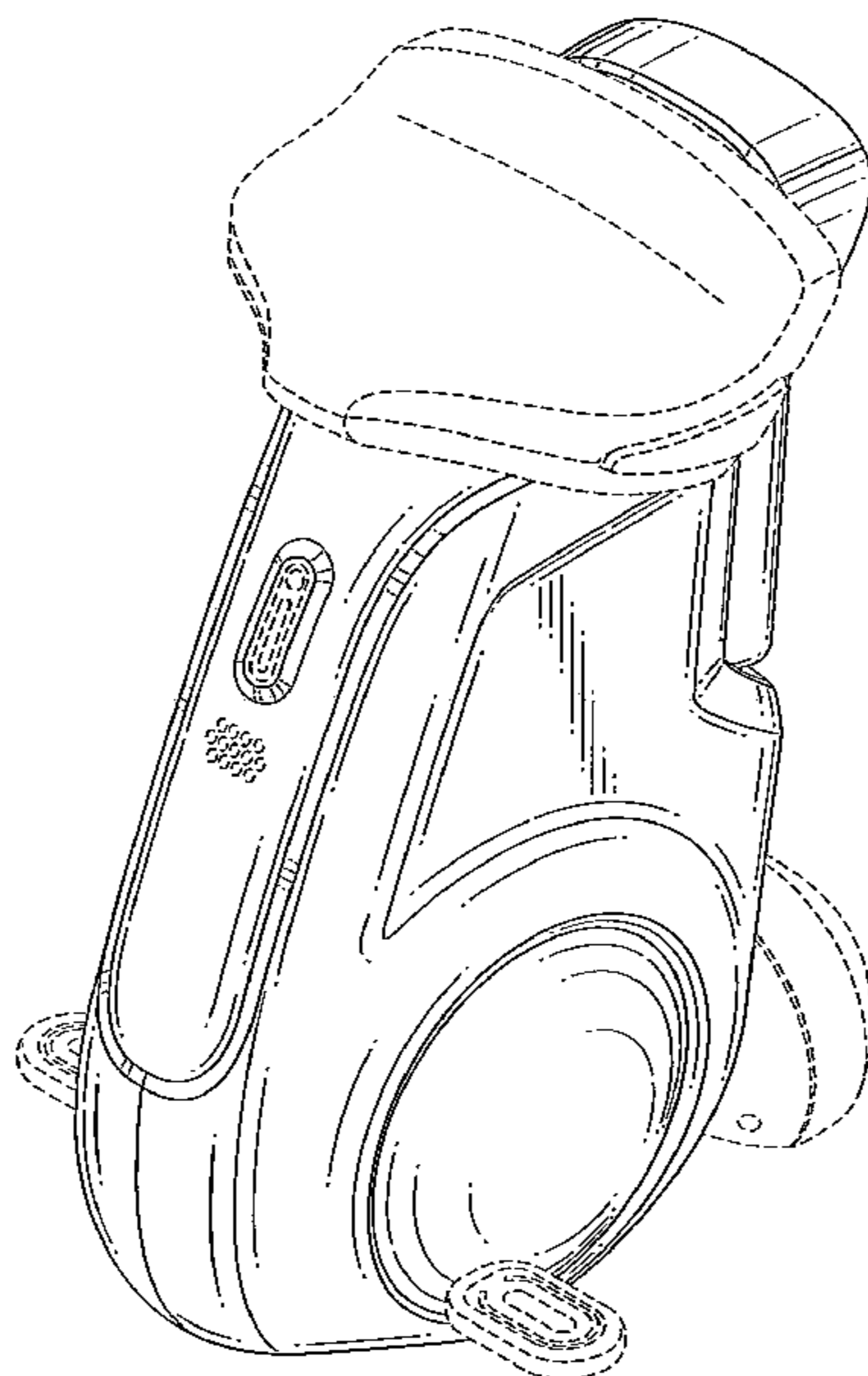

FIG. 1

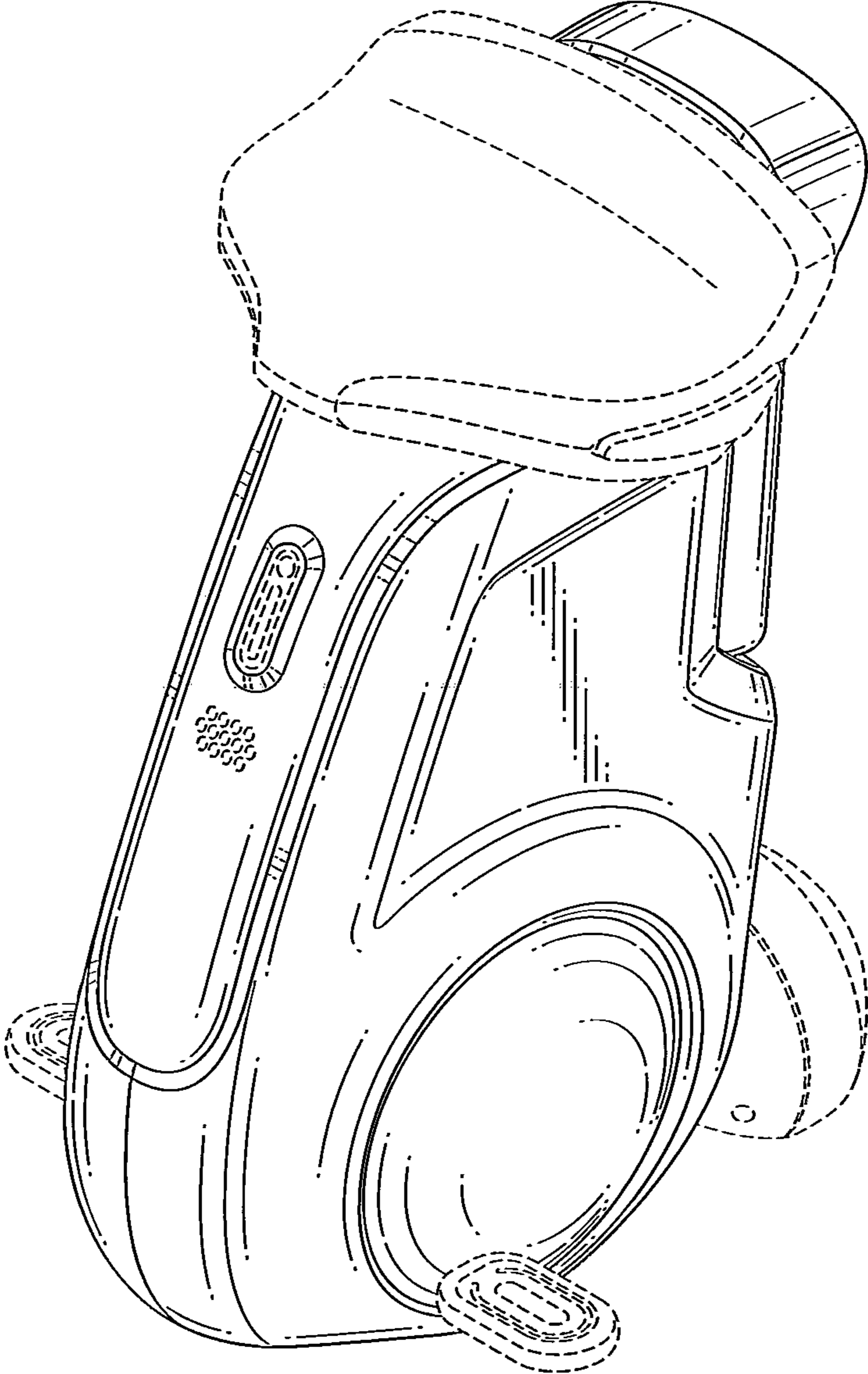

FIG. 2

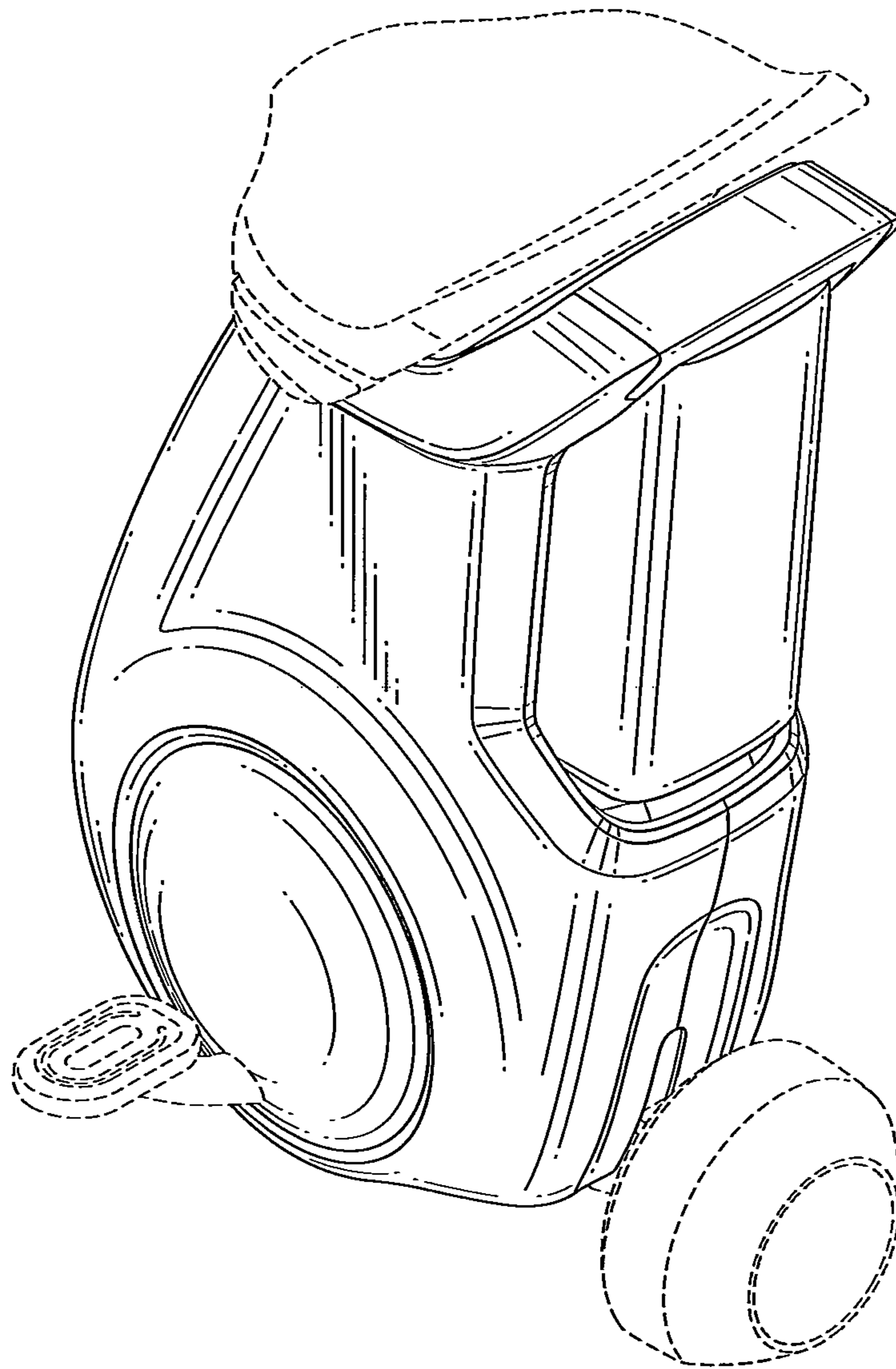

FIG. 3

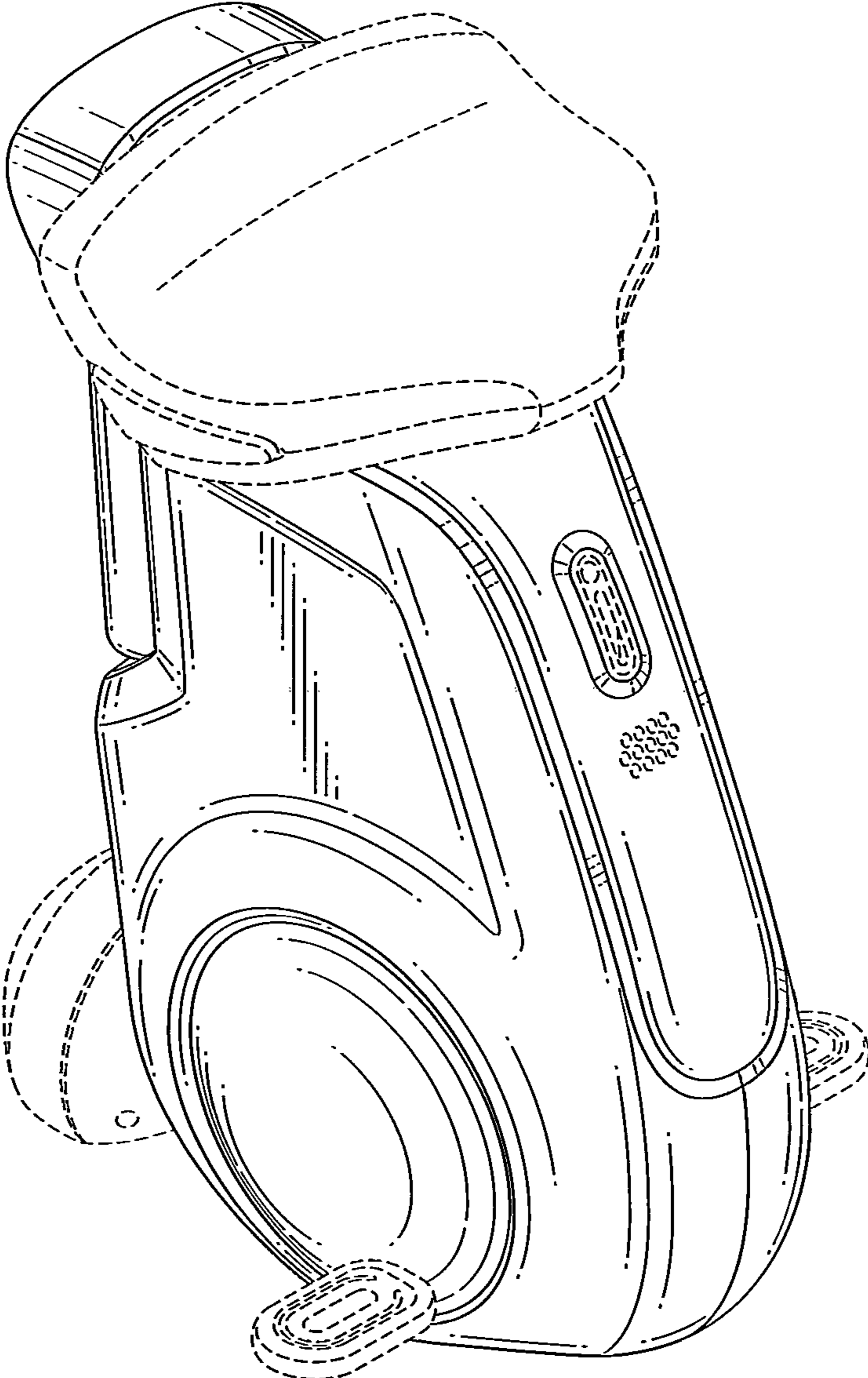



FIG. 4

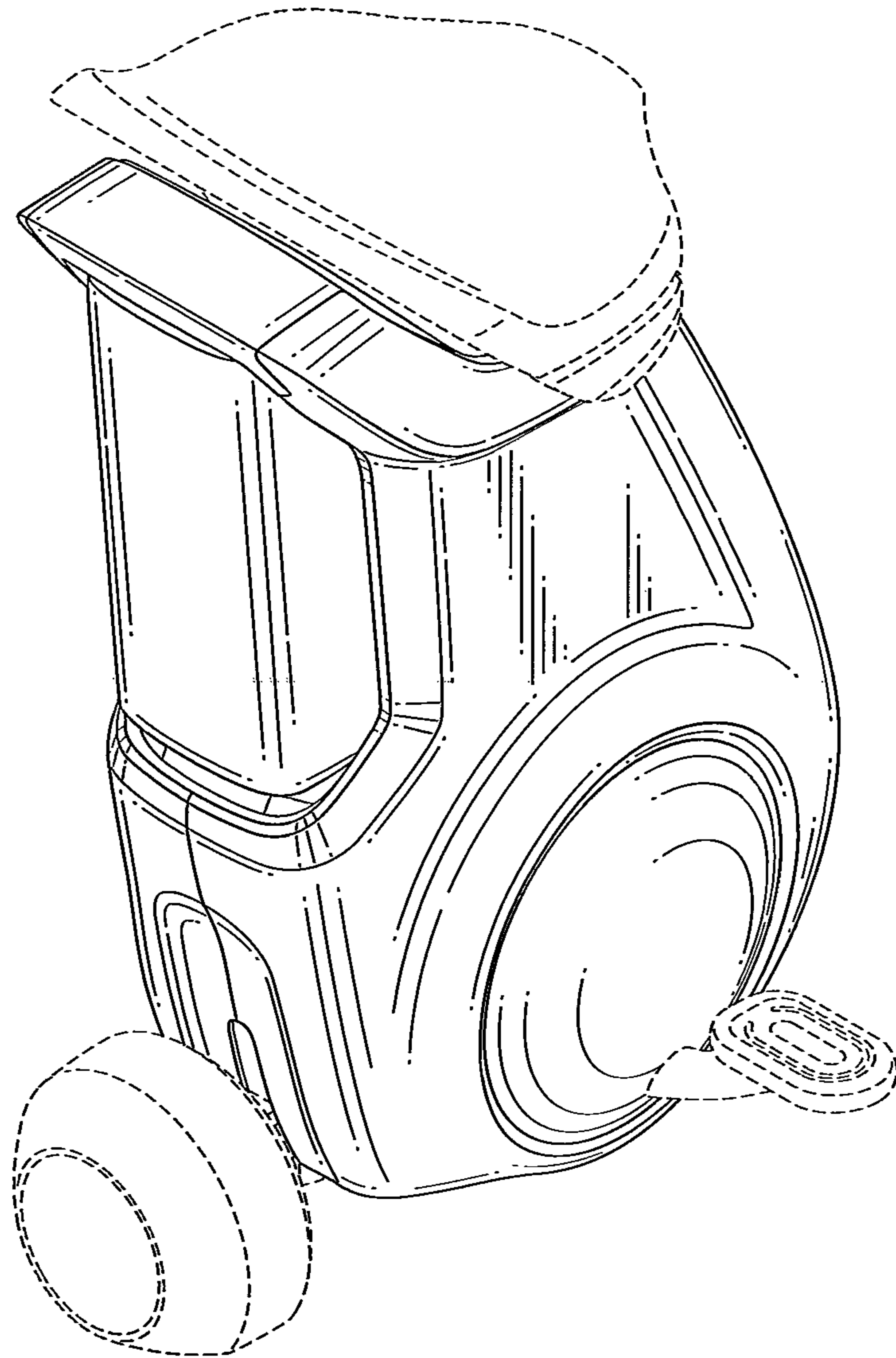

FIG. 5

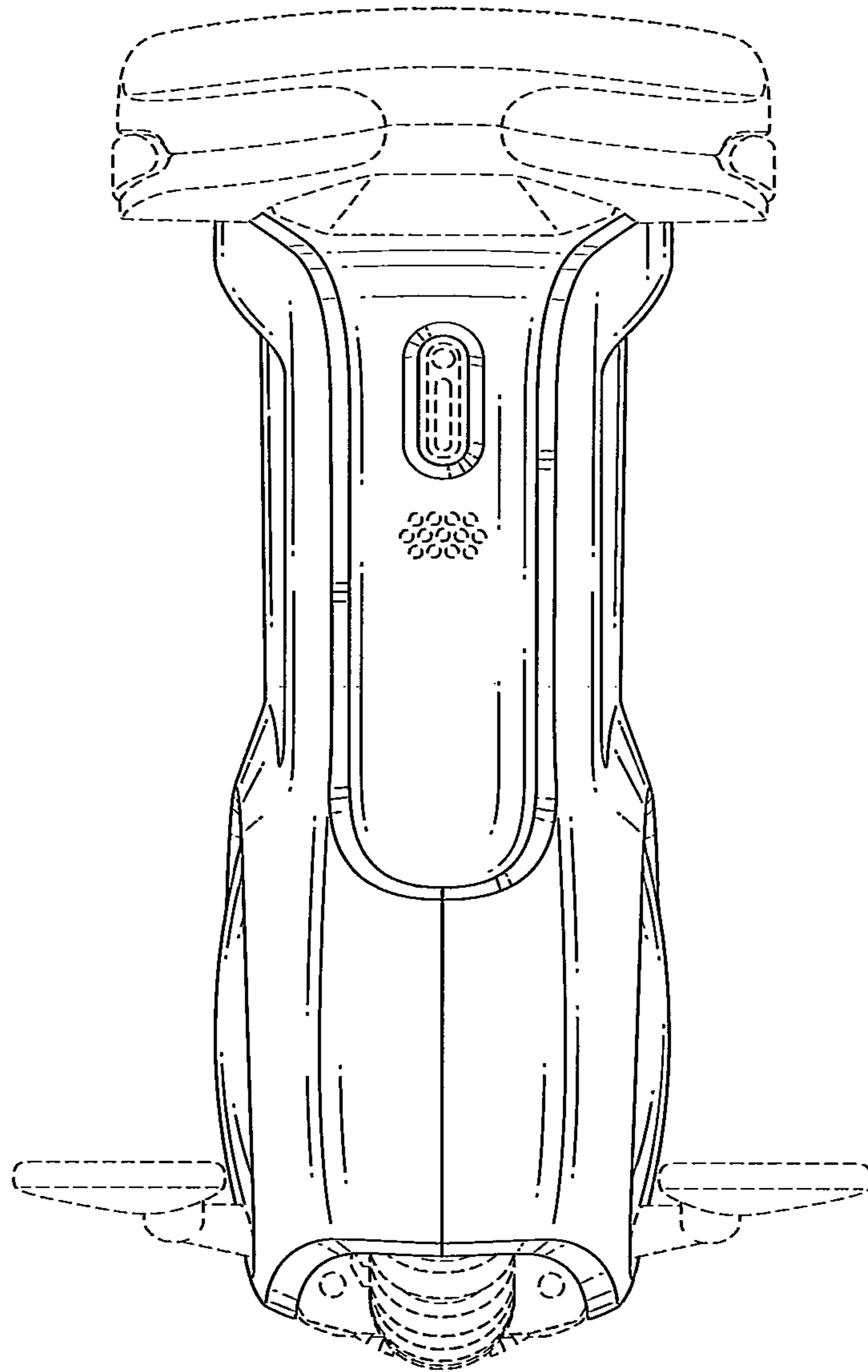

FIG. 6

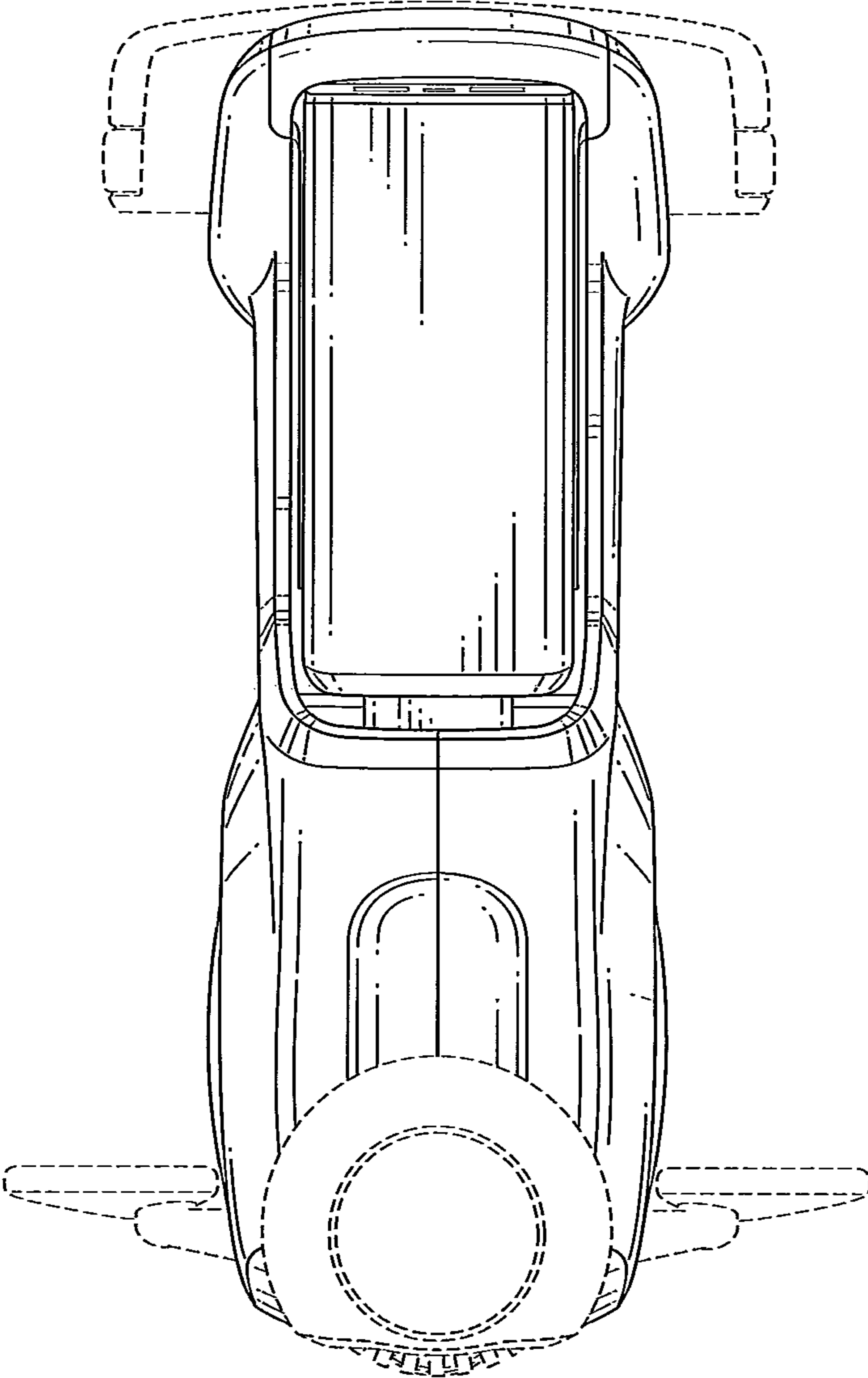

FIG. 7

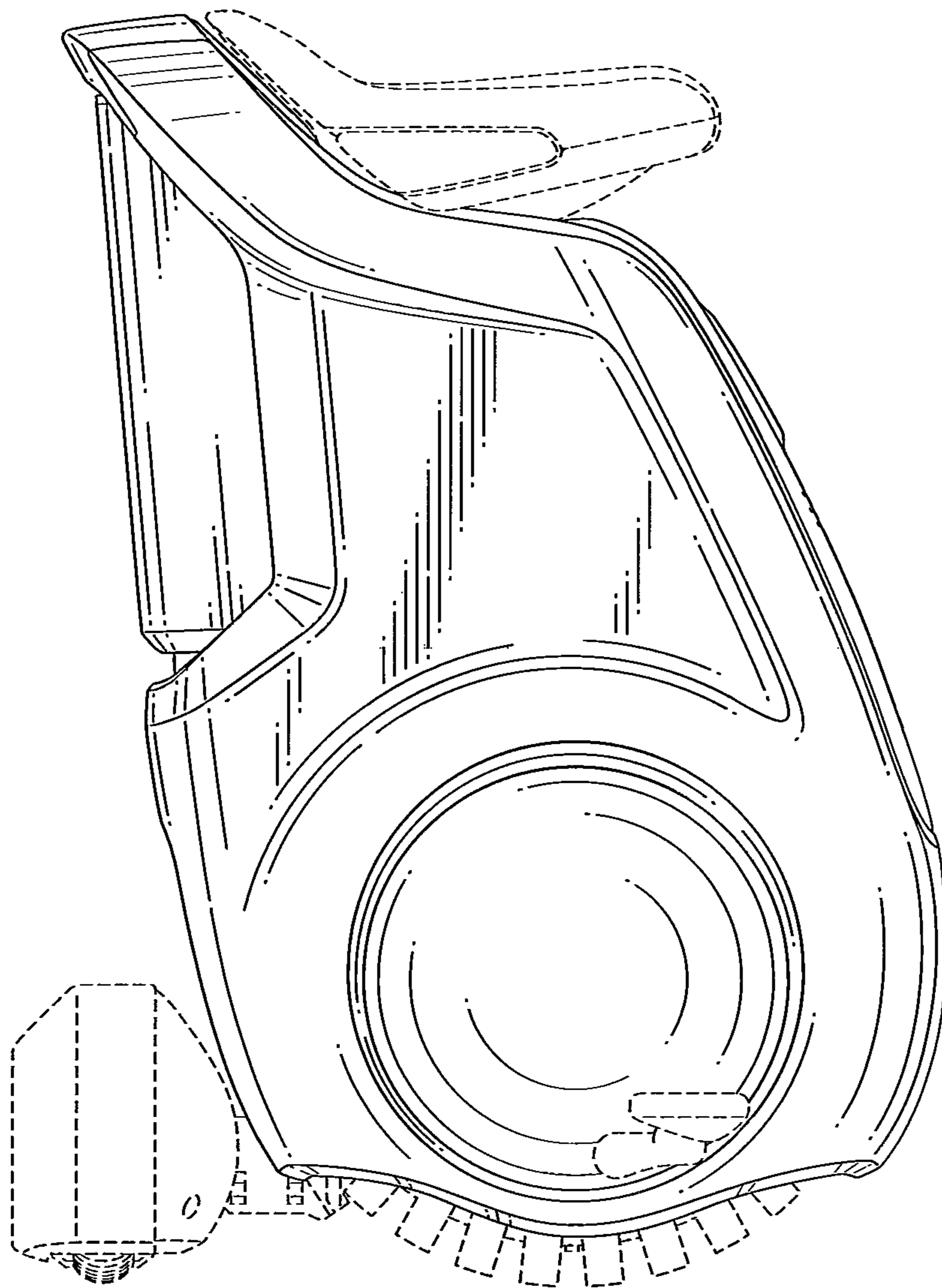



FIG. 8

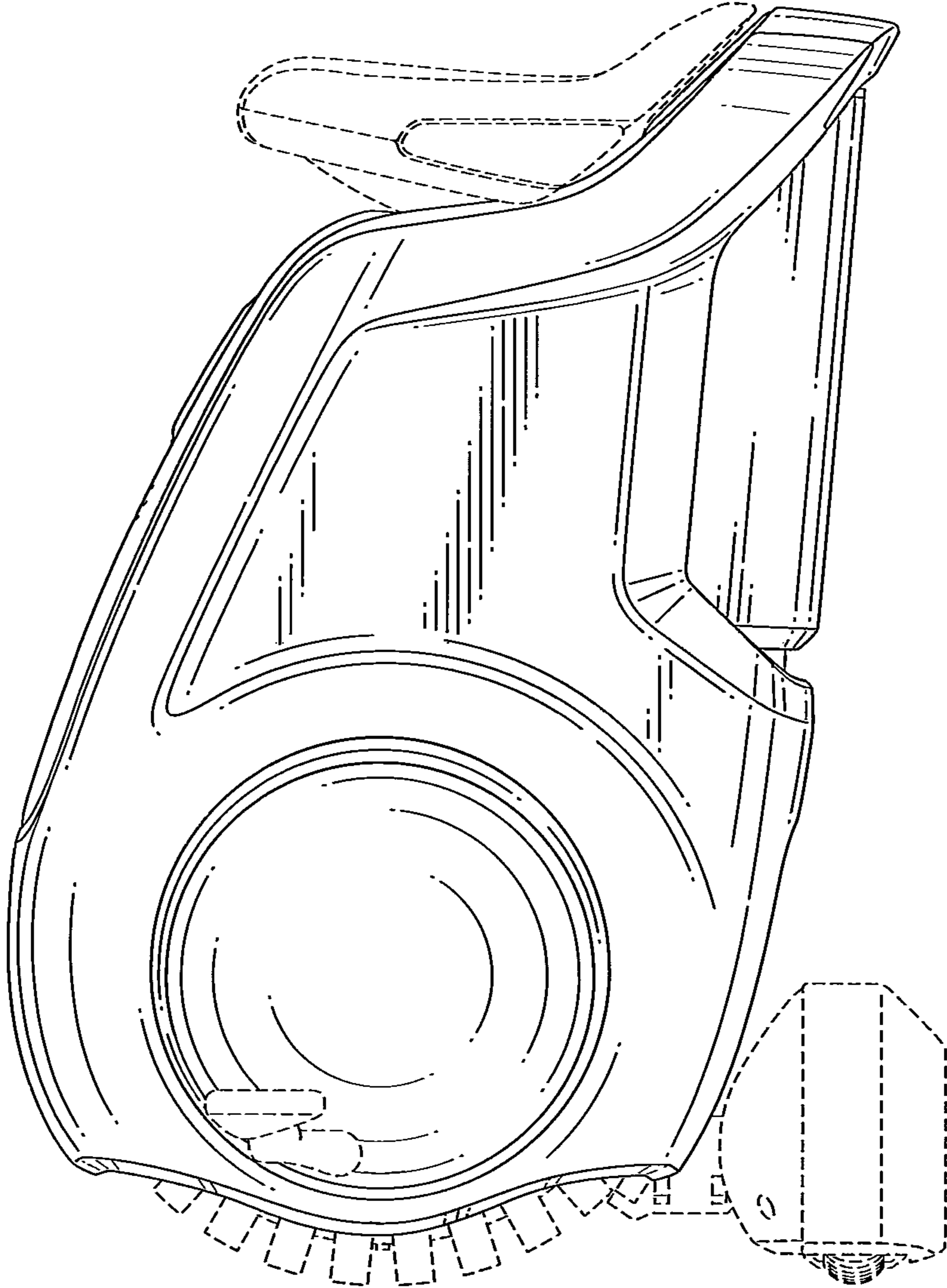

FIG. 9

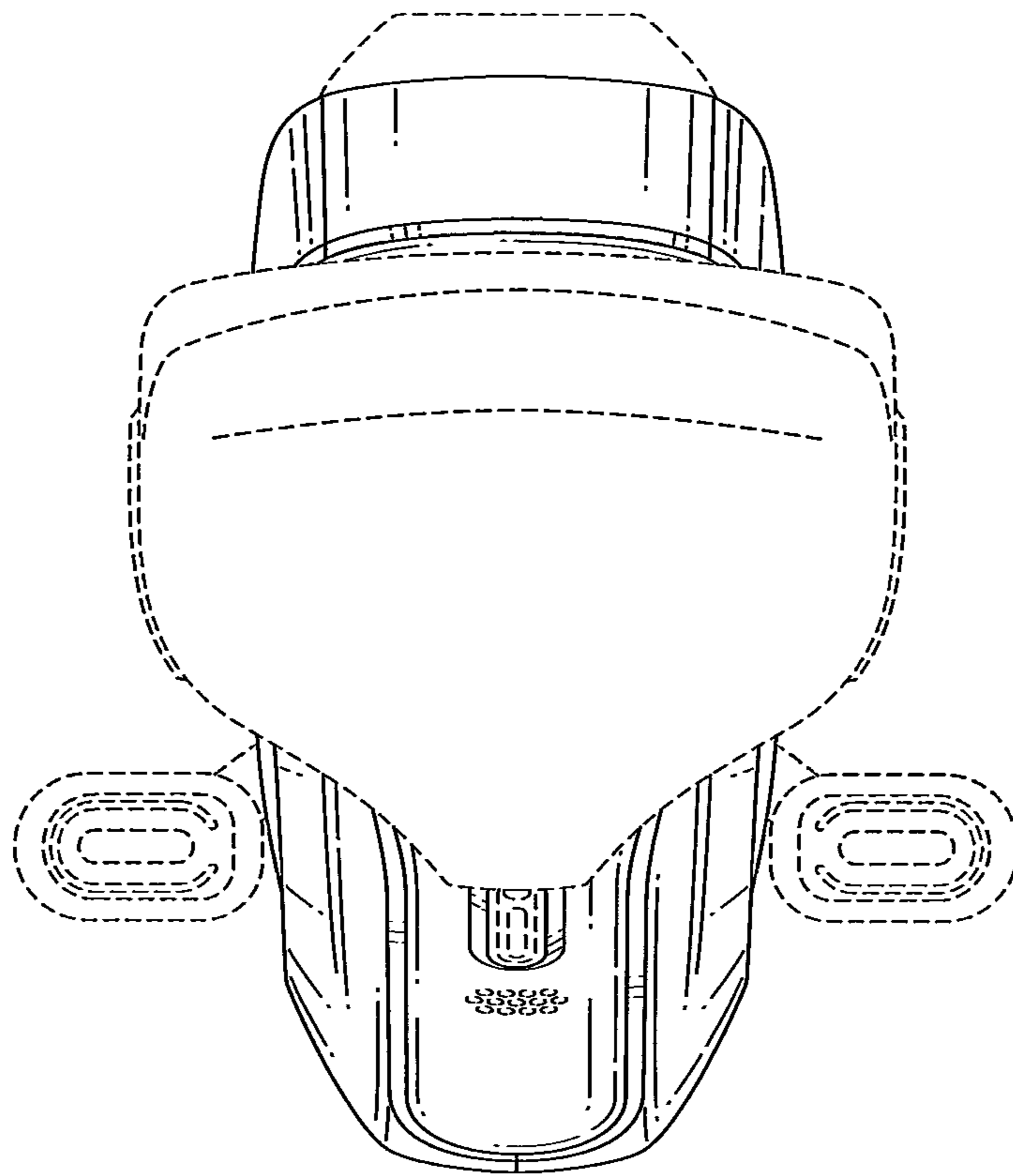

FIG. 10

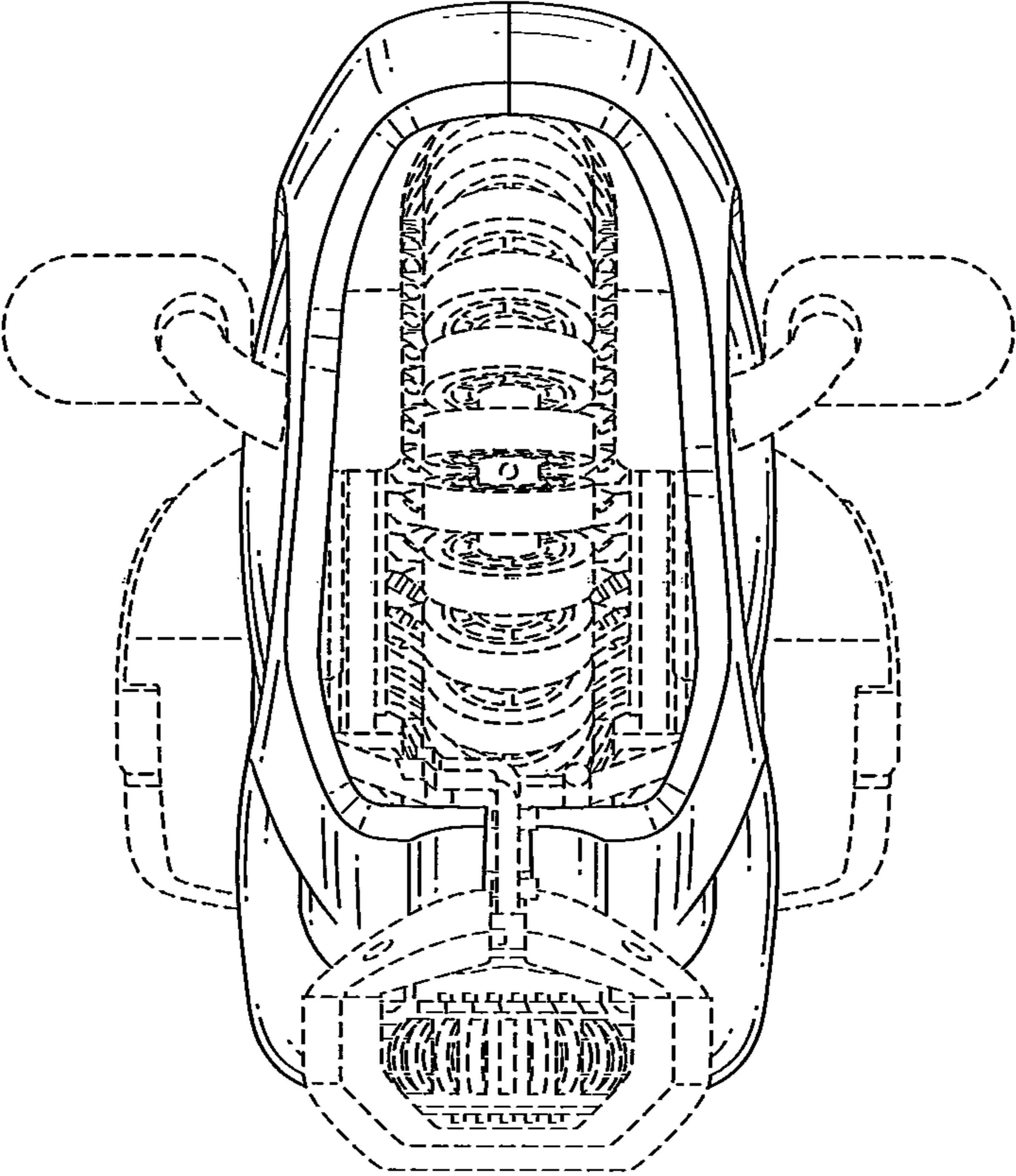

FIG. 11

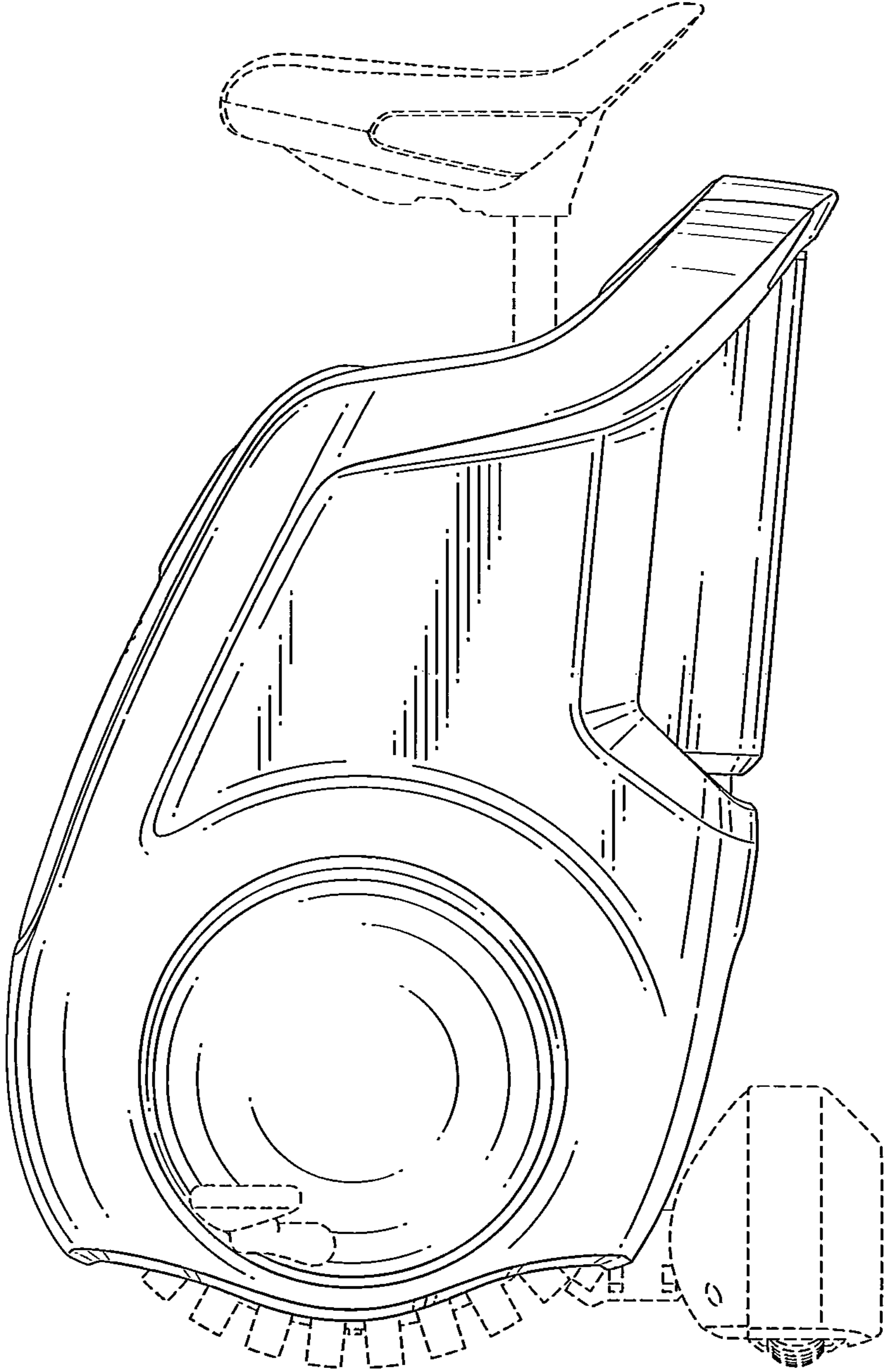

FIG. 12

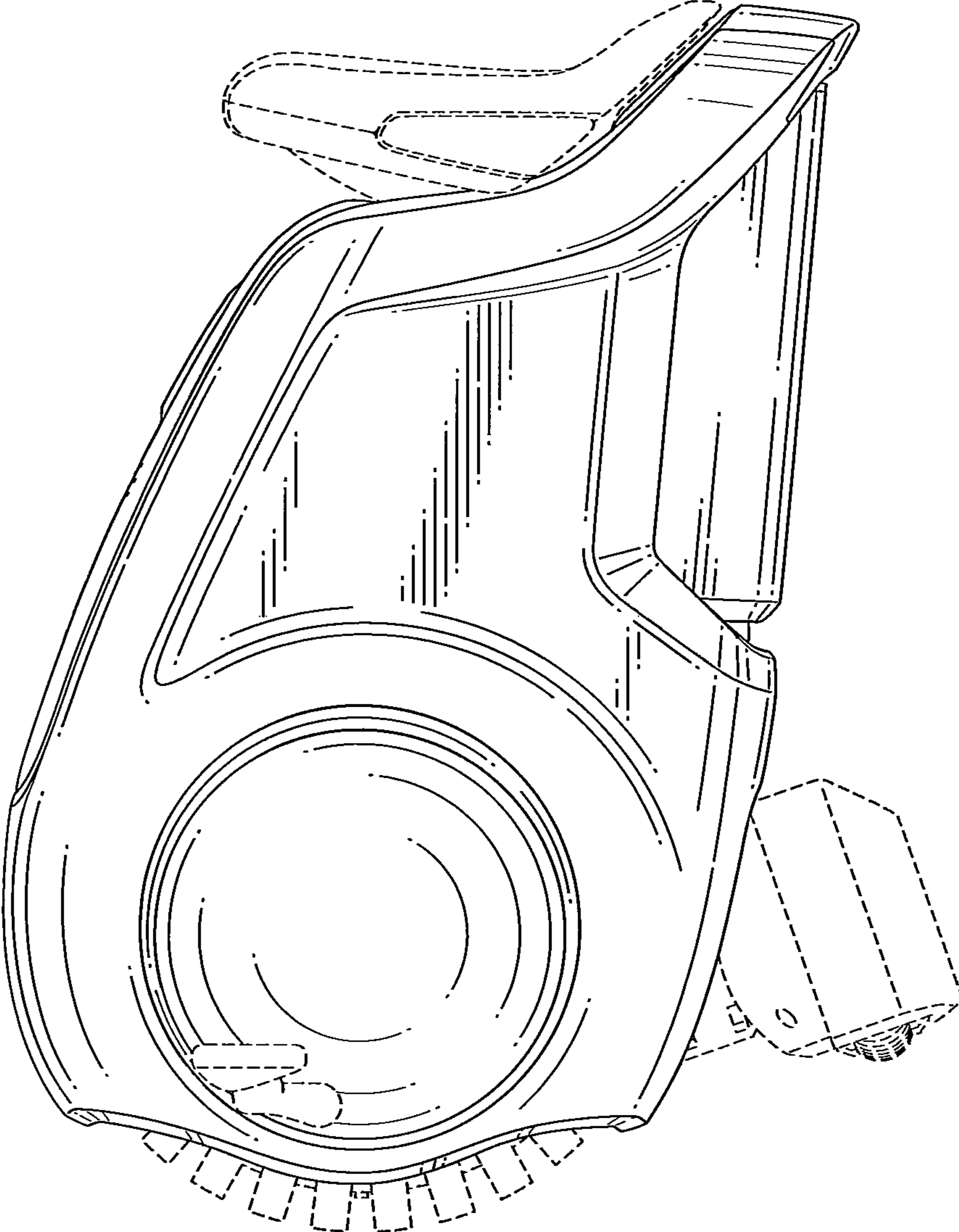



FIG. 13

