



US00D684871S

(12) **United States Design Patent**
Lintner

(10) **Patent No.:** **US D684,871 S**
(45) **Date of Patent:** **** Jun. 25, 2013**

(54) **GROUND PENETRATING RADAR**

(74) *Attorney, Agent, or Firm* — Crowell & Moring LLP

(75) Inventor: **Stephan Lintner**, Salzburg (AT)

(57) **CLAIM**

The ornamental design for a ground penetrating radar, as shown and described.

(73) Assignee: **Hilti Aktiengesellschaft**, Schaan (LI)

(**) Term: **14 Years**

DESCRIPTION

(21) Appl. No.: **29/404,957**

FIG. 1 is a left, top, front perspective view of a first embodiment of a ground penetrating radar according to my design; FIG. 2 is a right, bottom, rear perspective view thereof; FIG. 3 is a right side view thereof; FIG. 4 is a left side view thereof; FIG. 5 is a top view thereof; FIG. 6 is a bottom view thereof; FIG. 7 is a front view thereof; and FIG. 8 is a rear view thereof.

(22) Filed: **Oct. 27, 2011**

(30) **Foreign Application Priority Data**

Jun. 24, 2011 (WO) DM/076 318

(51) **LOC (9) Cl.** **10-04**

(52) **U.S. Cl.**
USPC **D10/47**

(58) **Field of Classification Search**
USPC D10/47; 324/67, 326, 329; 343/728, 343/788, 867
See application file for complete search history.

FIG. 9 is a left, top, front perspective view of a second embodiment of the ground penetrating radar according to my design; FIG. 10 is a right, bottom, rear perspective view thereof; FIG. 11 is a right side view thereof; FIG. 12 is a left side view thereof; FIG. 13 is a top view thereof; FIG. 14 is a bottom view thereof; FIG. 15 is a front view thereof; and, FIG. 16 is a rear view thereof.

The broken lines are for illustrative purposes only and form no part of the claimed design.

(56) **References Cited**

U.S. PATENT DOCUMENTS

D291,916 S * 9/1987 Davis D10/47
D311,871 S * 11/1990 Duftschmid D10/47

* cited by examiner

Primary Examiner — Antoine D Davis

1 Claim, 16 Drawing Sheets

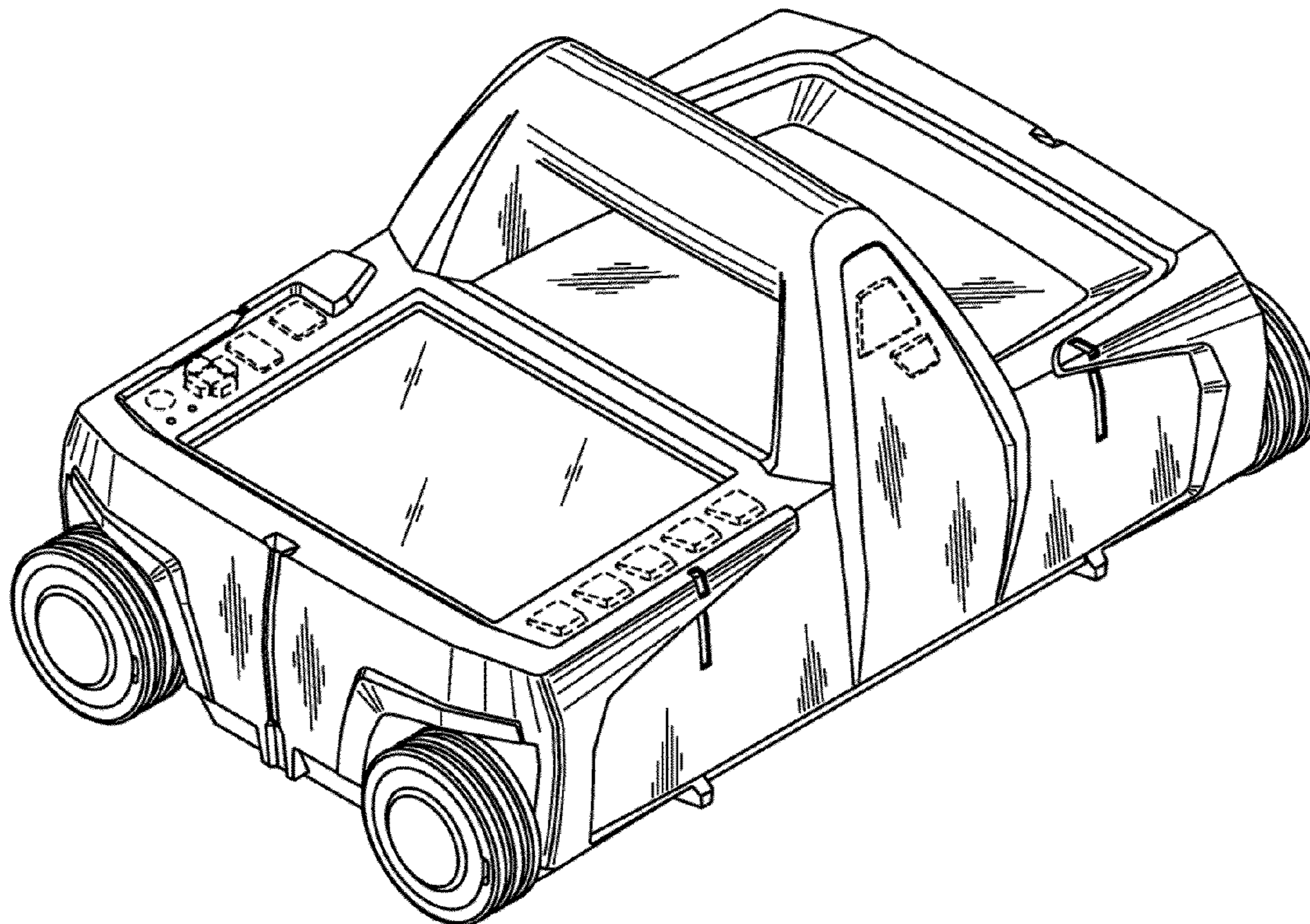

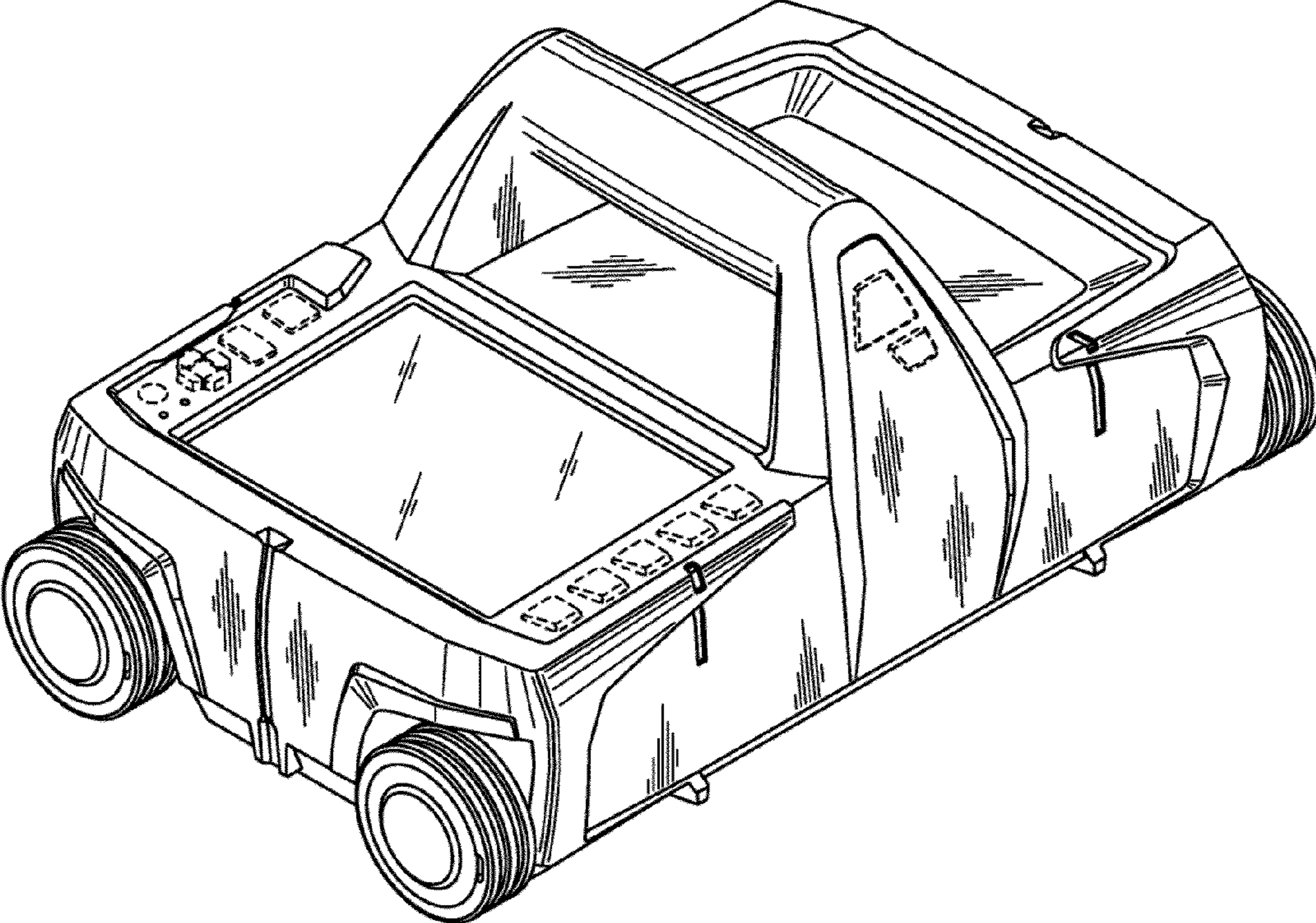

FIG. 1

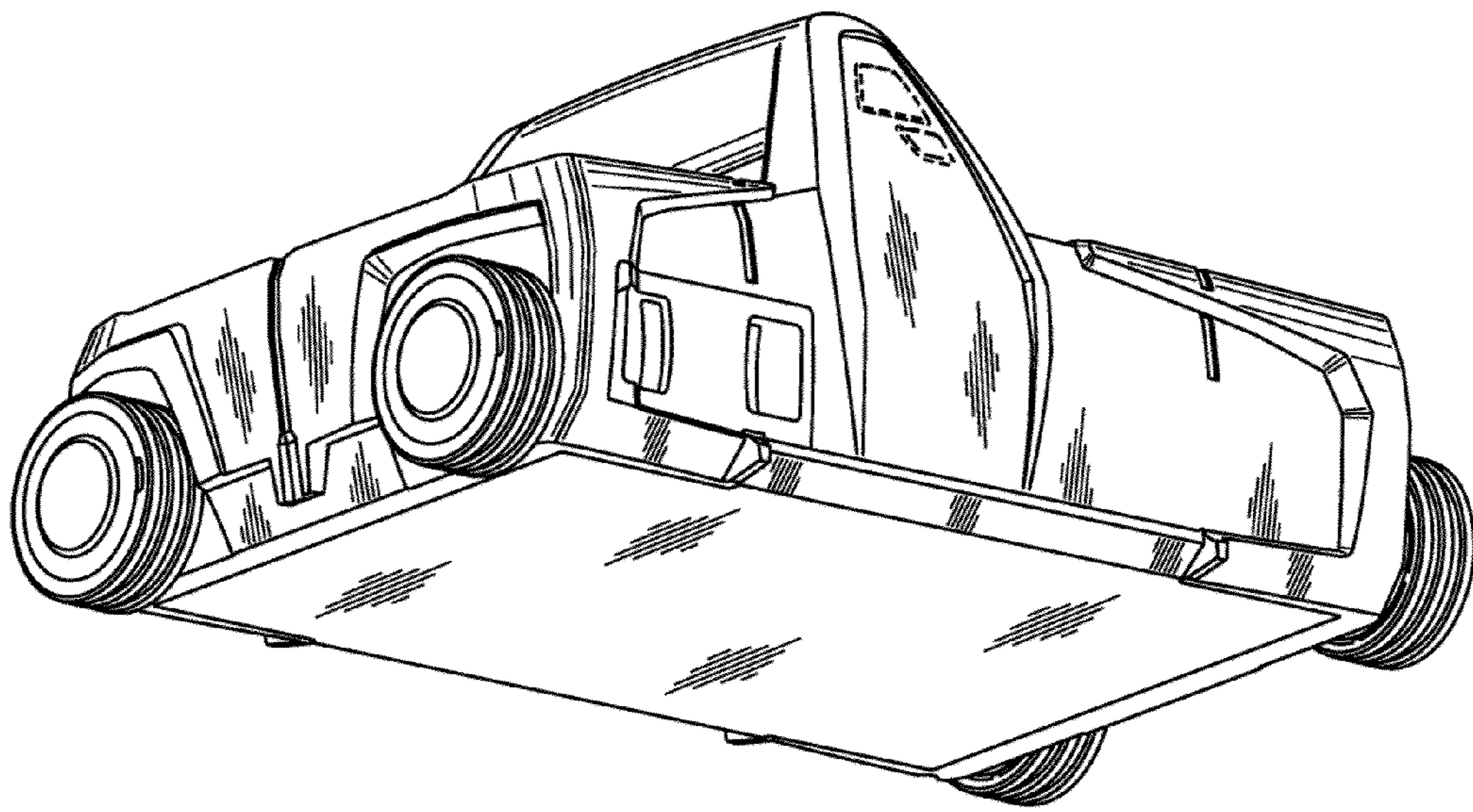

FIG. 2

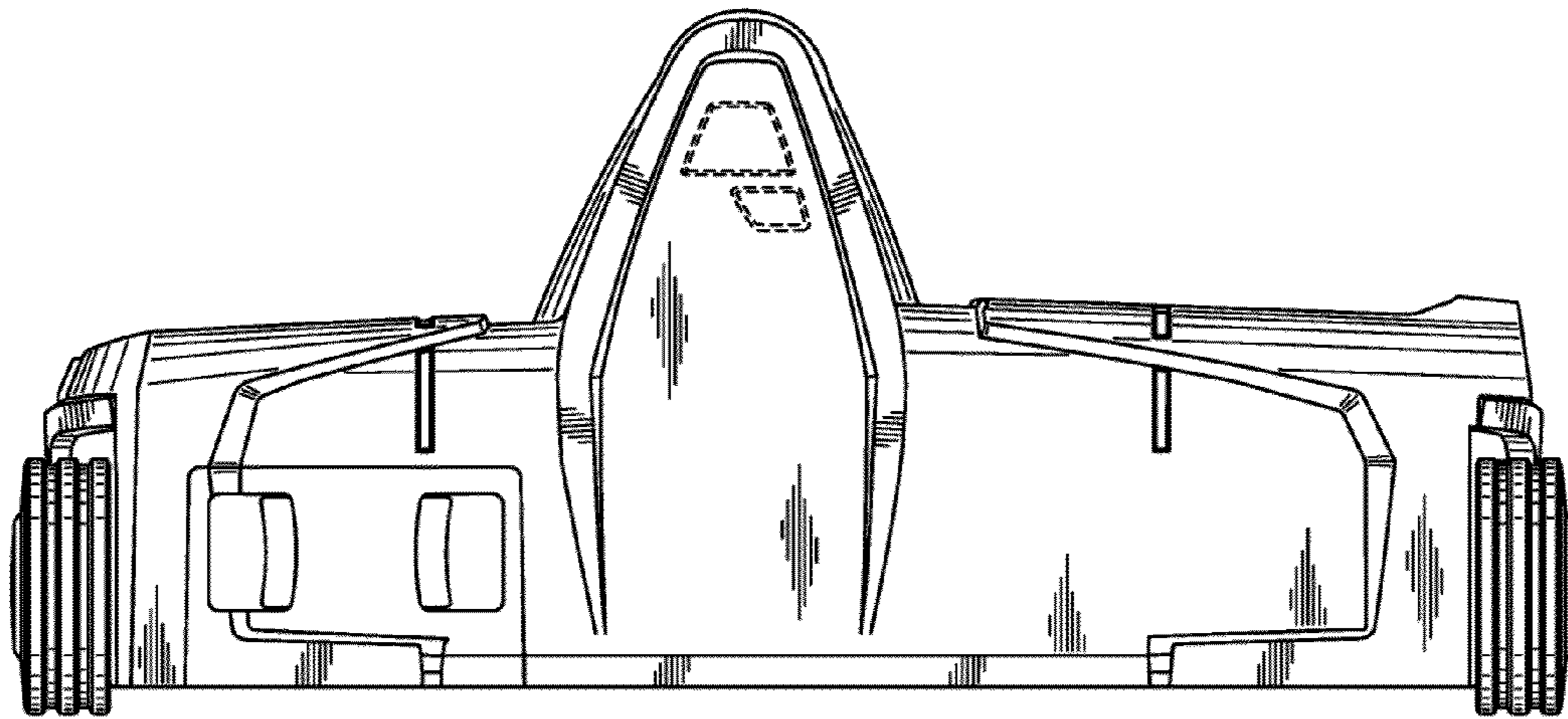

FIG. 3

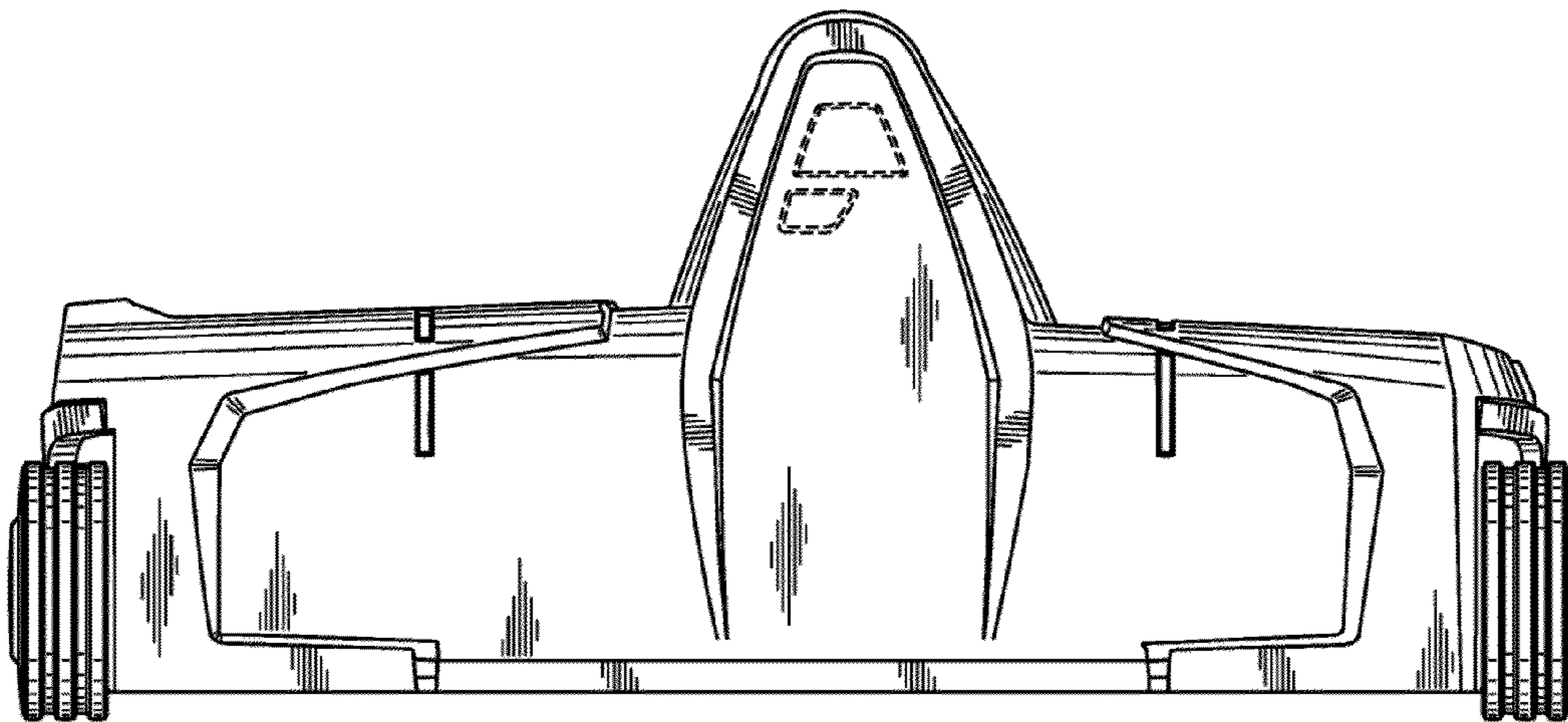

FIG. 4

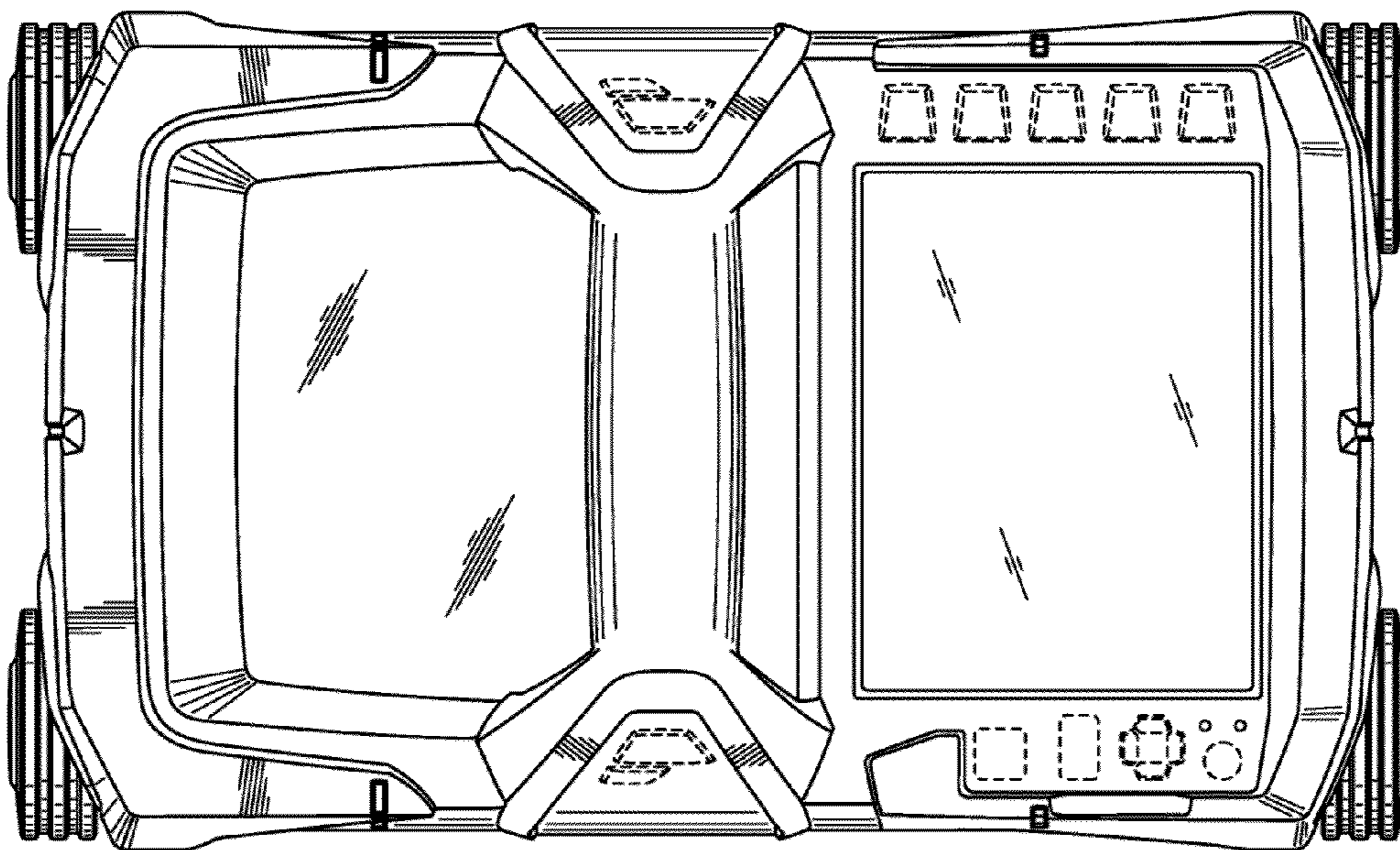

FIG. 5

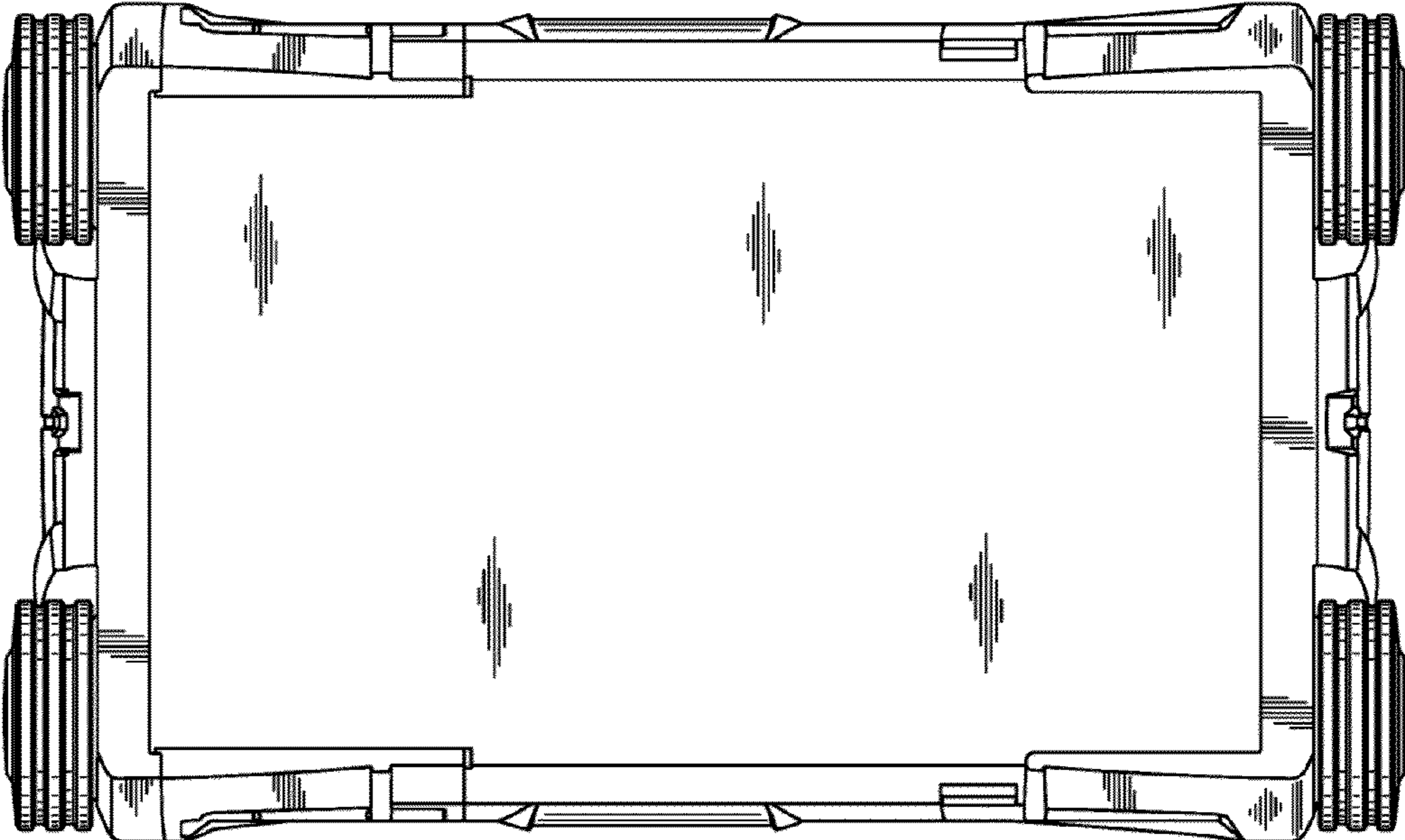

FIG. 6

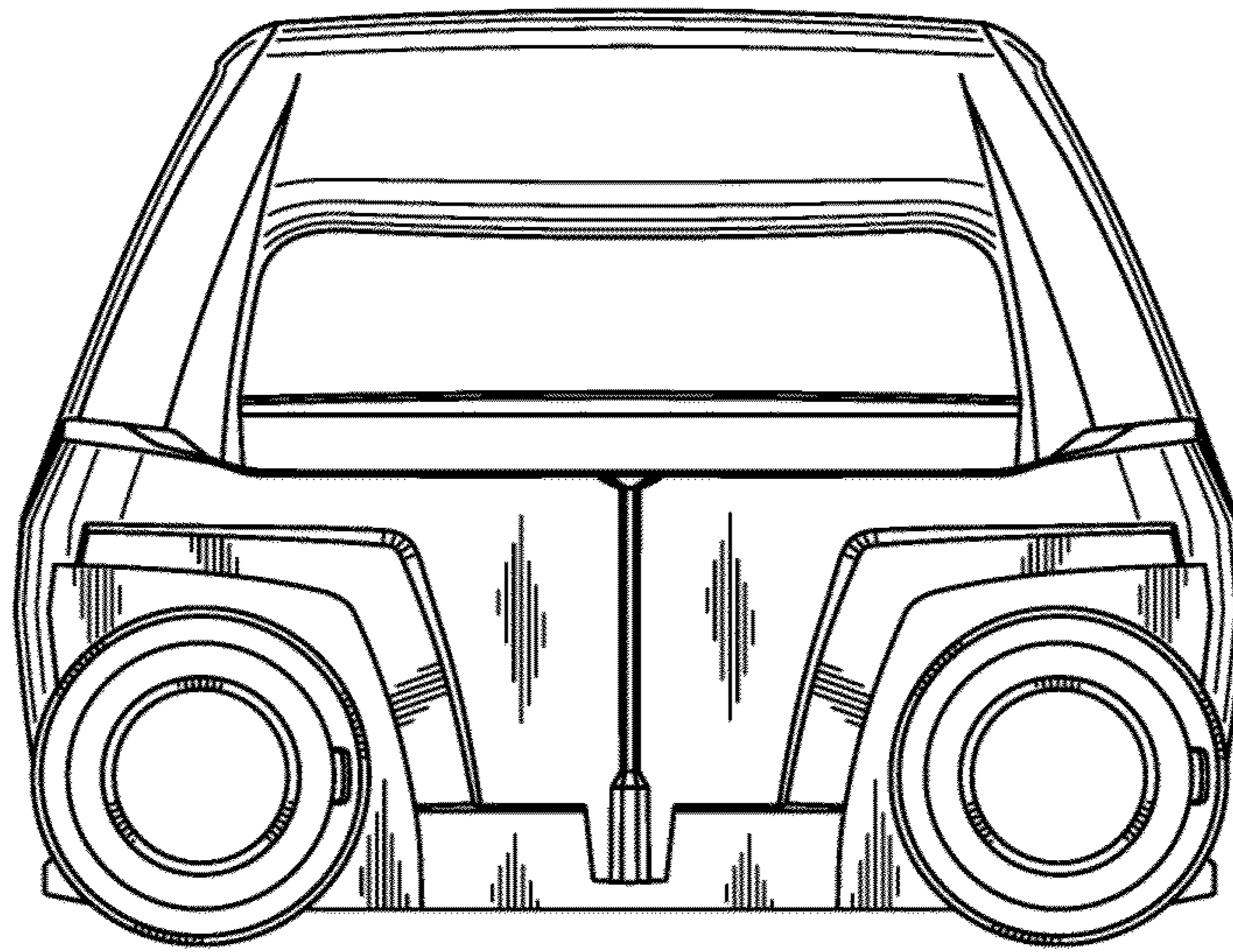

FIG. 7

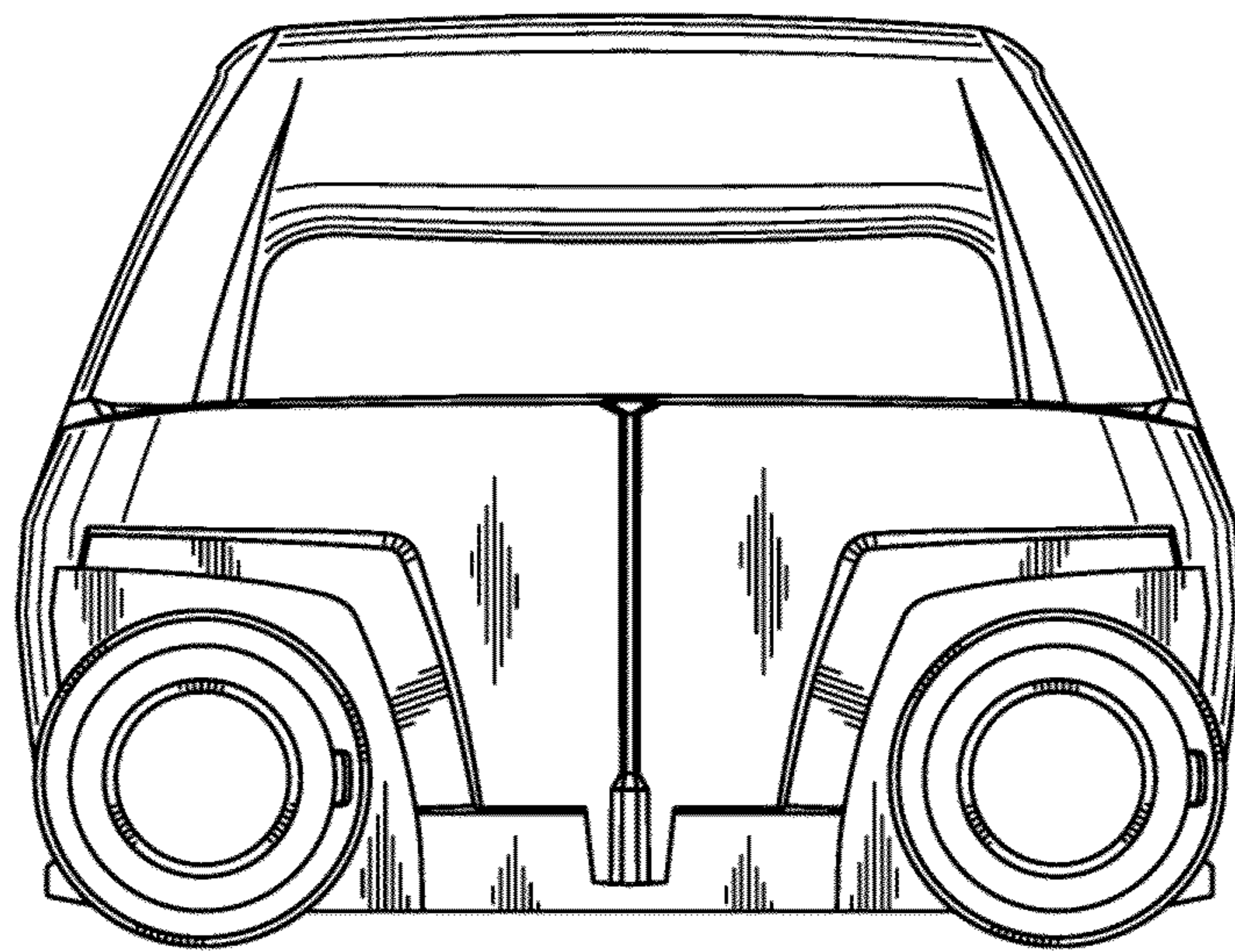

FIG. 8

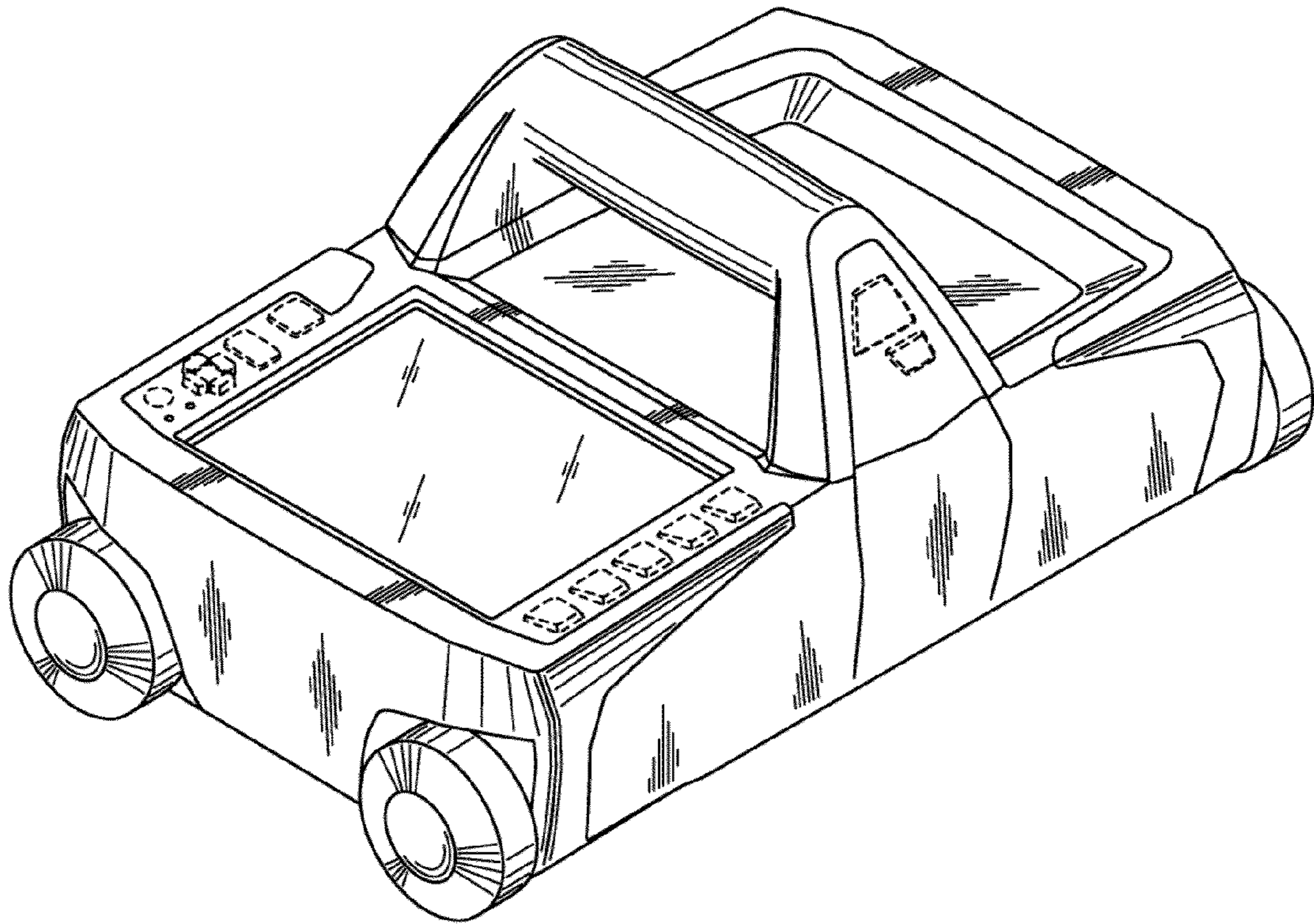

FIG. 9

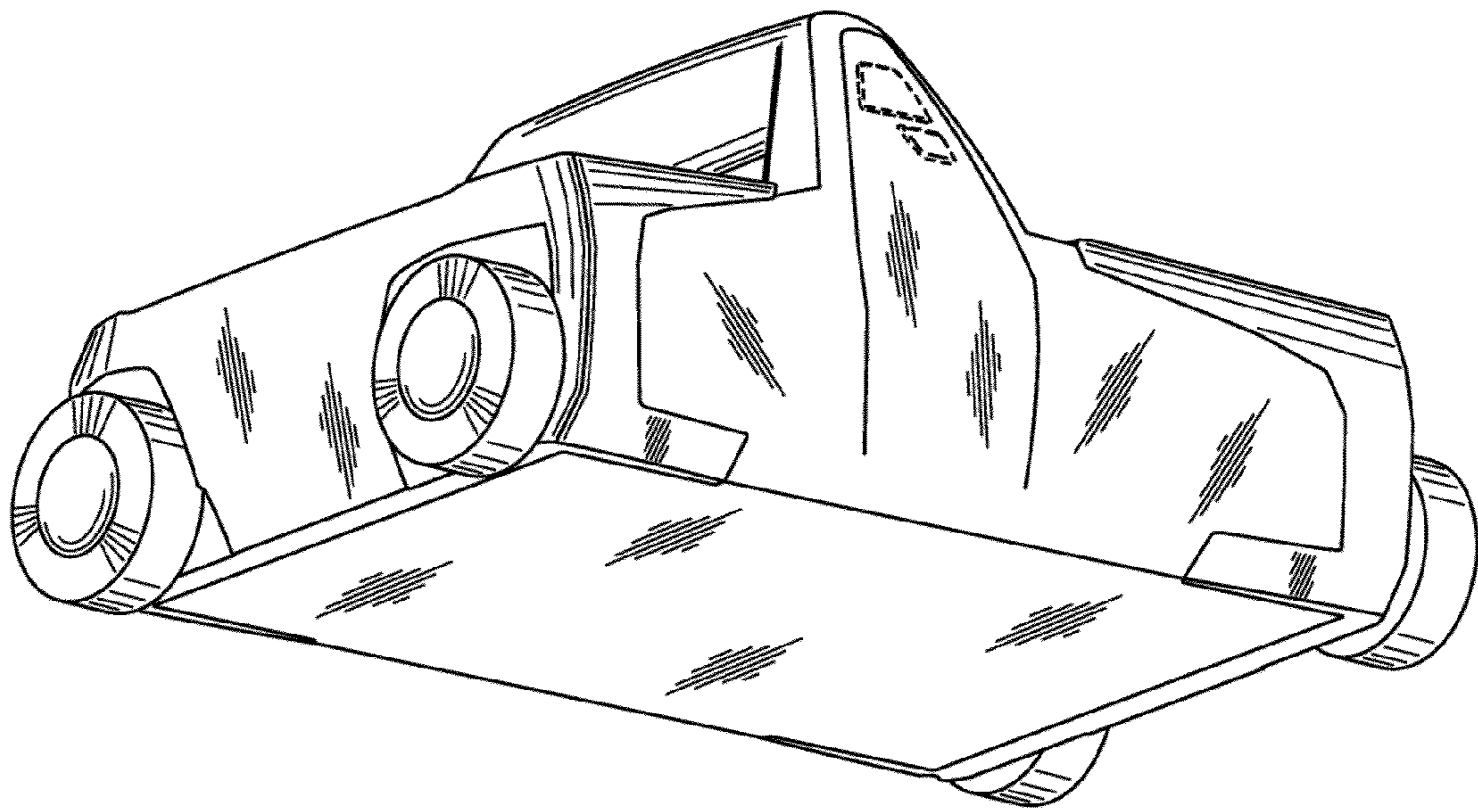

FIG. 10

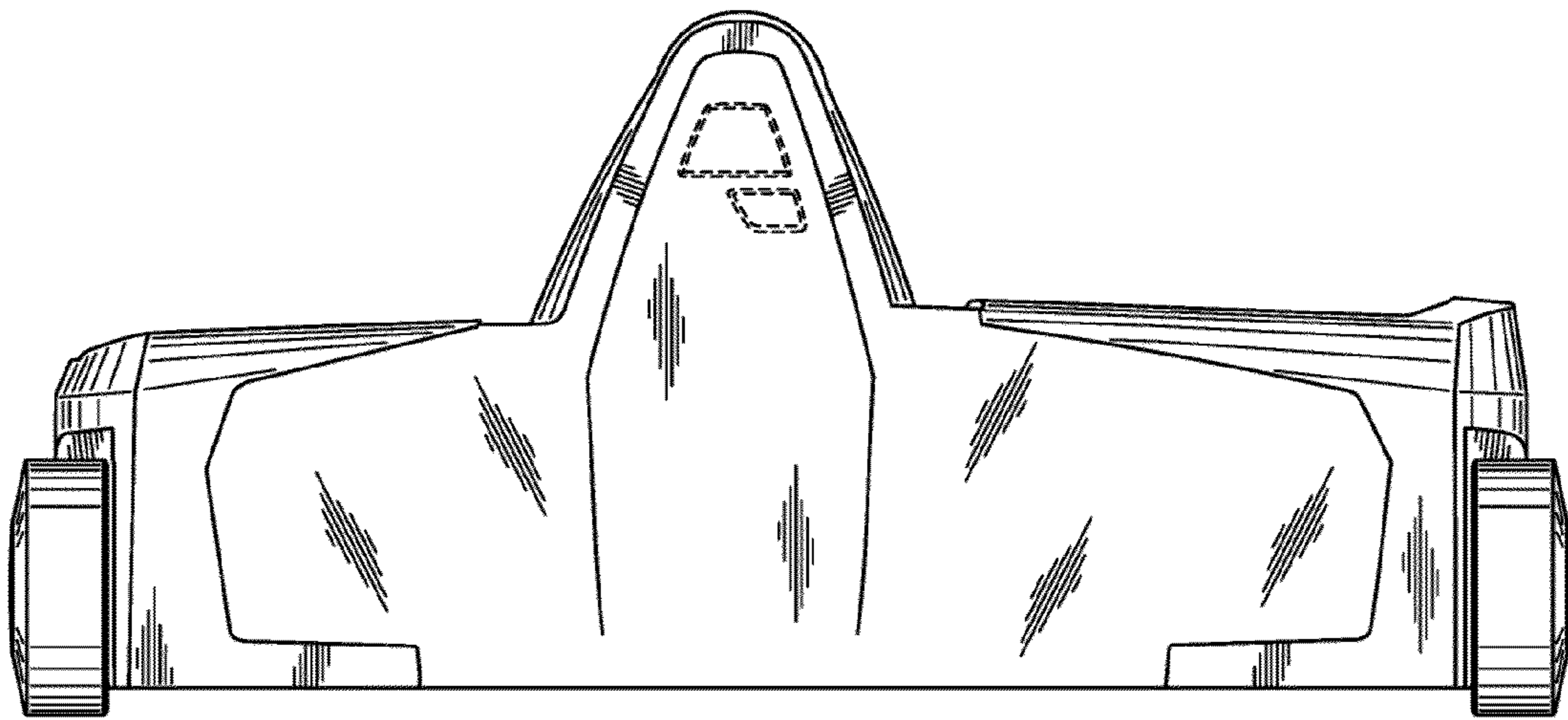

FIG. 11

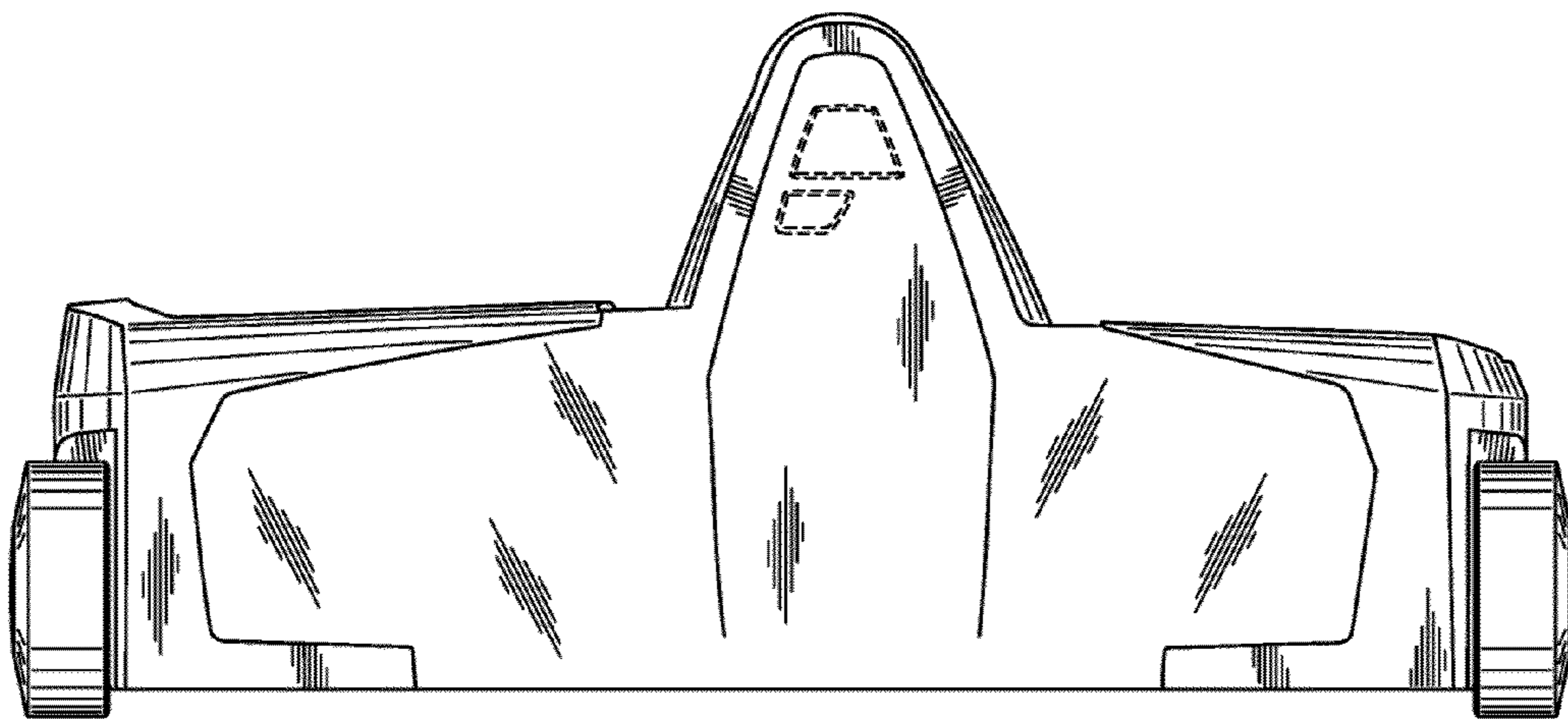

FIG. 12

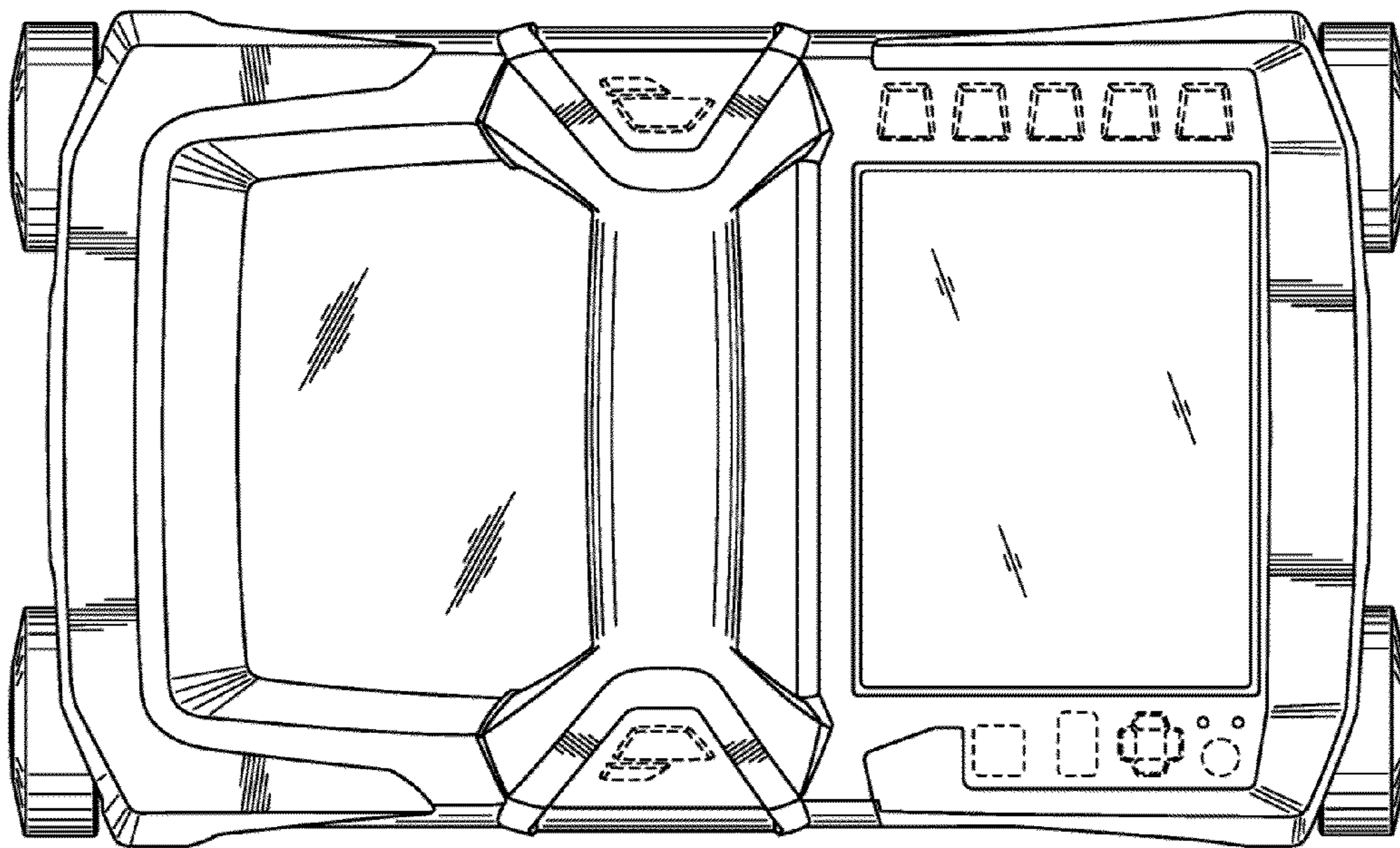

FIG. 13

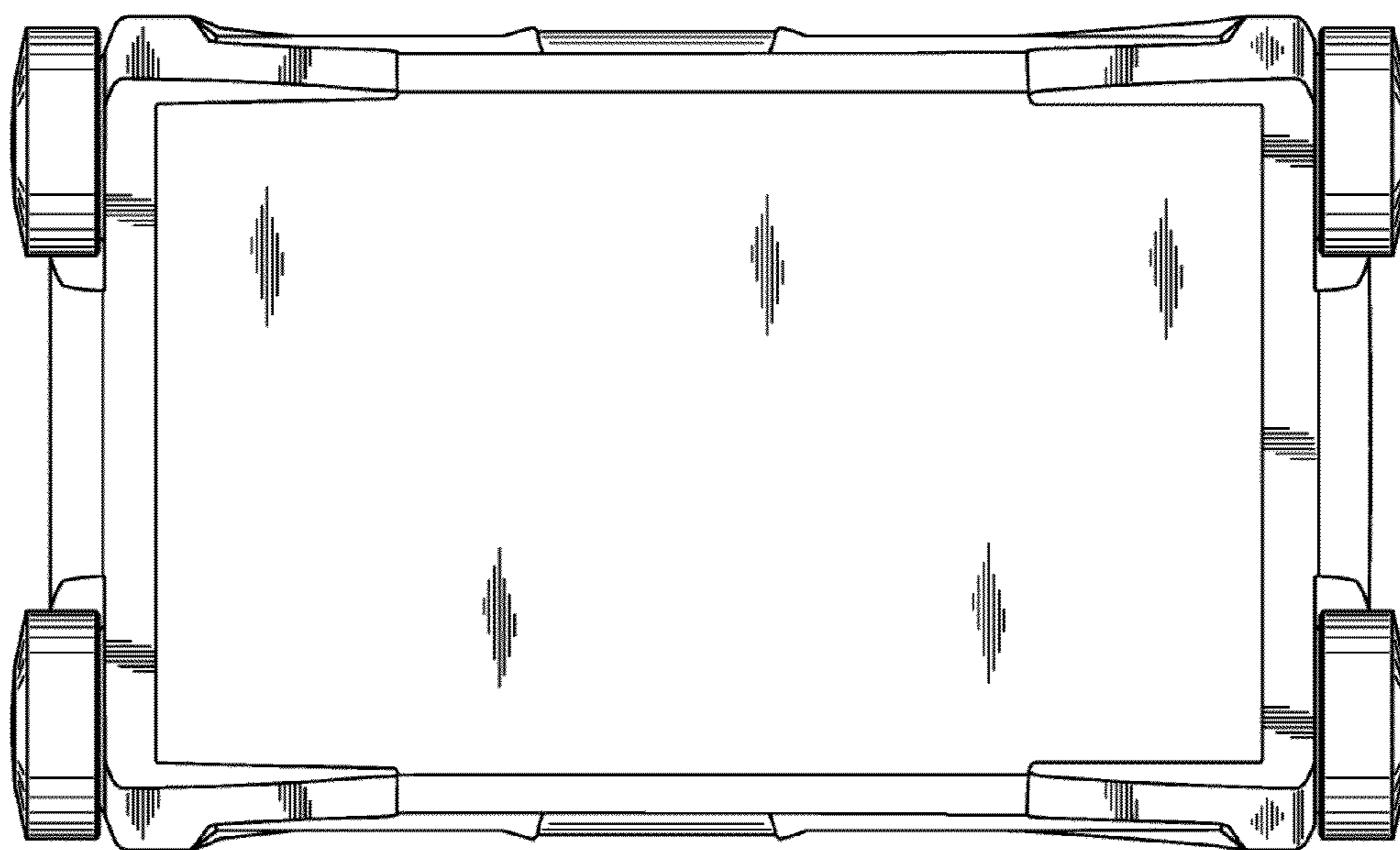

FIG. 14

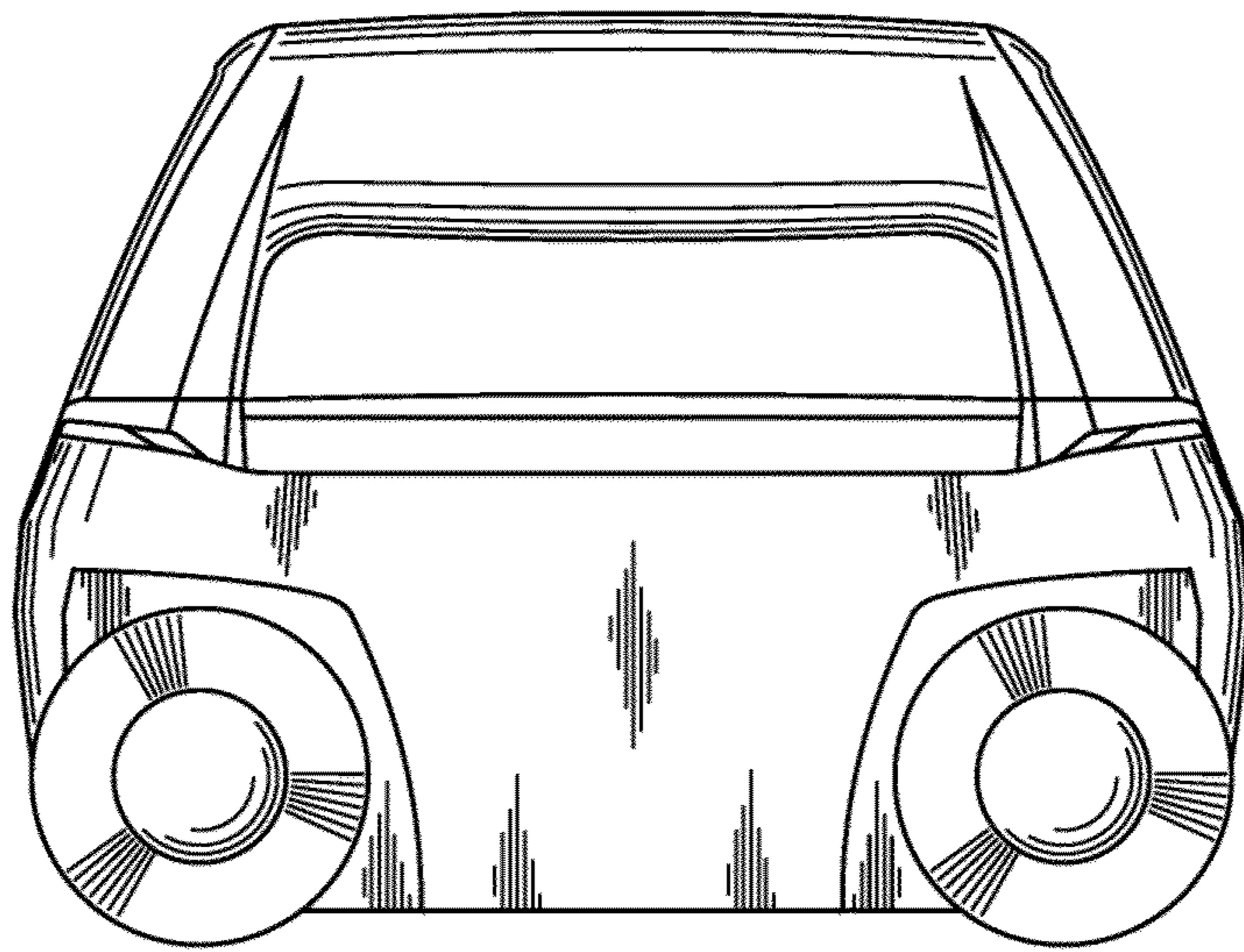

FIG. 15

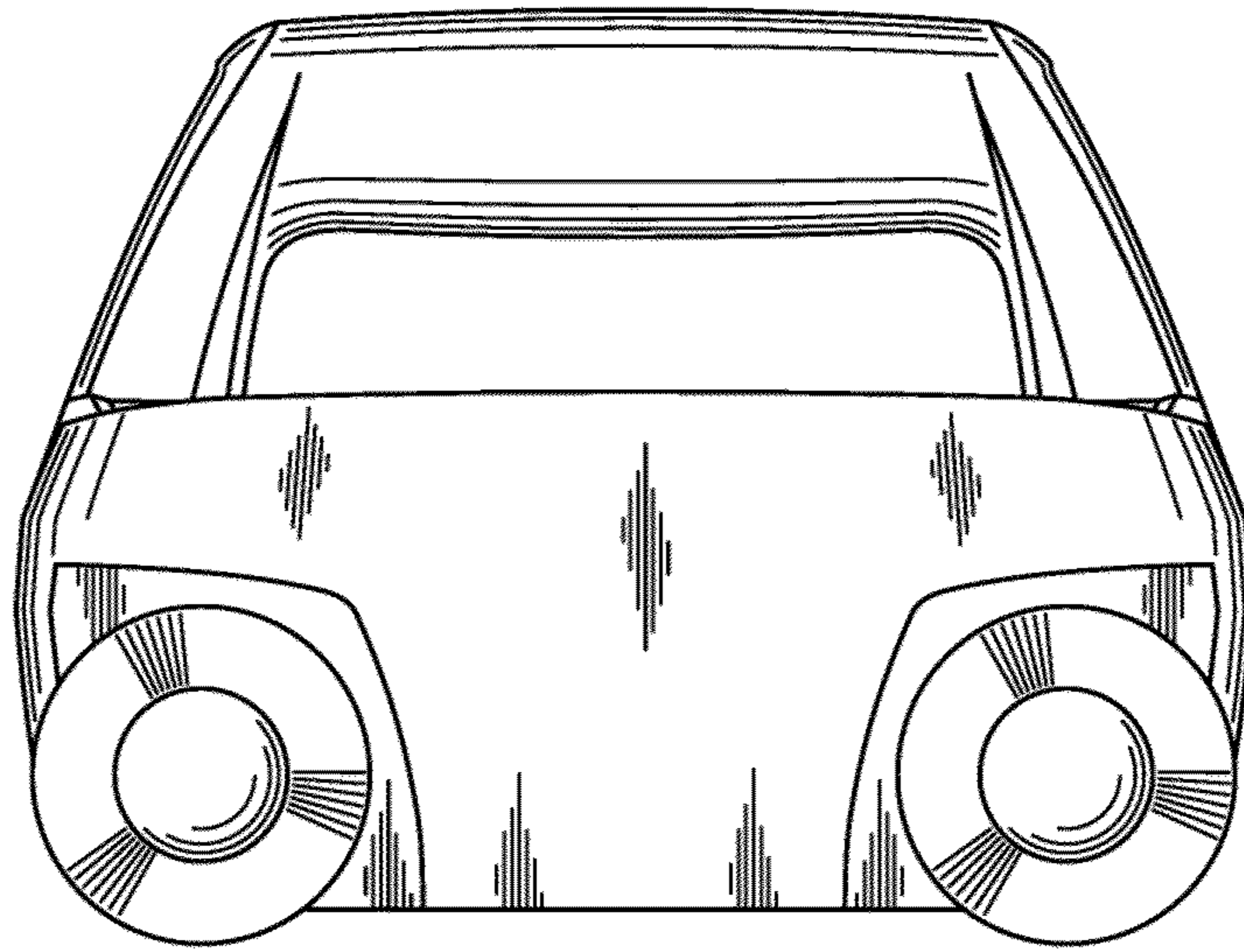

FIG. 16