



US00D684638S

(12) **United States Design Patent**
Shelley et al.

(10) **Patent No.:** **US D684,638 S**

(45) **Date of Patent:** **** Jun. 18, 2013**

(54) **GAMING MACHINE**

(56)

References Cited

(75) Inventors: **Scott Paul Shelley**, Heathcote (AU);
Vince Carmelo Bruzzese, Oatlands
(AU); **Peter Scott Clarebrough**,
Newington (AU)

U.S. PATENT DOCUMENTS

D464,377	S	*	10/2002	Wurz et al.	D21/369
D525,665	S	*	7/2006	Karlsson	D21/369
D563,481	S	*	3/2008	Looks et al.	D21/370
D594,068	S	*	6/2009	Hsu	D21/370
D626,603	S	*	11/2010	Bruzzese et al.	D21/370
7,927,218	B2	*	4/2011	Kopera et al.	463/20

(73) Assignee: **Ainsworth Game Technology Limited**,
Newington, New South Wales (AU)

* cited by examiner

(**) Term: **14 Years**

Primary Examiner — Sandra Morris

(21) Appl. No.: **29/408,965**

(74) *Attorney, Agent, or Firm* — Gottlieb, Rackman &
Reisman, P.C.

(22) Filed: **Dec. 19, 2011**

(57)

CLAIM

The ornamental design for a gaming machine, as shown and
described.

(30) **Foreign Application Priority Data**

DESCRIPTION

Jun. 29, 2011 (AU) 12902/2011

(51) **LOC (9) Cl.** **21-03**

(52) **U.S. Cl.**

USPC **D21/370**

(58) **Field of Classification Search**

USPC D21/324–329, 369–370, 385; 463/16–17,
463/20, 31, 46–47

FIG. 1 is a front, top, left side perspective view of a gaming
machine showing my new design;
FIG. 2 is a front view thereof;
FIG. 3 is a rear view thereof;
FIG. 4 is a right side view thereof;
FIG. 5 is a left side view thereof;
FIG. 6 is a top plan view thereof; and,
FIG. 7 is a bottom plan view thereof.

See application file for complete search history.

1 Claim, 7 Drawing Sheets

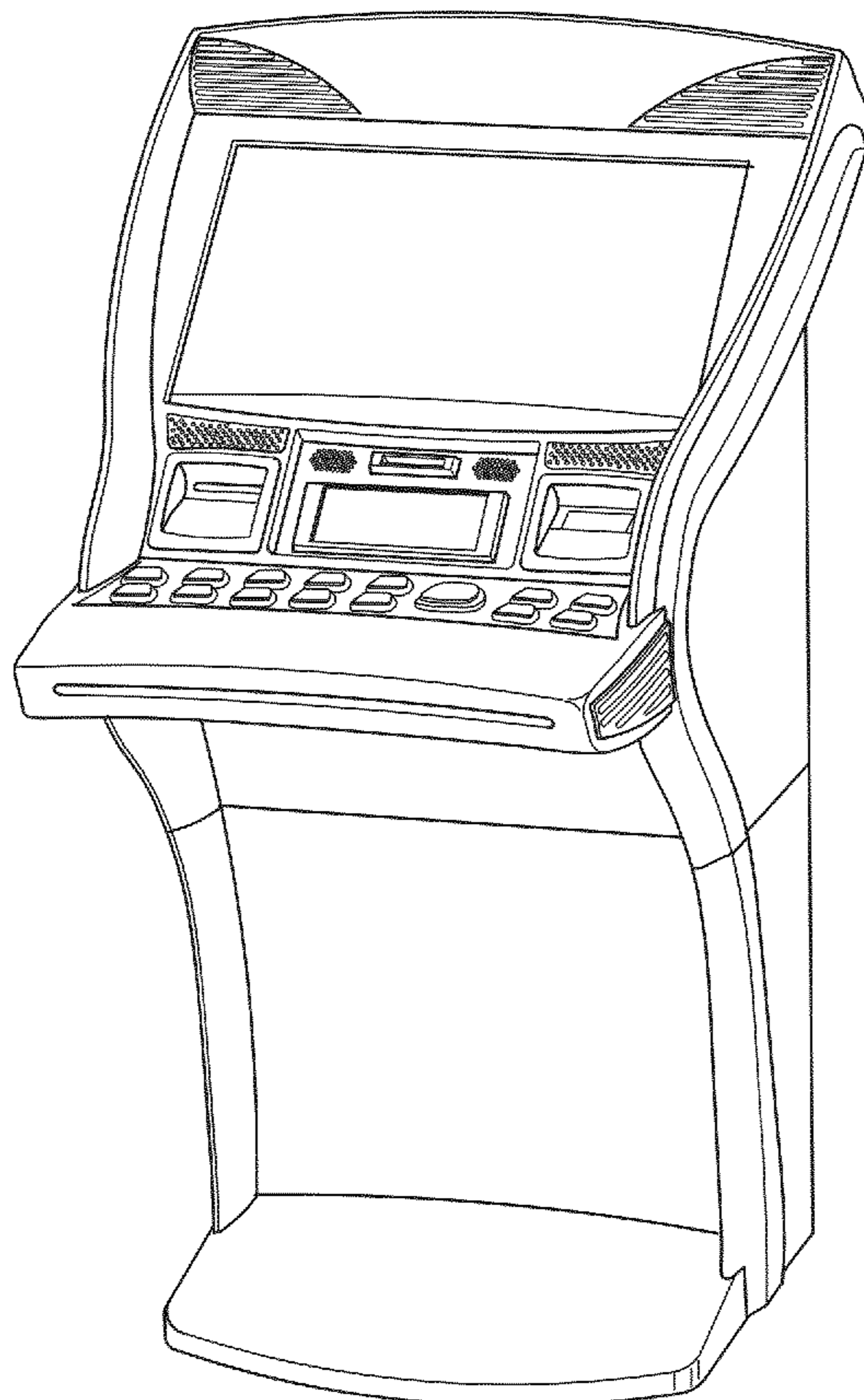

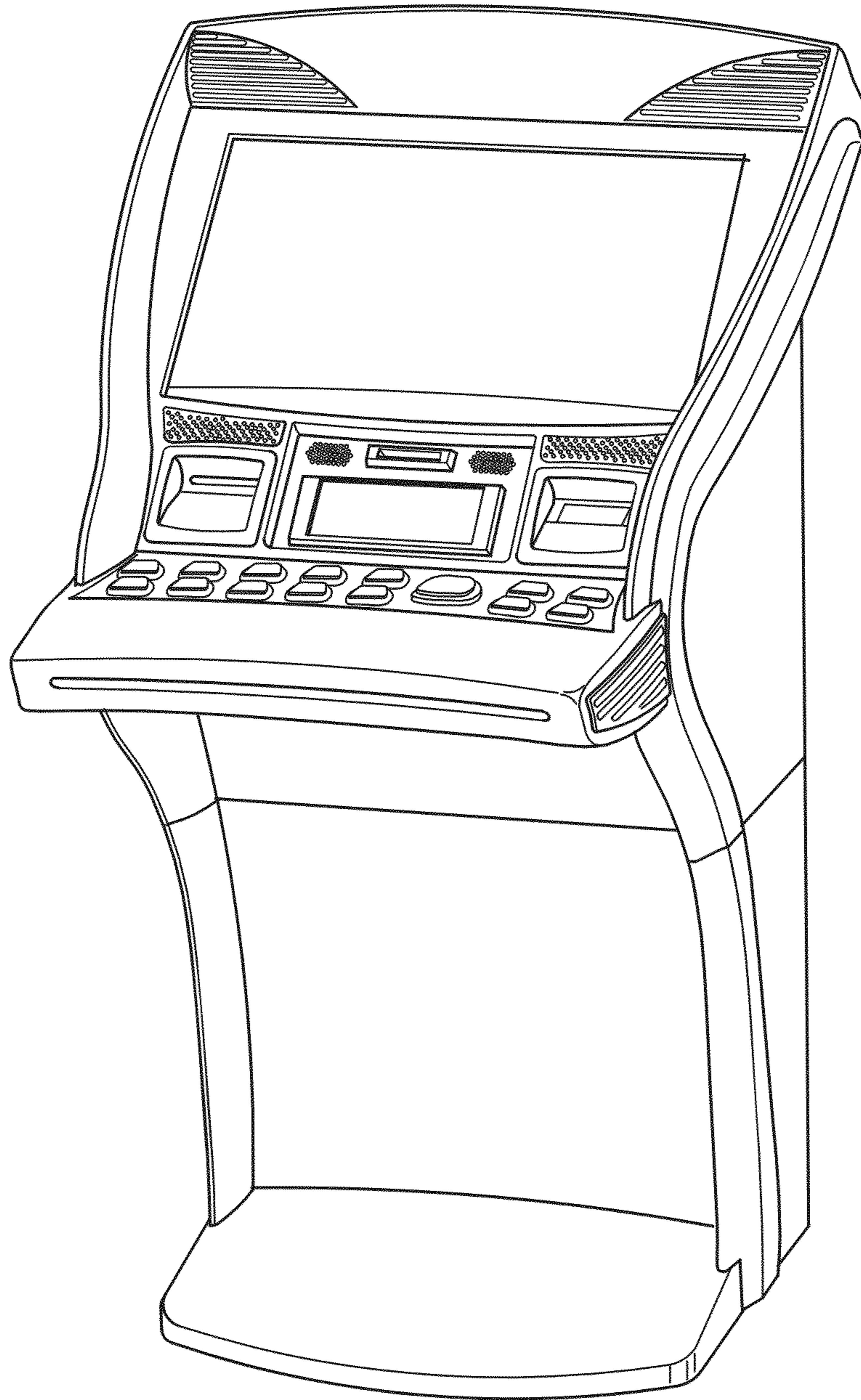

FIG. 1

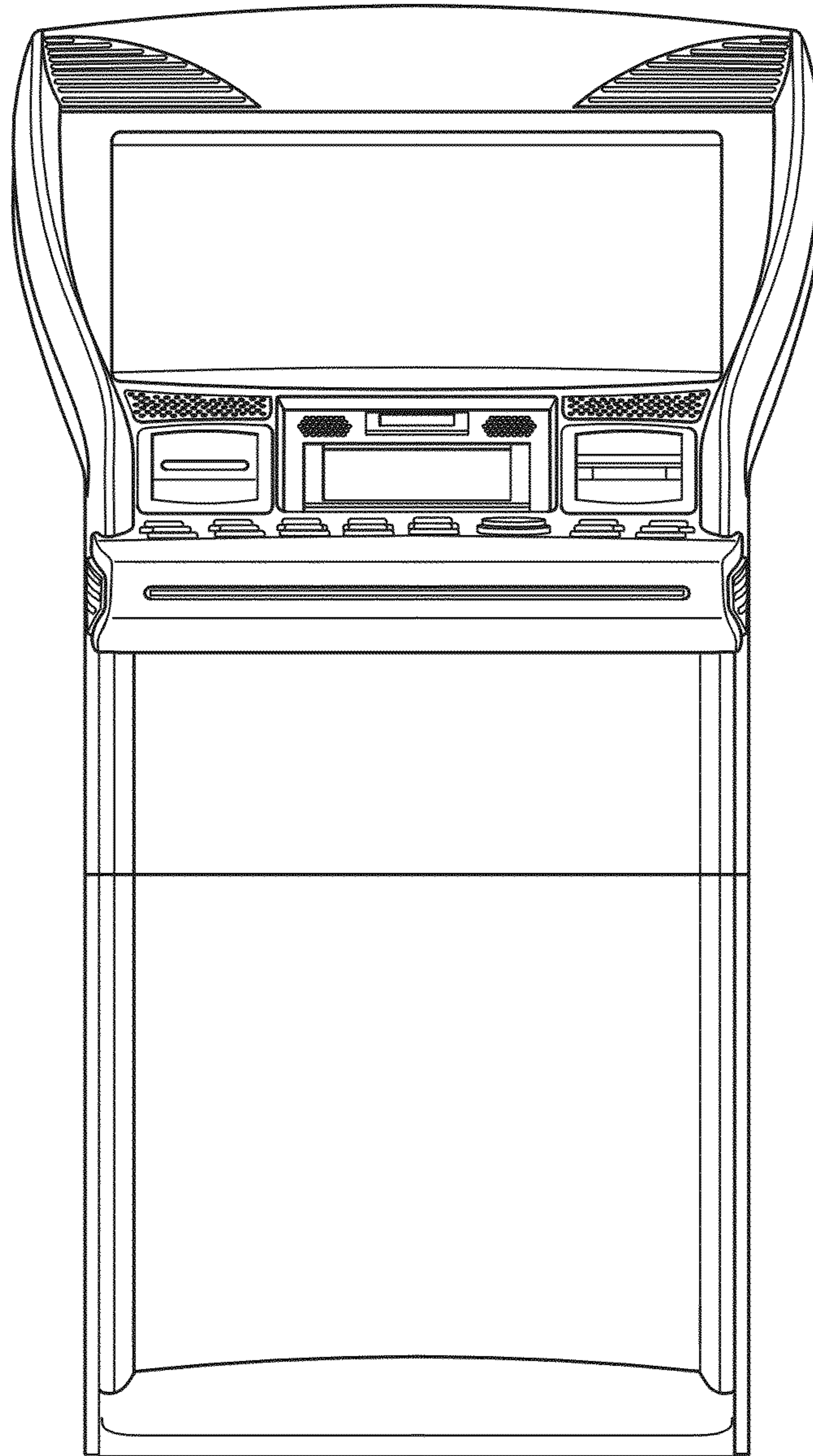

FIG. 2

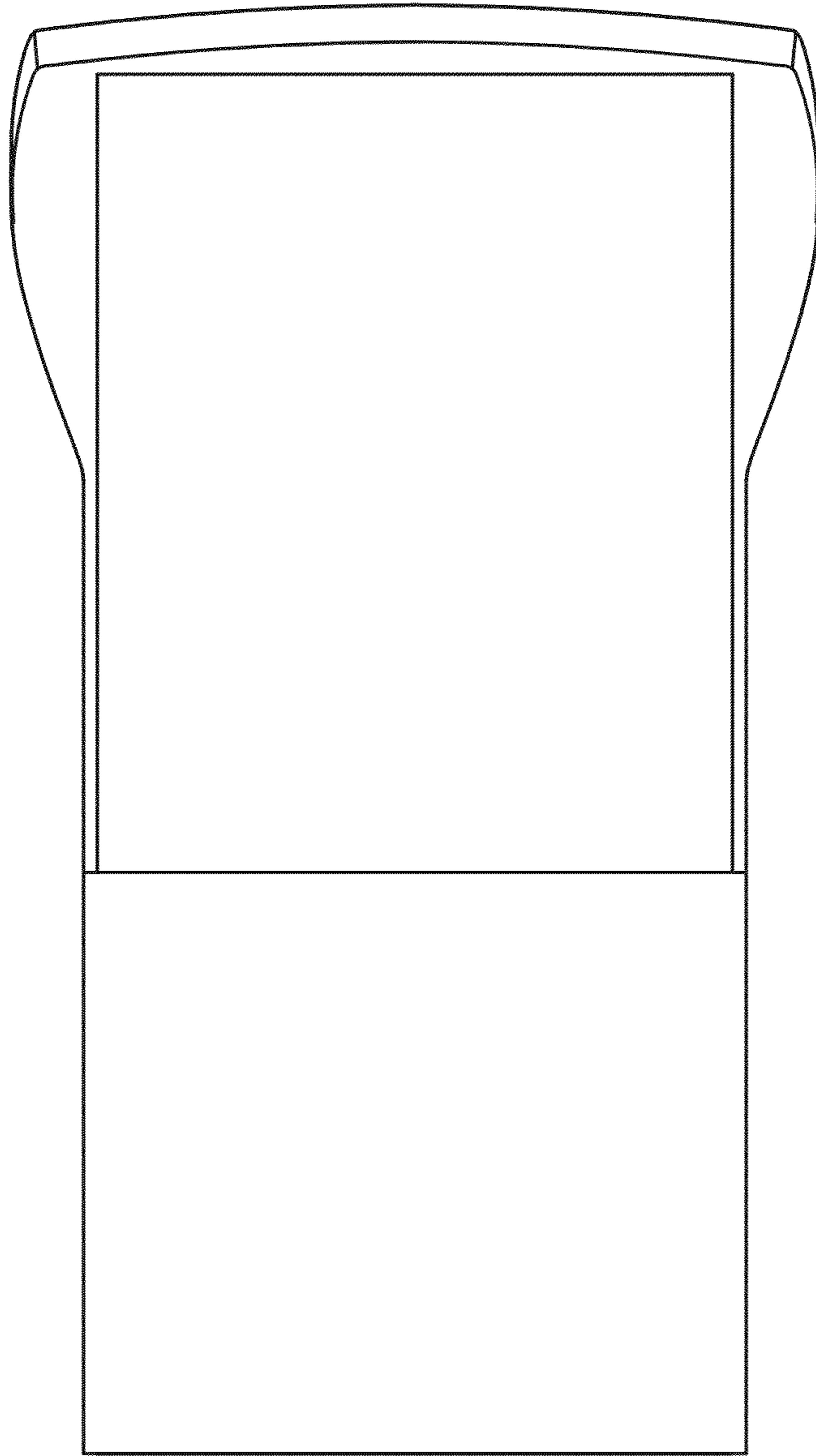

FIG. 3

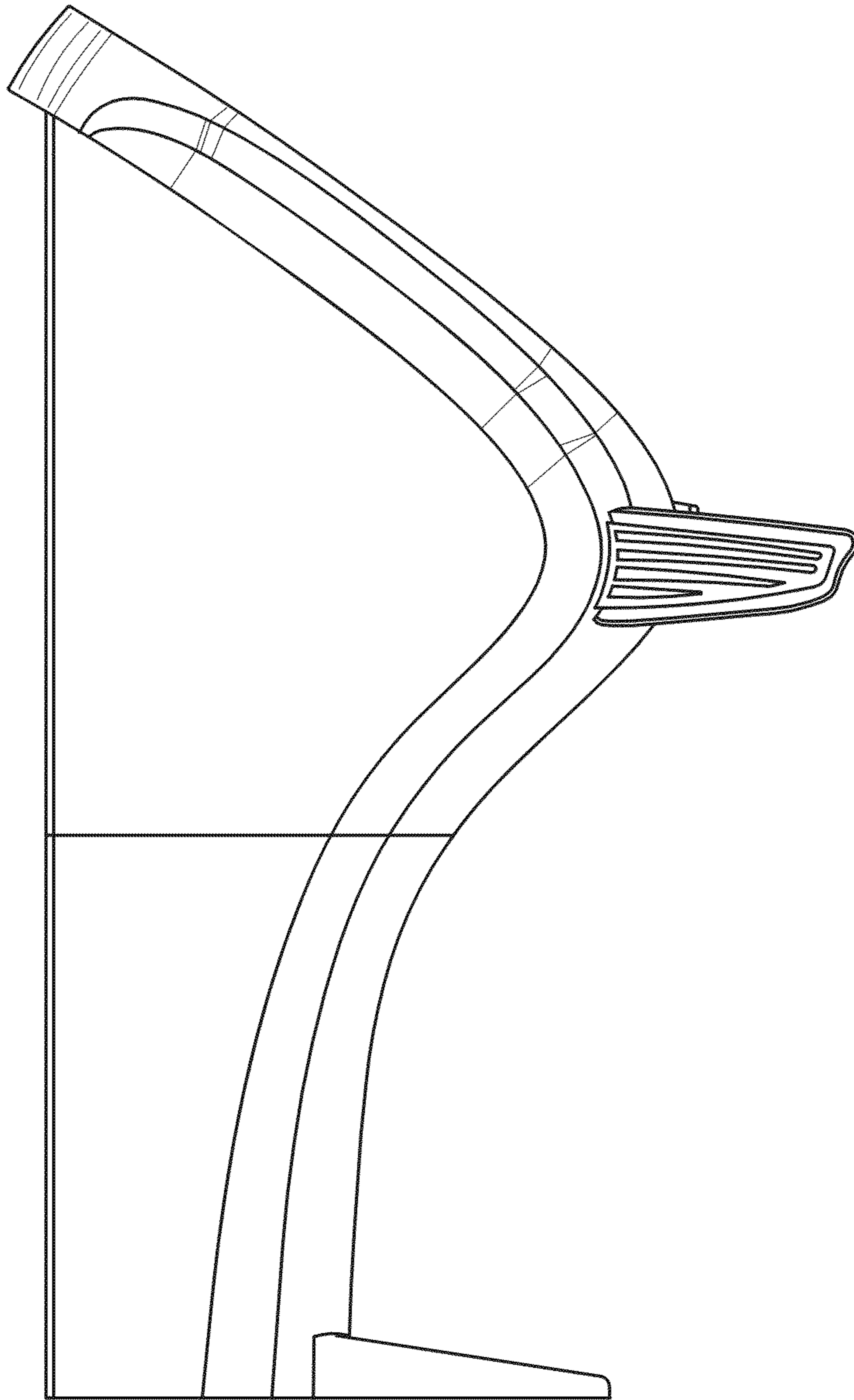

FIG. 4

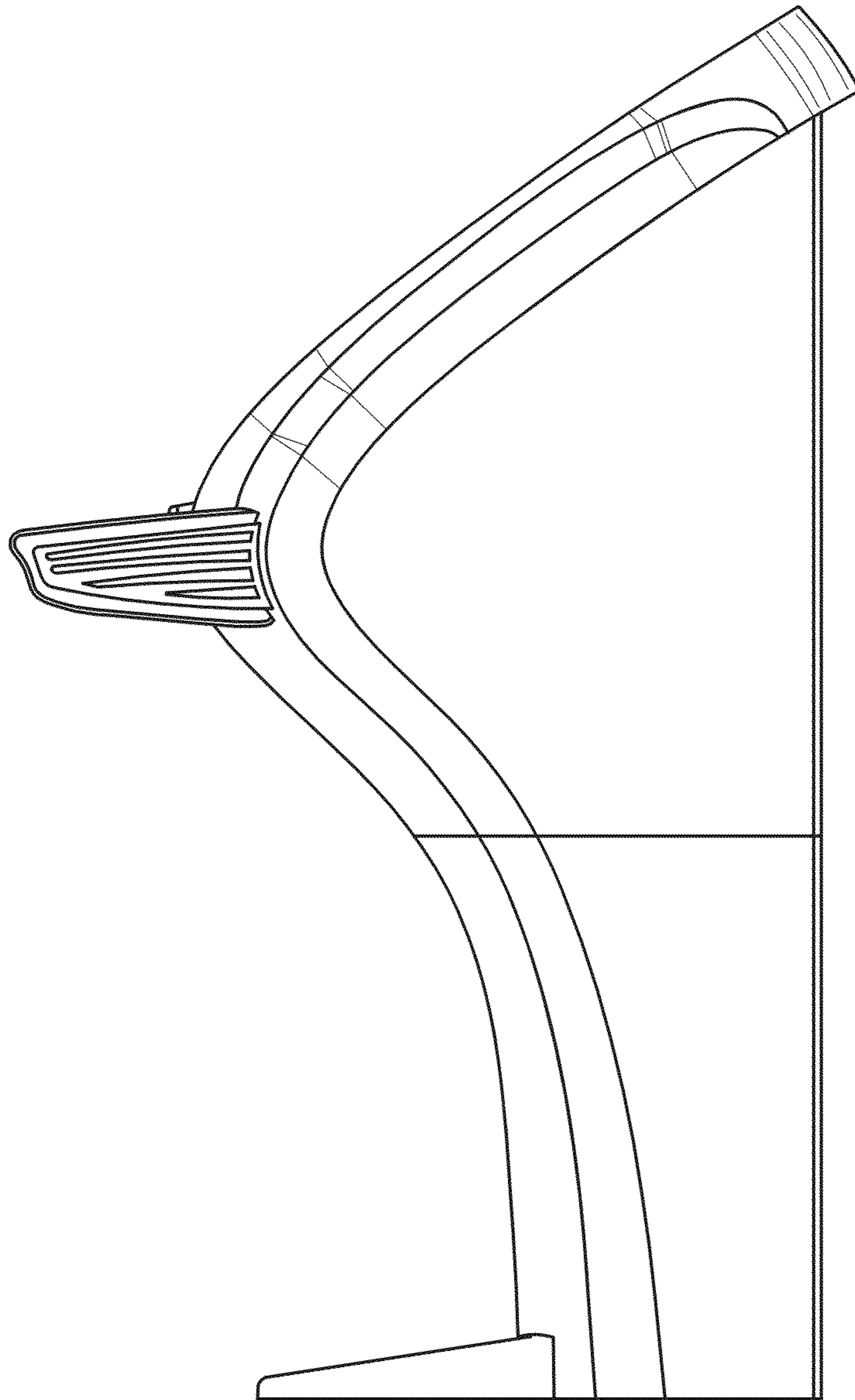

FIG. 5

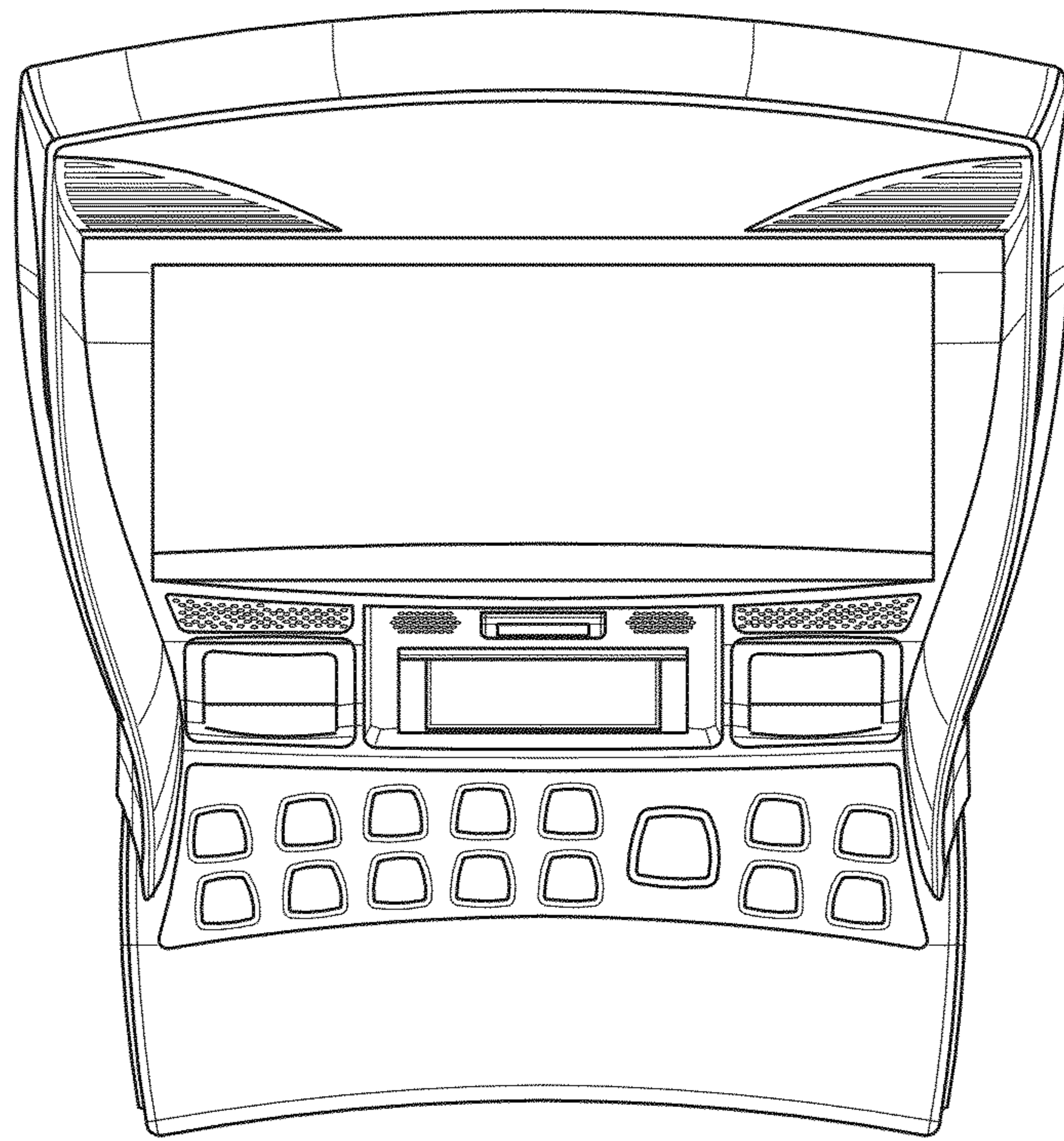

FIG. 6

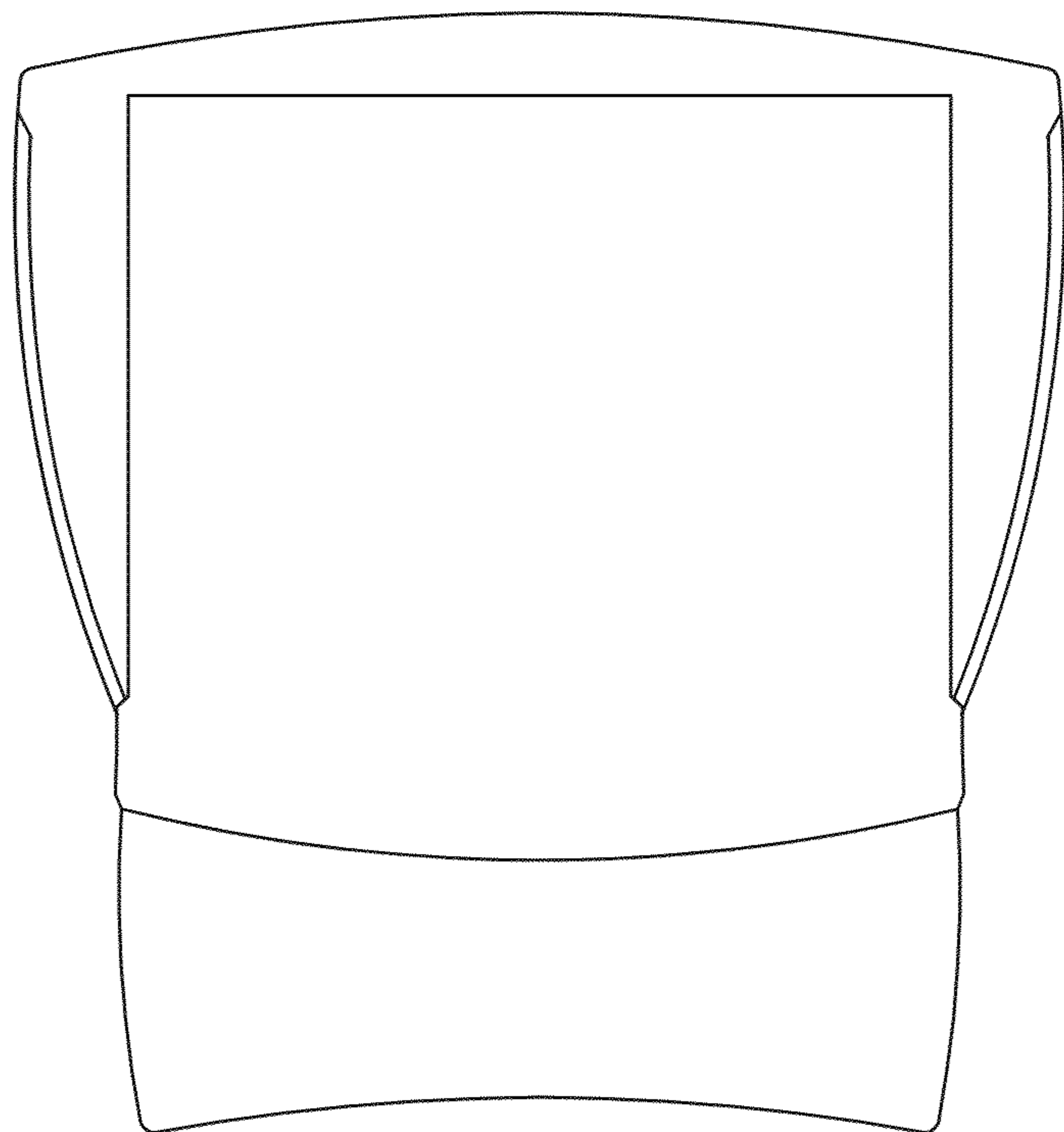

FIG. 7