



US00D683702S

(12) **United States Design Patent**
Kaneshige

(10) **Patent No.:** **US D683,702 S**

(45) **Date of Patent:** **** Jun. 4, 2013**

(54) **CONTROL UNIT FOR A BATTERY MODULE**

(75) **Inventor:** **Masahiro Kaneshige, Hitachinaka (JP)**

(73) **Assignee:** **Hitachi Vehicle Energy, Ltd, Ibaraki (JP)**

(**) **Term:** **14 Years**

(21) **Appl. No.:** **29/385,497**

(22) **Filed:** **Feb. 15, 2011**

(30) **Foreign Application Priority Data**

Sep. 28, 2010 (JP) 2010-023172

(51) **LOC (9) Cl.** **13-03**

(52) **U.S. Cl.**
USPC **D13/147**

(58) **Field of Classification Search**
USPC D13/107, 108, 118, 119, 120, 147,
D13/154, 156, 184, 199; 439/278, 374, 378,
439/379, 381, 754, 756, 757, 772, 892, 894,
439/901, 902, 904, 919

See application file for complete search history.

(56) **References Cited**

U.S. PATENT DOCUMENTS

D317,437 S * 6/1991 Ogawa D13/147
D331,546 S * 12/1992 Pringle D10/106.6
D396,474 S * 7/1998 Lin D14/256
D396,690 S * 8/1998 Fryers D13/147
D413,323 S * 8/1999 Tashiro D14/357

D421,964 S * 3/2000 Nagasawa et al. D13/147
D424,523 S * 5/2000 Hughes D13/147
D607,821 S * 1/2010 Fukano et al. D13/146
D642,516 S * 8/2011 Ueda et al. D13/103

FOREIGN PATENT DOCUMENTS

JP D 977264 S 3/1997
JP D 1318847 S 1/2008

OTHER PUBLICATIONS

Copending U.S. Appl. No. 29/385,502, filed Feb. 15, 2011, Kaneshige.

* cited by examiner

Primary Examiner — Daniel D. Bui

(74) *Attorney, Agent, or Firm* — Antonelli, Terry, Stout & Kraus, LLP.

(57) **CLAIM**

I claim the ornamental design for a control unit for a battery module, as shown and described.

DESCRIPTION

FIG. 1 is a front, bottom and left side perspective view of a control unit for a battery module showing my new design; FIG. 2 is a front elevational view thereof; FIG. 3 is a rear elevational view thereof; FIG. 4 is a top plan view thereof; FIG. 5 is a bottom plan view thereof; FIG. 6 is a left side elevational view thereof; and, FIG. 7 is a right side elevational view thereof. The broken line in the figure drawings is included for the purpose of illustrating environment and forms no part of the claimed design.

1 Claim, 5 Drawing Sheets

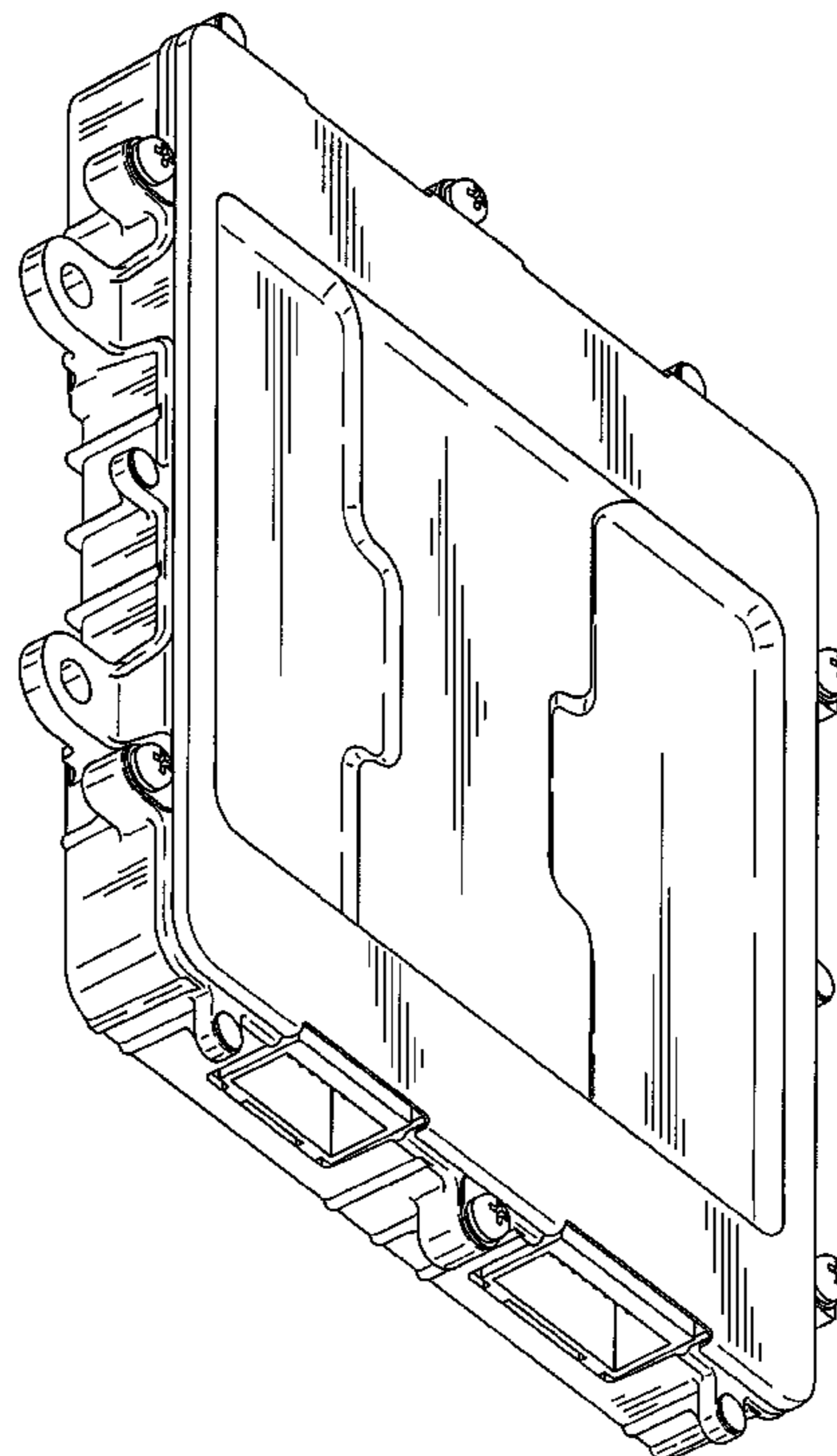

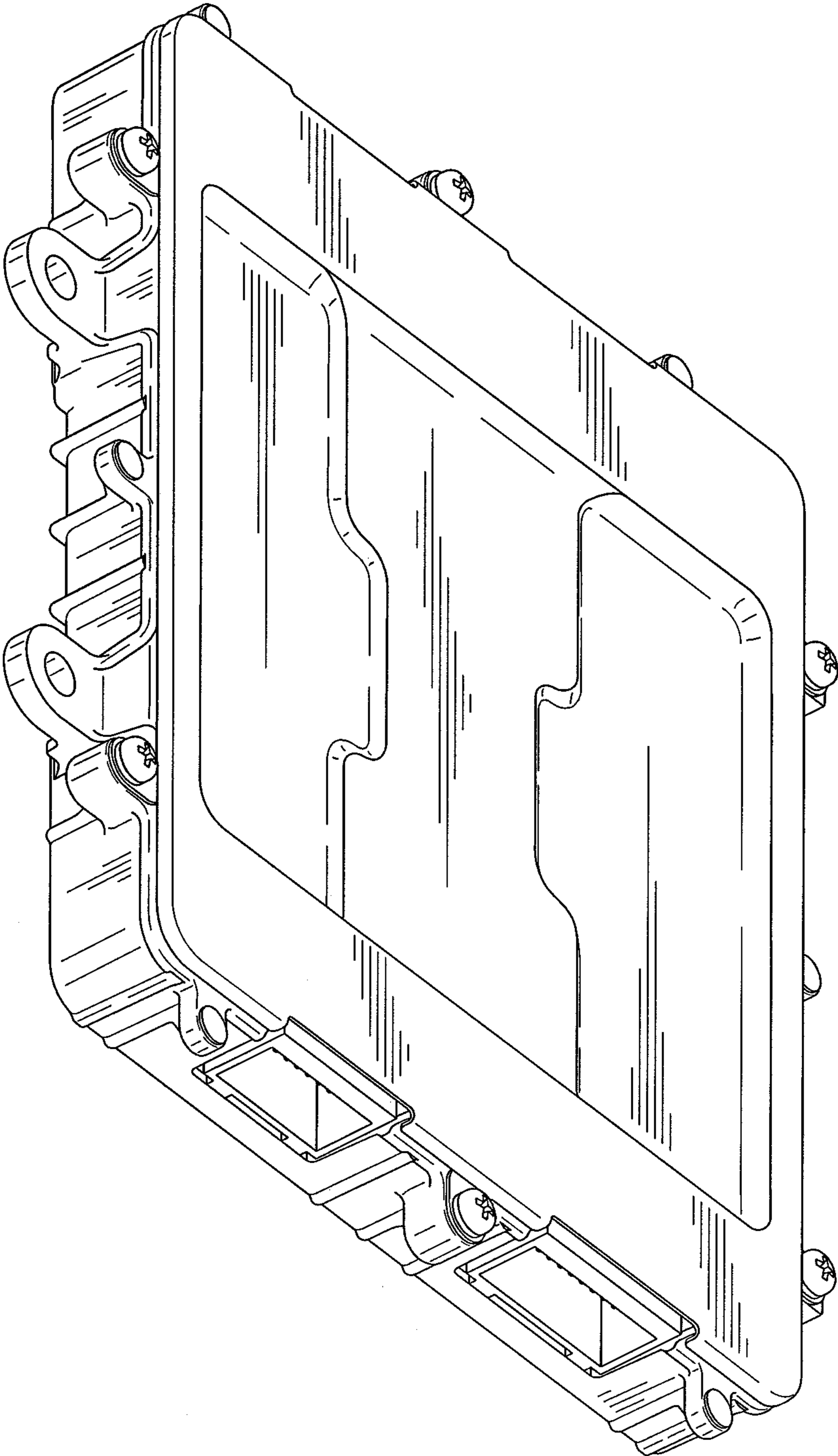

FIG. 1

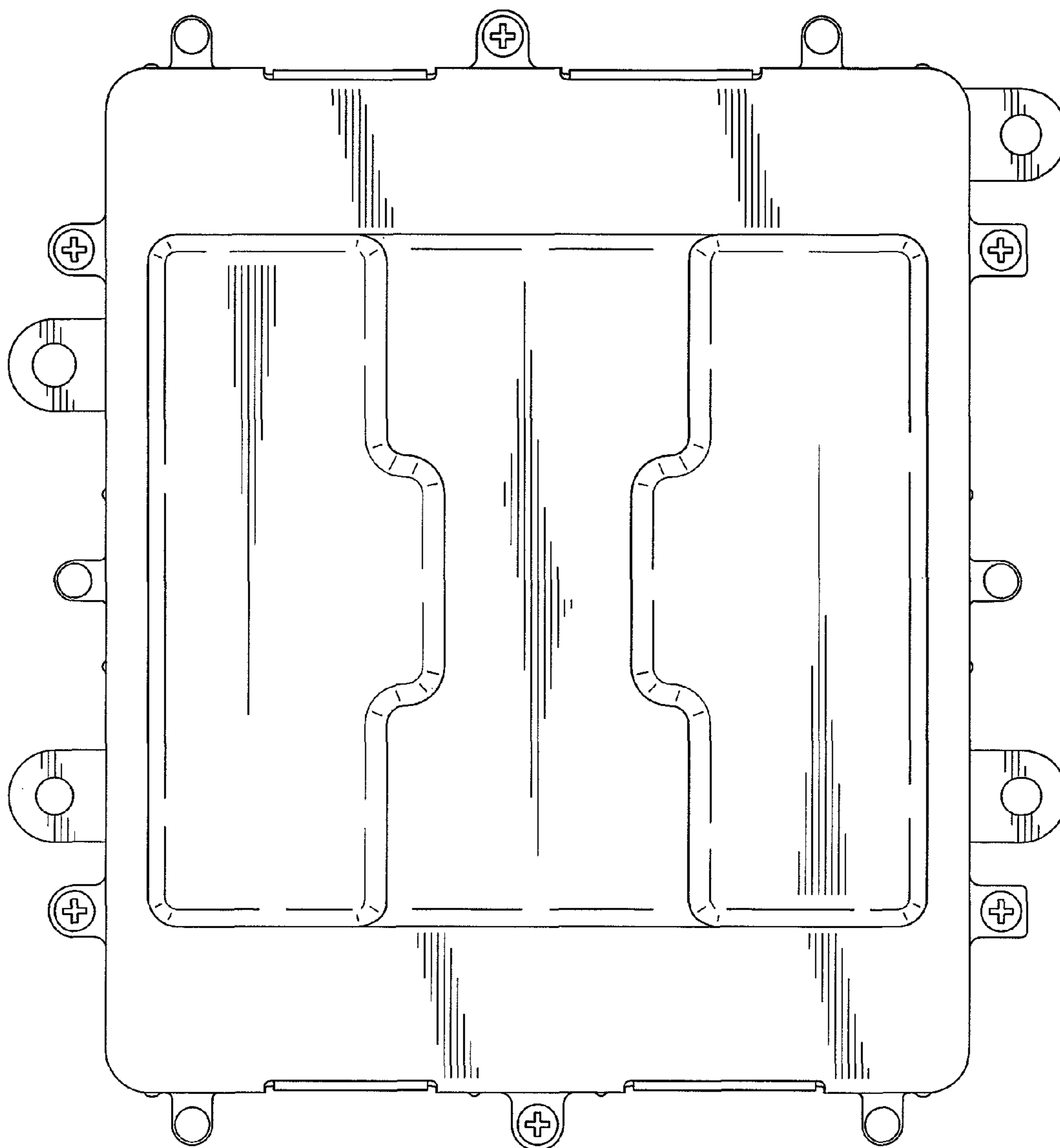

FIG. 2

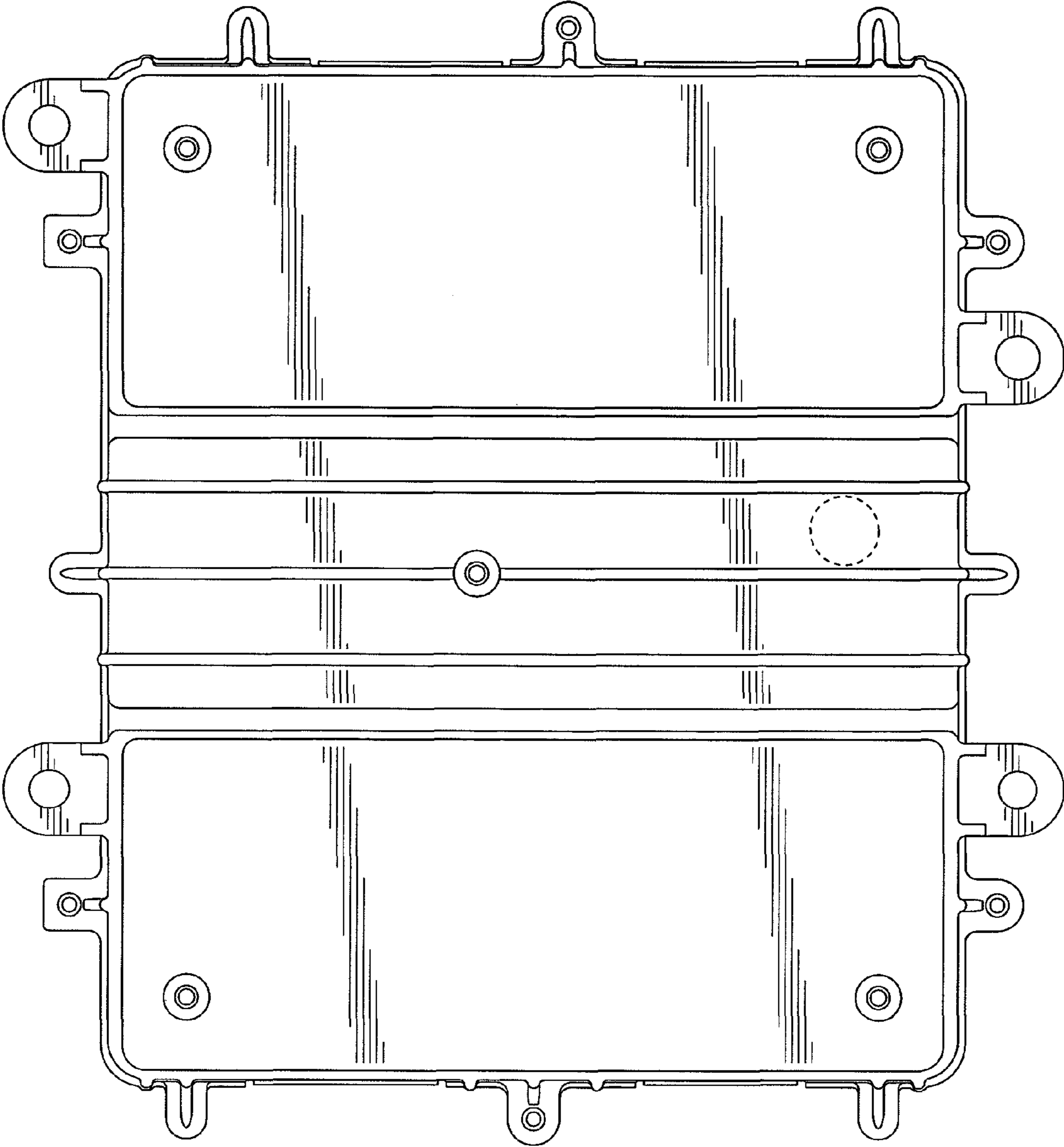

FIG. 3

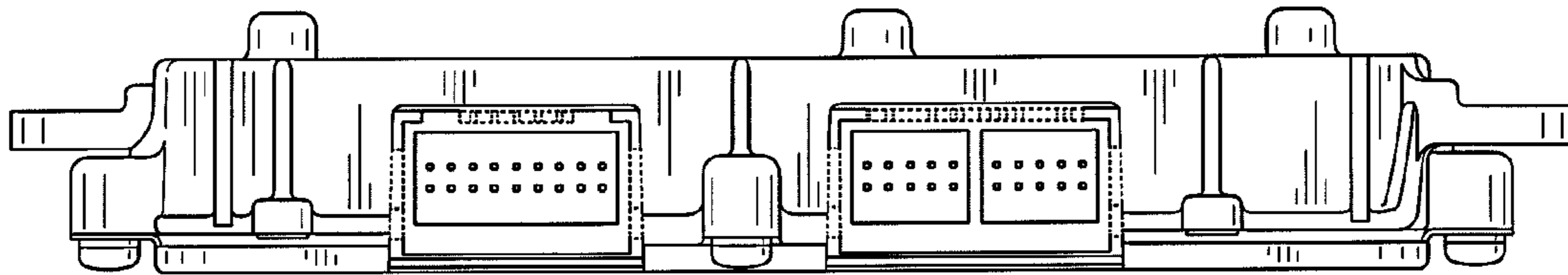

FIG. 4

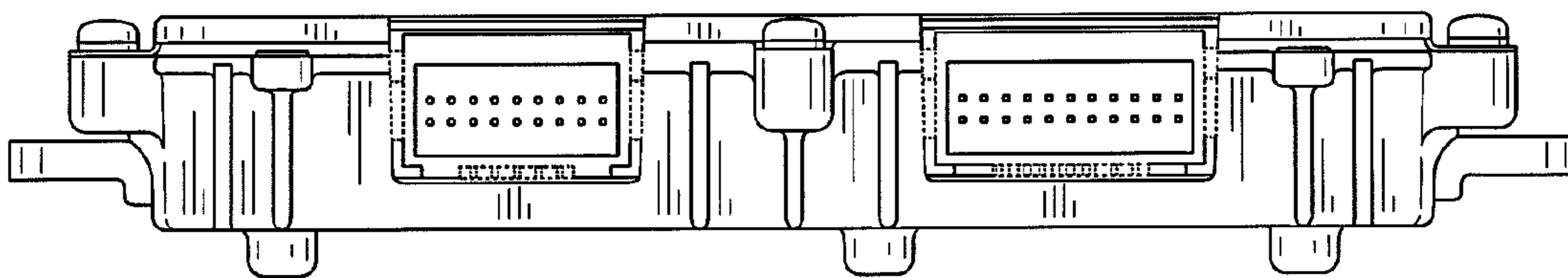

FIG. 5

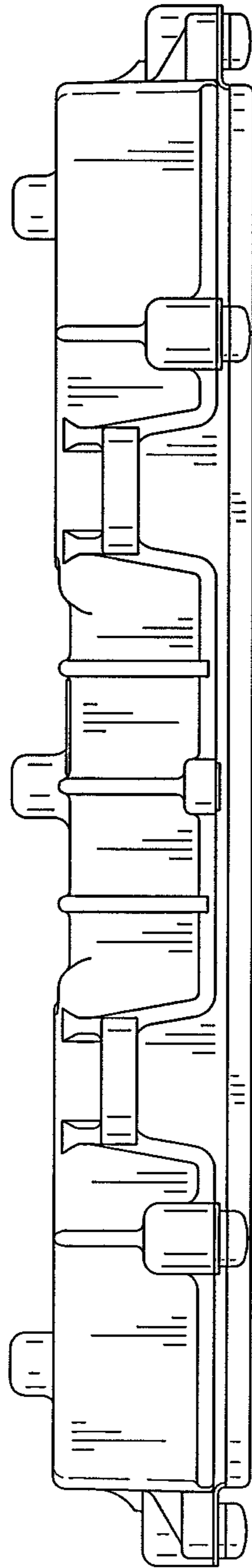

FIG. 6

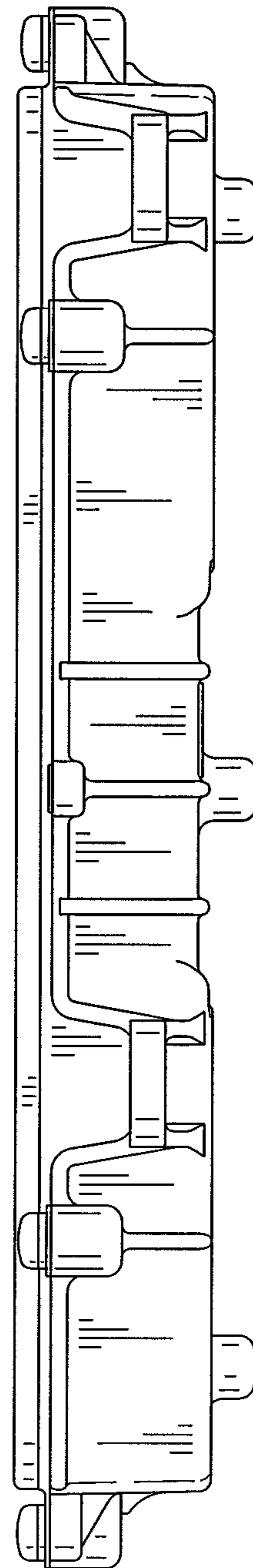

FIG. 7