



US00D683206S

(12) **United States Design Patent**
Farradas et al.

(10) **Patent No.:** **US D683,206 S**

(45) **Date of Patent:** **** May 28, 2013**

(54) **LOWER UNIT-PROPELLER COMBINATION
ANTI THEFT LOCK DEVICE**

5,884,509 A * 3/1999 LeBoeuf 70/18
5,887,460 A * 3/1999 Williams 70/18
5,904,603 A * 5/1999 Embry et al. 440/71
D484,388 S * 12/2003 Nassie et al. D8/330

(76) Inventors: **Rolando Farradas**, Miami Lakes, FL
(US); **Hector Poveda**, Southwest
Ranches, FL (US)

* cited by examiner

(**) Term: **14 Years**

Primary Examiner — Prabhakar Deshmukh

(74) *Attorney, Agent, or Firm* — Albert Bordas, P.A.

(21) Appl. No.: **29/416,991**

(22) Filed: **Mar. 29, 2012**

(51) **LOC (9) Cl.** **08-07**

(52) **U.S. Cl.**
USPC **D8/343; D8/331**

(58) **Field of Classification Search**
USPC D14/330, 331, 343, 14, 339, 346,
D14/349; 70/18, 58, 1.5, 64, 232, 234, 158,
70/57, 163–169, 175–179, DIG. 43, DIG. 57
See application file for complete search history.

(57) **CLAIM**

The ornamental design for a lower unit-propeller combination anti theft lock device, as shown and described.

DESCRIPTION

FIG. 1 is a top plan view of a lower unit-propeller combination anti theft lock device;
FIG. 2 is a front elevational view thereof;
FIG. 3 is a bottom view thereof;
FIG. 4 is a left elevational view thereof,
FIG. 5 is a rear elevational view thereof;
FIG. 6 is a right elevational view thereof; and,
FIG. 7 is an isometric view thereof, showing my design mounted onto a lower unit and propeller assembly.
The broken lines are for environmental purposes only and form no part of the claimed design.
The claimed lower unit-propeller combination anti theft lock device is mounted onto a boat engine to prevent removal of a lower unit and propeller assembly.

(56) **References Cited**

U.S. PATENT DOCUMENTS

3,759,076 A * 9/1973 Reese 70/232
3,981,165 A * 9/1976 Wersinger 70/232
4,538,962 A * 9/1985 McCain 416/146 R
D298,911 S * 12/1988 Burke, Sr. D8/330
5,184,488 A * 2/1993 Sandlin 70/14
D358,076 S * 5/1995 Woller et al. D8/331
5,417,093 A * 5/1995 Heiberg 70/232
5,613,386 A * 3/1997 Mire, Sr. 70/232

1 Claim, 3 Drawing Sheets

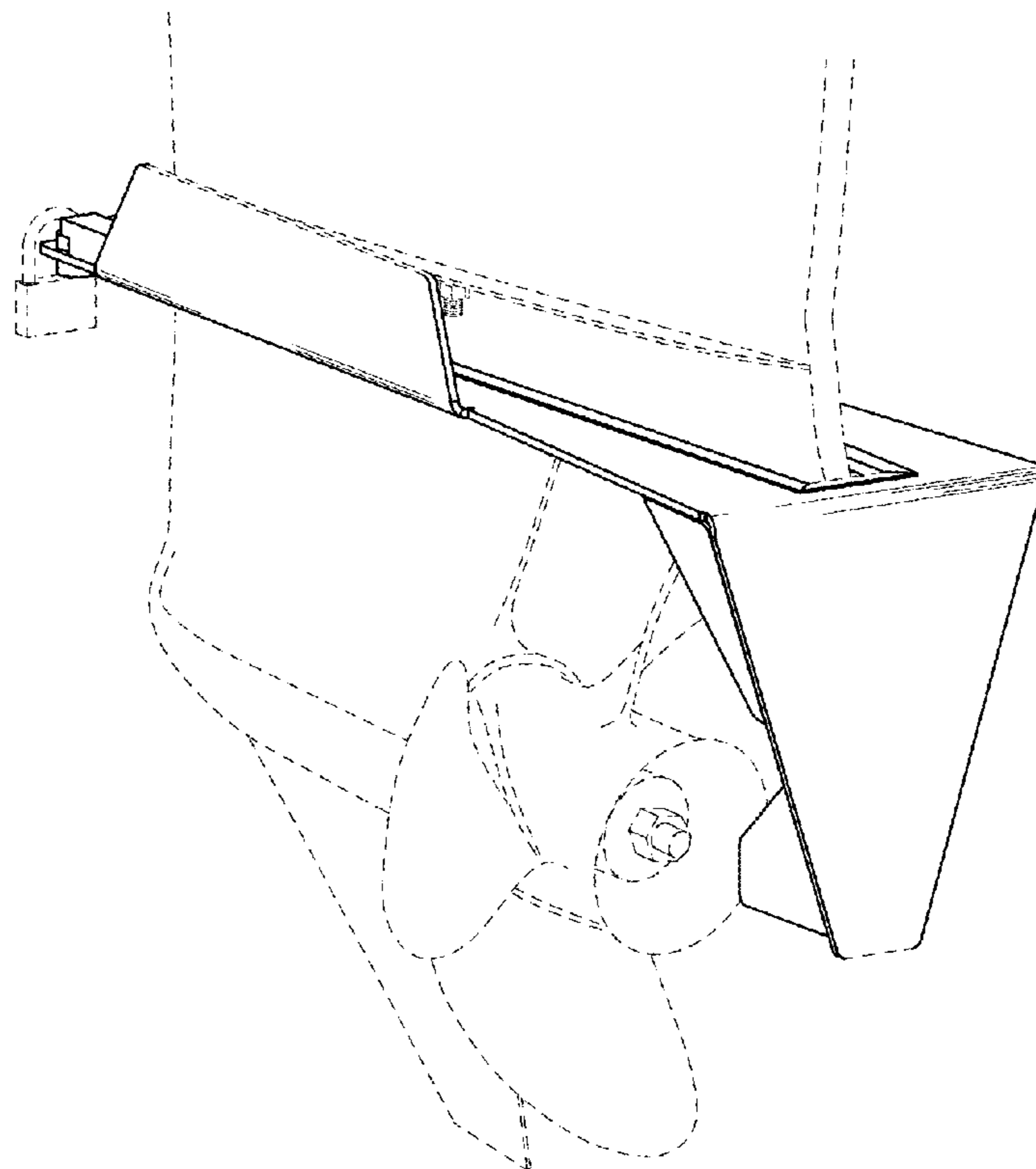

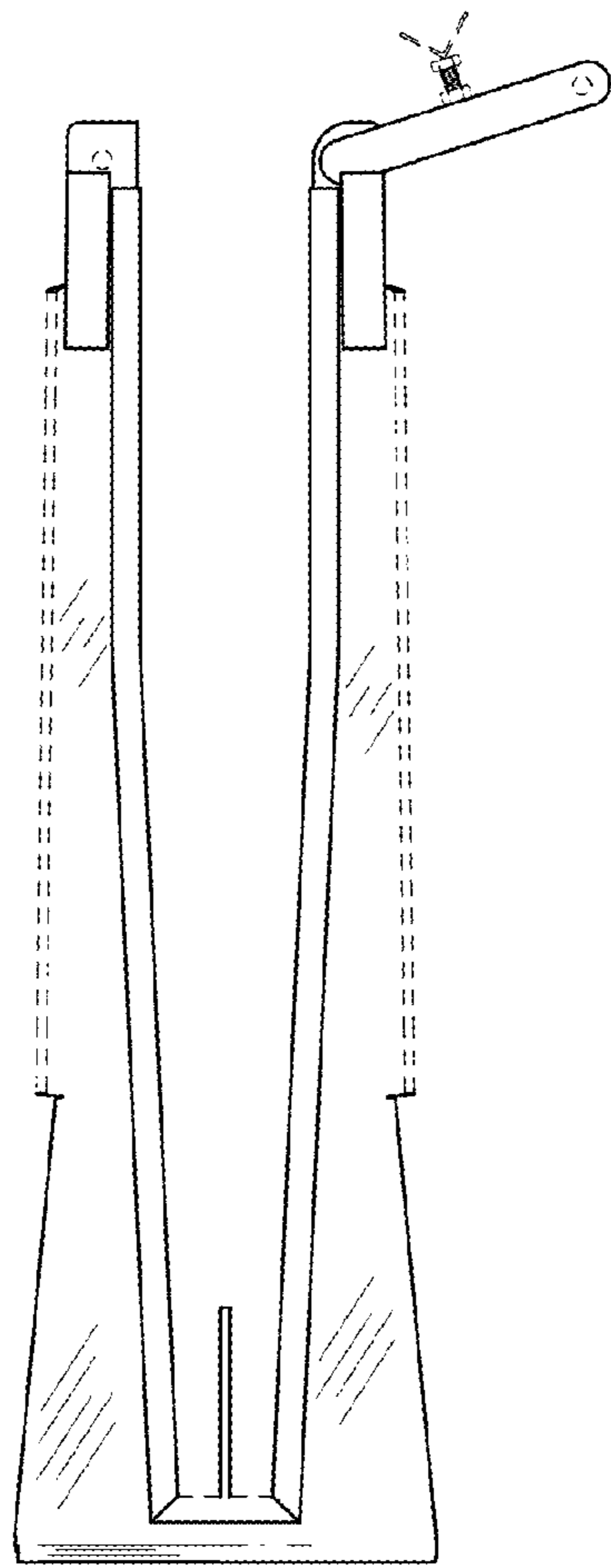

Fig. 1

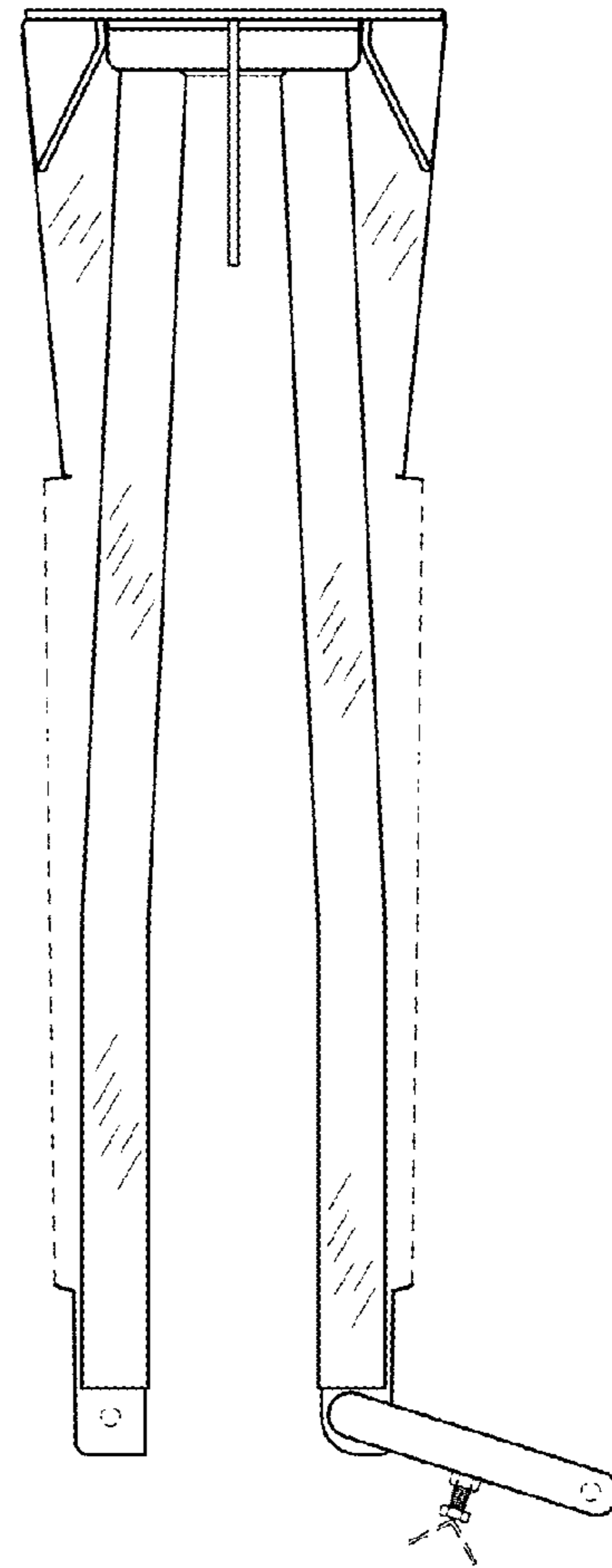

Fig. 3

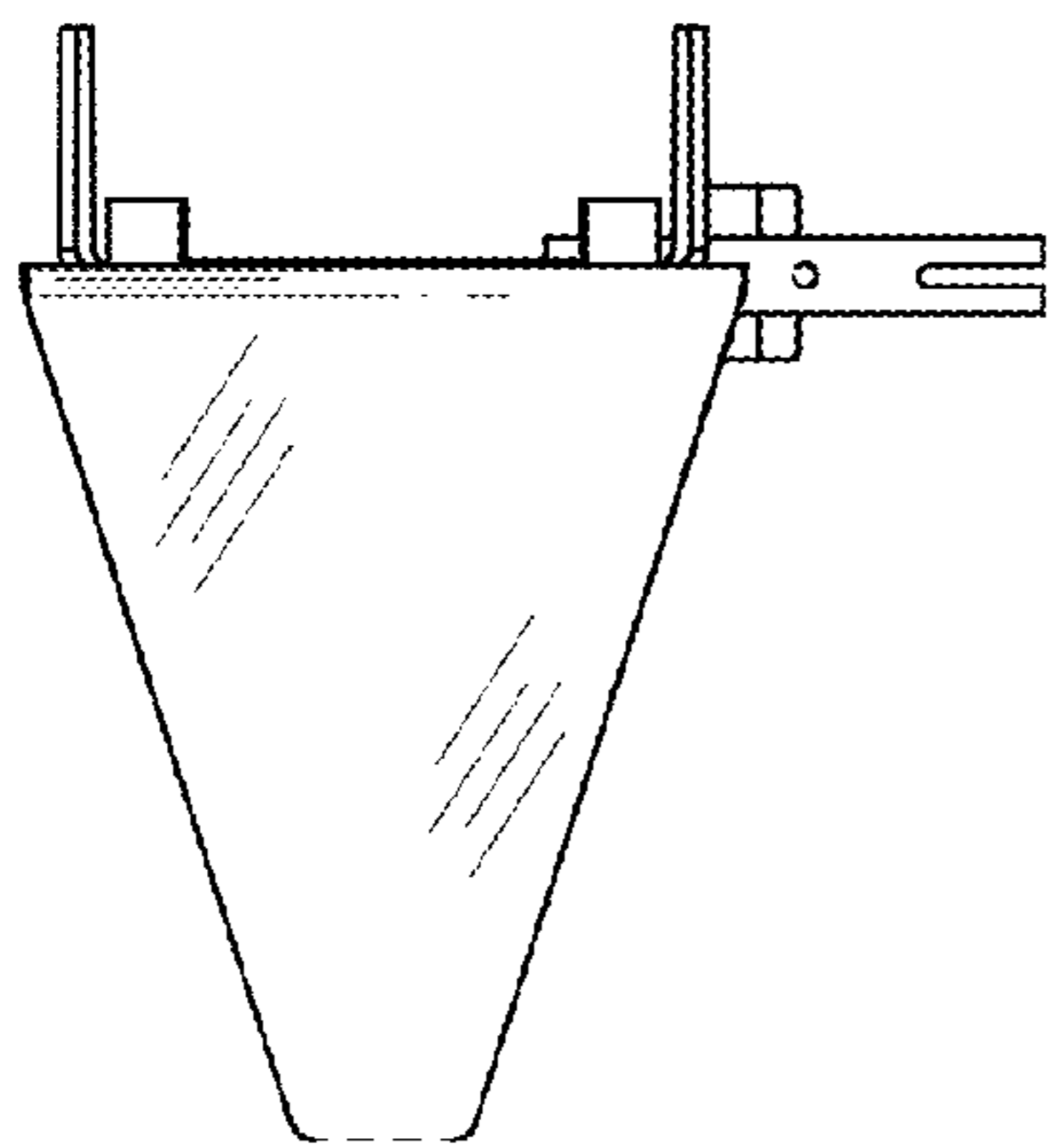

Fig. 2

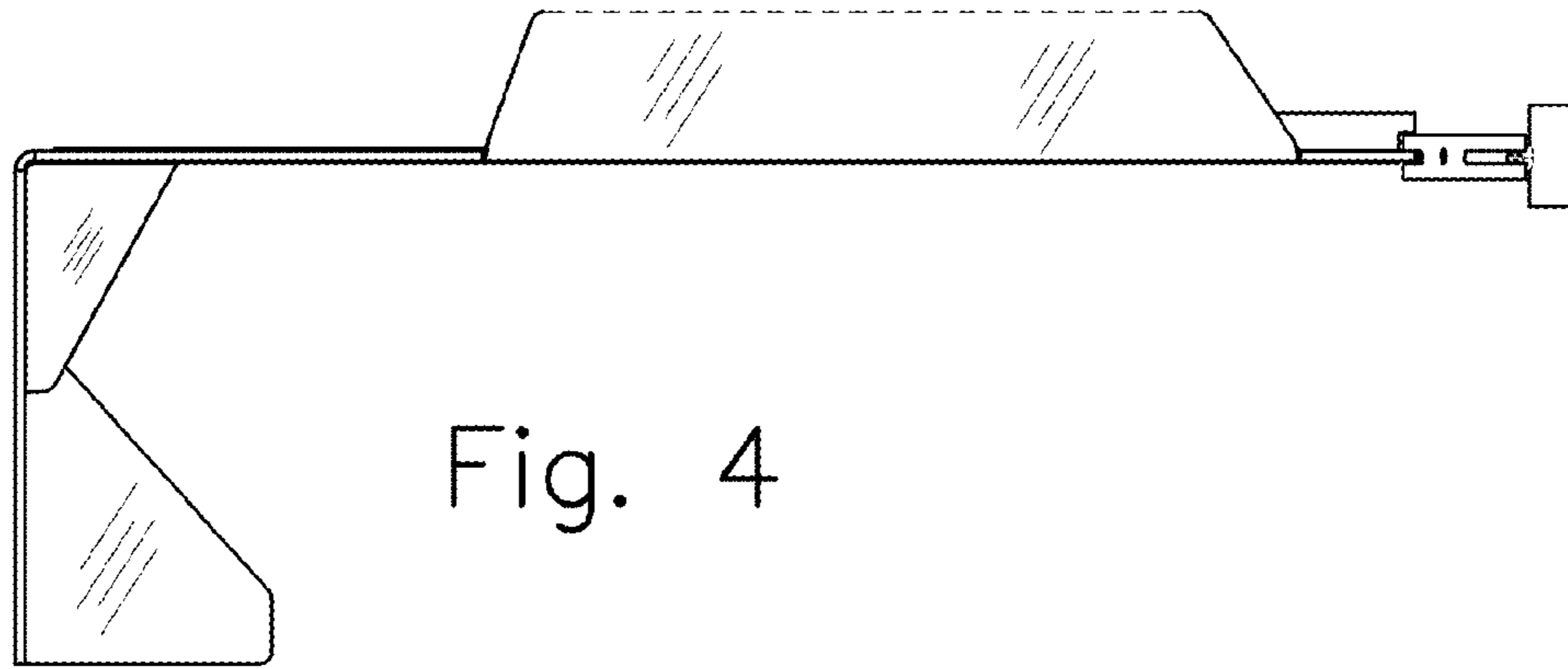

Fig. 4

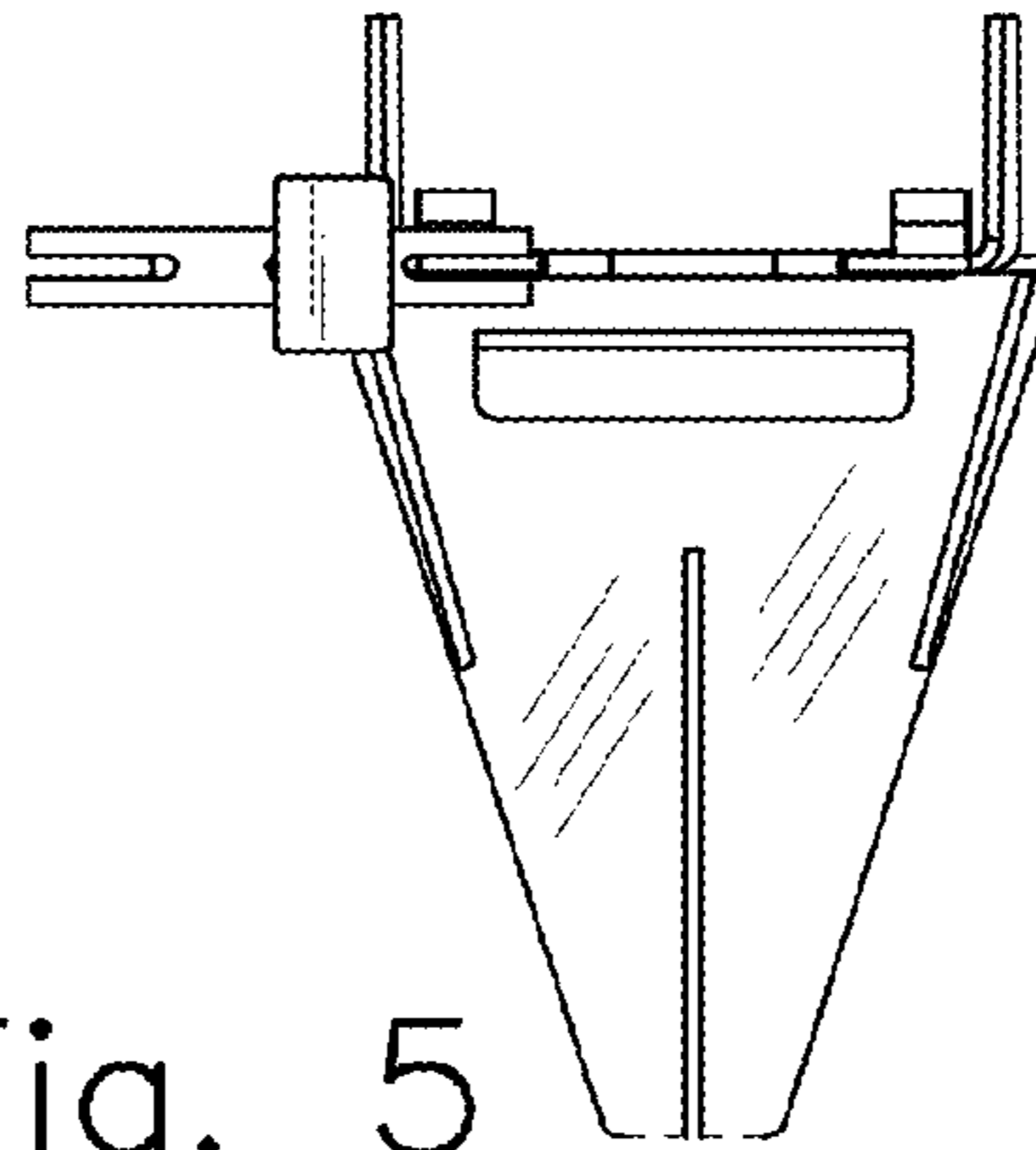

Fig. 5

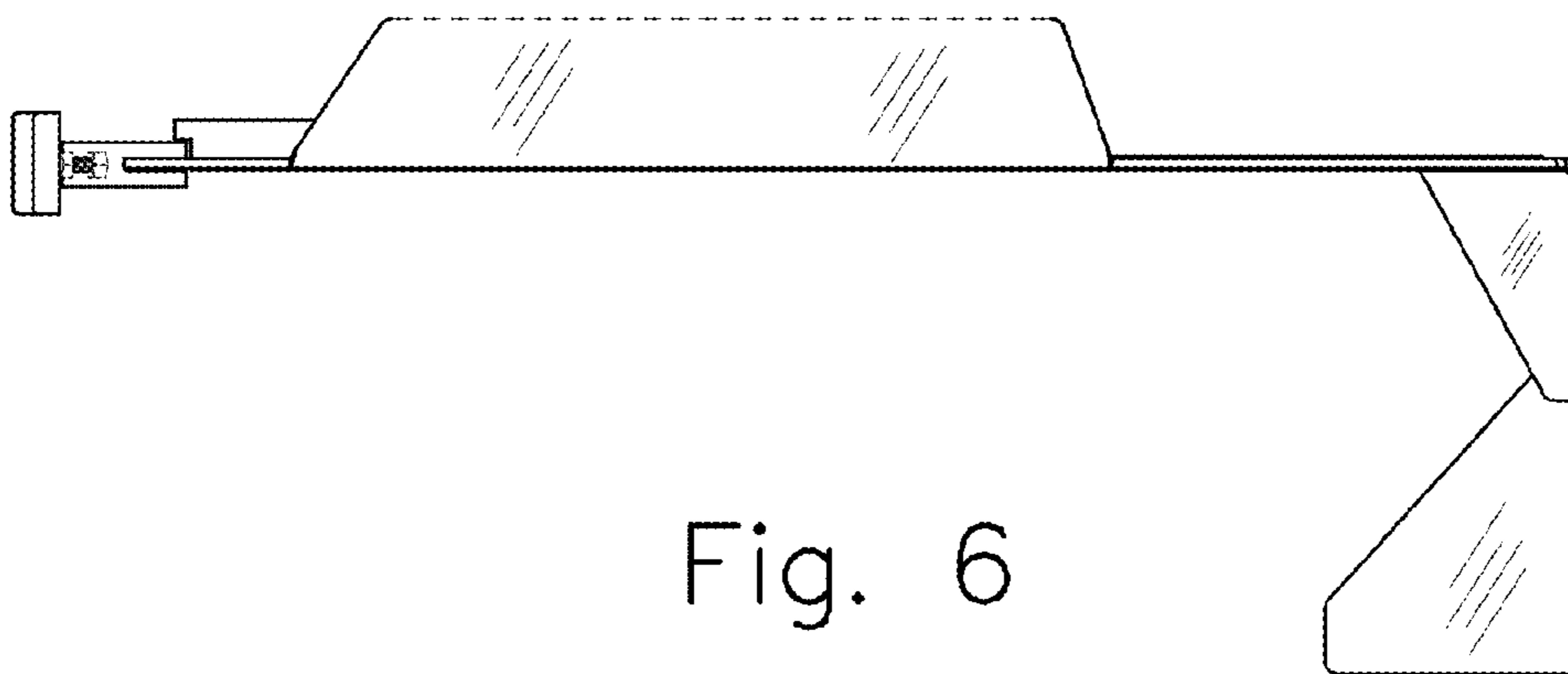

Fig. 6

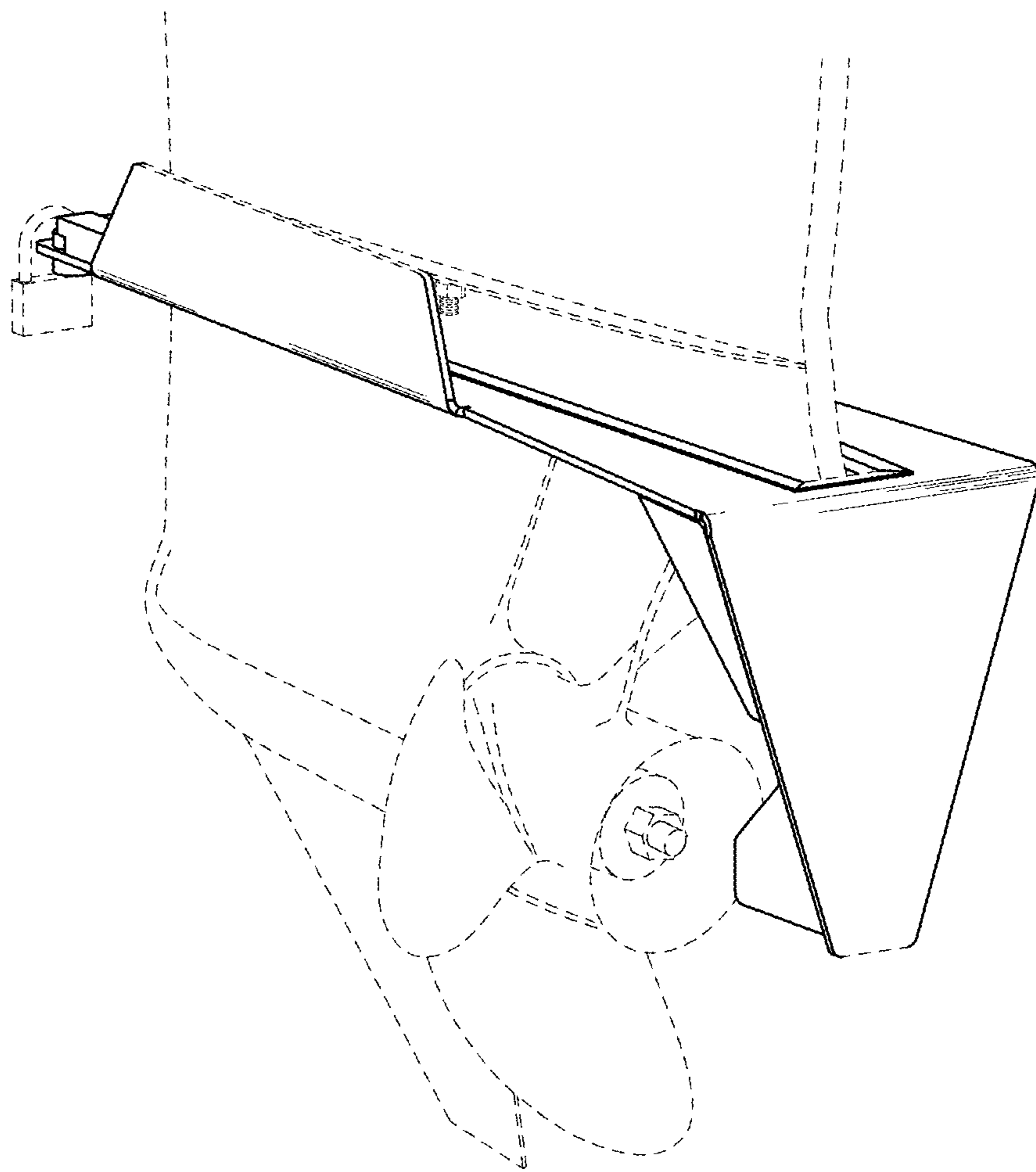

Fig. 7