

US00D682884S

(12) **United States Design Patent**
Aruga et al.

(10) **Patent No.:** **US D682,884 S**

(45) **Date of Patent:** **** May 21, 2013**

(54) **COVER FOR INTERNAL COMBUSTION ENGINE**

(75) Inventors: **Hiroyasu Aruga**, Tokyo (JP); **Kazuyuki Uenoyama**, Tokyo (JP); **Toshiya Hashimoto**, Tokyo (JP)

D638,856 S * 5/2011 Koizumi et al. D15/5
D643,854 S * 8/2011 Sugiyama et al. D15/5
D644,664 S * 9/2011 Sugiyama et al. D15/1
D646,299 S * 10/2011 Aruga et al. D15/1
D667,024 S * 9/2012 Taniguchi et al. D15/1

(73) Assignee: **Mitsubishi Heavy Industries, Ltd.**, Tokyo (JP)

(**) Term: **14 Years**

(21) Appl. No.: **29/429,011**

(22) Filed: **Aug. 6, 2012**

(30) **Foreign Application Priority Data**

Feb. 7, 2012 (JP) 2012-002482

(51) **LOC (9) Cl.** **15-01**

(52) **U.S. Cl.**
USPC **D15/5**

(58) **Field of Classification Search** D15/1,
D15/2, 3, 5, 6, 14, 17, 149; 123/22, 41.34,
123/51 A, 606 R, 52.1, 50 A, 50 B, 54.1,
123/54.2, 54.4, 54.5, 65 R, 195 R, 195 HC,
123/657, 311

See application file for complete search history.

(56) **References Cited**

U.S. PATENT DOCUMENTS

5,934,240 A * 8/1999 Yokocho et al. 123/195 C
D416,265 S * 11/1999 Kato et al. D15/1
D503,410 S * 3/2005 Kato D15/1
D599,822 S * 9/2009 Okuda D15/1
D623,197 S * 9/2010 Hotta et al. D15/1
D637,622 S * 5/2011 Aruga et al. D15/5

OTHER PUBLICATIONS

Certificate of Registration issued on Oct. 8, 2012 from the OHIM for 001338370-0001.

Certificate of Registration issued on Oct. 8, 2012 from the OHIM for 001338370-0002.

Chinese Notification of Grant Patent Right issued on Oct. 9, 2012 and English translation.

* cited by examiner

Primary Examiner — T. Chase Nelson

Assistant Examiner — Ania Aman

(74) *Attorney, Agent, or Firm* — Birch, Stewart, Kolasch & Birch, LLP

(57) **CLAIM**

The ornamental design for a cover for internal combustion engine, as shown and described.

DESCRIPTION

FIG. 1 is a front perspective view of a cover for internal combustion engine in accordance with the present design; FIG. 2 is a rear perspective view thereof; FIG. 3 is a front view thereof; FIG. 4 is a rear view thereof; FIG. 5 is a left side view thereof; FIG. 6 is a right side view thereof; FIG. 7 is a top plan view thereof; and, FIG. 8 is a bottom plan view thereof.

The portion of the cover for internal combustion engine shown in broken lines form no part of the claimed design.

1 Claim, 8 Drawing Sheets

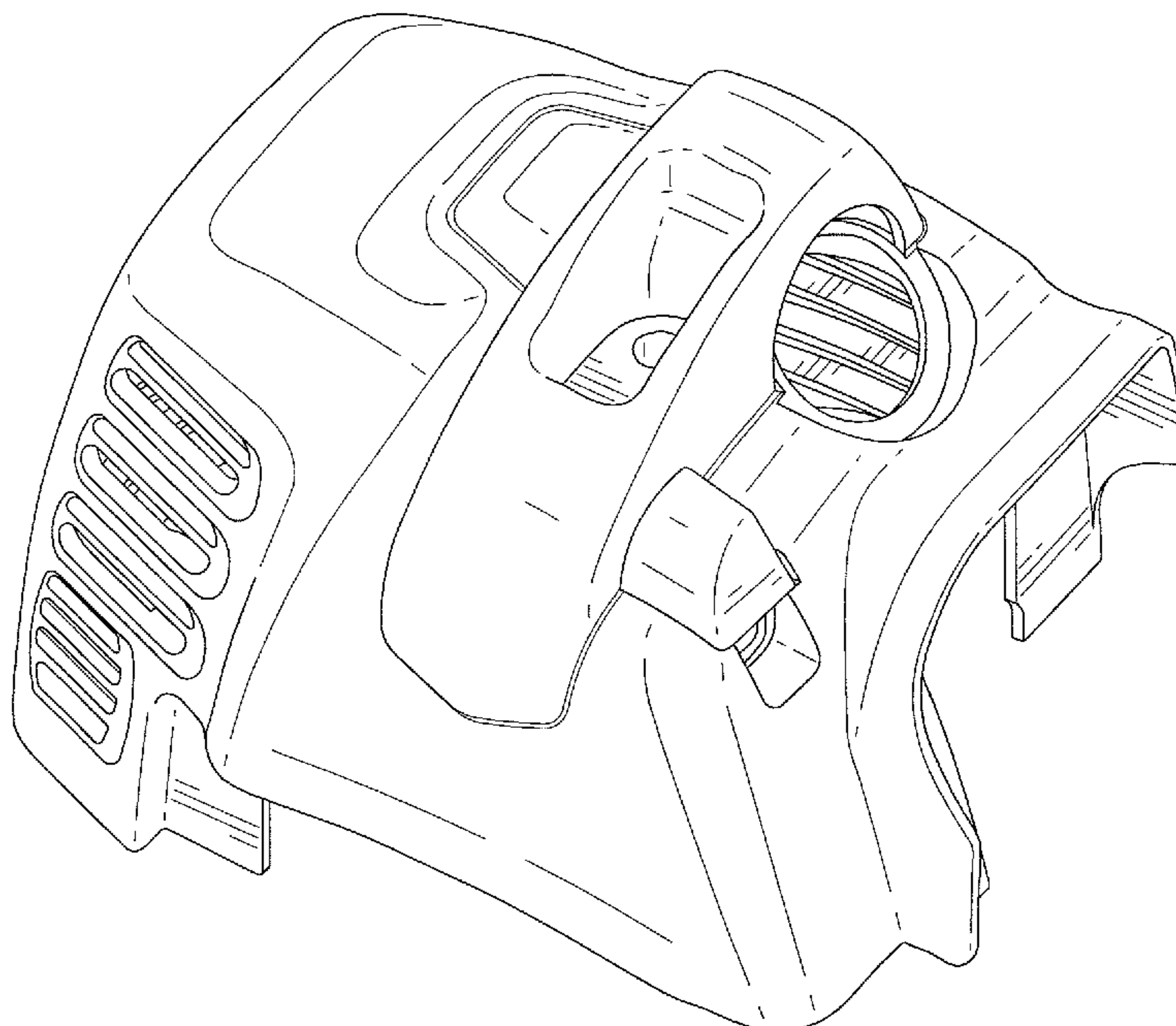

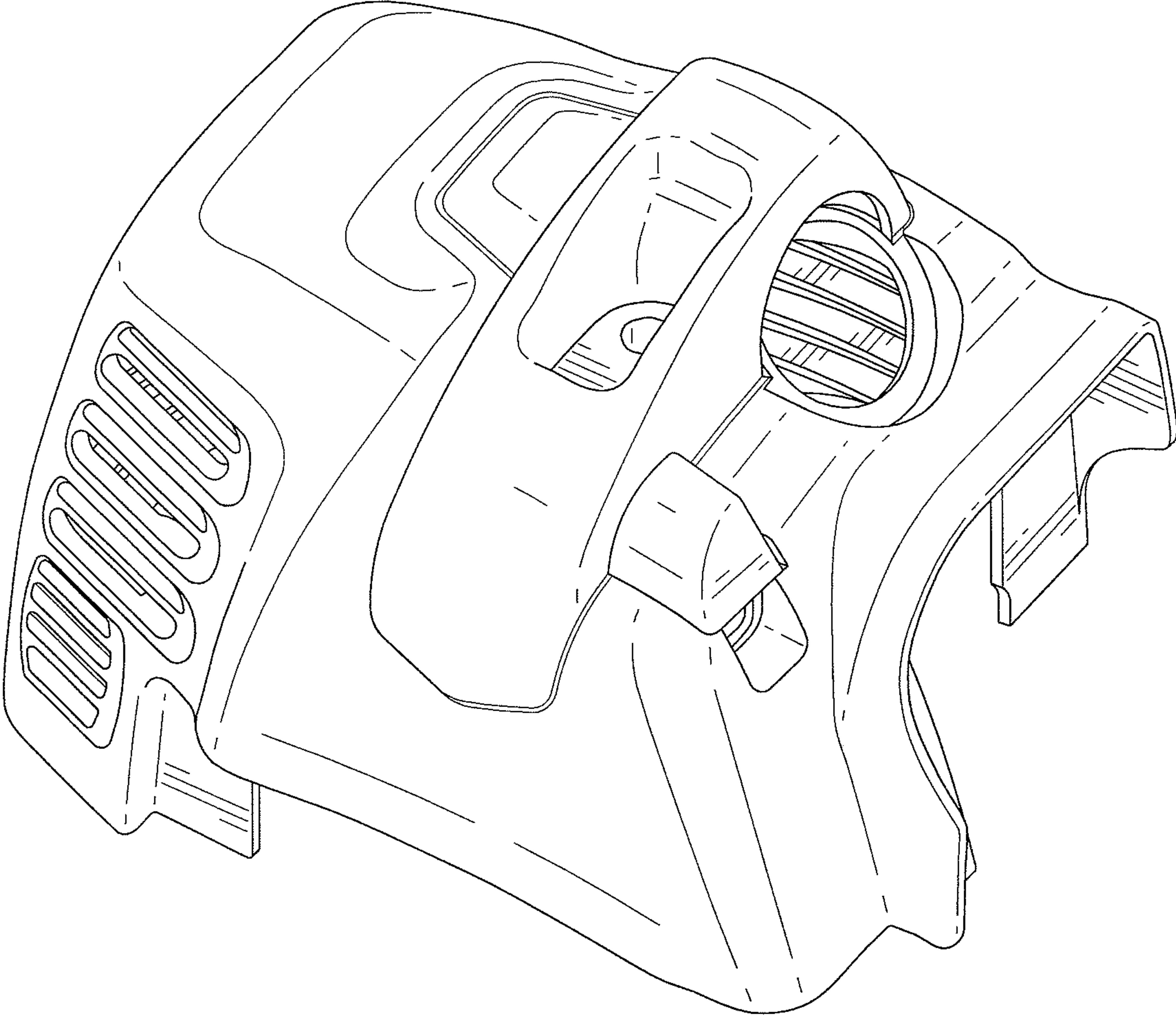

FIG.1

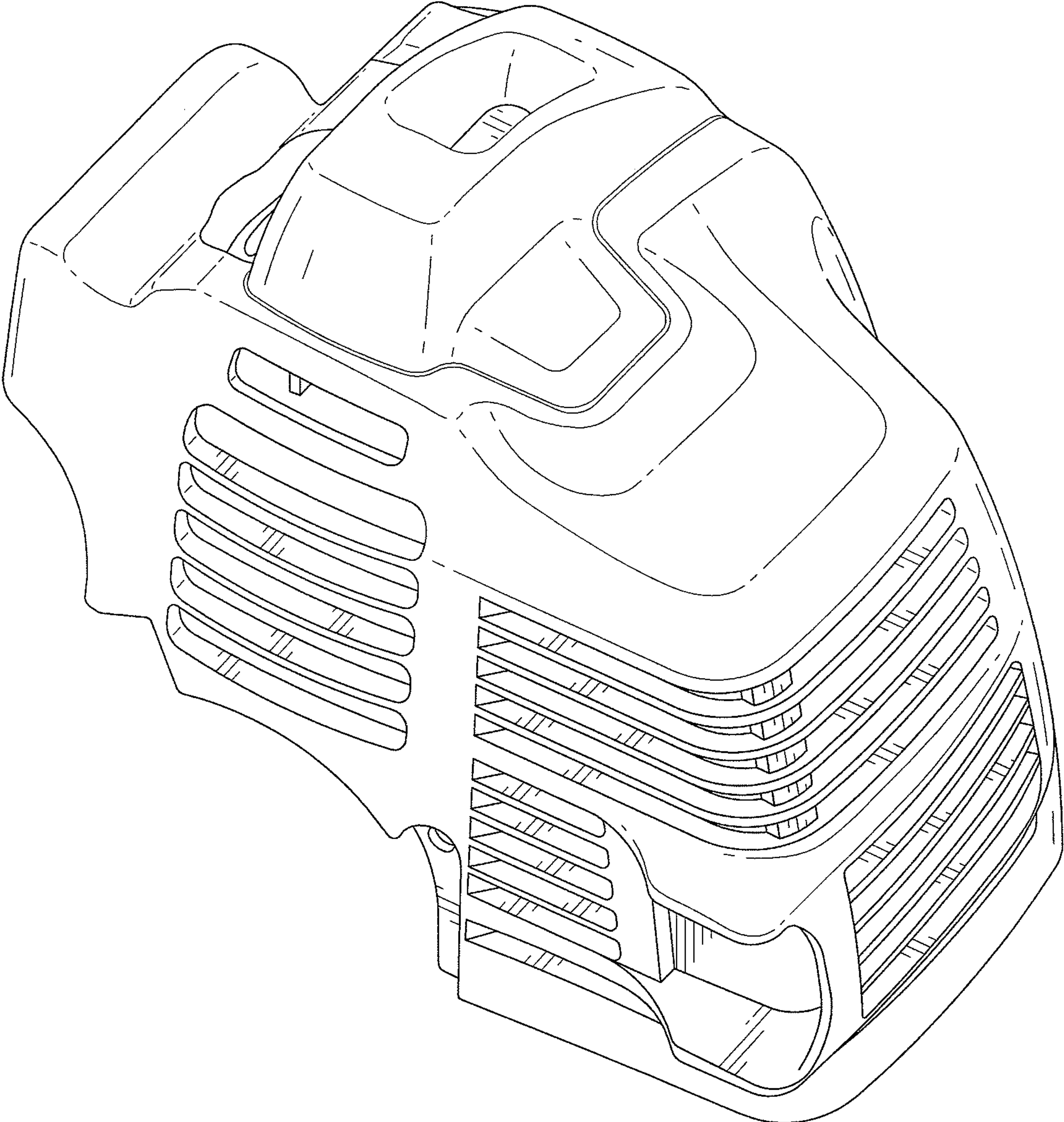

FIG.2

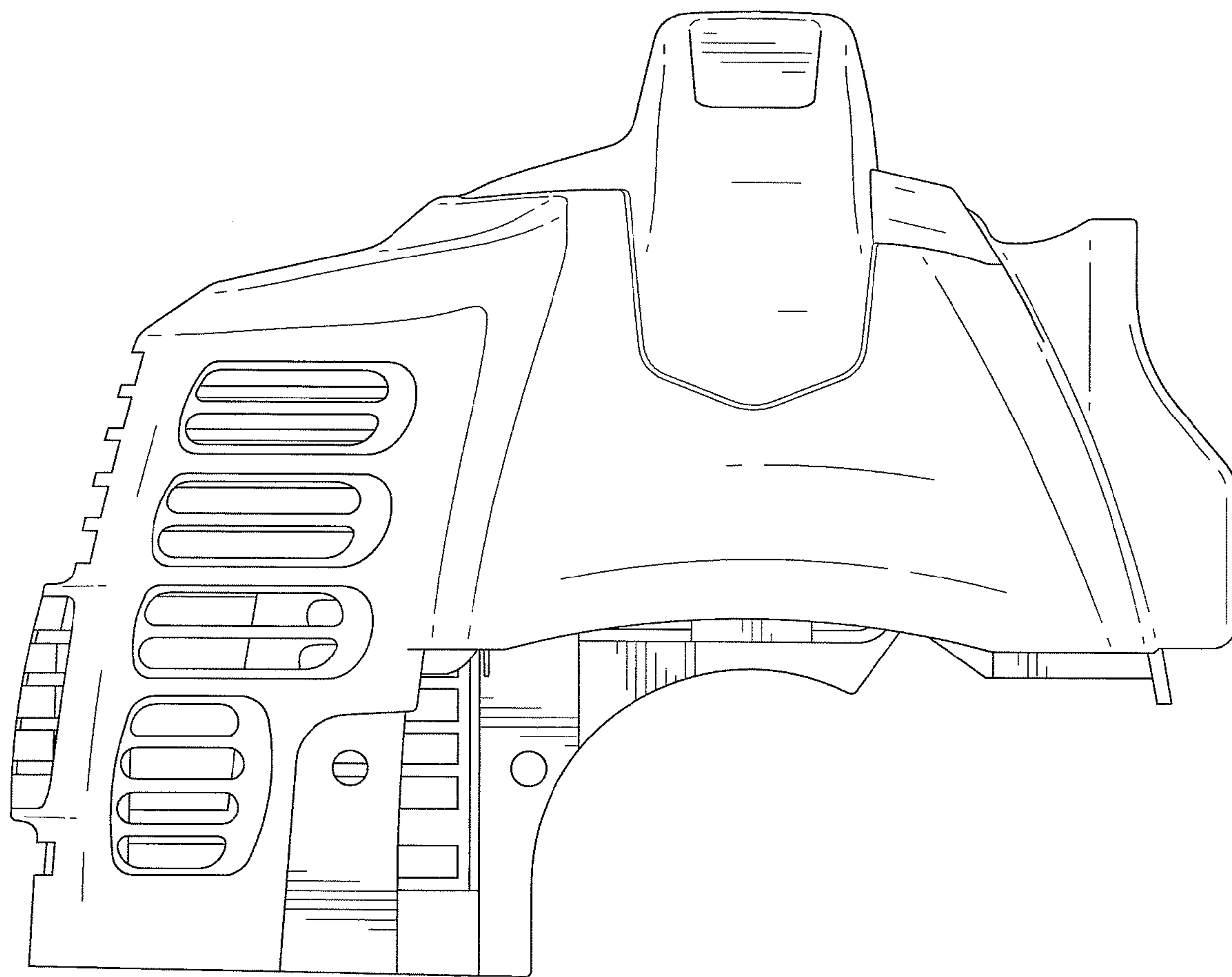

FIG.3

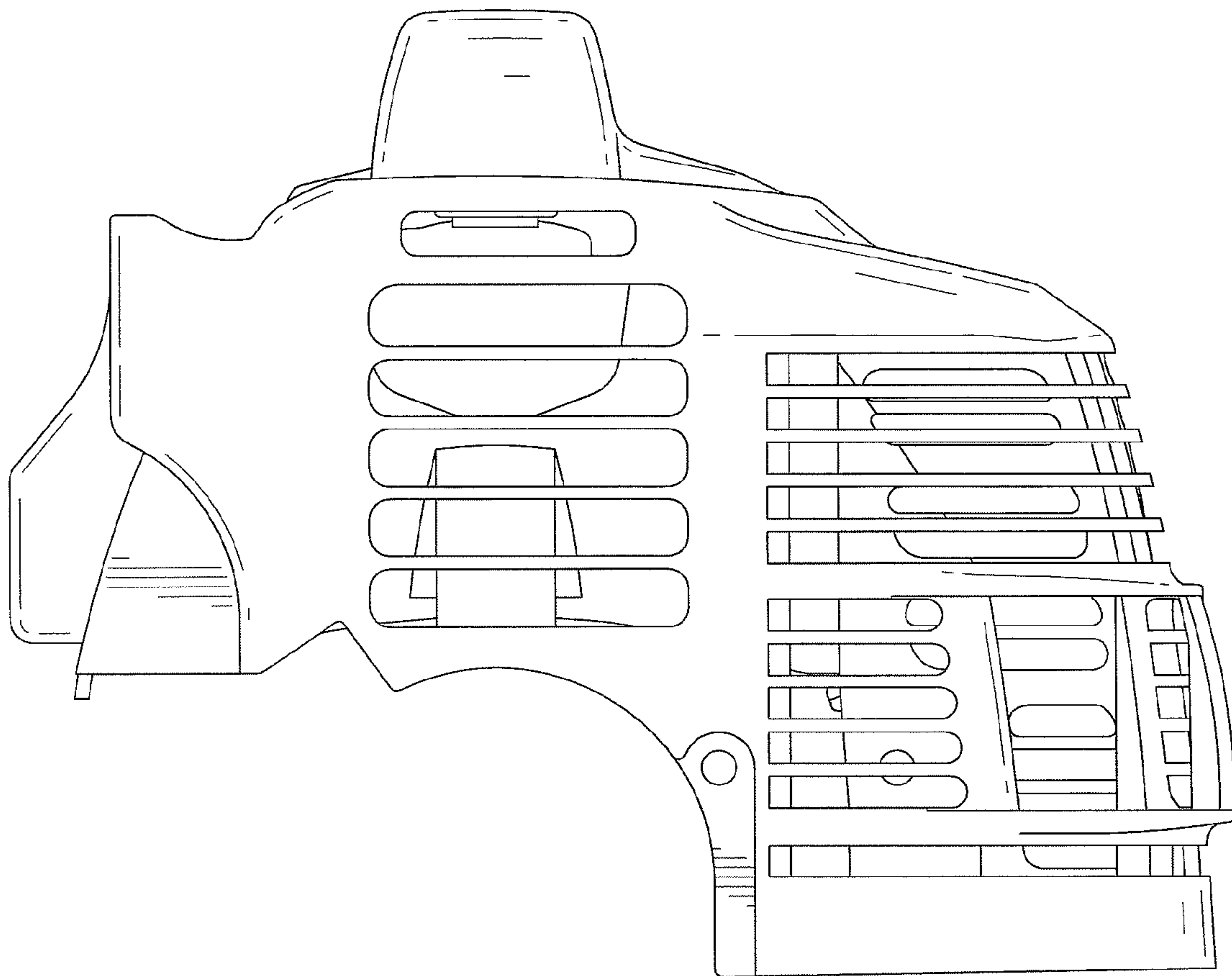

FIG.4

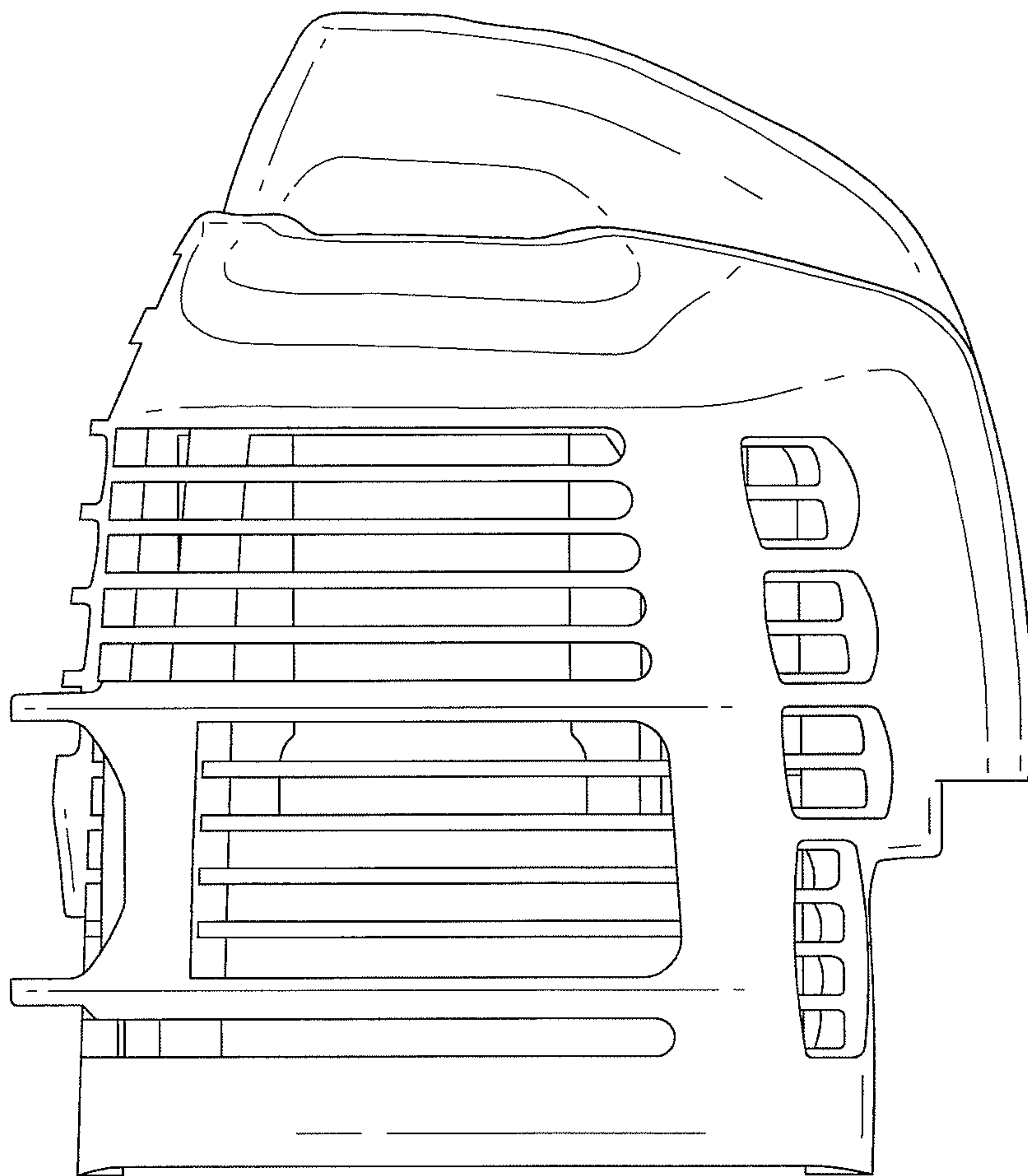

FIG.5

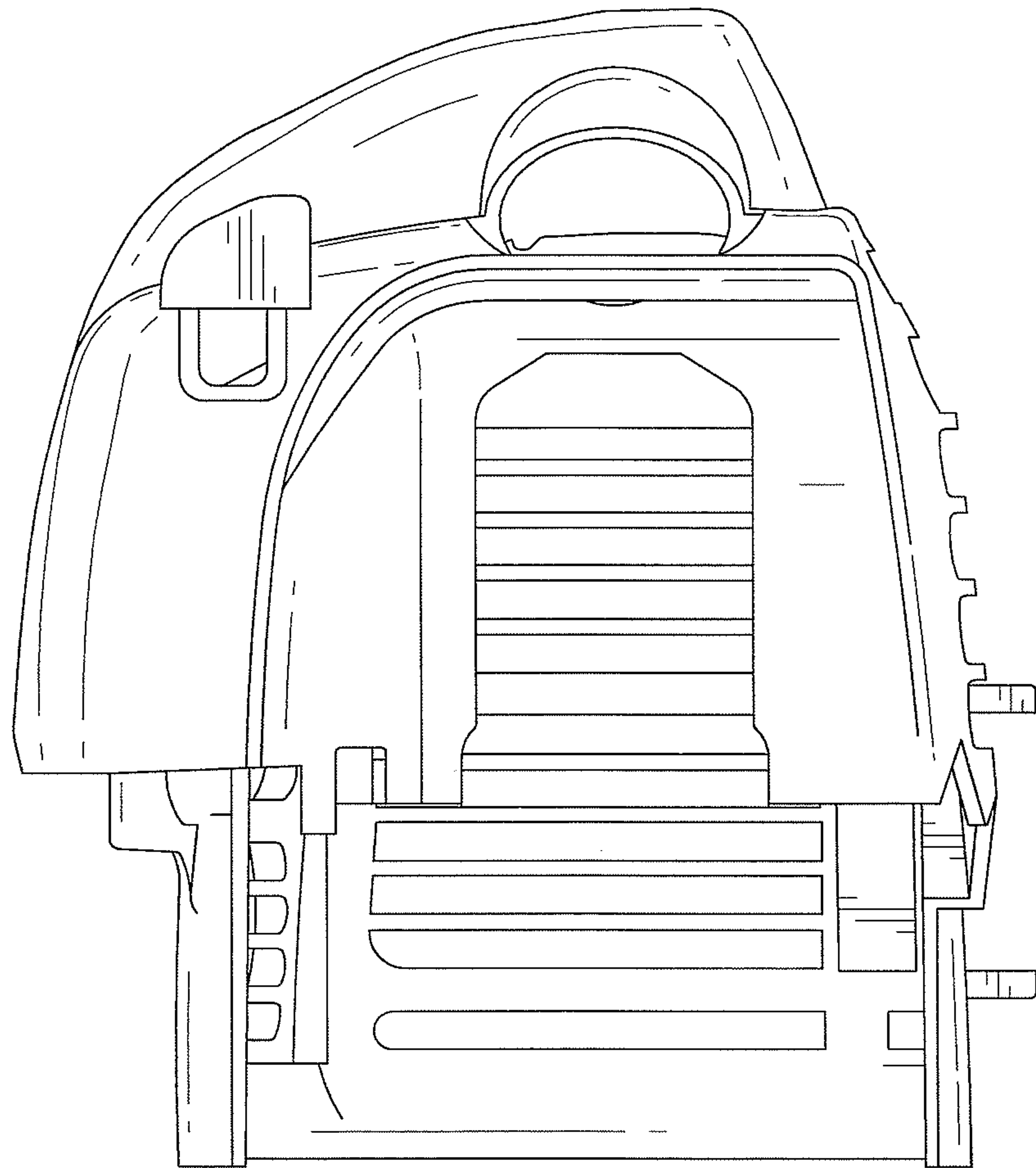

FIG.6

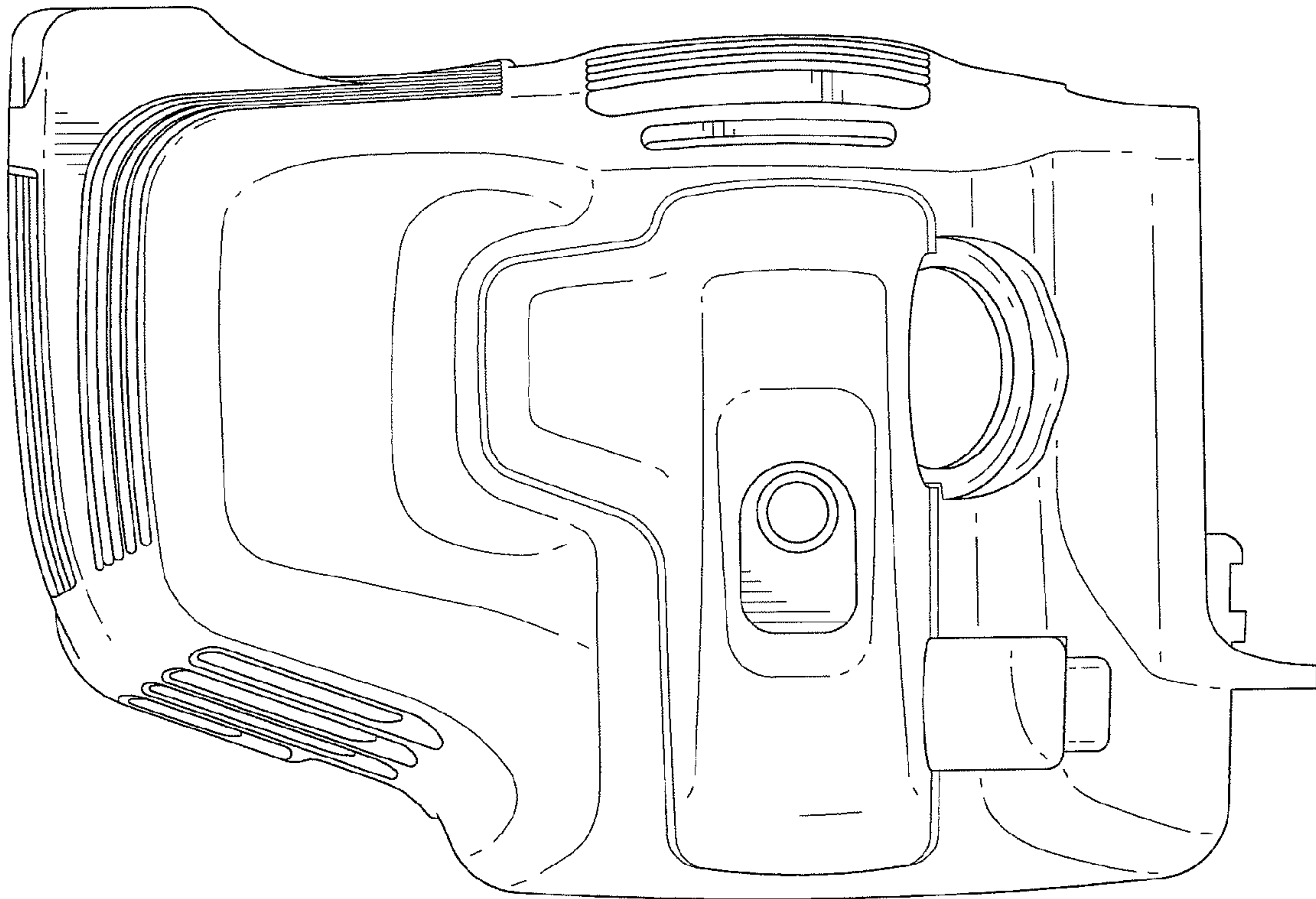

FIG. 7

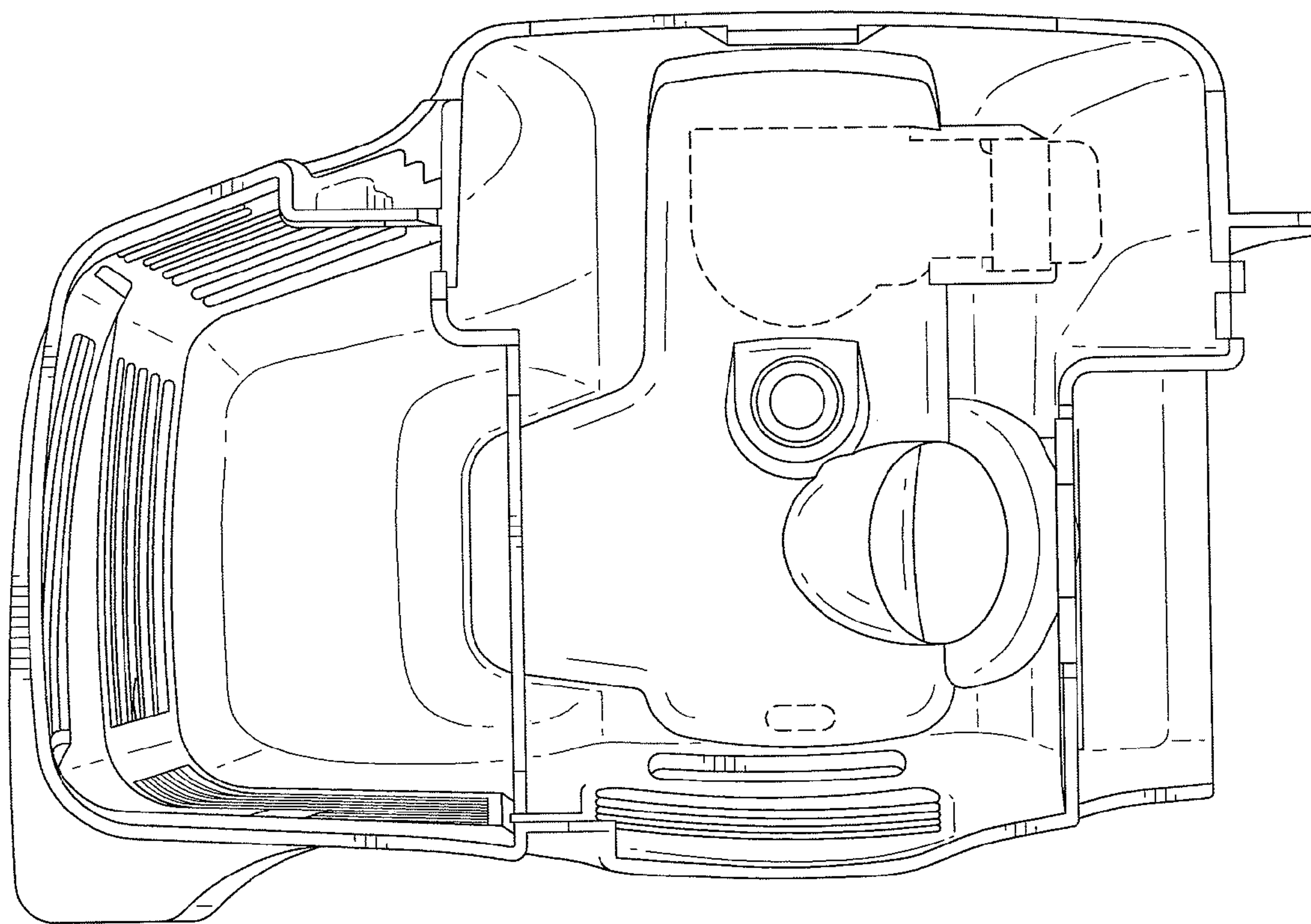

FIG.8