



US00D682718S

(12) **United States Design Patent**
Azuma

(10) **Patent No.:** **US D682,718 S**

(45) **Date of Patent:** **** May 21, 2013**

(54) **BURNED CALORIES METER**

(75) Inventor: **Shigeharu Azuma**, Tokyo (JP)

(73) Assignee: **Tanita Corporation**, Tokyo (JP)

(**) Term: **14 Years**

(21) Appl. No.: **29/412,362**

(22) Filed: **Feb. 2, 2012**

(30) **Foreign Application Priority Data**

Sep. 14, 2011 (JP) 2011-20893

(51) **LOC (9) Cl.** **10-04**

(52) **U.S. Cl.**
USPC **D10/70; D10/78; D10/81; D10/97**

(58) **Field of Classification Search** D10/70,
D10/78, 81, 97; 235/105; 377/5, 24.2, 26; 73/514.33,
73/514.34, 510, 513, 527, 530; 702/155,
702/160, 176, 78, 79, 82, 91, 92-95, 104,
702/116, 141, 150, 151, 154, 127, 131, 182,
702/183, 189; 324/522; 345/165, 156, 905; 600/437,
600/443, 453, 459, 465, 479, 500, 502, 595,
600/485, 481, 483

See application file for complete search history.

(56) **References Cited**

U.S. PATENT DOCUMENTS

D584,974 S * 1/2009 Fukuda et al. D10/70
D597,425 S * 8/2009 Au Yeung D10/70
D635,873 S * 4/2011 Ogihara et al. D10/70
D651,105 S * 12/2011 Teo et al. D10/78

D665,679 S * 8/2012 Shigeno et al. D10/70
D669,375 S * 10/2012 Kao et al. D10/81
D669,800 S * 10/2012 Takayama et al. D10/70

* cited by examiner

Primary Examiner — Antoine D Davis

(74) *Attorney, Agent, or Firm* — Holtz, Holtz, Goodman & Chick, P.C.

(57) **CLAIM**

The ornamental design for a burned calories meter, as shown and described.

DESCRIPTION

FIG. 1 is a front, right side, bottom perspective view of a burned calories meter showing my new design;

FIG. 2 is a front elevational view thereof;

FIG. 3 is a rear elevational view thereof;

FIG. 4 is a left side view thereof;

FIG. 5 is a right side view thereof;

FIG. 6 is a top plan view thereof;

FIG. 7 is a bottom plan view thereof;

FIG. 8 is a reference perspective view thereof showing a state in which a cap part is detached;

FIG. 9 is a reference front elevational view thereof showing a state in which a cap part is detached;

FIG. 10 is a reference rear elevational view thereof showing a state in which a cap part is detached;

FIG. 11 is a reference top plan view thereof showing a state in which a cap part is detached; and,

FIG. 12 is a reference front elevational view thereof, showing a state in which this article is electrified.

The portions in broken lines are shown for illustrative purposes only and form no part of the claimed design.

1 Claim, 7 Drawing Sheets

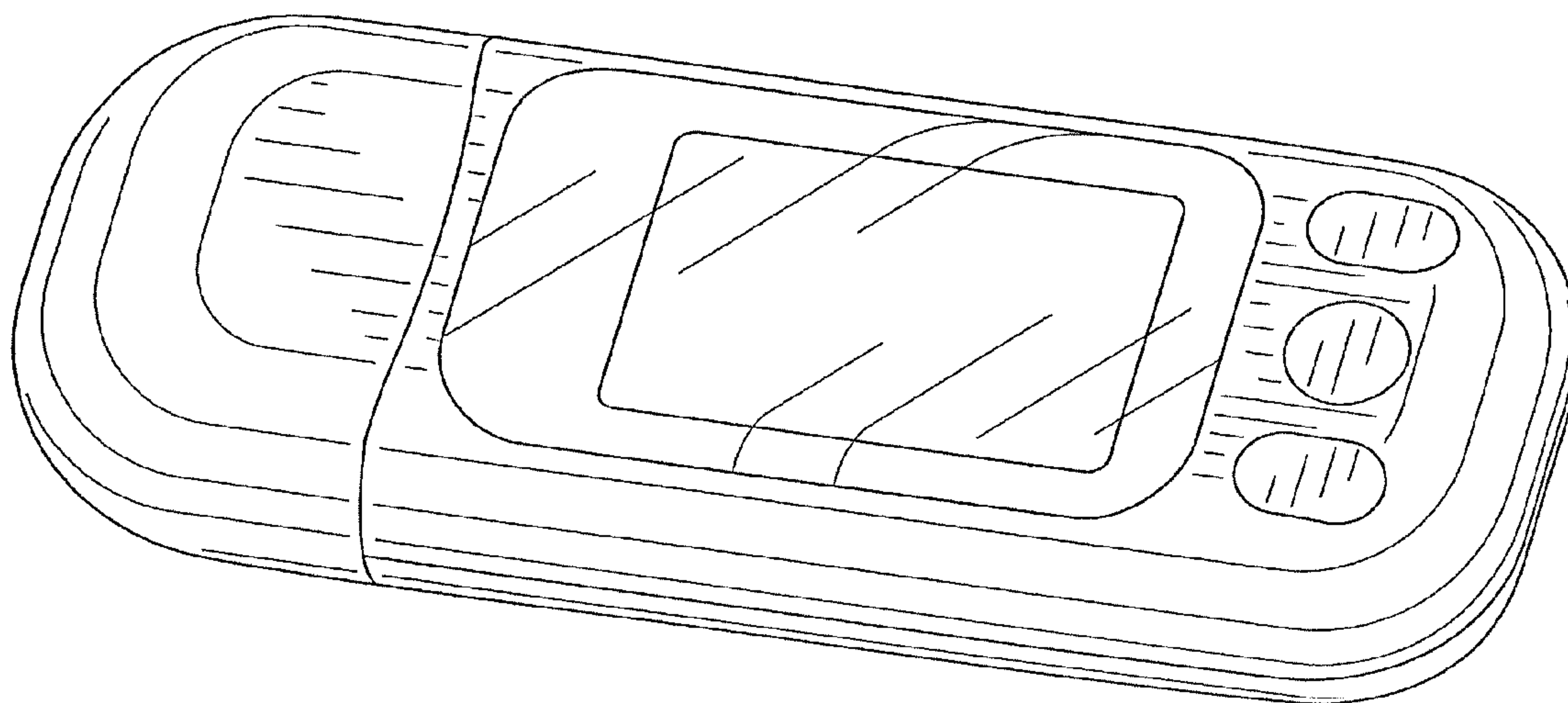

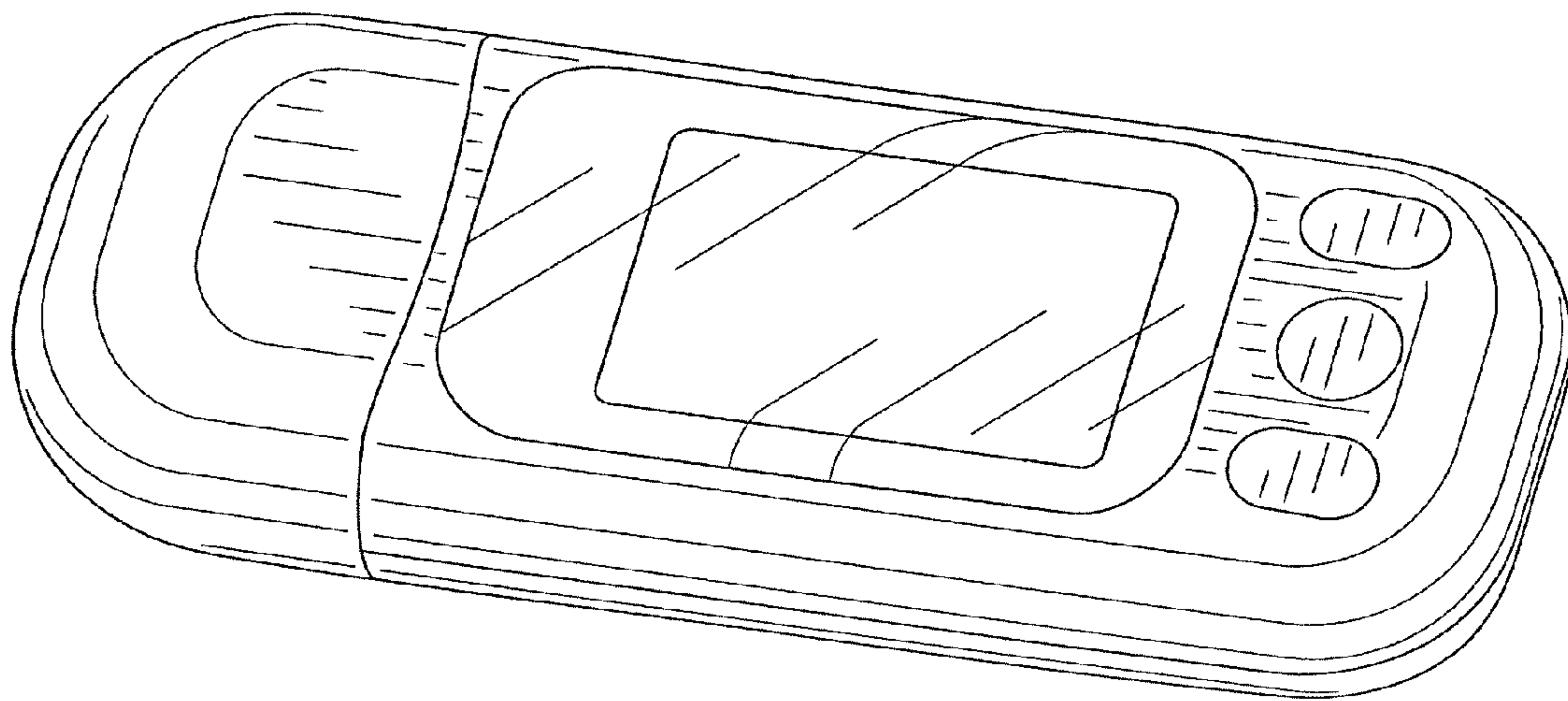

FIG. 1

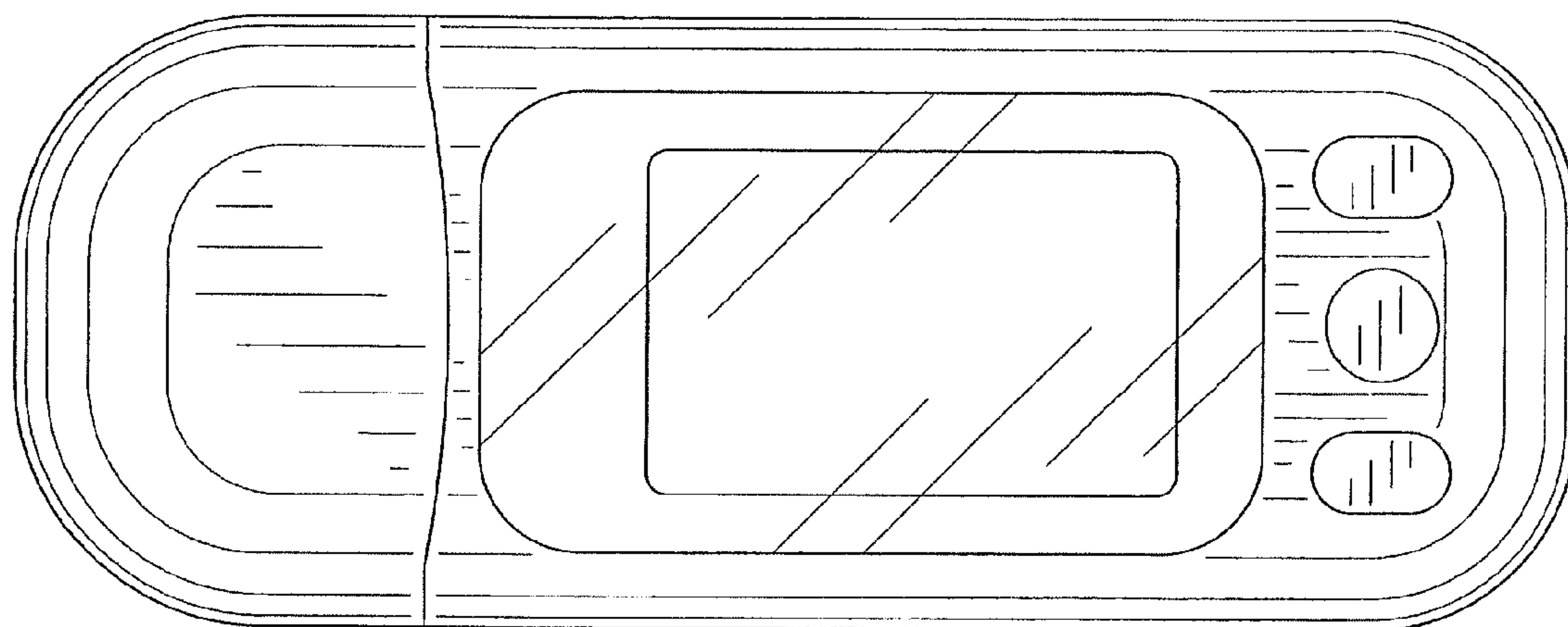

FIG. 2

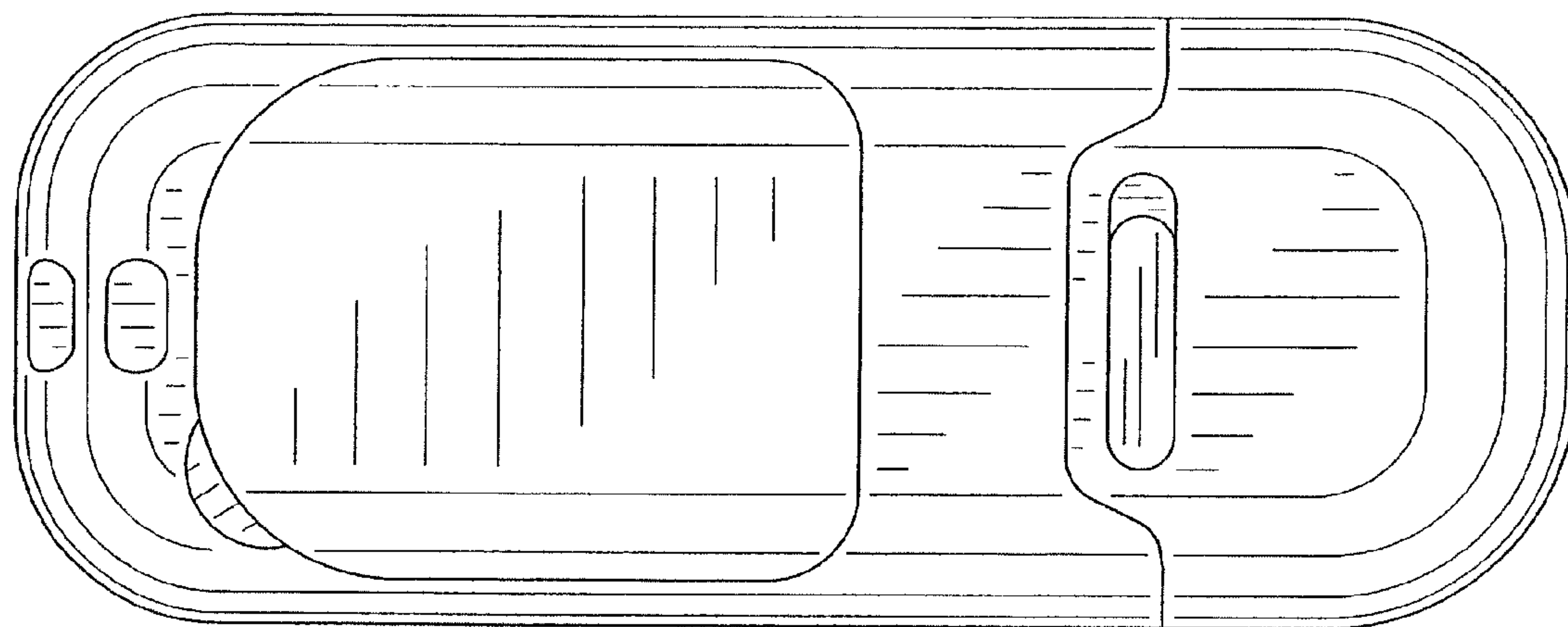

FIG. 3

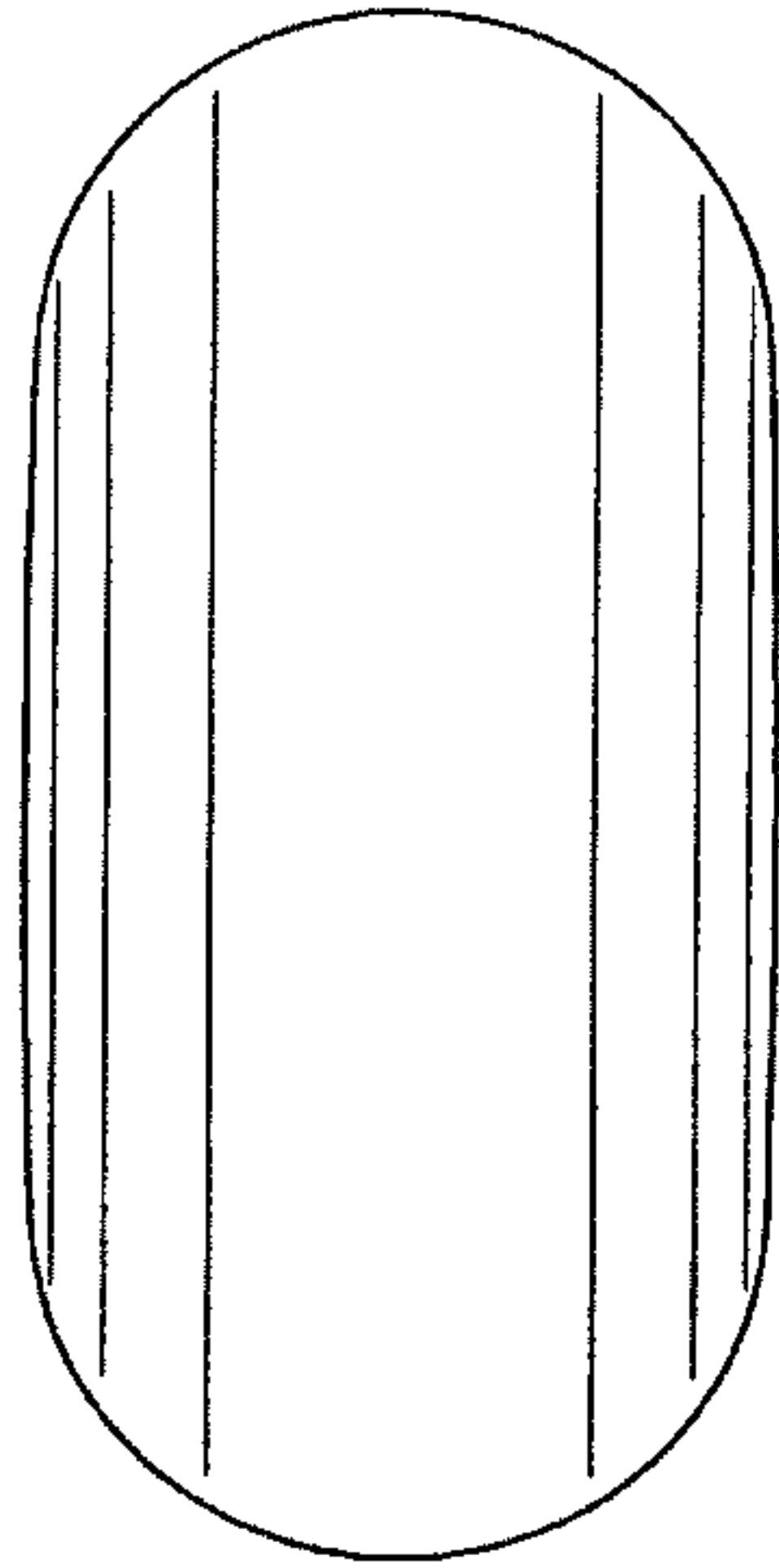

FIG. 4

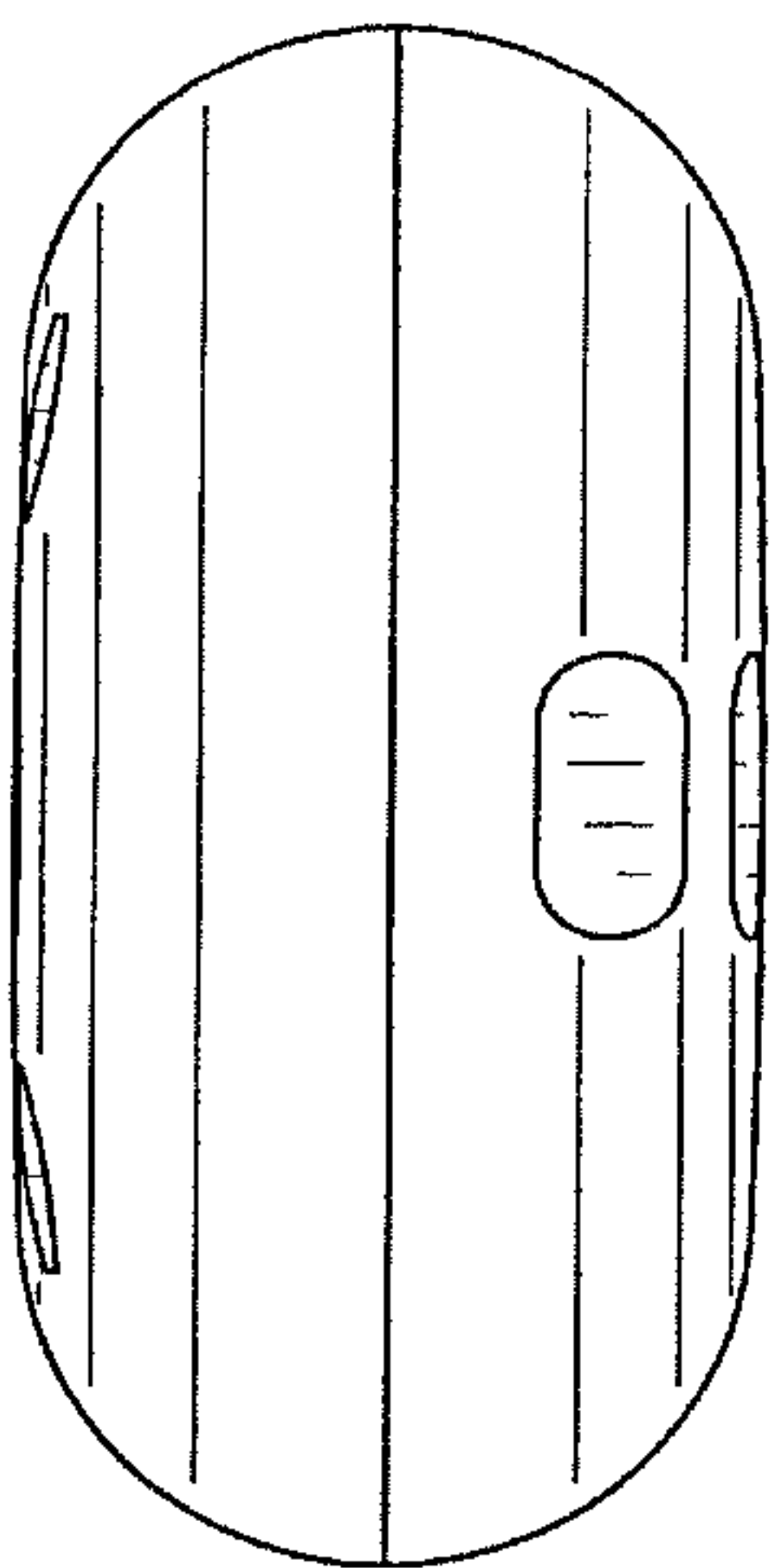

FIG. 5

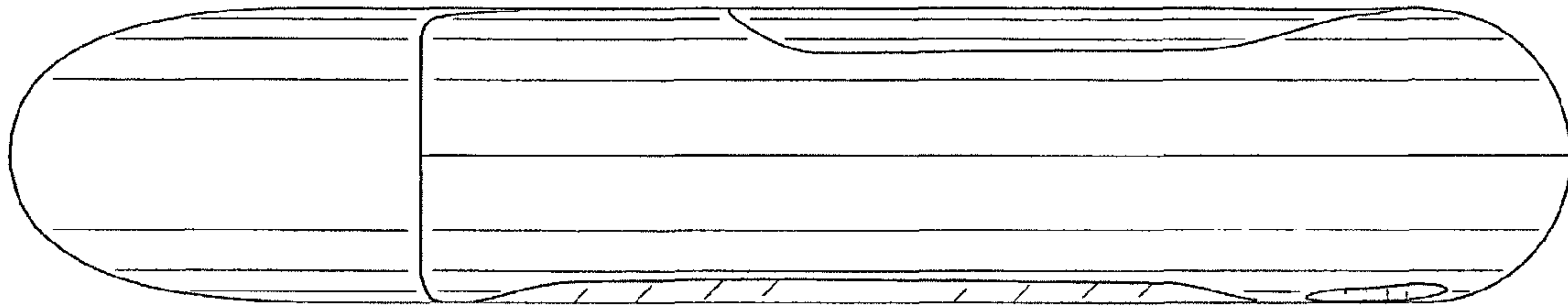

FIG. 6

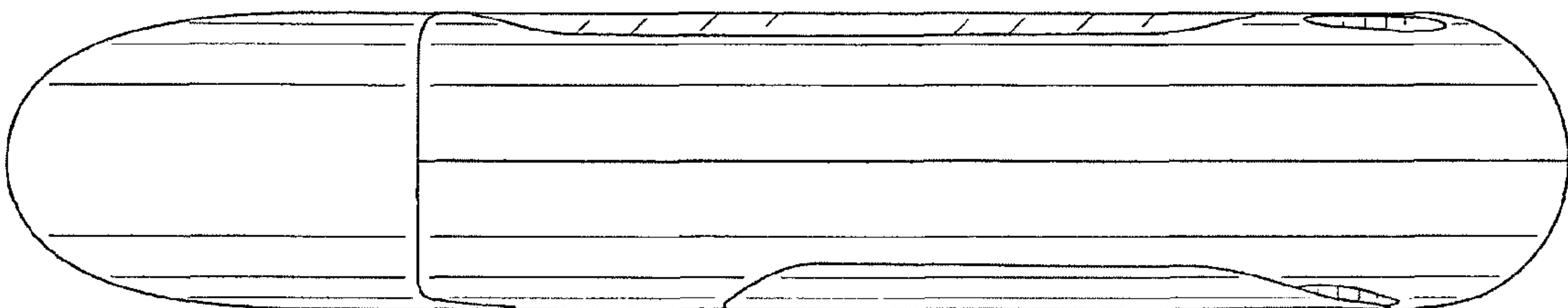

FIG. 7

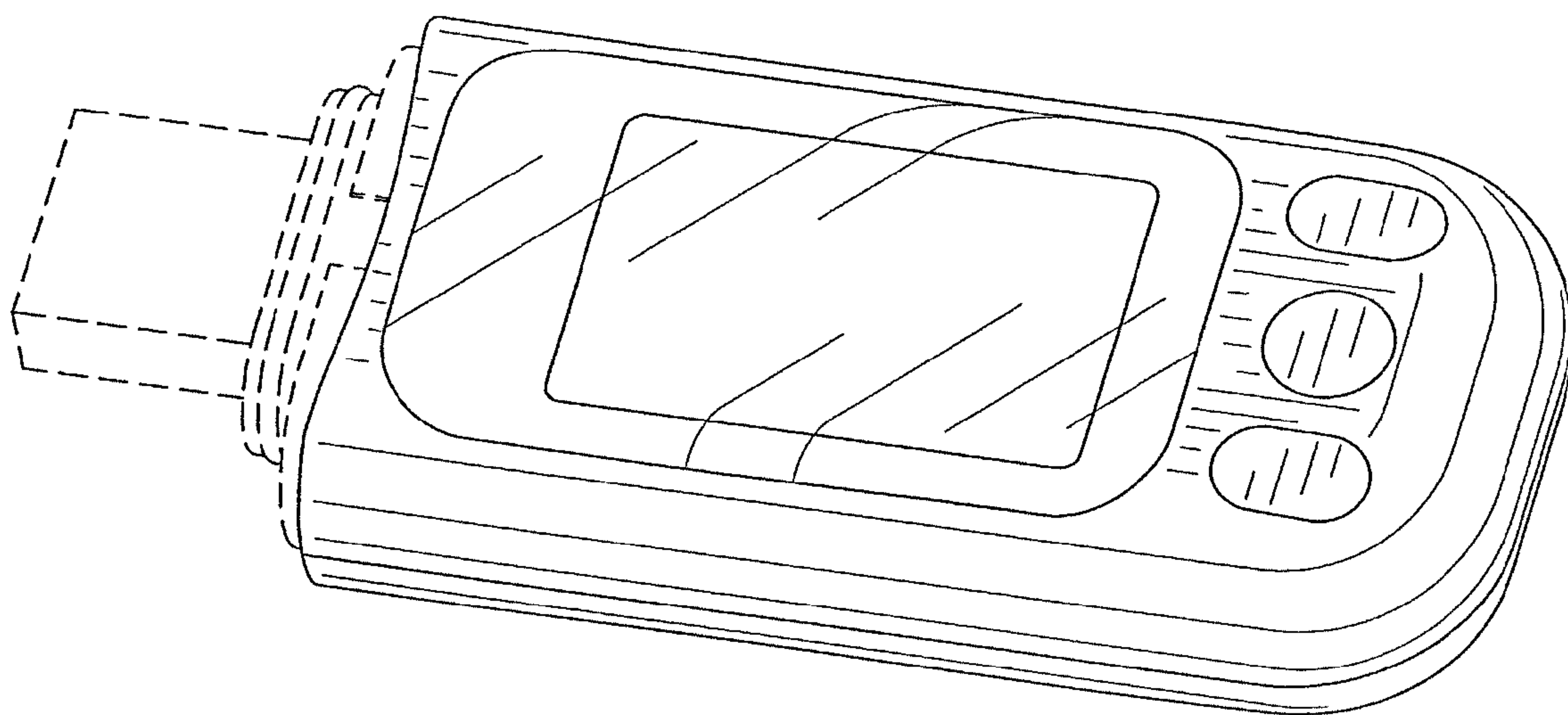

FIG. 8

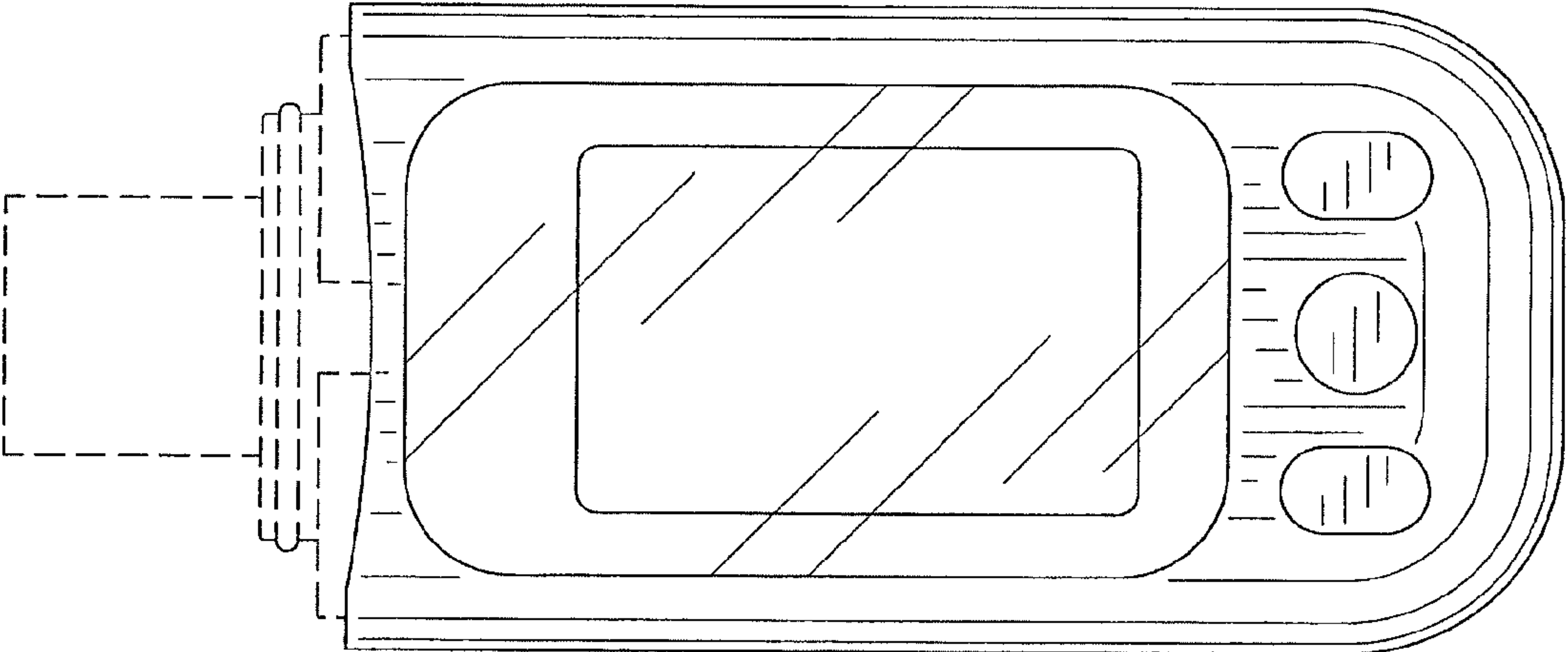

FIG. 9

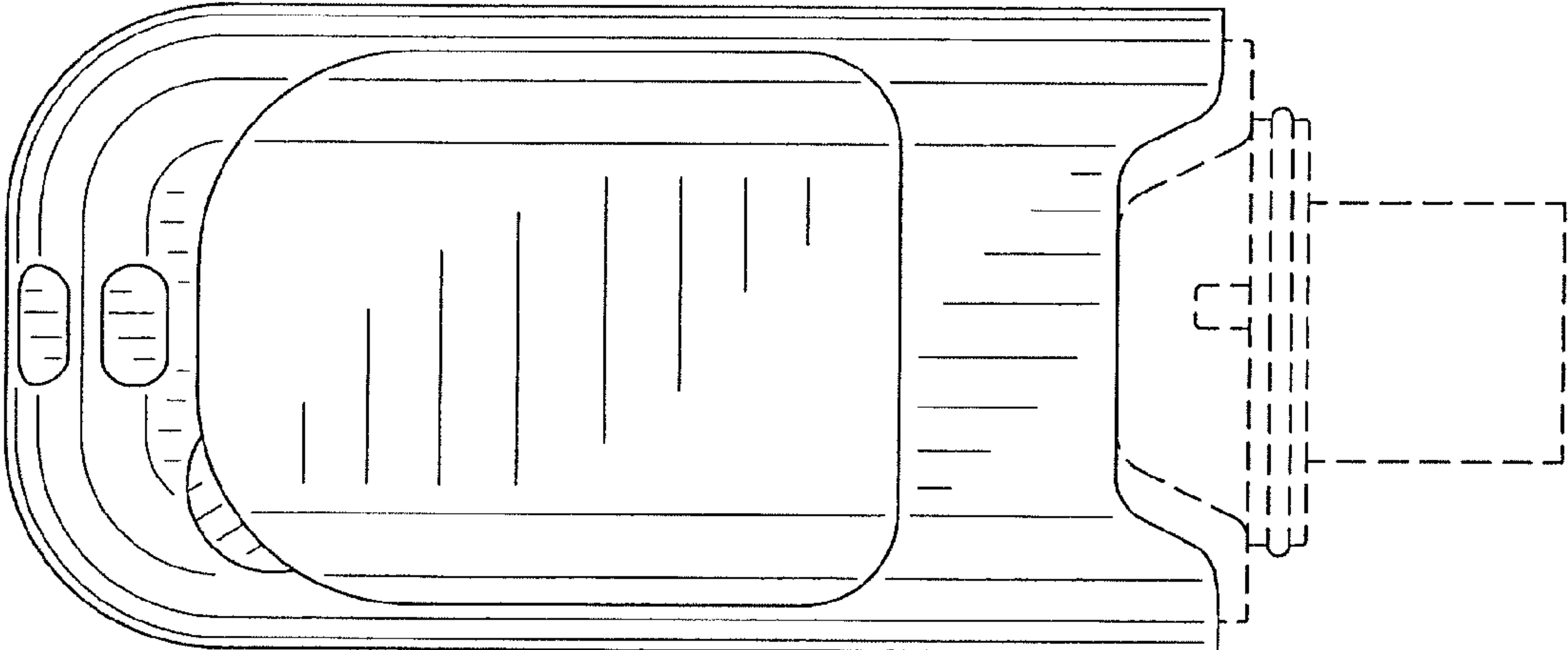

FIG. 10

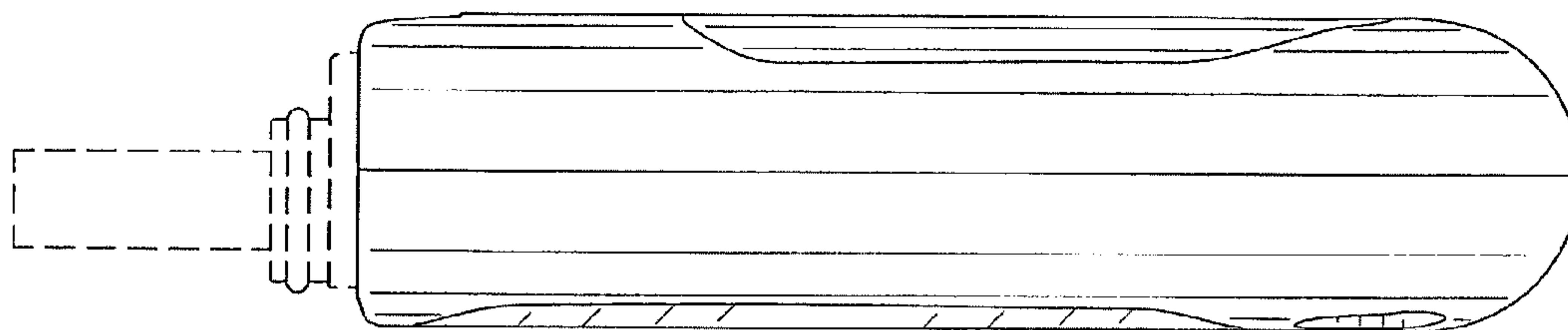

FIG. 11

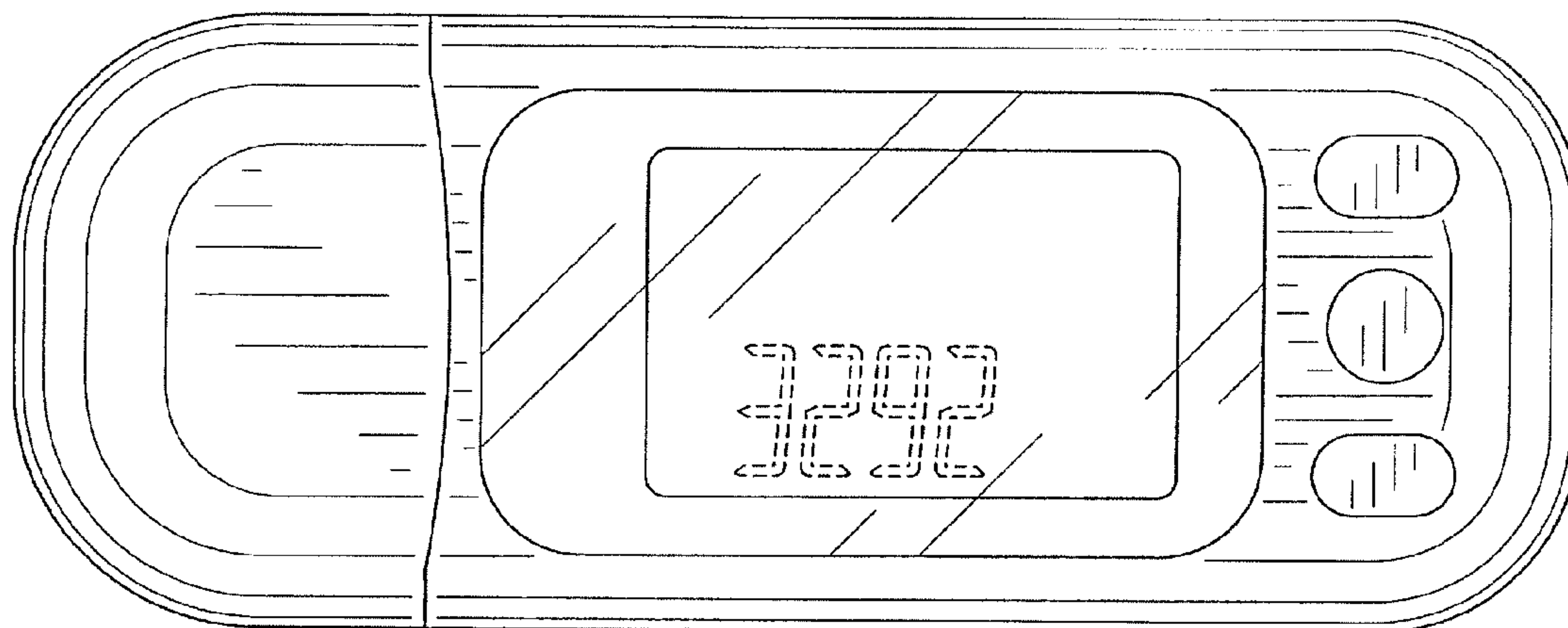

FIG. 12