



US00D682563S

(12) **United States Design Patent**
Goldberg

(10) **Patent No.:** **US D682,563 S**

(45) **Date of Patent:** **** May 21, 2013**

(54) **VEHICLE SAFETY SEAT**

(71) Applicant: **Ely Goldberg**, Dollard des Ormeaux (CA)

(72) Inventor: **Ely Goldberg**, Dollard des Ormeaux (CA)

(**) Term: **14 Years**

(21) Appl. No.: **29/434,288**

(22) Filed: **Oct. 11, 2012**

(51) **LOC (9) Cl.** **06-01**

(52) **U.S. Cl.**
USPC **D6/333**

(58) **Field of Classification Search**

USPC .. D6/333-335, 339, 491, 500-502; D12/129; D21/412, 419, 428; 280/30-31; 5/94, 98.1, 5/99.1, 101-102, 105, 655; 297/183.1-183.4, 297/184.15, 184.17, 250.1, 255, 256.15, 297/219.12, 463.1

See application file for complete search history.

(56) **References Cited**

U.S. PATENT DOCUMENTS

D262,242 S	12/1981	Molnar	
D338,343 S *	8/1993	Grange	D6/333
D360,307 S	7/1995	Kain	
D383,316 S	9/1997	Kain	
D453,631 S	2/2002	Kassai et al.	
D461,646 S	8/2002	Kain	
D537,640 S *	3/2007	Spence et al.	D6/333
D626,758 S	11/2010	Hartenstine et al.	
D630,448 S	1/2011	Xu et al.	
D632,501 S *	2/2011	Cymbalski et al.	D6/333
D636,190 S *	4/2011	Werschmidt et al.	D6/333
D653,463 S *	2/2012	Hartenstine et al.	D6/333
D655,925 S *	3/2012	Hartenstine et al.	D6/333
D661,500 S *	6/2012	Hutchinson et al.	D6/333
D662,720 S	7/2012	Gillett et al.	

OTHER PUBLICATIONS

United States Patent and Trademark Office; Notice of Allowance dated Dec. 20, 2012 issued in respect of U.S. Appl. No. 29/434,284; 6 pages.

* cited by examiner

Primary Examiner — Caron D Veynar

Assistant Examiner — Abraham Bahta

(74) *Attorney, Agent, or Firm* — Norton Rose Canada LLP

(57) **CLAIM**

The ornamental design for a vehicle safety seat, as shown and described.

DESCRIPTION

FIG. 1 is a top, front, and left side perspective view of a vehicle safety seat showing our new design in an upright position;

FIG. 2 is a front elevation view thereof;

FIG. 3 is a top plan view thereof;

FIG. 4 is a left side elevation view thereof;

FIG. 5 is a right side elevation view thereof;

FIG. 6 is a rear elevation view thereof;

FIG. 7 is a bottom plan view thereof;

FIG. 8 is a top, front, and left side perspective view of the vehicle safety seat of FIGS. 1-7 in a reclined position;

FIG. 9 is a front elevation view of the vehicle safety seat of FIGS. 1-7 in a reclined position;

FIG. 10 is a top plan view of the vehicle safety seat of FIGS. 1-7 in a reclined position;

FIG. 11 is a left side elevation view of the vehicle safety seat of FIGS. 1-7 in a reclined position;

FIG. 12 is a right side elevation view of the vehicle safety seat of FIGS. 1-7 in a reclined position;

FIG. 13 is a rear elevation view of the vehicle safety seat of FIGS. 1-7 in a reclined position; and,

FIG. 14 is a bottom plan view of the vehicle safety seat of FIGS. 1-7 in a reclined position.

The broken lines shown throughout the drawing views are for illustrative purposes only and form no part of the claimed design.

1 Claim, 14 Drawing Sheets

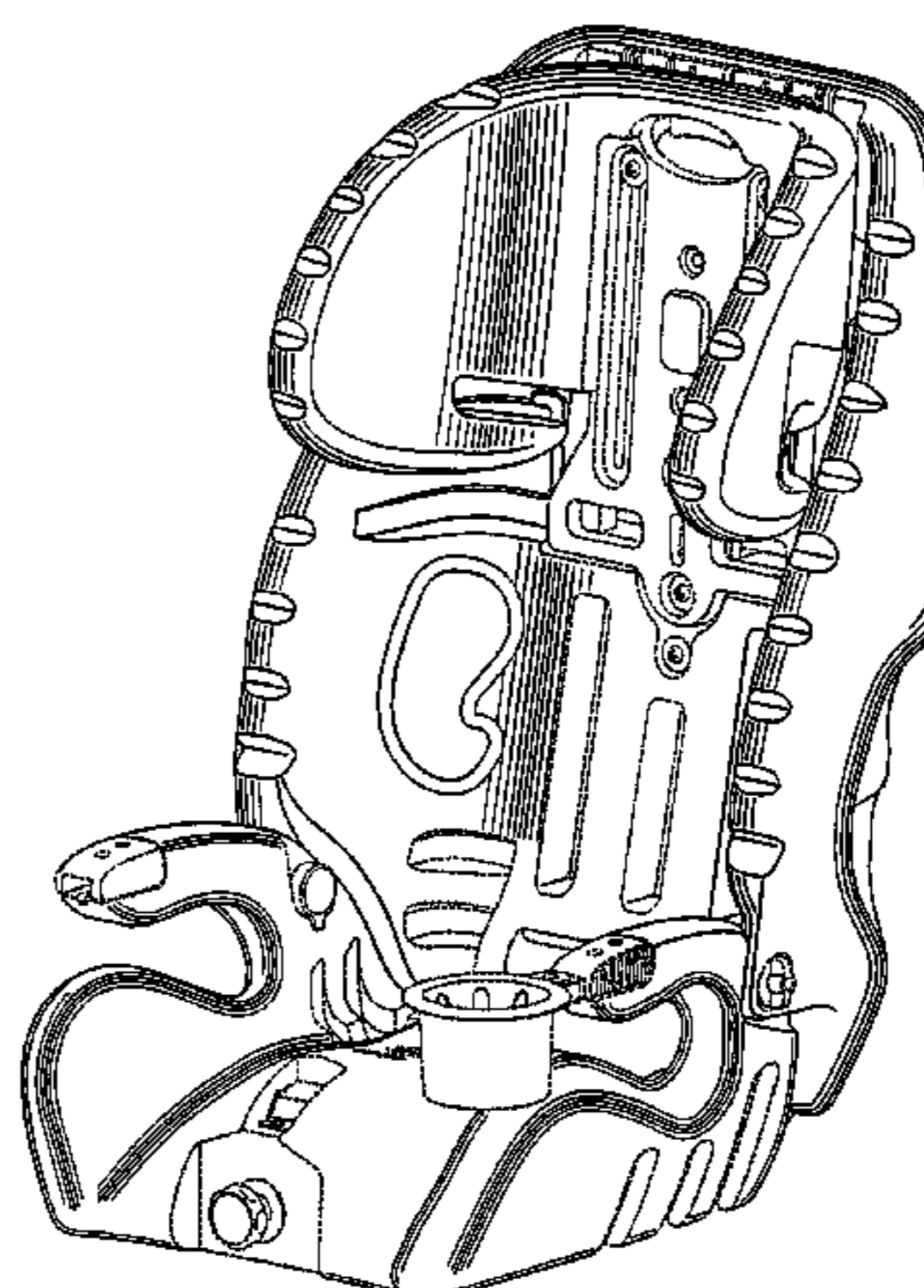
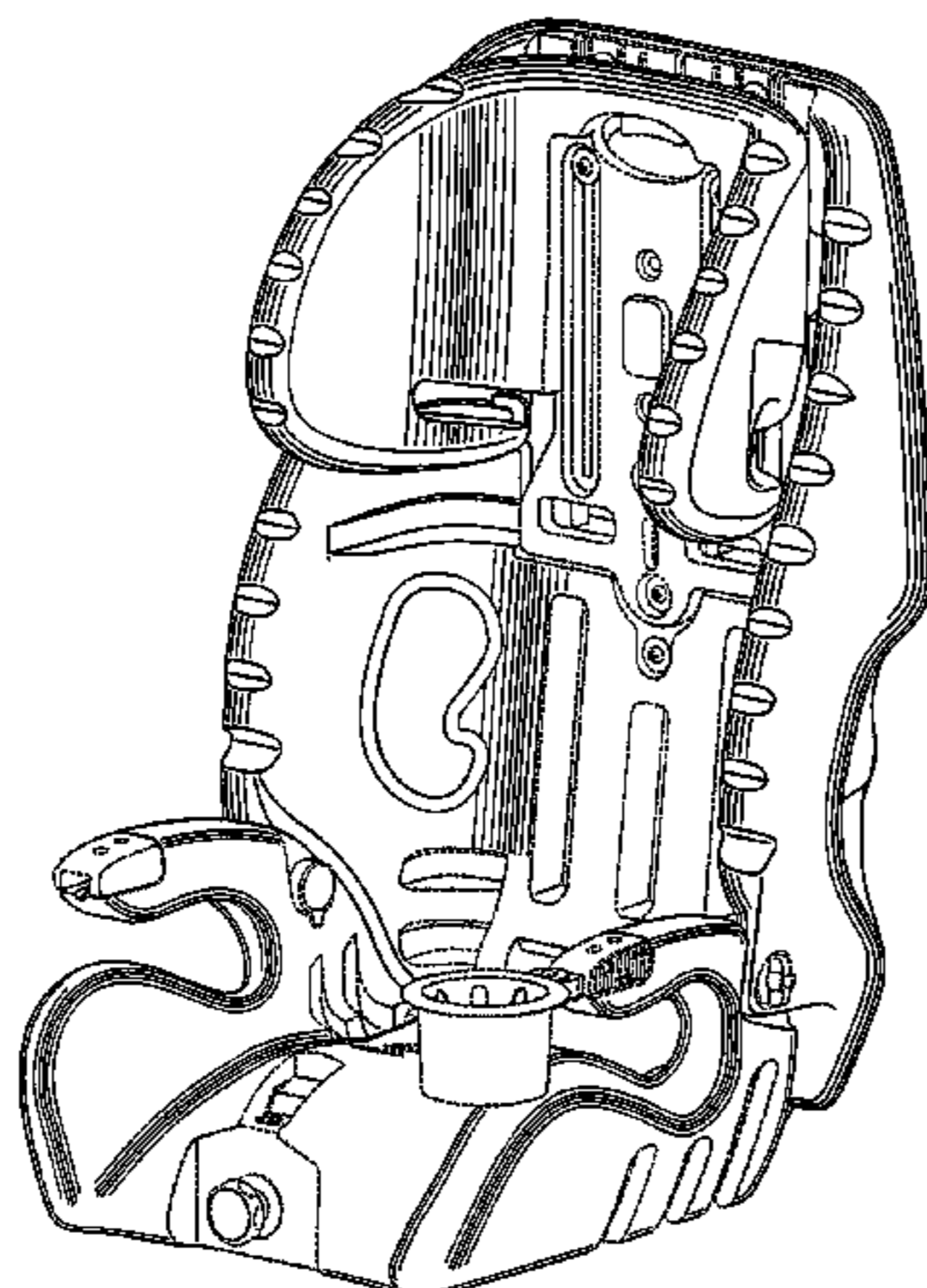

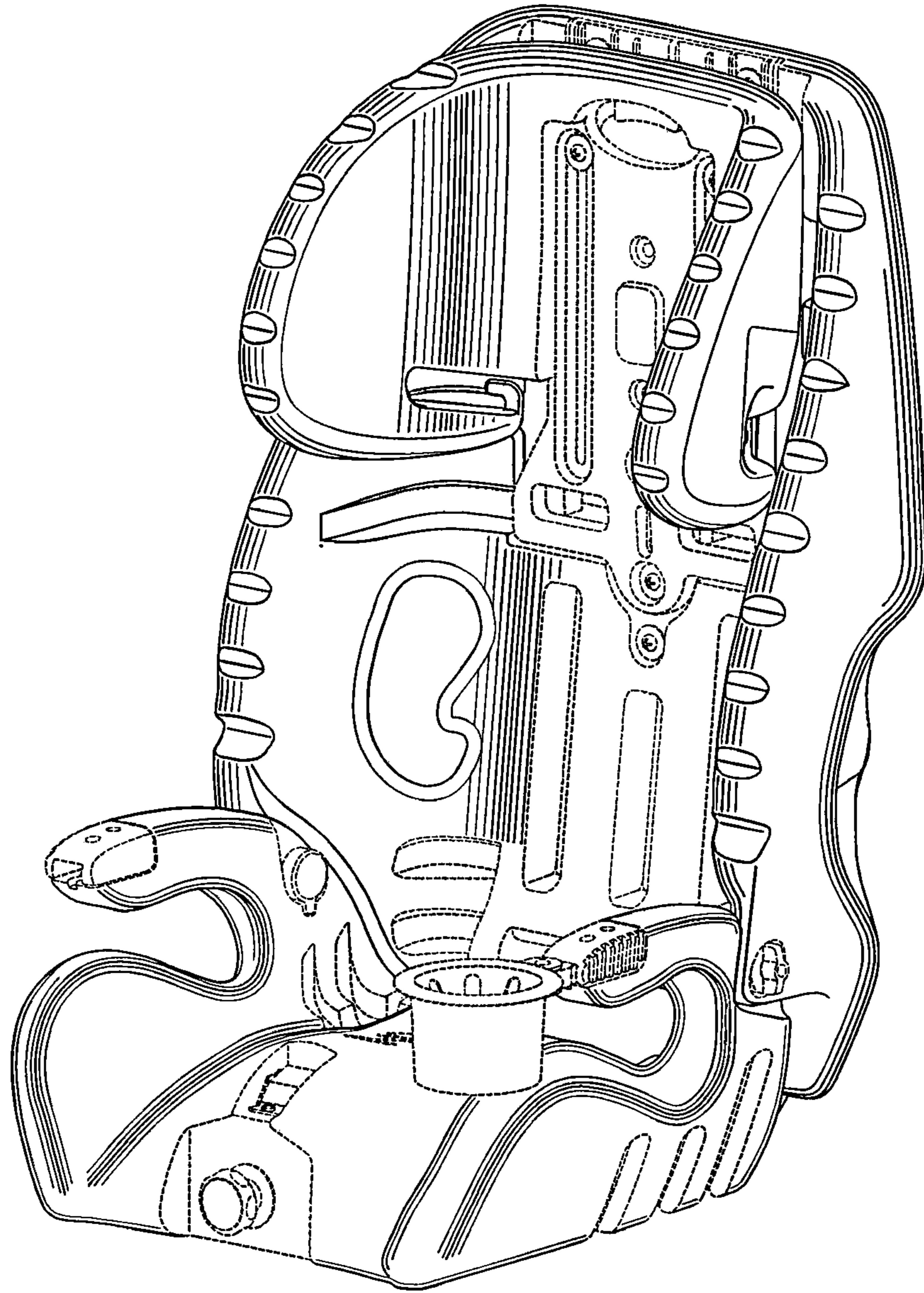

FIG. 1

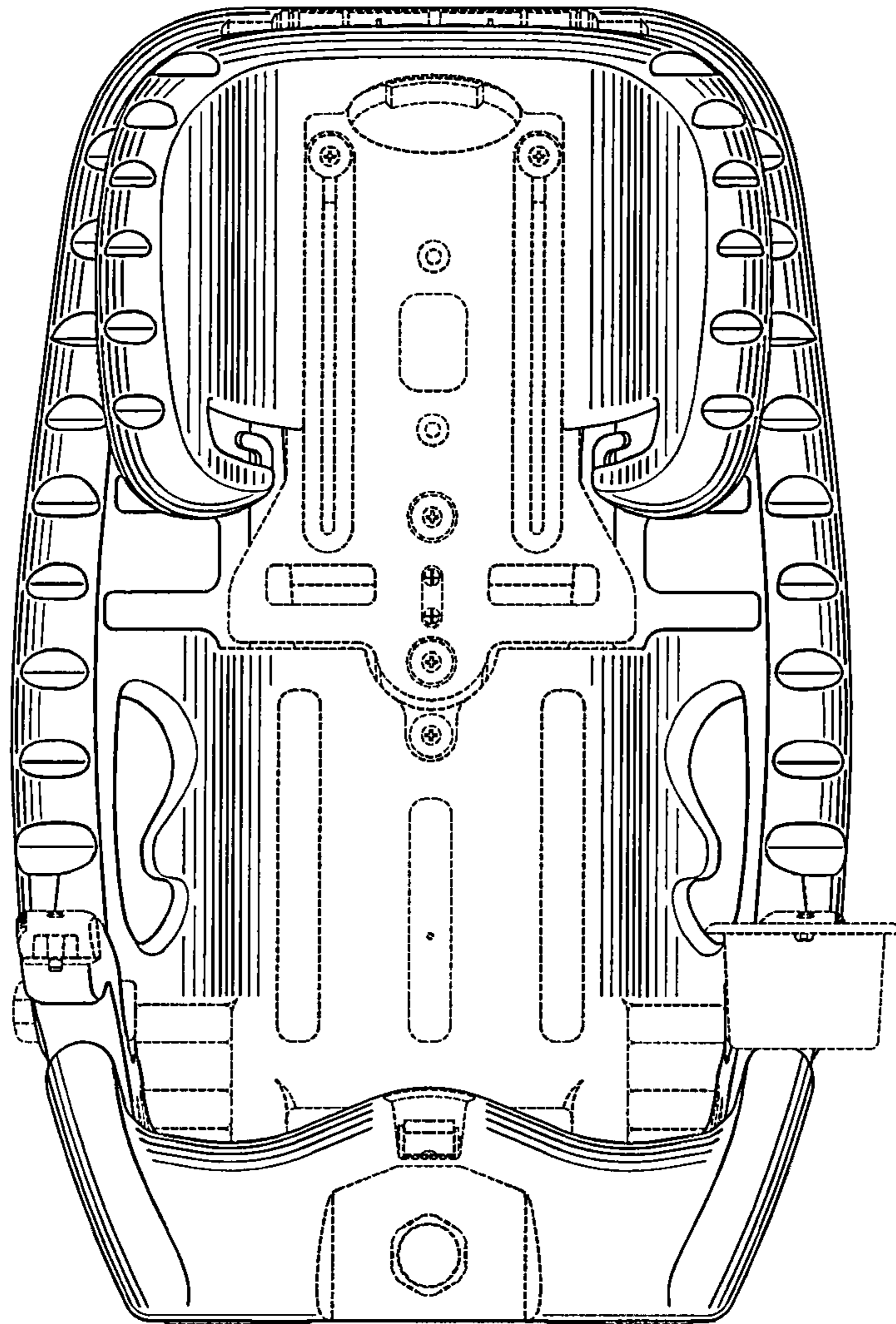

FIG. 2

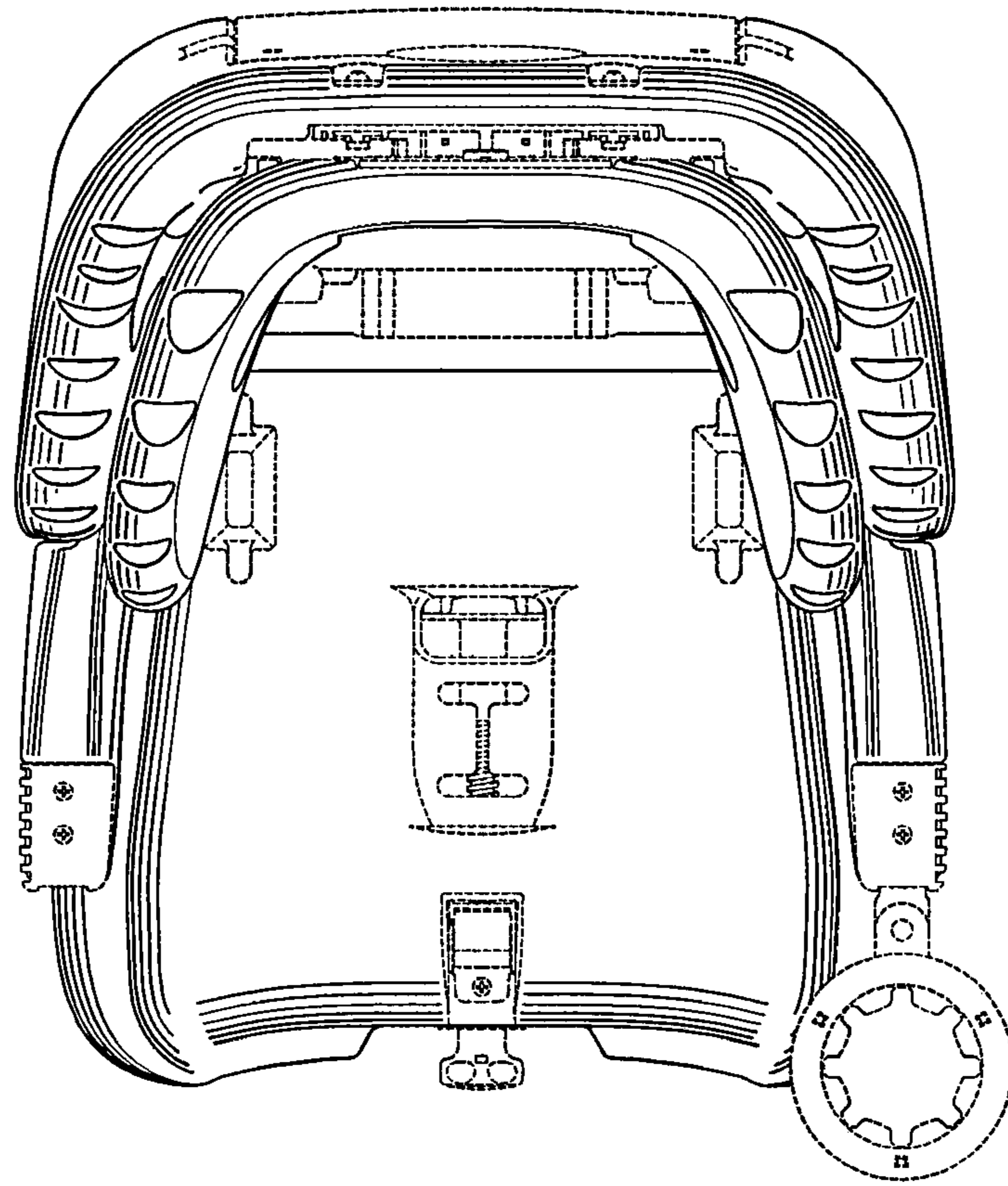

FIG. 3

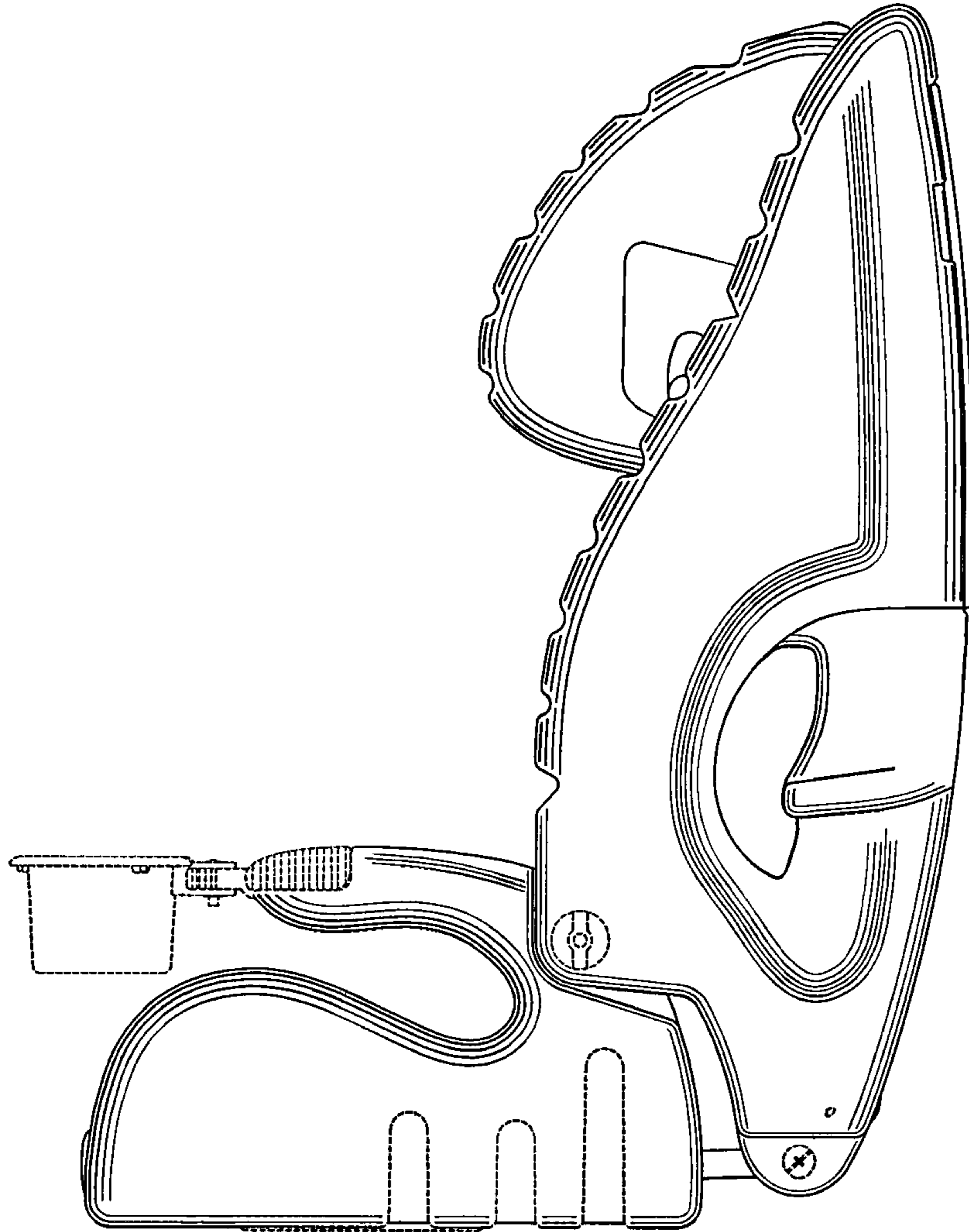

FIG. 4

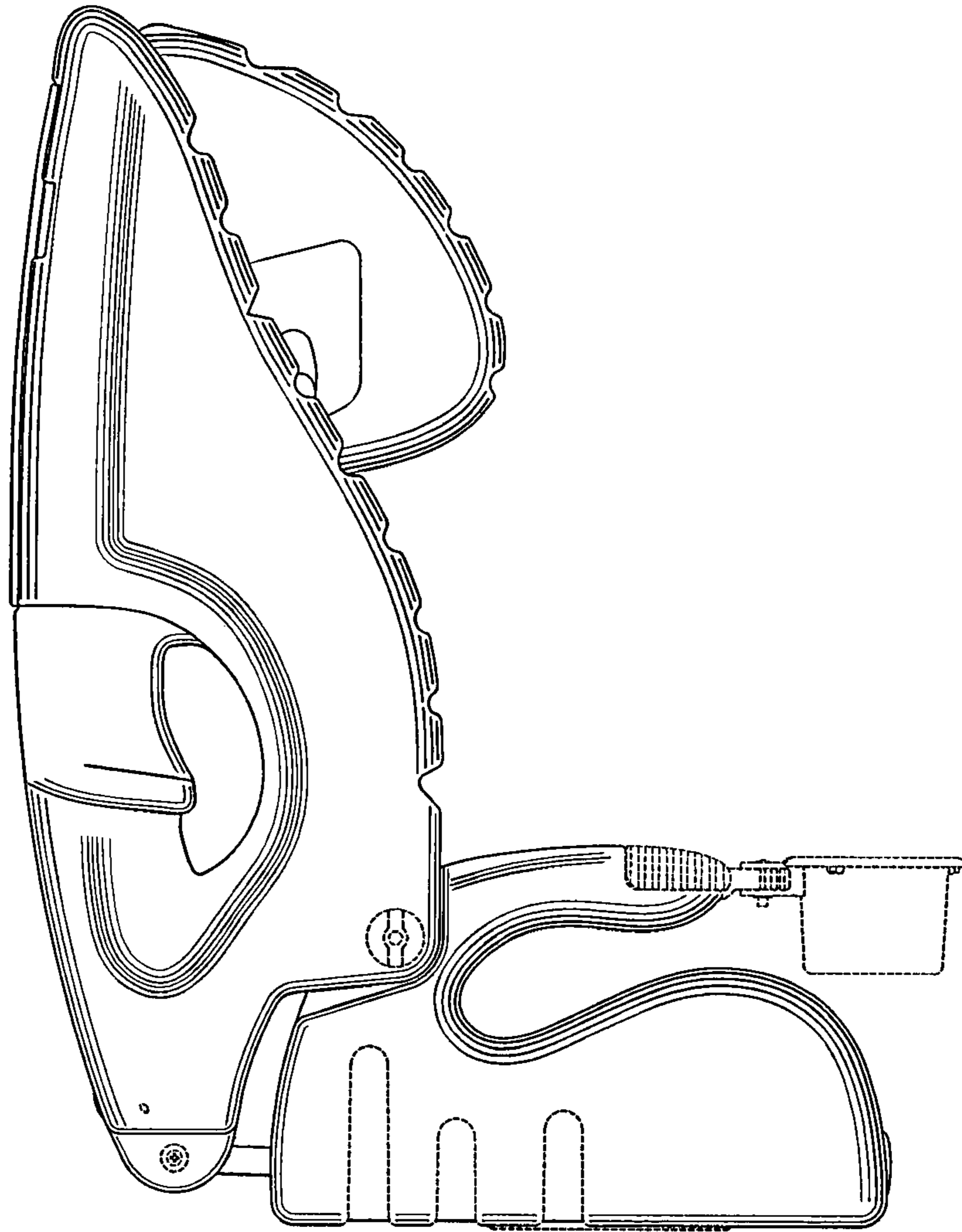

FIG. 5

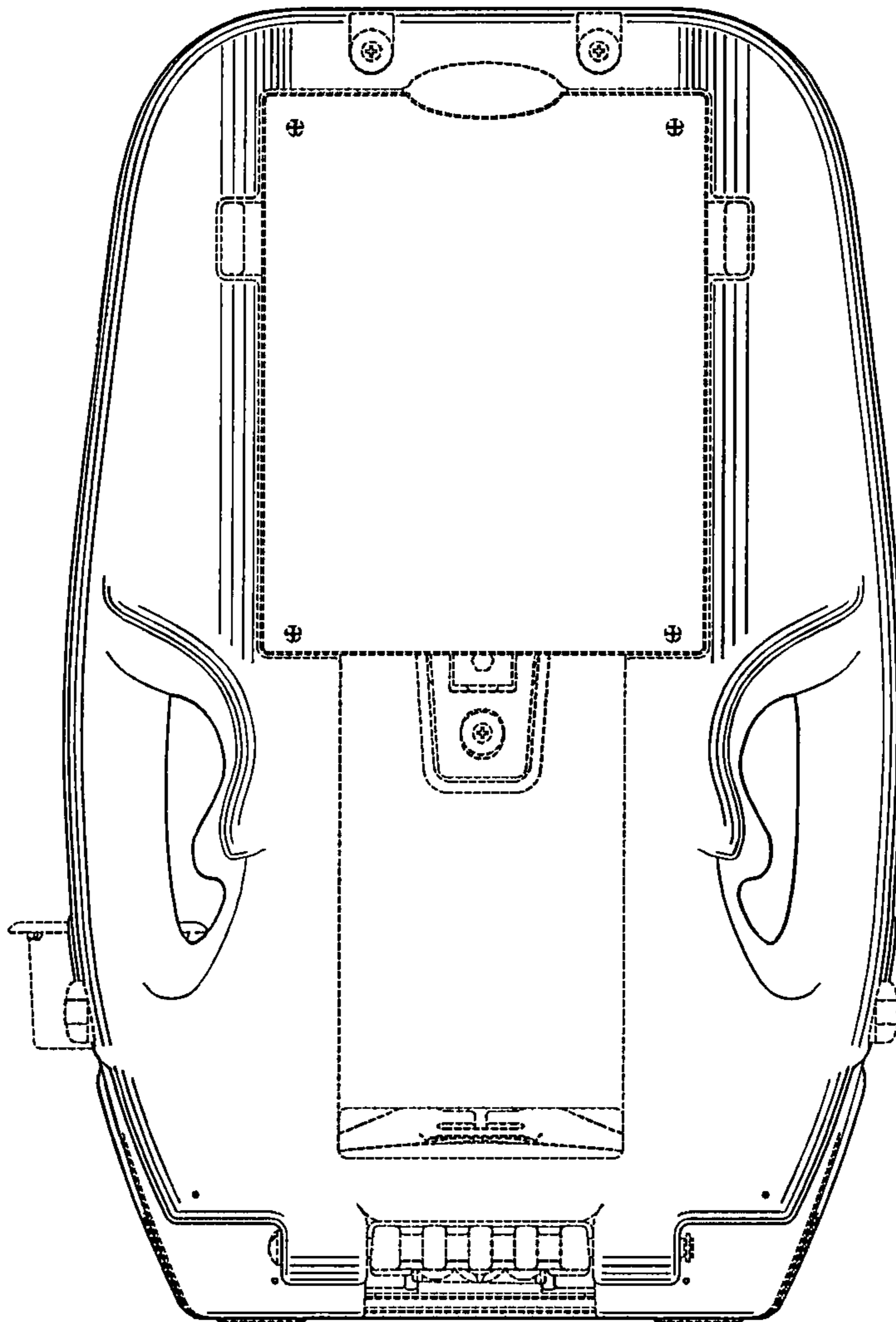

FIG. 6

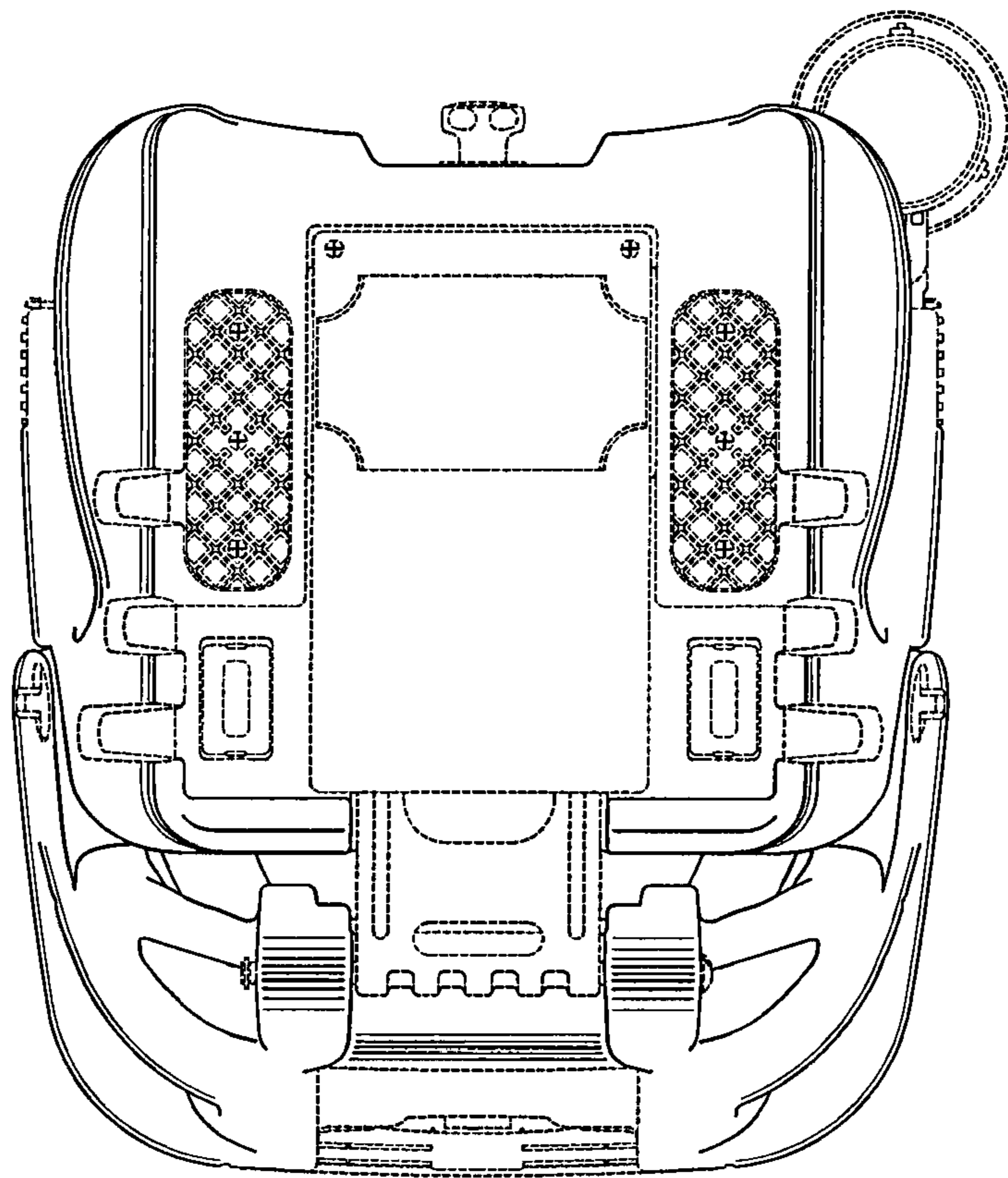

FIG. 7

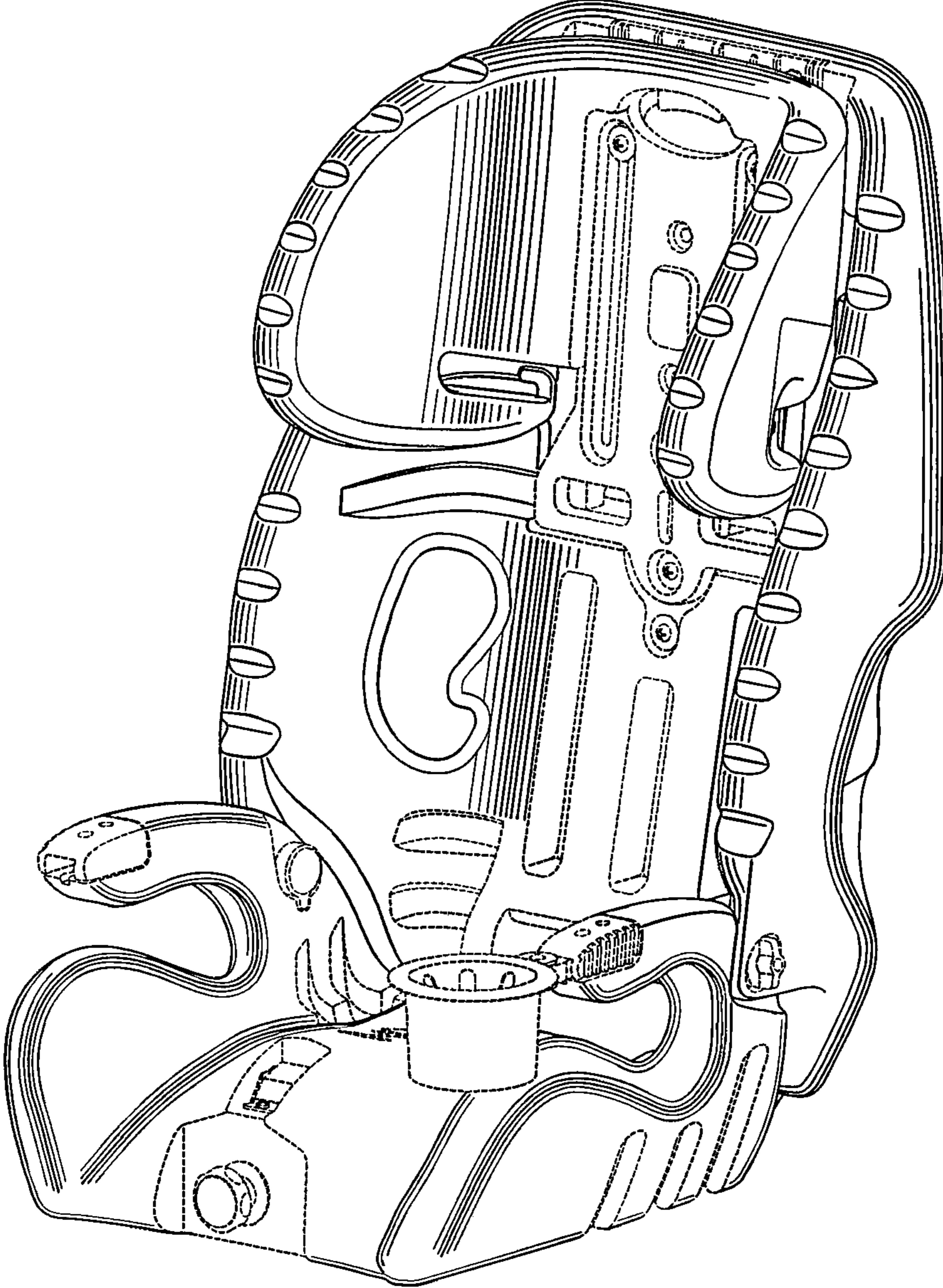

FIG. 8

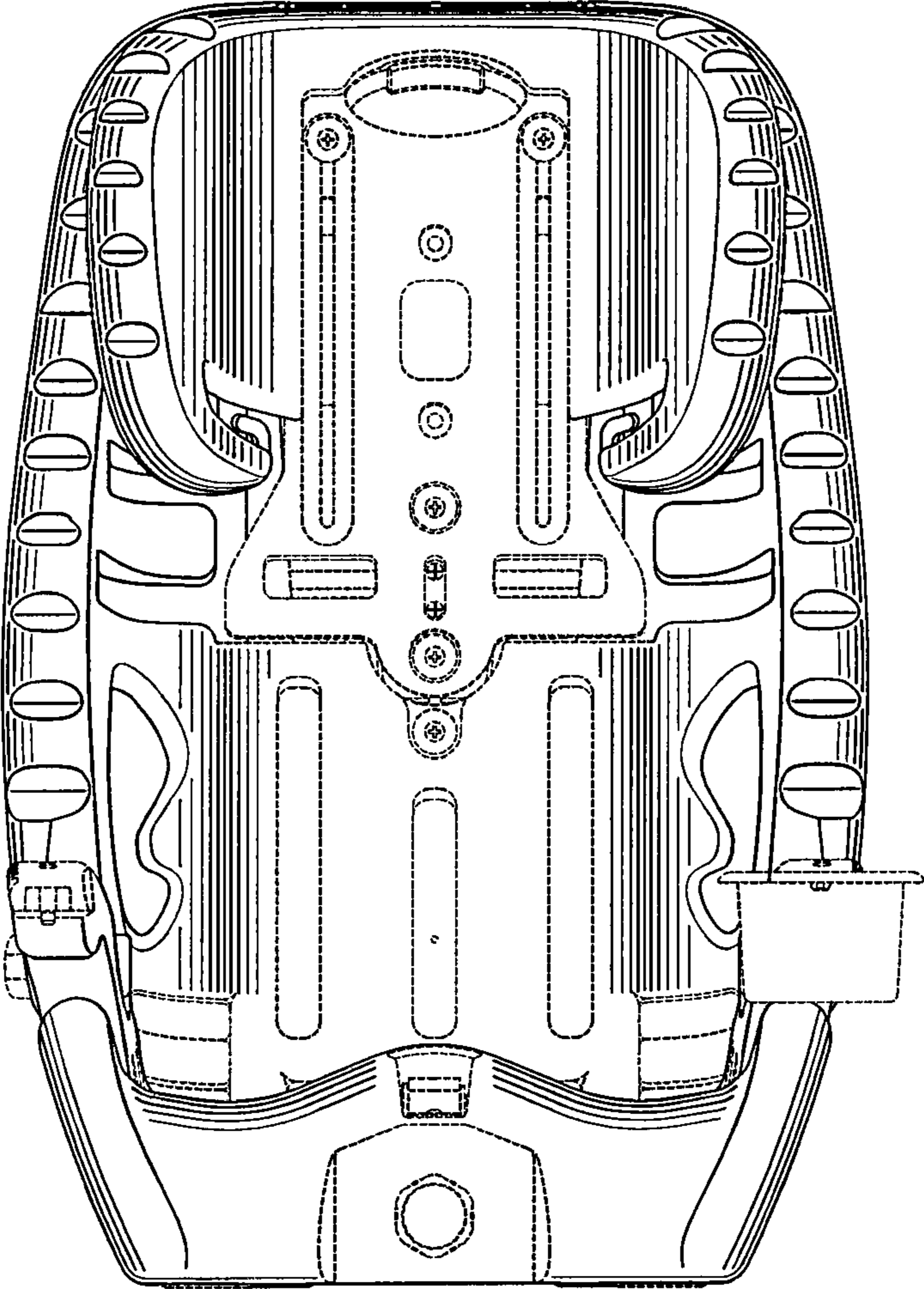

FIG. 9

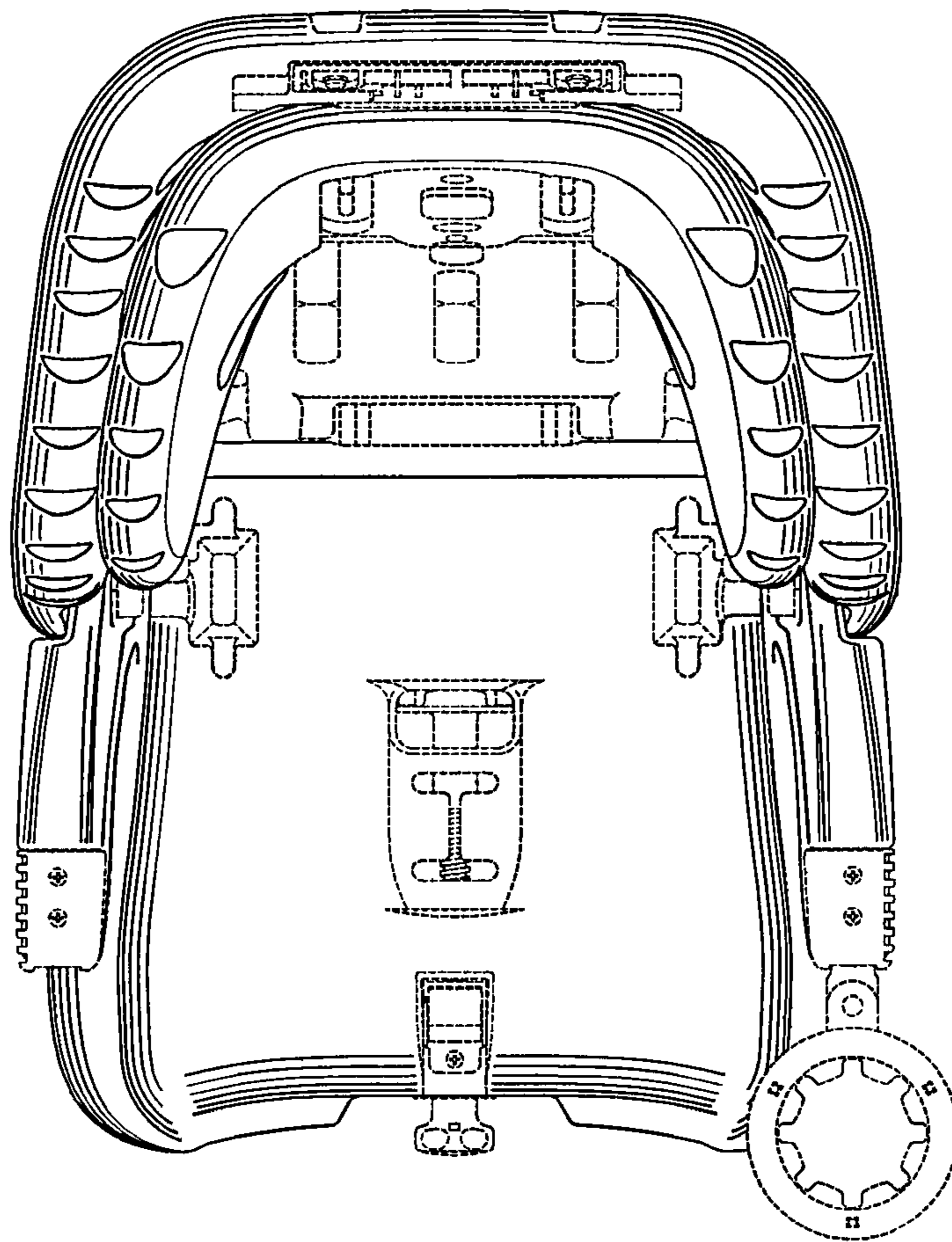

FIG. 10

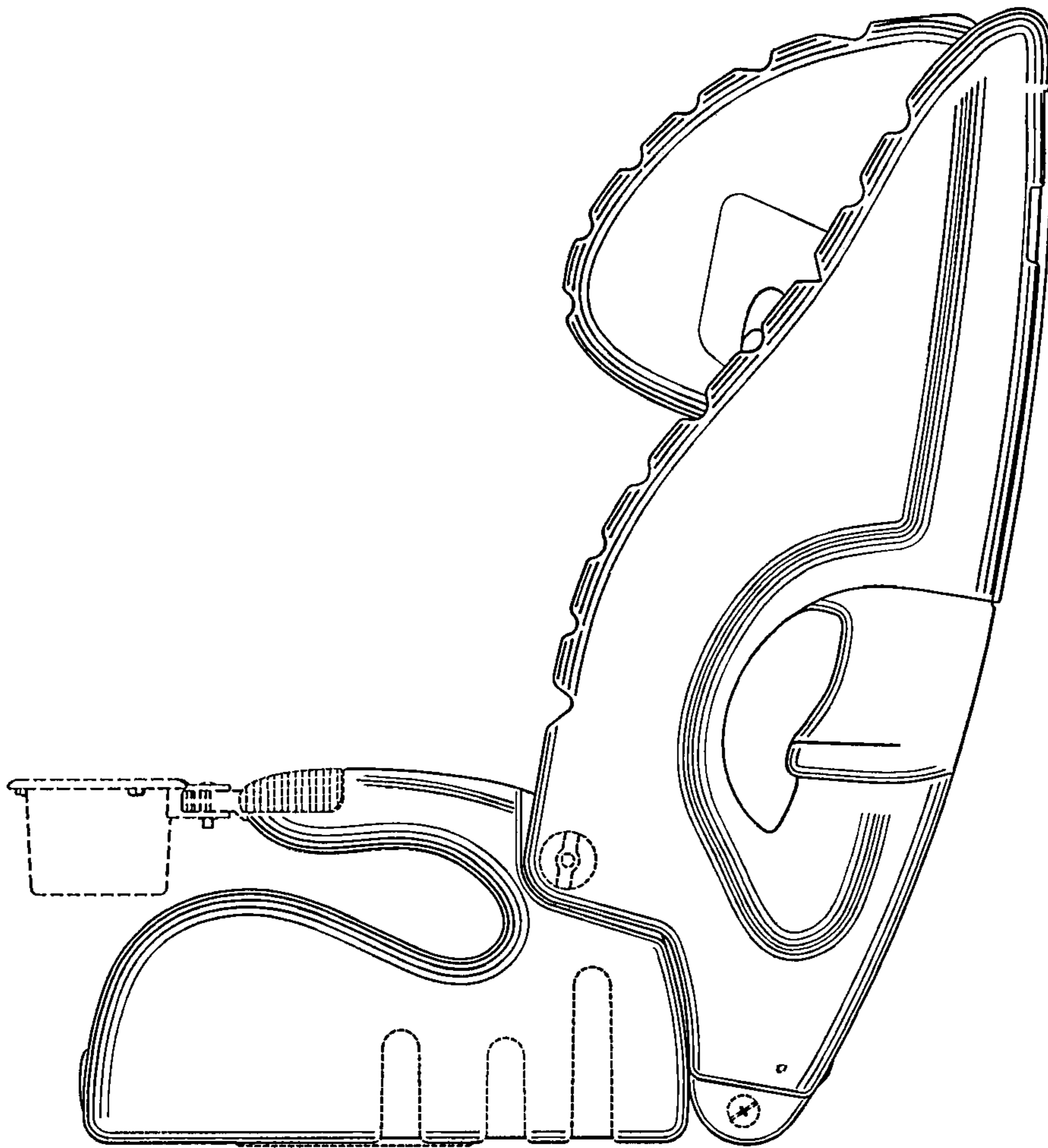

FIG. 11

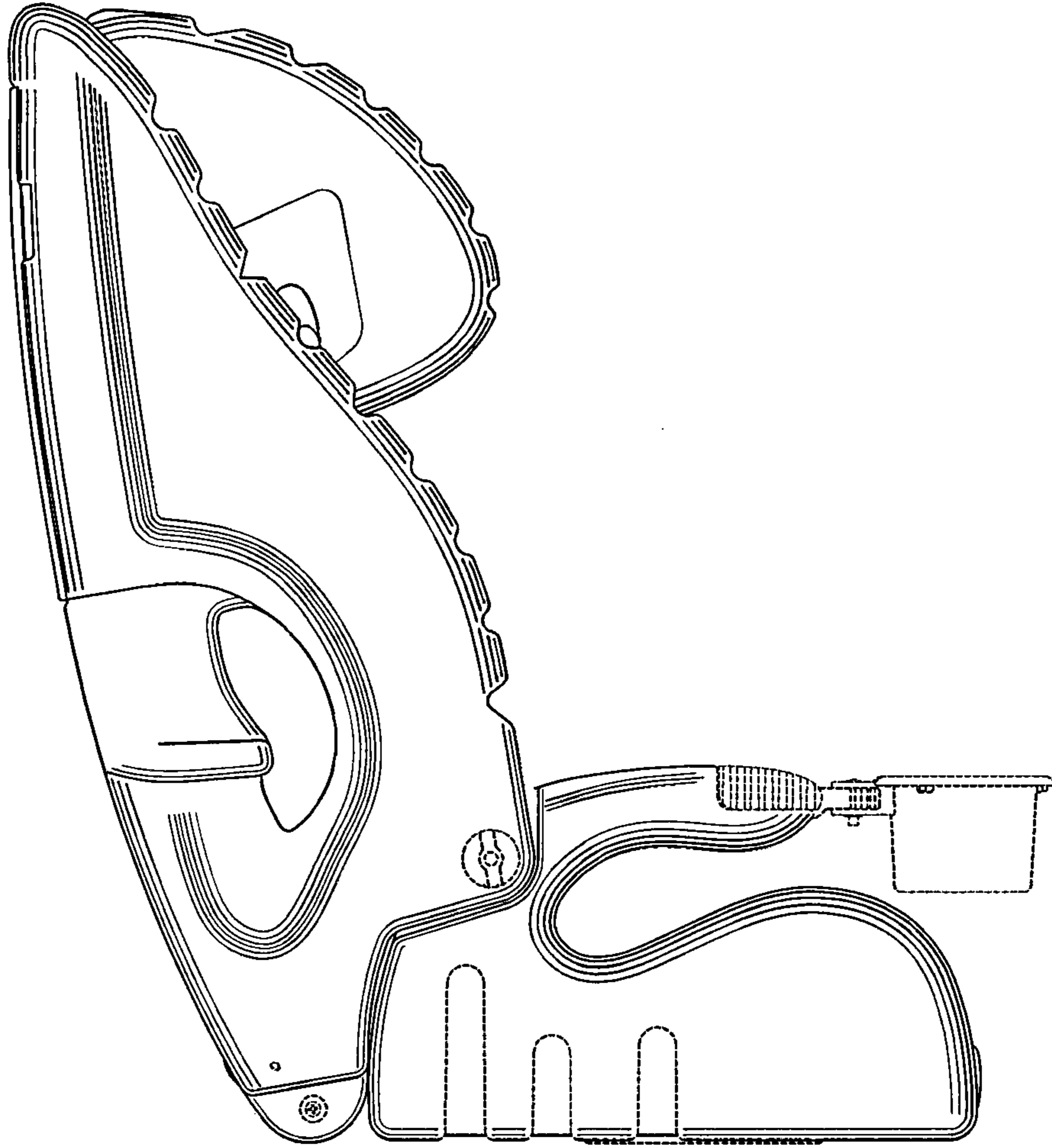

FIG. 12

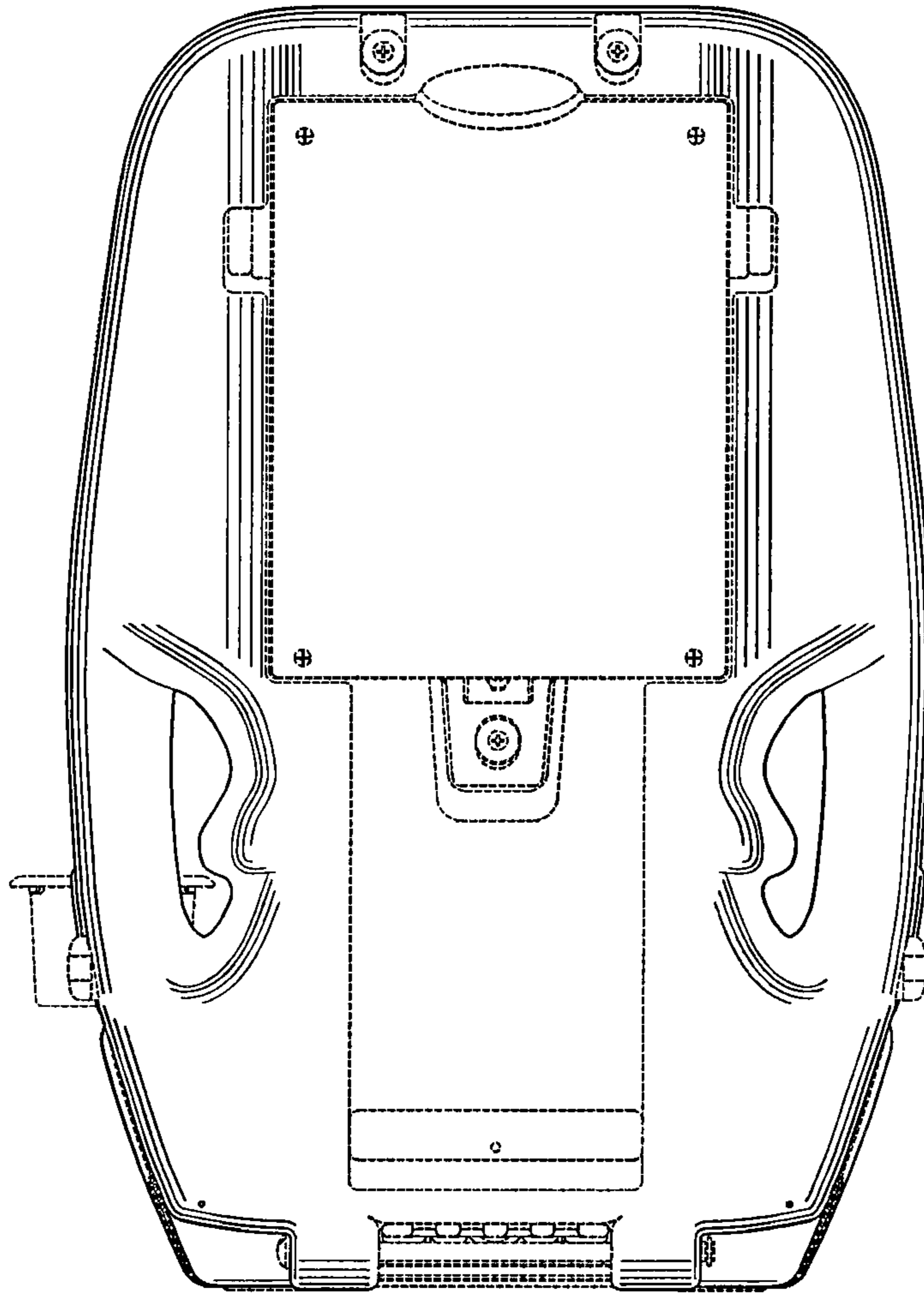

FIG. 13

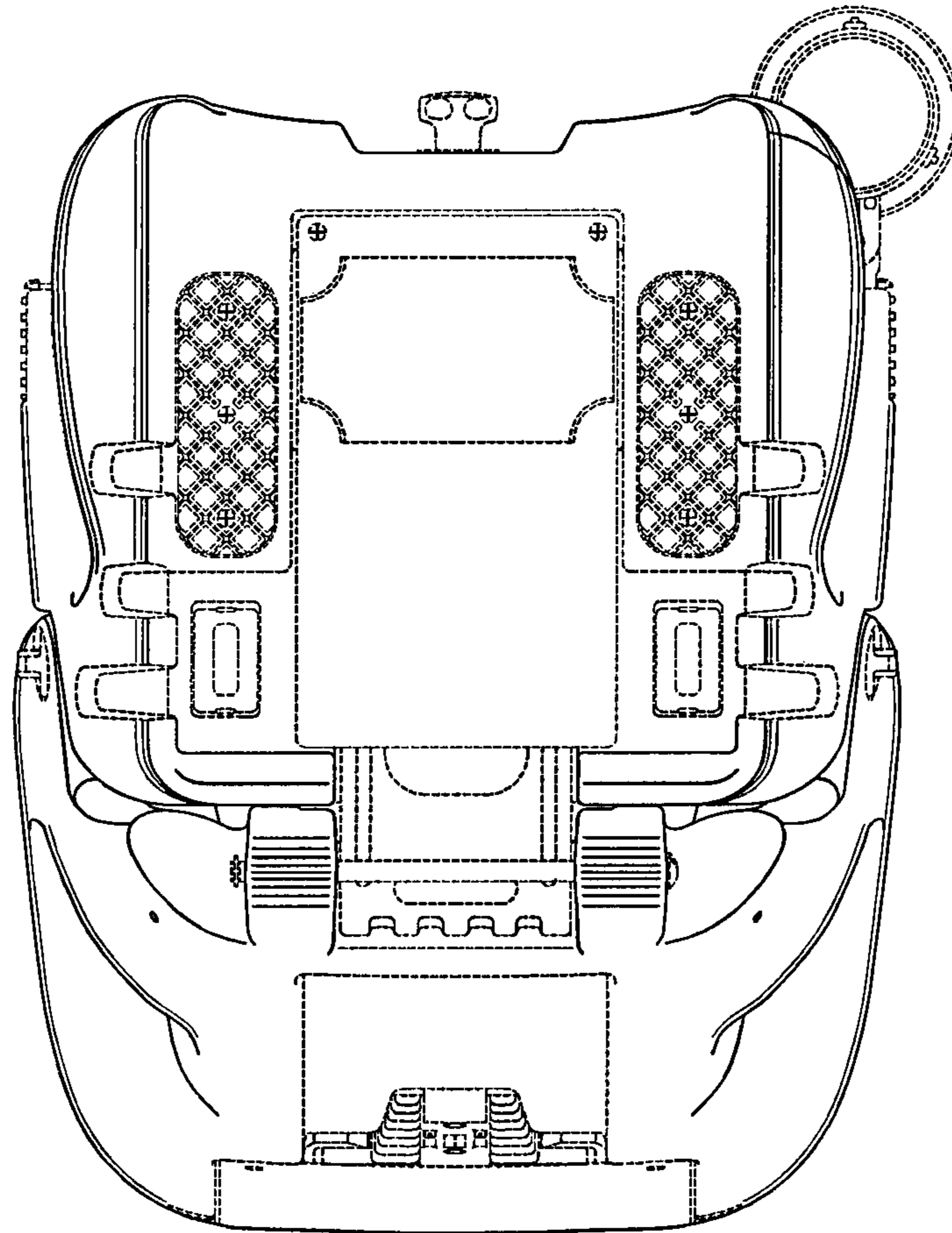

FIG. 14