



US00D682159S

(12) **United States Design Patent**  
**Aubé et al.**

(10) **Patent No.:** **US D682,159 S**  
(45) **Date of Patent:** **\*\* May 14, 2013**

(54) **UPPER FRAME OF A TRACK SYSTEM FOR AN ALL-TERRAIN VEHICLE**

(75) Inventors: **Martin Aubé**, St-Bruno (CA); **Jeremie Zuchoski**, Sherbrooke (CA)

(73) Assignee: **Camoplast Solideal Inc.**, Sherbrooke, Québec (CA)

(\*\*) Term: **14 Years**

(21) Appl. No.: **29/405,414**

(22) Filed: **Nov. 2, 2011**

(51) **LOC (9) Cl.** ..... **12-11**

(52) **U.S. Cl.**  
USPC ..... **D12/107; D12/114**

(58) **Field of Classification Search** ..... D12/1-3, D12/6-11, 107, 114; D15/24, 28; 180/9, 180/9.1, 9.21, 9.25, 9.26, 9.3, 180, 181, 189, 180/9.28, 44, 190-196, 182-186; 280/5.22, 280/28.5, 844, 13, 28, 609; 305/120, 54, 305/46, 100, 131, 132, 135

See application file for complete search history.

(56) **References Cited**

**U.S. PATENT DOCUMENTS**

D298,018	S *	10/1988	Cartwright	.....	D12/3
6,095,275	A *	8/2000	Shaw	.....	180/185
6,401,847	B1 *	6/2002	Lykken	.....	180/9.1
D476,599	S *	7/2003	Whittington	.....	D12/7
D488,171	S *	4/2004	Juncker et al.	.....	D15/28
6,874,586	B2 *	4/2005	Boivin et al.	.....	180/9.26
D505,136	S *	5/2005	Brazier	.....	D15/28
D528,133	S *	9/2006	Brazier	.....	D15/28
7,131,508	B2 *	11/2006	Brazier	.....	180/9.21
D556,791	S *	12/2007	Brazier	.....	D15/28
7,497,530	B2 *	3/2009	Bessette	.....	305/135
7,597,161	B2 *	10/2009	Brazier	.....	180/9.3
7,708,092	B2 *	5/2010	Despres	.....	180/9.5
2012/0104840	A1	5/2012	Zuchoski et al.		

**OTHER PUBLICATIONS**

“ATV/UTV Track Systems 2009-2010 Catalog”, Camoplast, Inc., Aug. 2009 (8 pages).

\* cited by examiner

*Primary Examiner* — Susan M Lee

*Assistant Examiner* — Linda G Brooks

(74) *Attorney, Agent, or Firm* — Fish & Richardson P.C.

(57) **CLAIM**

We claim the ornamental design for an upper frame of a track system for an all-terrain vehicle, as shown and described.

**DESCRIPTION**

FIG. 1 is a perspective view of an upper frame of a track system for an all-terrain vehicle according to the present design;

FIG. 2 is a side elevational view of the upper frame of a track system for an all-terrain vehicle of FIG. 1;

FIG. 3 is a rear elevational view of the upper frame of a track system for an all-terrain vehicle of FIG. 1;

FIG. 4 is a front elevational view of the upper frame of a track system for an all-terrain vehicle of FIG. 1;

FIG. 5 is a top view of the upper frame of a track system for an all-terrain vehicle of FIG. 1;

FIG. 6 is a bottom view of the upper frame of a track system for an all-terrain vehicle of FIG. 1; and,

FIG. 7 is a side elevational view of the upper frame of a track system for an all-terrain vehicle shown in the context of its environment.

The outermost broken lines in the shape of a circle in FIGS. 1, 2, and 7 are boundary lines, while the other broken lines illustrate unclaimed environmental structure. None of the broken lines form part of the claimed design.

**1 Claim, 5 Drawing Sheets**

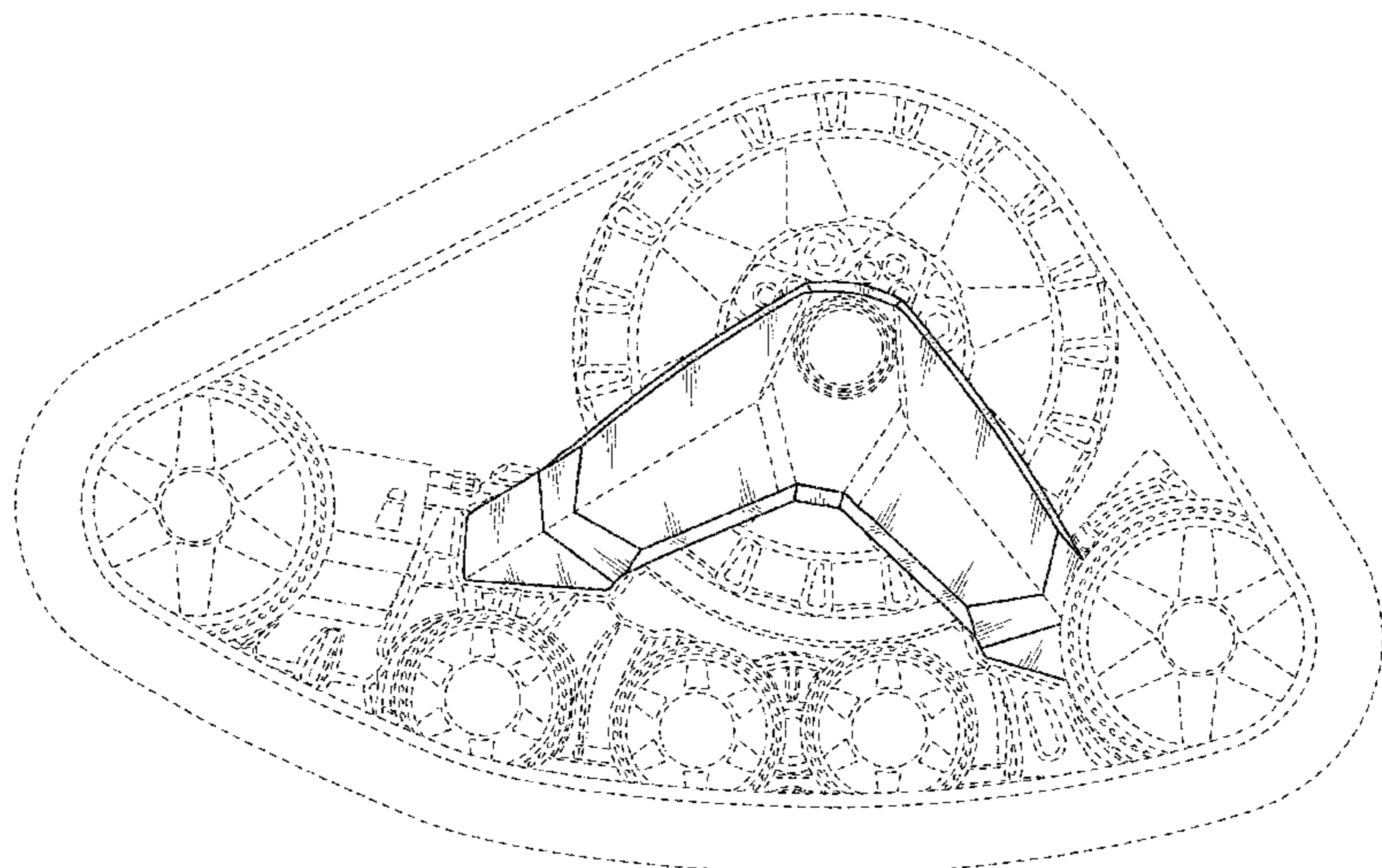
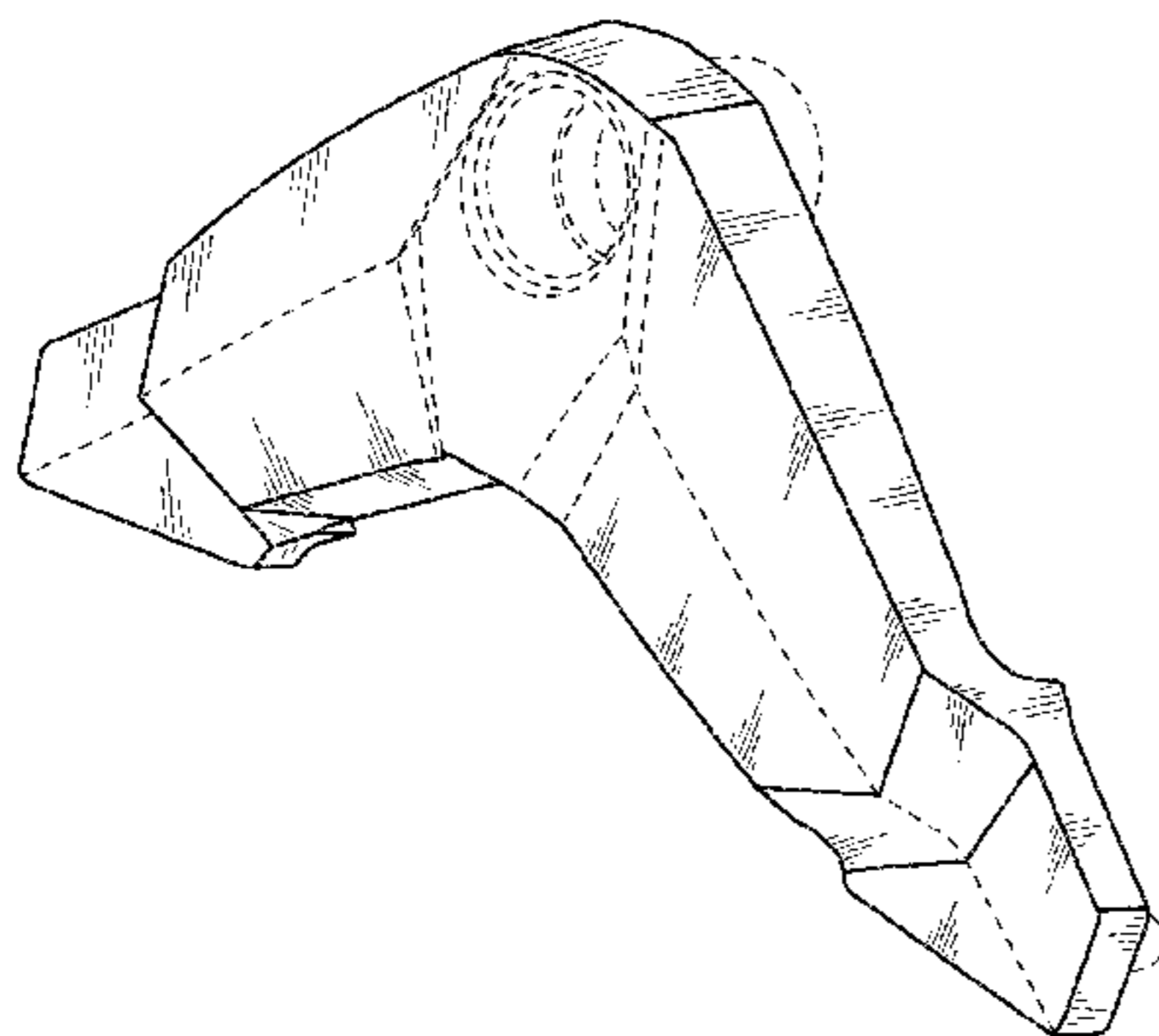

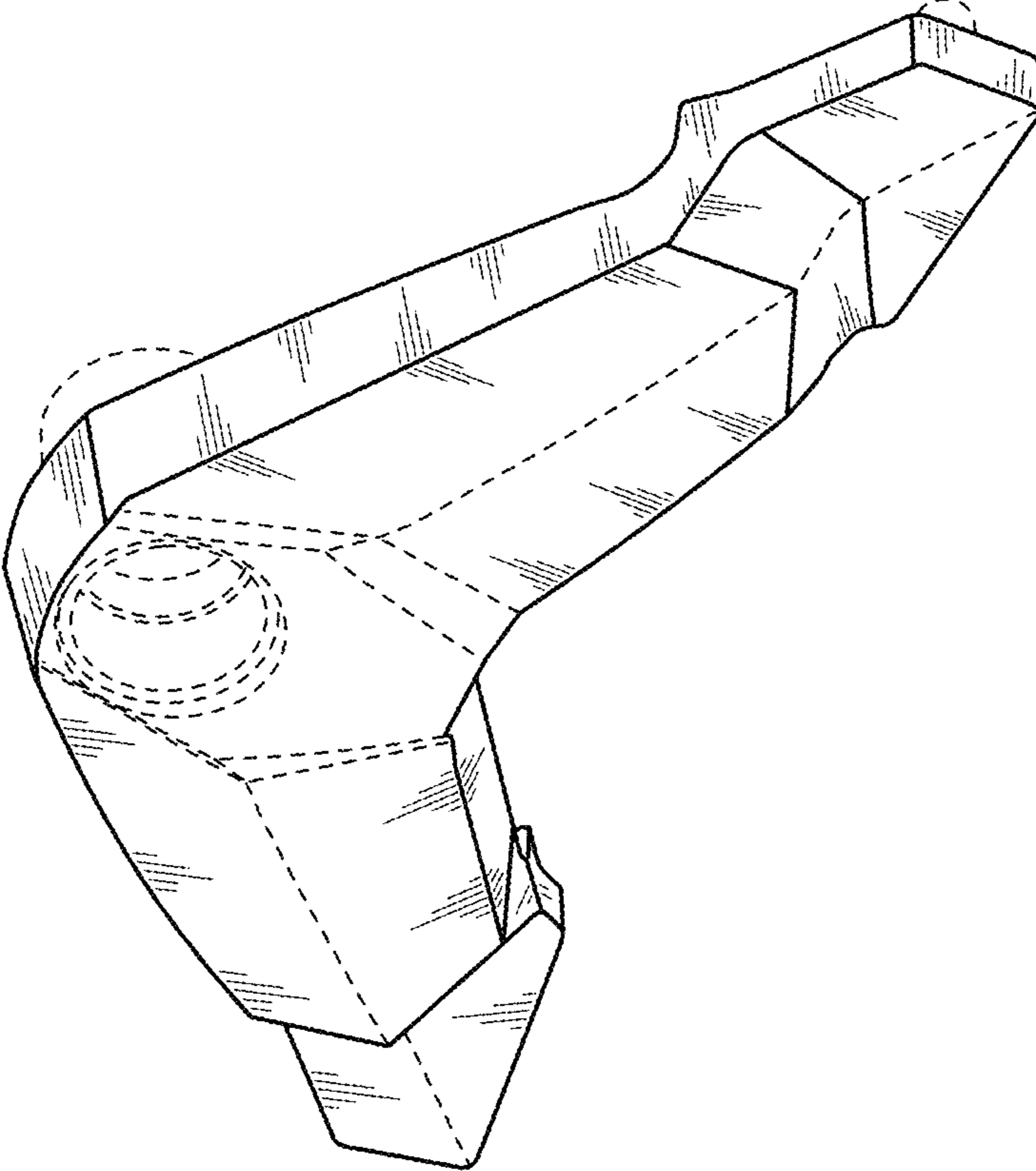

FIG. 1

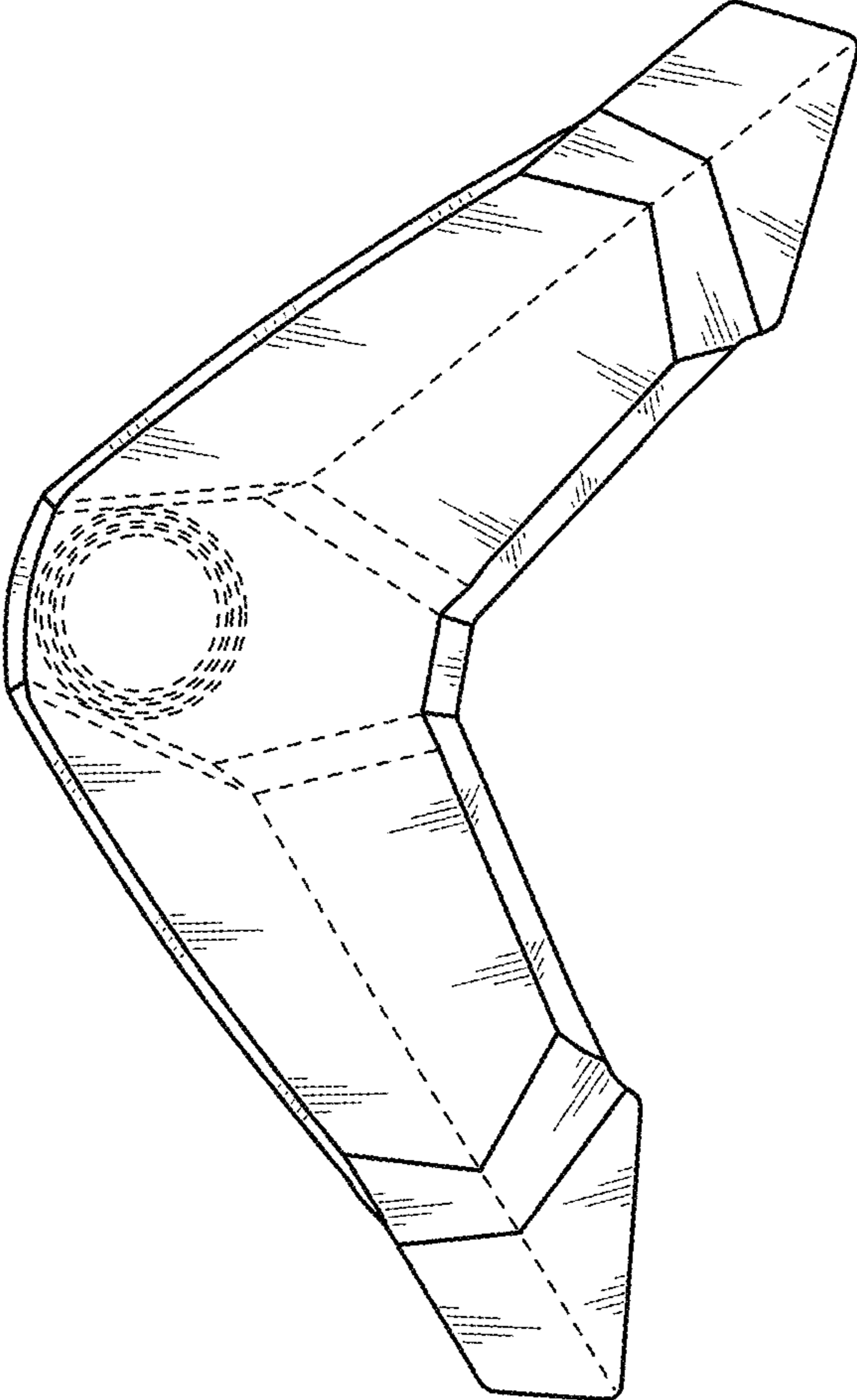

FIG. 2

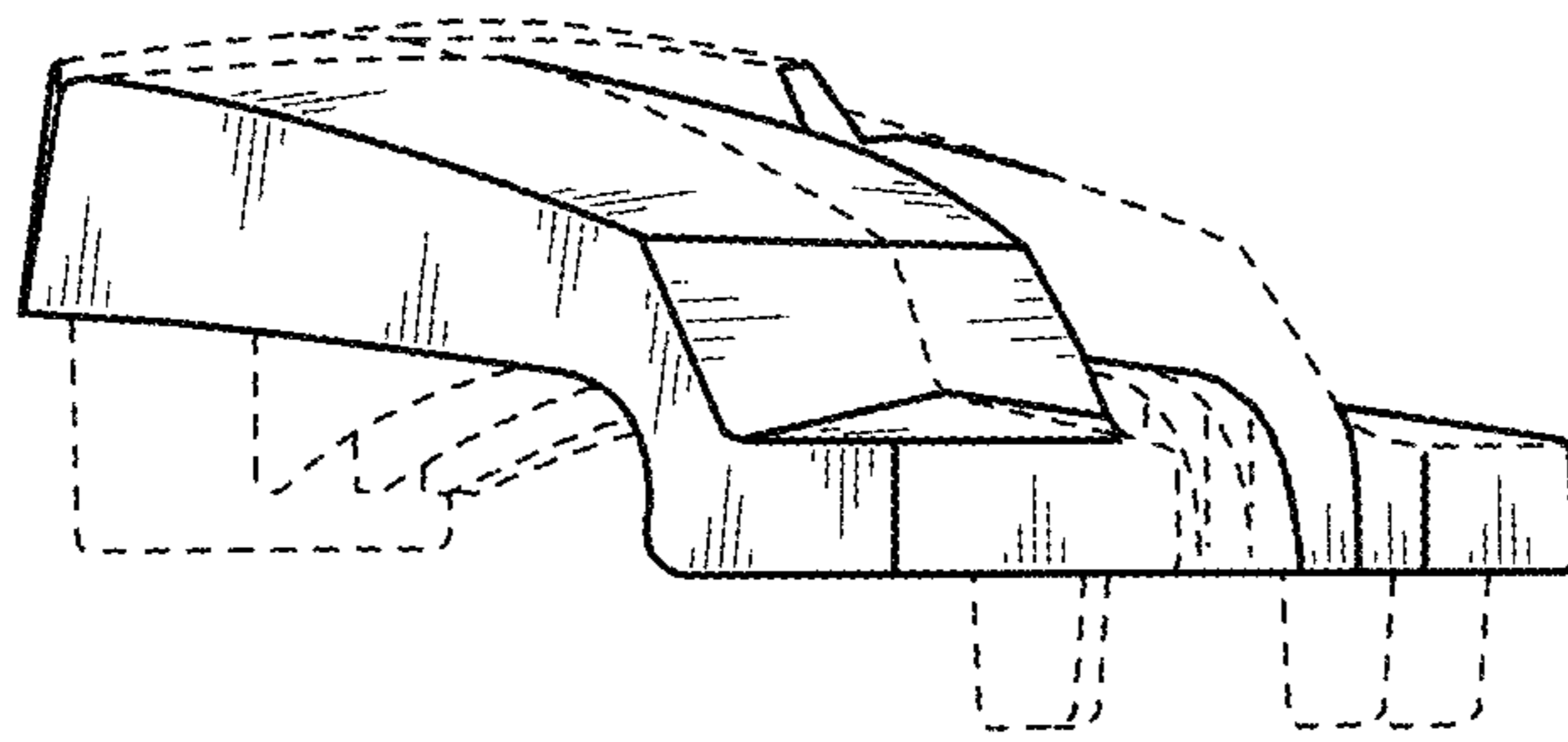

FIG. 4

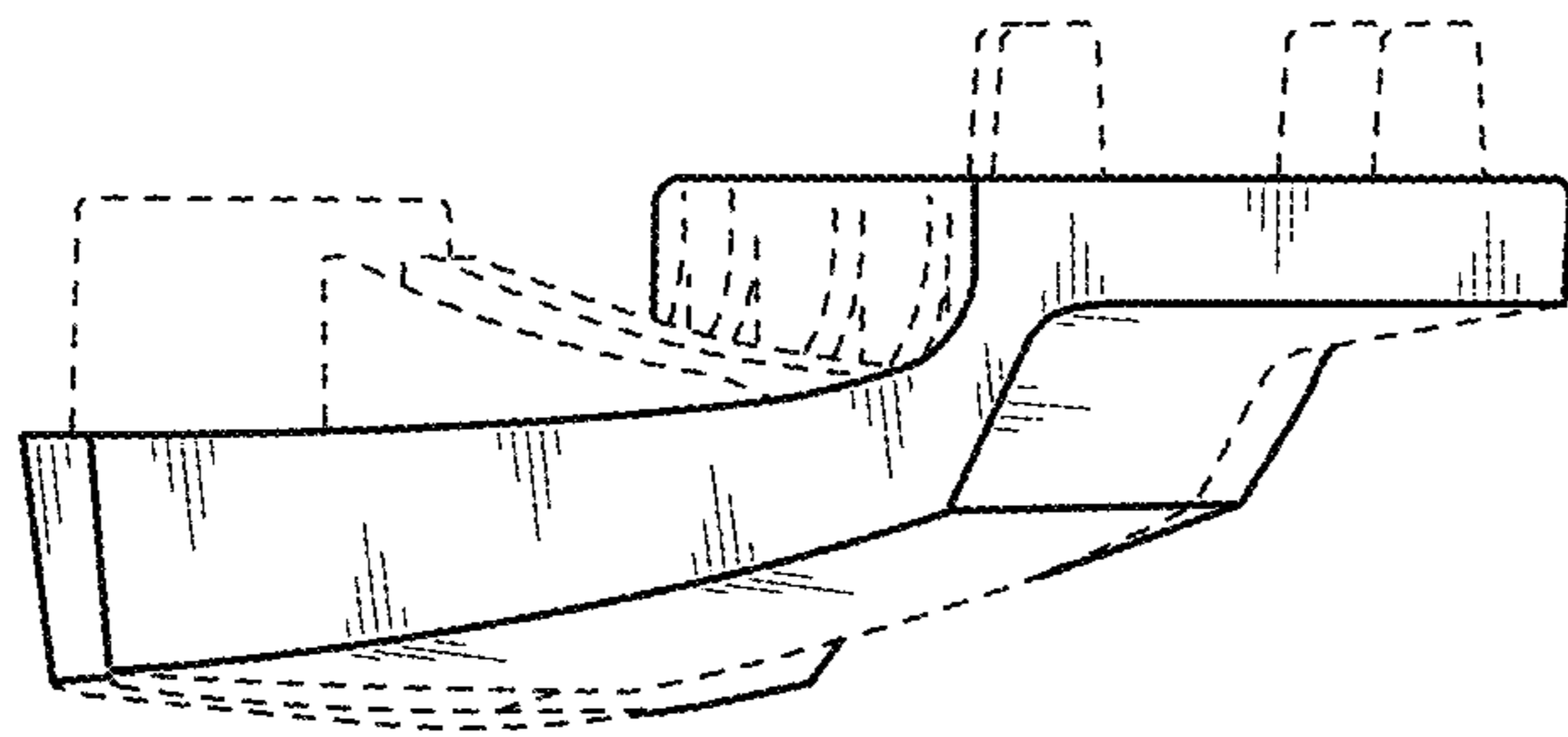

FIG. 3

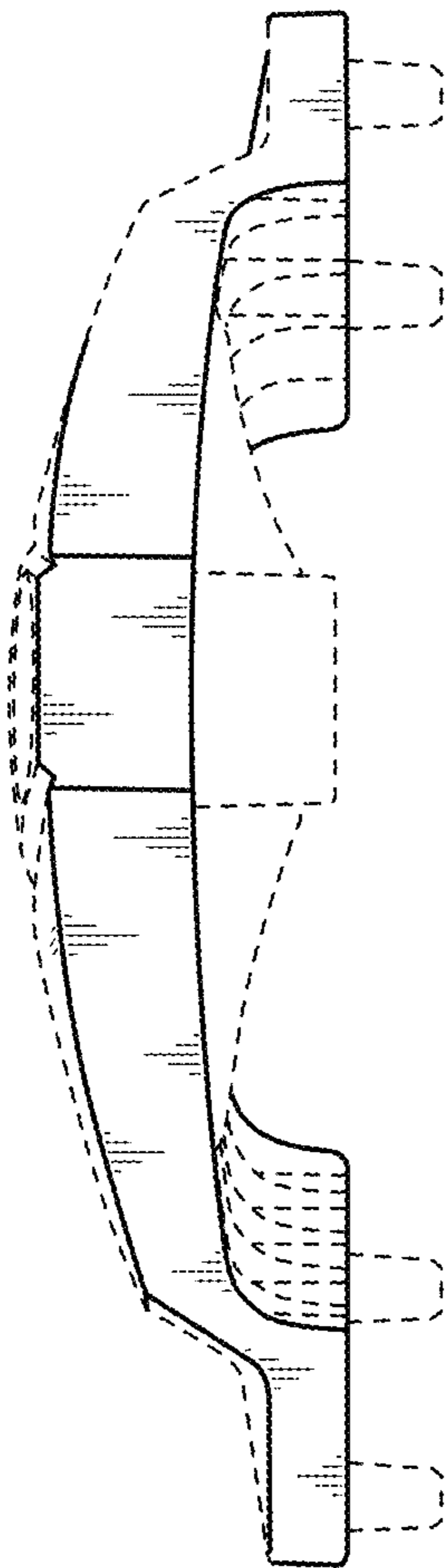

FIG. 5

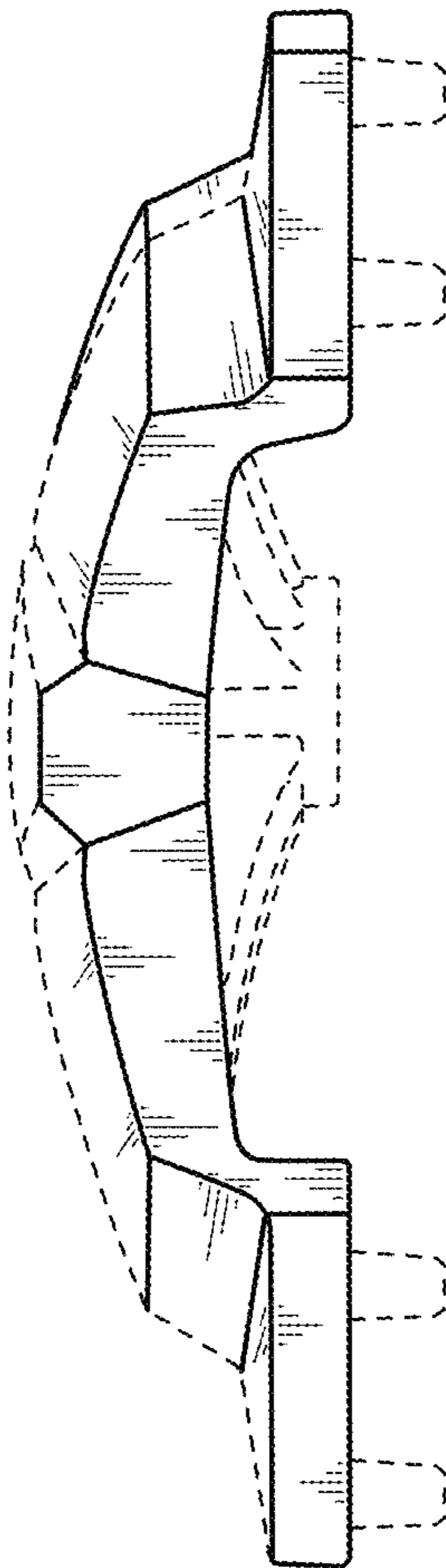

FIG. 6

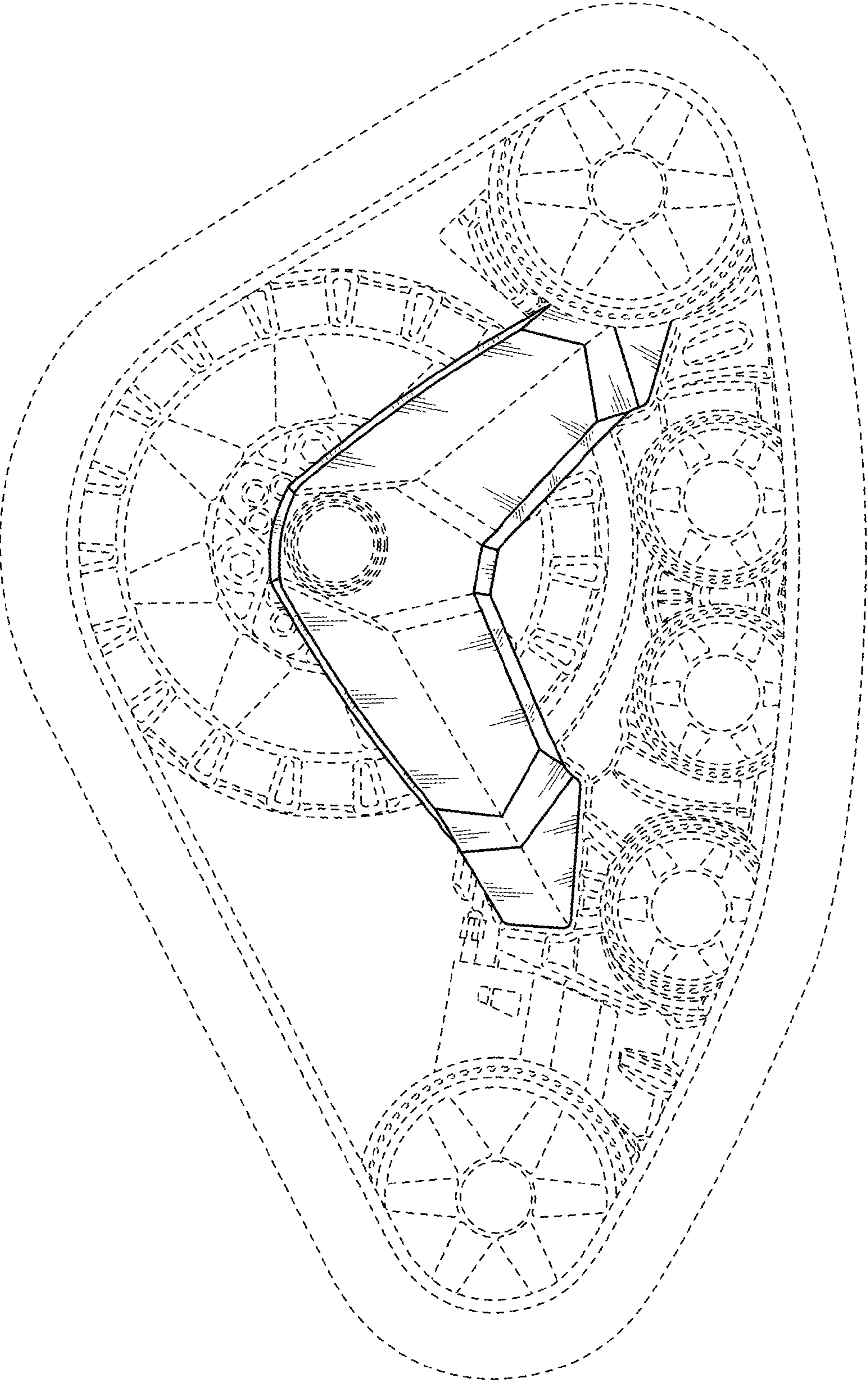

FIG. 7