



US00D681543S

(12) **United States Design Patent**
Fujino et al.

(10) **Patent No.:** **US D681,543 S**

(45) **Date of Patent:** **** May 7, 2013**

(54) **AIRCRAFT FUSELAGE LIGHTS**

(75) Inventors: **Michimasa Fujino**, Summerfield, NC (US); **Greg John Geist**, Summerfield, NC (US); **David Louis Krejsa**, Oakridge, NC (US); **Chris Osborne**, Efland, NC (US)

(73) Assignee: **Honda Motor Co., Ltd.**, Tokyo (JP)

(**) Term: **14 Years**

(21) Appl. No.: **29/403,104**

(22) Filed: **Sep. 30, 2011**

(51) **LOC (9) Cl.** **12-07**

(52) **U.S. Cl.**
USPC **D12/345**

(58) **Field of Classification Search** D26/28-36;
D12/345; 362/459-468, 475-478, 485-487
See application file for complete search history.

(56) **References Cited**

U.S. PATENT DOCUMENTS

D606,682 S * 12/2009 Chang D26/28
D619,277 S * 7/2010 Johnson et al. D26/28

D619,741 S * 7/2010 Beigel et al. D26/28
D620,159 S * 7/2010 Beigel et al. D26/28
D626,057 S * 10/2010 Calvin et al. D12/345
D645,177 S * 9/2011 Okuda D26/28

* cited by examiner

Primary Examiner — Marcus Jackson

(74) *Attorney, Agent, or Firm* — Plumsea Law Group, LLC

(57) **CLAIM**

The ornamental design for aircraft fuselage lights, as shown and described.

DESCRIPTION

FIG. 1 is a perspective view of aircraft fuselage lights showing our new design;
FIG. 2 is a bottom plan view thereof;
FIG. 3 is a side elevational view of one side thereof;
FIG. 4 is a side elevational view of the other side thereof; and,
FIG. 5 is a close-up front elevational view thereof.
The broken line showings of the remainder of the aircraft form no part of the claimed design.

1 Claim, 4 Drawing Sheets

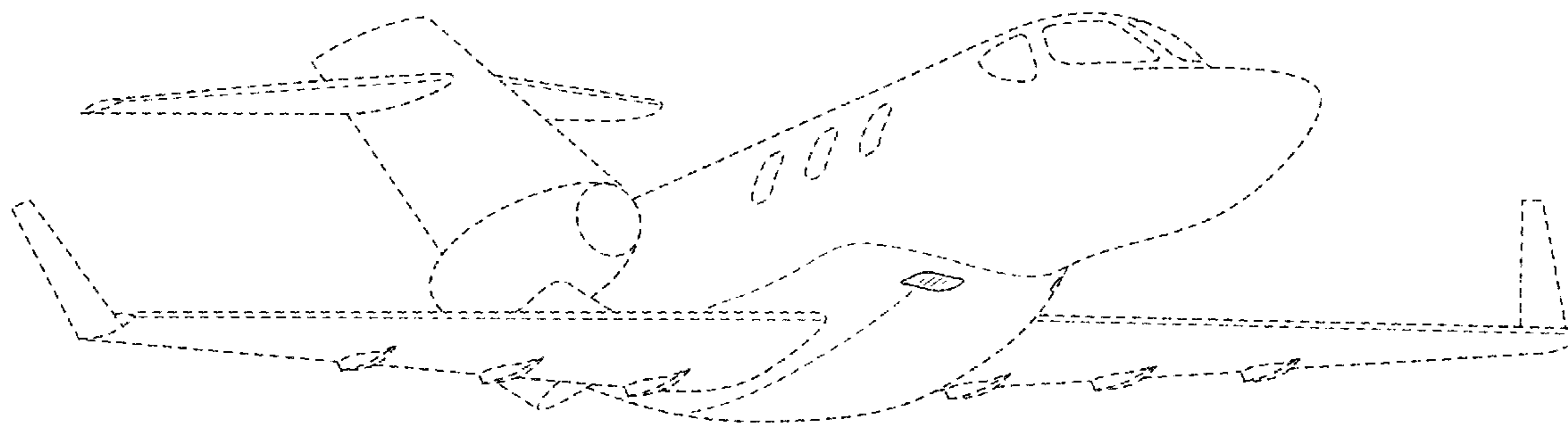

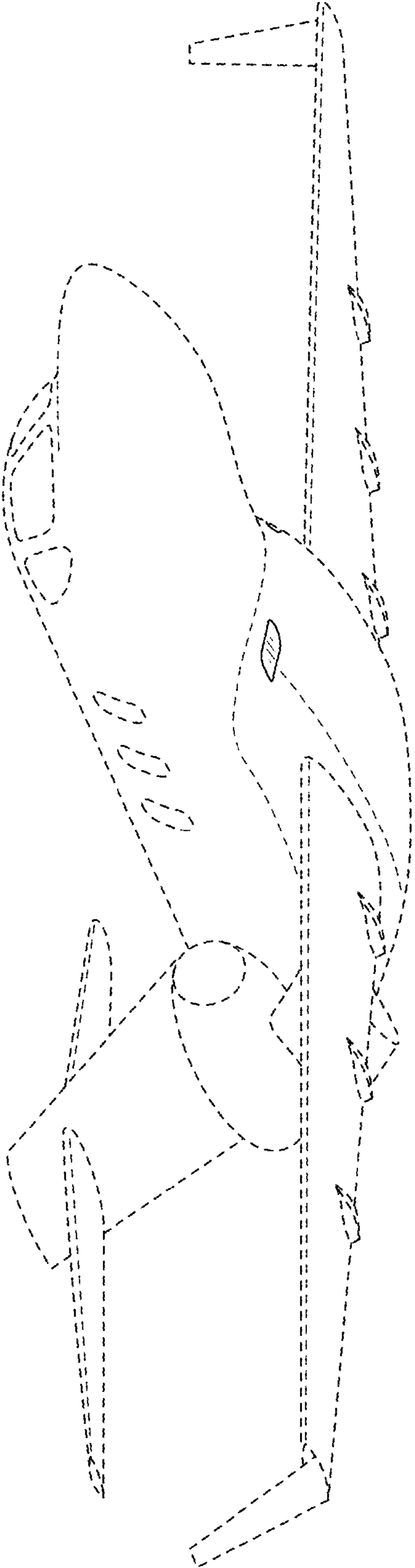

FIG. 1

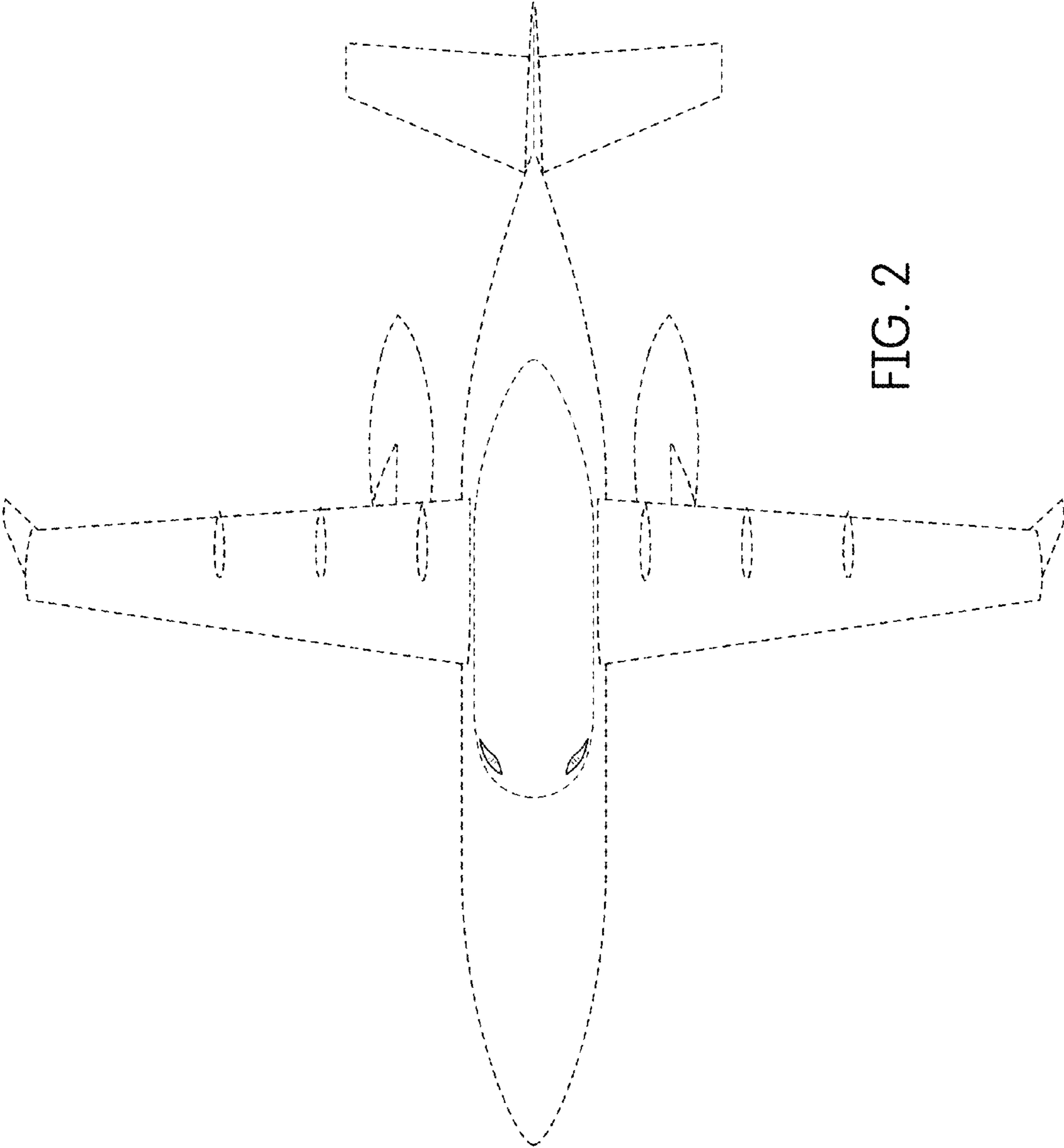

FIG. 2

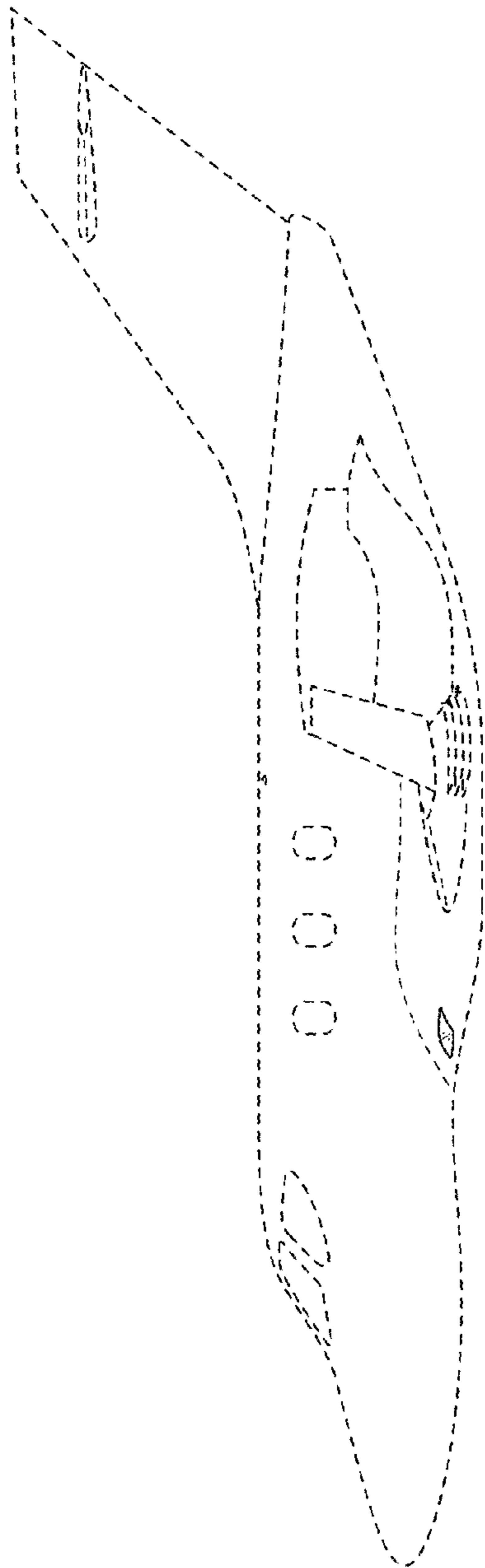

FIG. 3

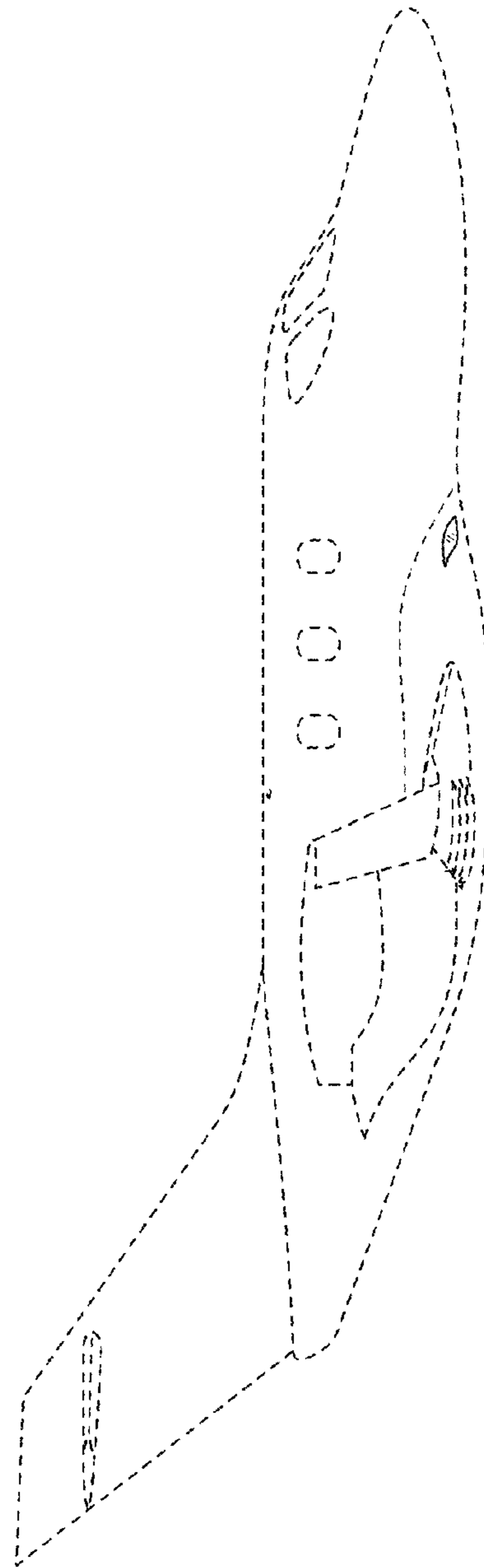

FIG. 4

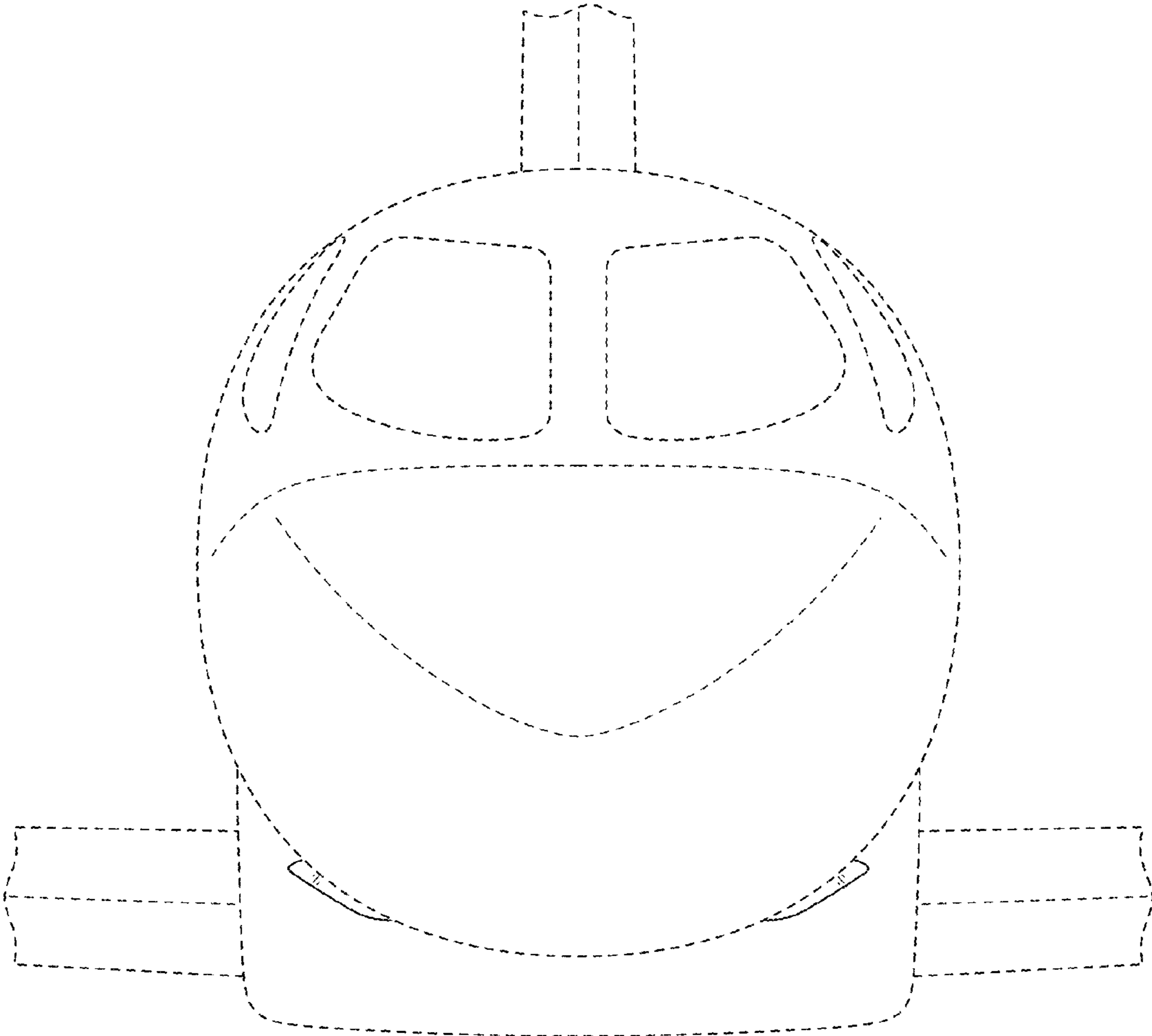

FIG. 5

UNITED STATES PATENT AND TRADEMARK OFFICE
CERTIFICATE OF CORRECTION

PATENT NO. : D681,543 S
APPLICATION NO. : 29/403104
DATED : May 7, 2013
INVENTOR(S) : Michimasa Fujino et al.

Page 1 of 1

It is certified that error appears in the above-identified patent and that said Letters Patent is hereby corrected as shown below:

On the title page item (73) Assignee:

“Honda Motor Co., Ltd., Tokyo (JP)” is replaced with

--Honda Patents & Technologies North America, LLC, Torrance, CA (US)--

Signed and Sealed this
Twenty-ninth Day of October, 2013



Teresa Stanek Rea
Deputy Director of the United States Patent and Trademark Office