



US00D681507S

(12) **United States Design Patent**
Lepine et al.

(10) **Patent No.:** **US D681,507 S**
(45) **Date of Patent:** **** May 7, 2013**

(54) **SNOWMOBILE FAIRING**

(75) Inventors: **Christian Lepine**, Bromont (CA); **Ivan Brousseau**, Granby (CA)

(73) Assignee: **Bombardier Recreational Products Inc.**, Valcourt (CA)

(**) Term: **14 Years**

(21) Appl. No.: **29/413,607**

(22) Filed: **Feb. 17, 2012**

(51) **LOC (9) Cl.** **12-14**

(52) **U.S. Cl.**
USPC **D12/7**

(58) **Field of Classification Search** D12/7,
D12/110, 111, 9, 112, 307, 400, 86, 85, 88;
D21/533; 180/182, 190, 184-186, 9.25,
180/180, 219, 193, 194; 280/845

See application file for complete search history.

(56) **References Cited**

U.S. PATENT DOCUMENTS

D596,530 S * 7/2009 Petit et al. D12/7
D601,453 S * 10/2009 Brew et al. D12/7
8,029,004 B2 * 10/2011 Lemieux 280/28

* cited by examiner

Primary Examiner — T. Chase Nelson

Assistant Examiner — Ania Aman

(74) *Attorney, Agent, or Firm* — BCF LLP

(57) **CLAIM**

The ornamental design for a snowmobile fairing, as shown and described.

DESCRIPTION

FIG. 1 is a perspective view taken from a front, left side of a snowmobile fairing according to our design;

FIG. 2 is a perspective view taken from a rear, left side thereof;

FIG. 3 is a left side elevation view taken from a bottom left side thereof;

FIG. 4 is a front elevation view thereof;

FIG. 5 is a rear elevation view thereof;

FIG. 6 is a top plan view thereof;

FIG. 7 is a bottom plan view thereof;

FIG. 8 a right side elevation view taken from a bottom, right side thereof; and,

FIG. 9 is a perspective view taken from a front, left side thereof shown on a snowmobile shown in dashed lines.

Throughout the Figures, where shown: (i) the dashed lines showing additional structure of the snowmobile fairing are for illustrative purposes only and form no part of the claimed design; (ii) the unshaded surfaces form no part of the claimed design; and (iii) the dotted/dashed lines illustrate unclaimed boundaries of surfaces claimed as part of the design. The invention includes mirror images of the snowmobile fairing shown in the Figures.

The claim includes a second embodiment of the snowmobile fairing, which is a mirror image of the views of the invention shown in the figures.

1 Claim, 9 Drawing Sheets

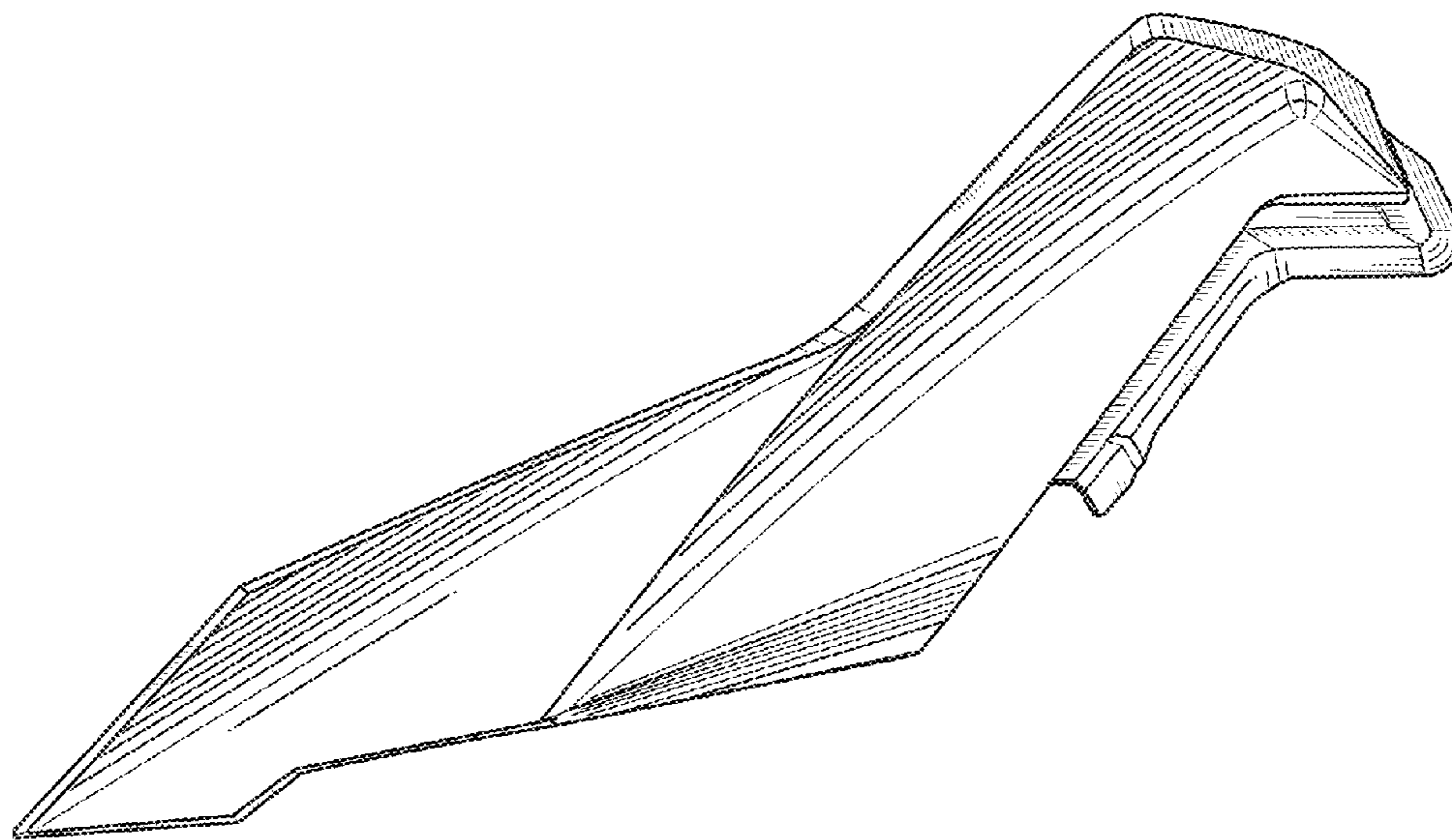

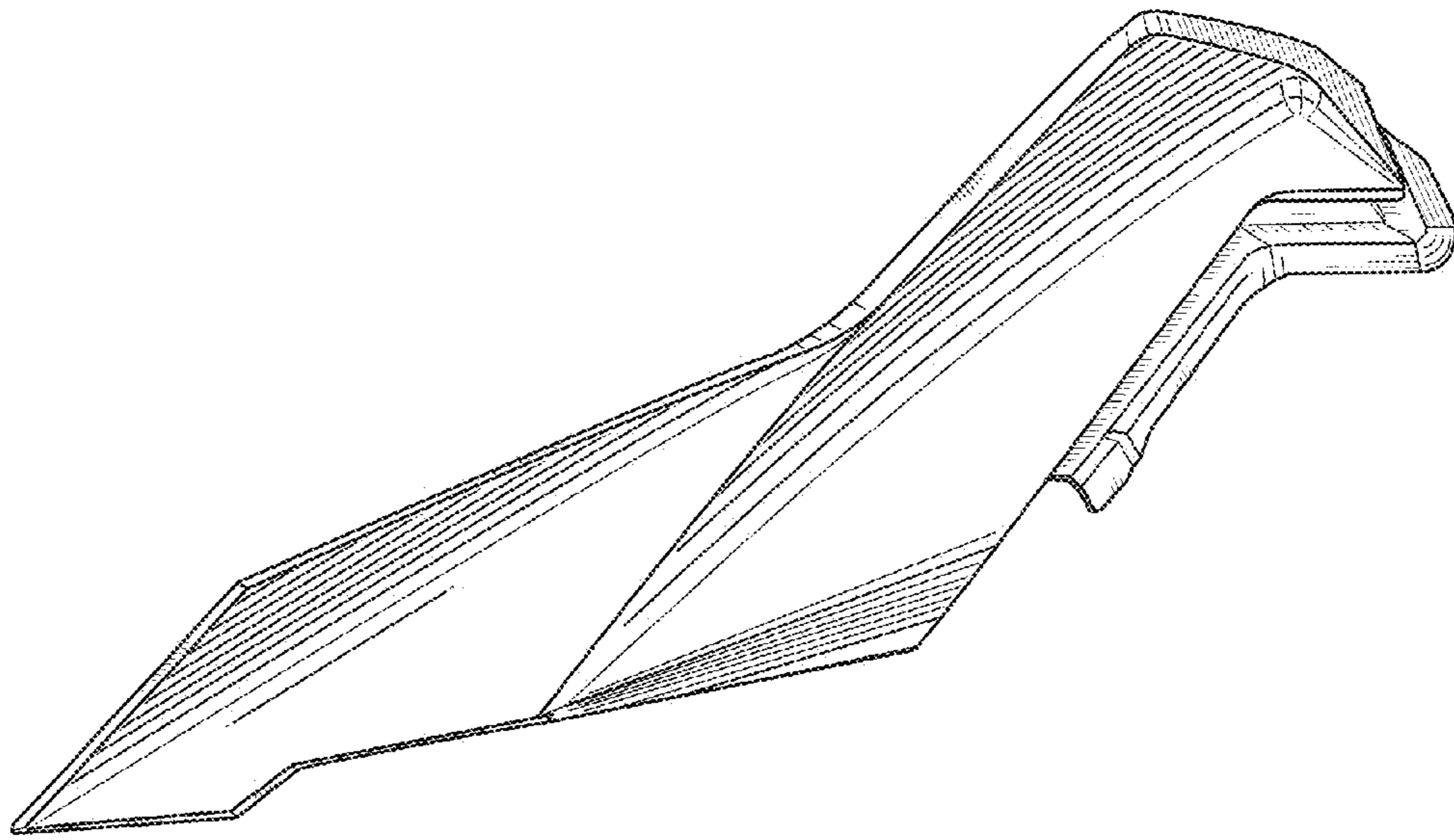

Fig.1

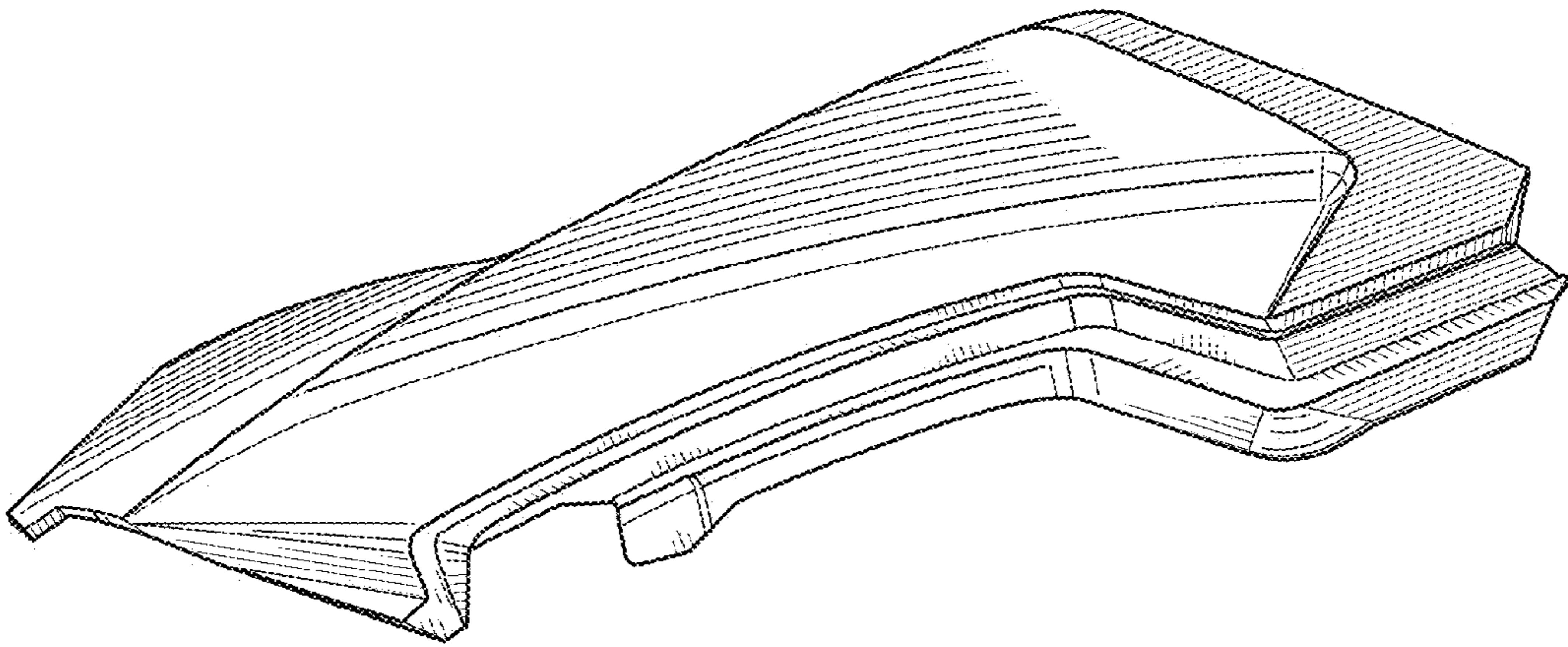

Fig.2

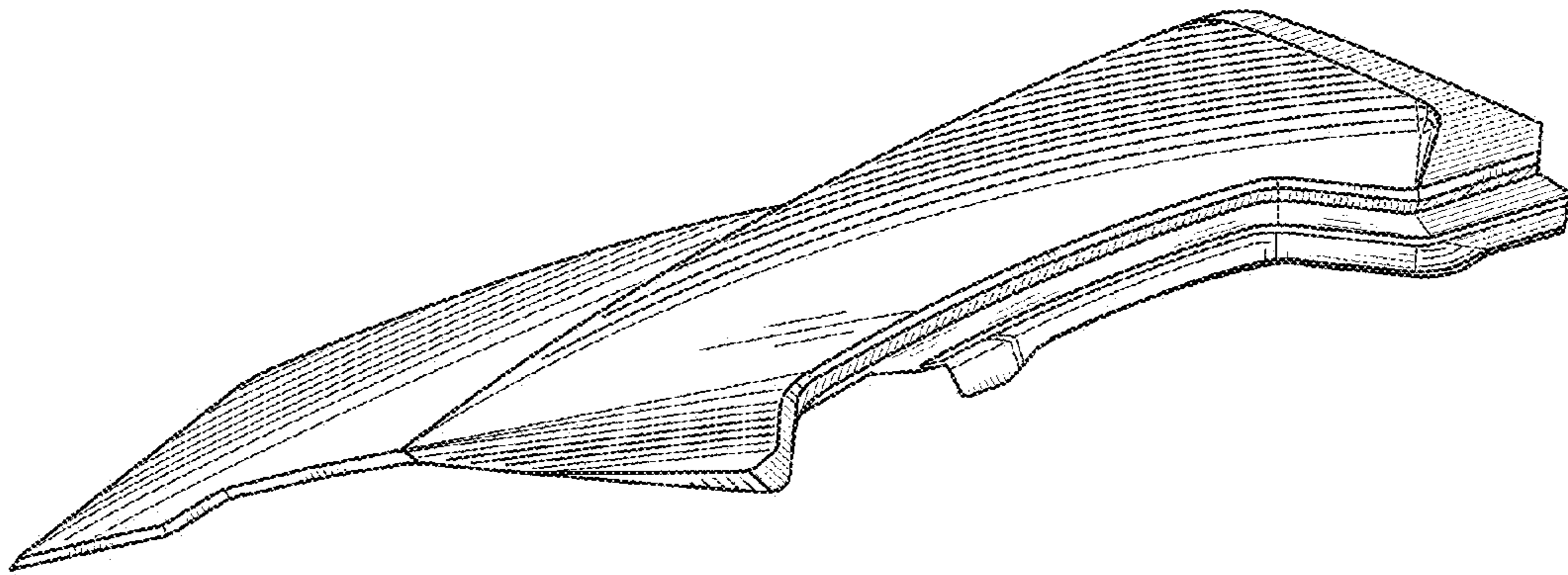

Fig.3

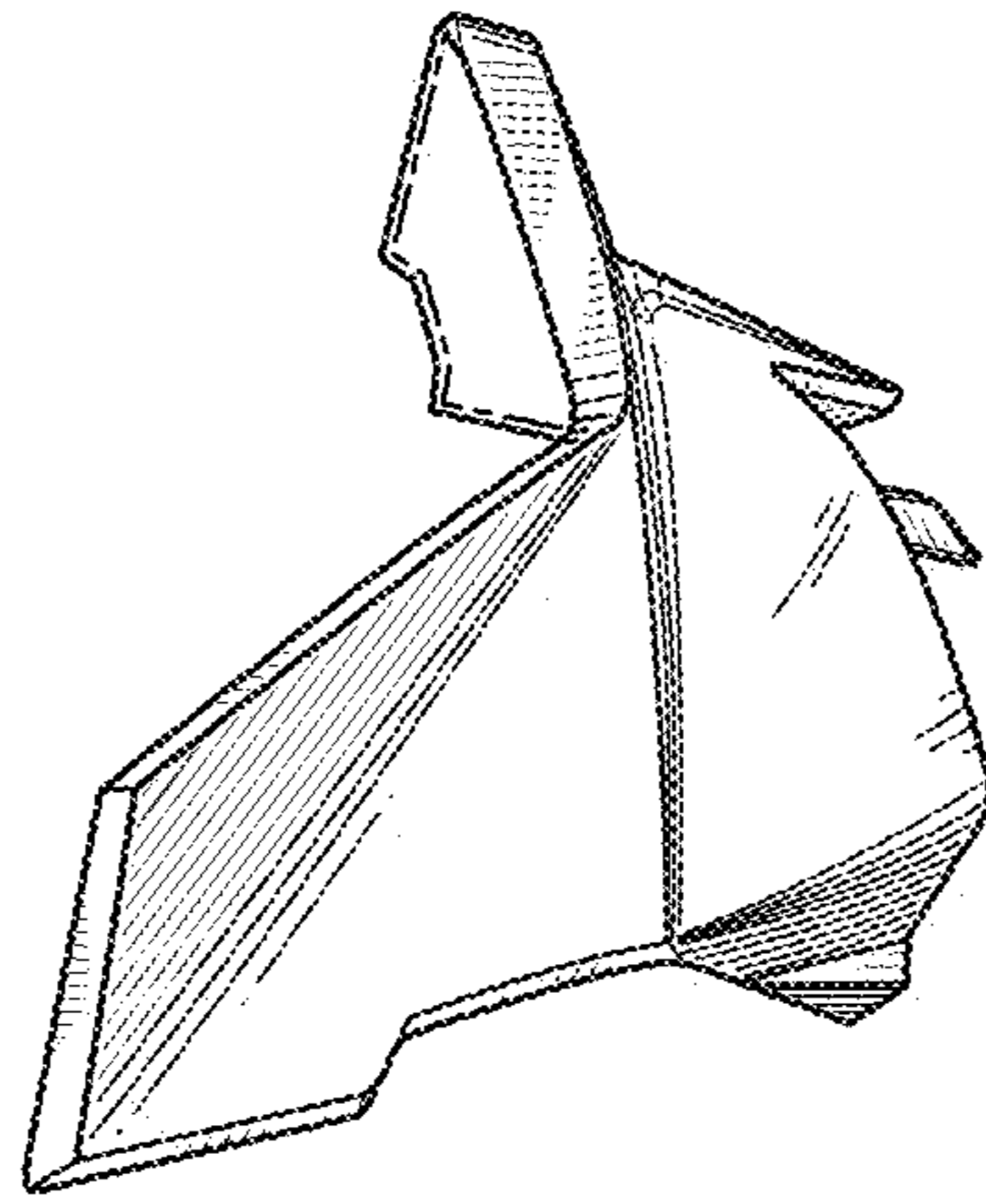

Fig.4

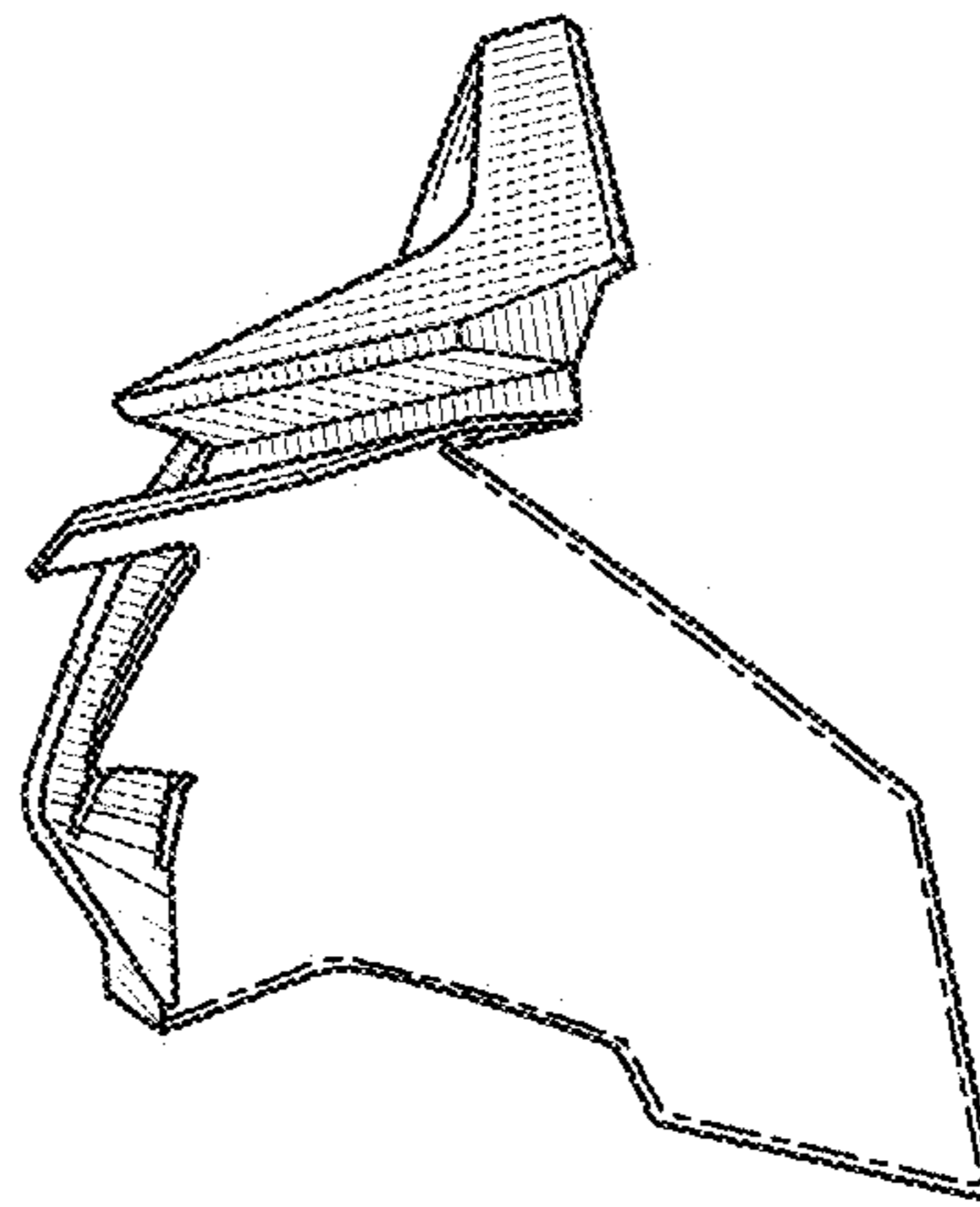

Fig.5

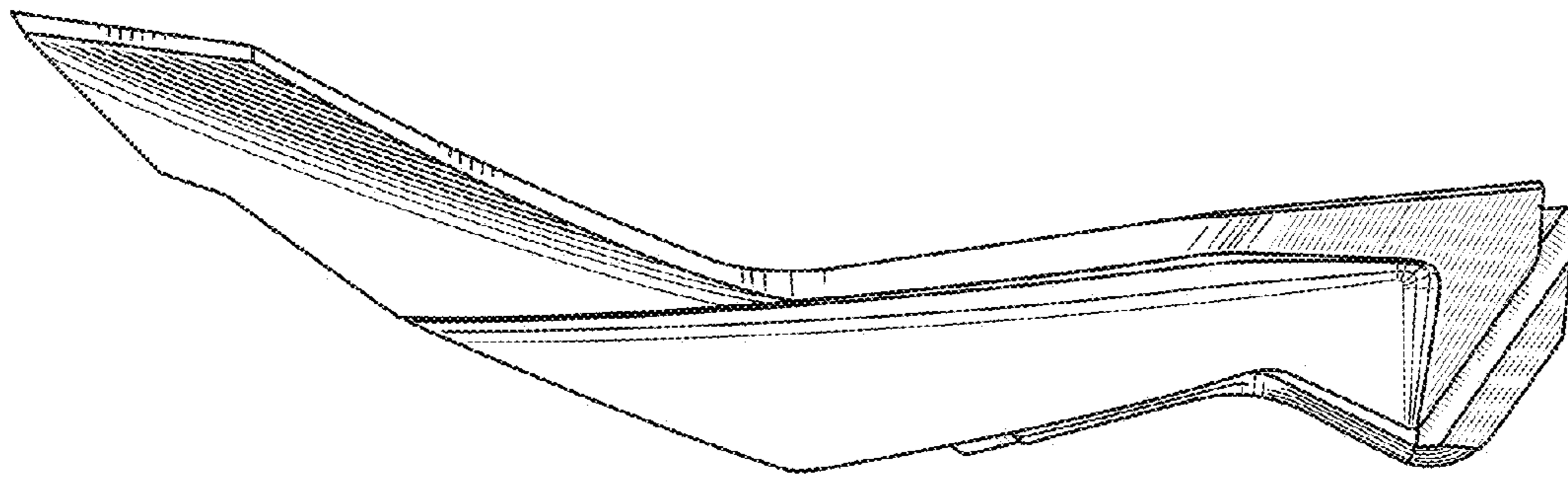

Fig.6

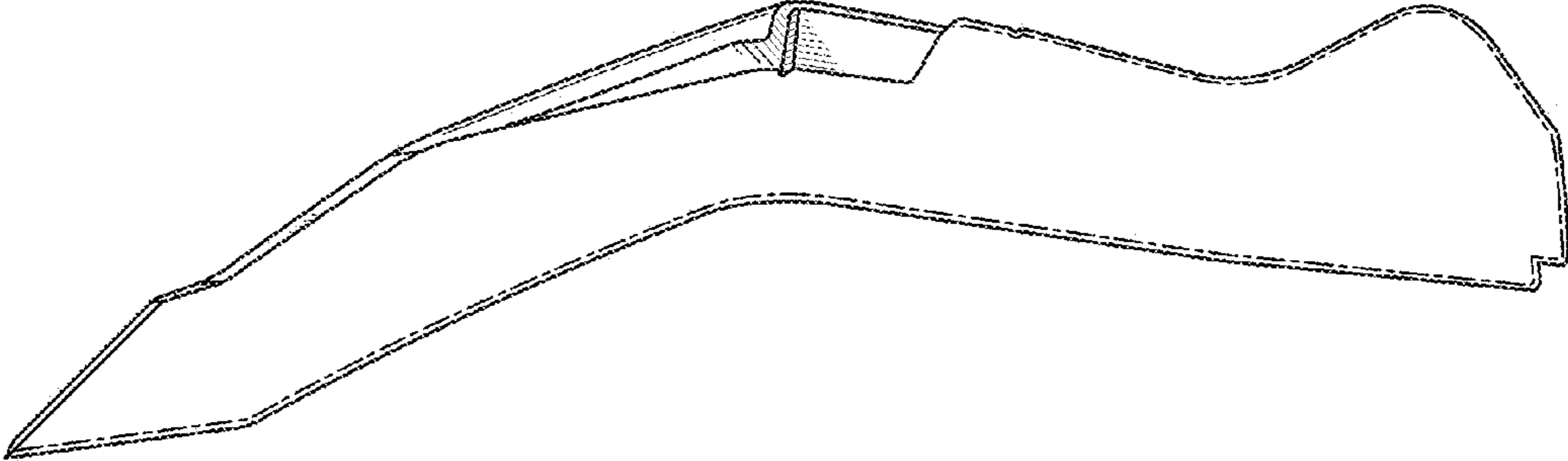

Fig.7

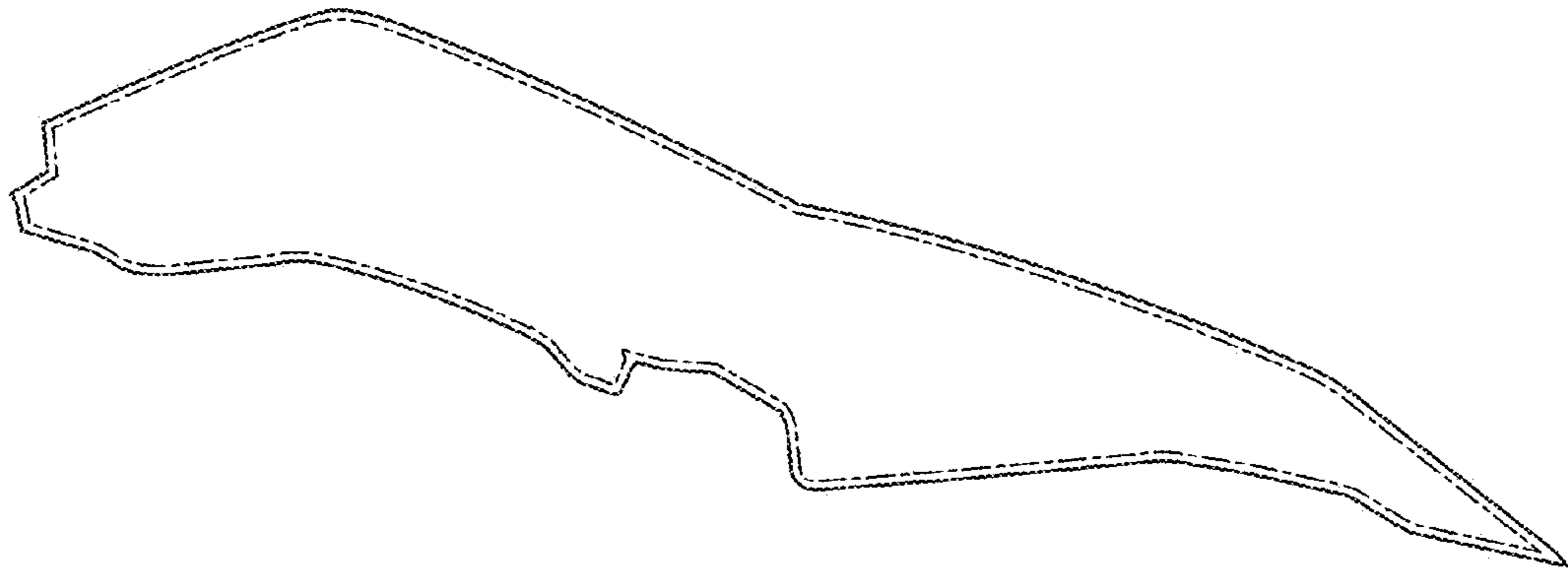

Fig.8

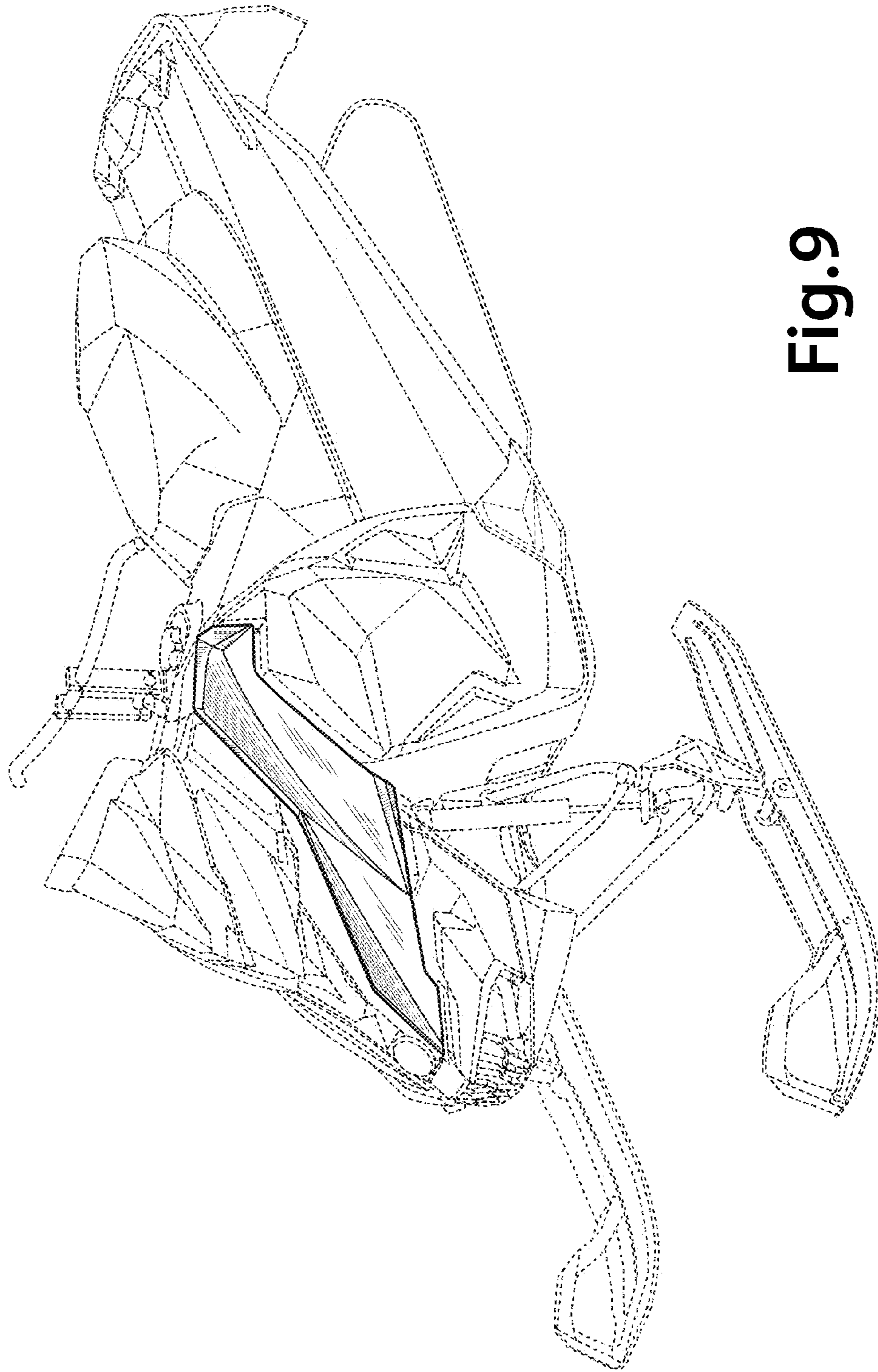

Fig. 9