



US00D681239S

(12) **United States Design Patent**
Hamilton et al.

(10) **Patent No.:** **US D681,239 S**
(45) **Date of Patent:** **** Apr. 30, 2013**

(54) **VEHICLE HEADLIGHT**

(75) Inventors: **Christopher Hamilton**, Bloomfield Hills, MI (US); **Theodore J. Mayer**, St. Clair Shores, MI (US); **Bruce P. Williams**, Grosse Pointe Park, MI (US); **Moray Callum**, Ann Arbor, MI (US)

(73) Assignee: **Ford Motor Company**, Dearborn, MI (US)

(**) Term: **14 Years**

(21) Appl. No.: **29/405,447**

(22) Filed: **Nov. 2, 2011**

(51) **LOC (9) Cl.** **26-06**

(52) **U.S. Cl.**
USPC **D26/28**

(58) **Field of Classification Search** D26/28-36;
362/459-468, 475-478, 485-487
See application file for complete search history.

(56) **References Cited**

U.S. PATENT DOCUMENTS

D538,956 S * 3/2007 Ishii D26/28
D544,614 S * 6/2007 Markefka D26/28
D556,349 S * 11/2007 Golden et al. D26/28

D561,358 S * 2/2008 Tachibana D26/28
D571,025 S 6/2008 Golden
D593,232 S * 5/2009 Koman et al. D26/28
D608,032 S 1/2010 Walter

OTHER PUBLICATIONS

Aston Martin Brochure.
Car Advice, Oct. 5, 2011, 2013 Ford Mondeo Mule Spy Photot.
Ford EVOS Concept Brochure.

* cited by examiner

Primary Examiner — Marcus Jackson
(74) *Attorney, Agent, or Firm* — Damian Porcari

(57) **CLAIM**

The ornamental design for a vehicle headlight, as shown and described.

DESCRIPTION

FIG. 1 is a left side elevational view of a left vehicle headlight (the right vehicle headlight being a mirror image and is not shown);
FIG. 2 is a right side elevational view of the vehicle headlight;
FIG. 3 is a front elevational view of the vehicle headlight;
FIG. 4 is a top plan view of the vehicle headlight;
FIG. 5 is a bottom plan view of the vehicle headlight;
FIG. 6 is a perspective view of the vehicle headlight; and,
FIG. 7 is another perspective view of the vehicle headlight.

1 Claim, 7 Drawing Sheets

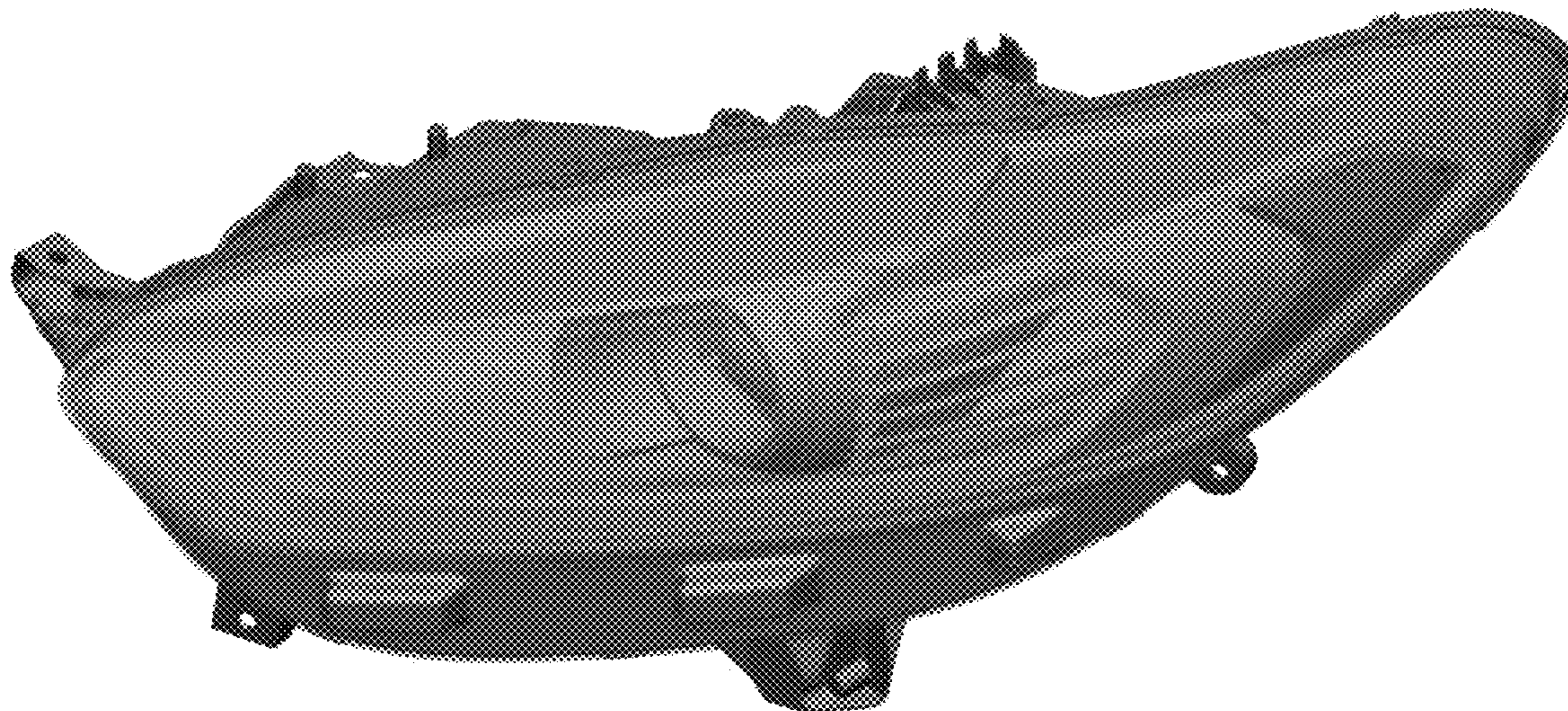

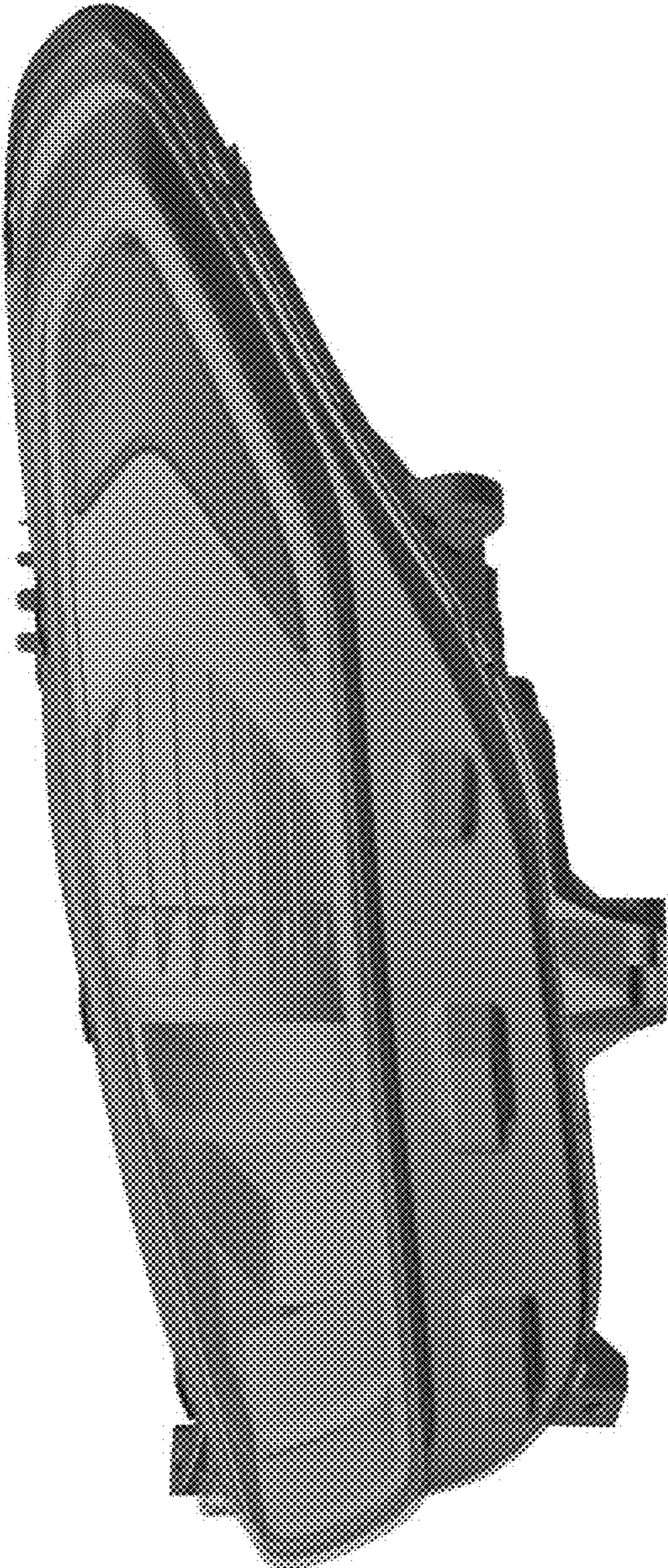

Figure 1

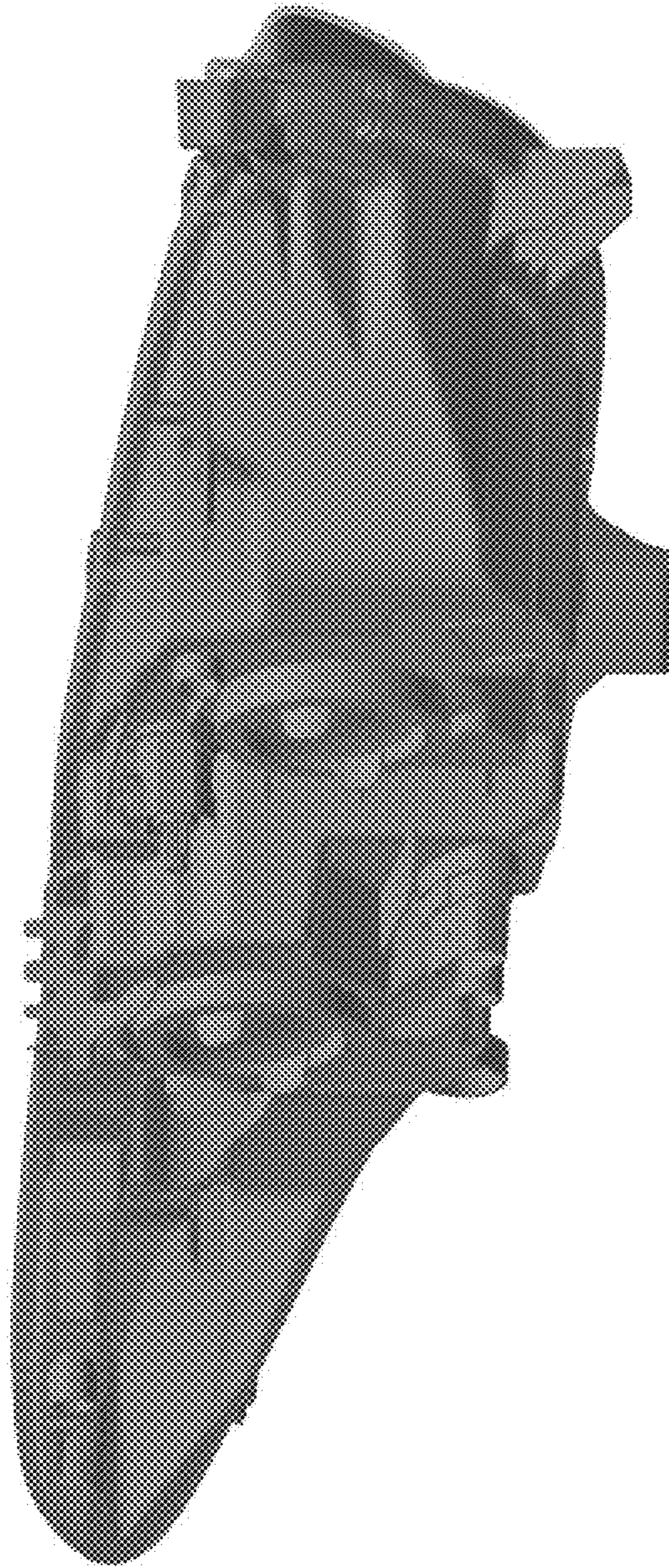

Figure 2

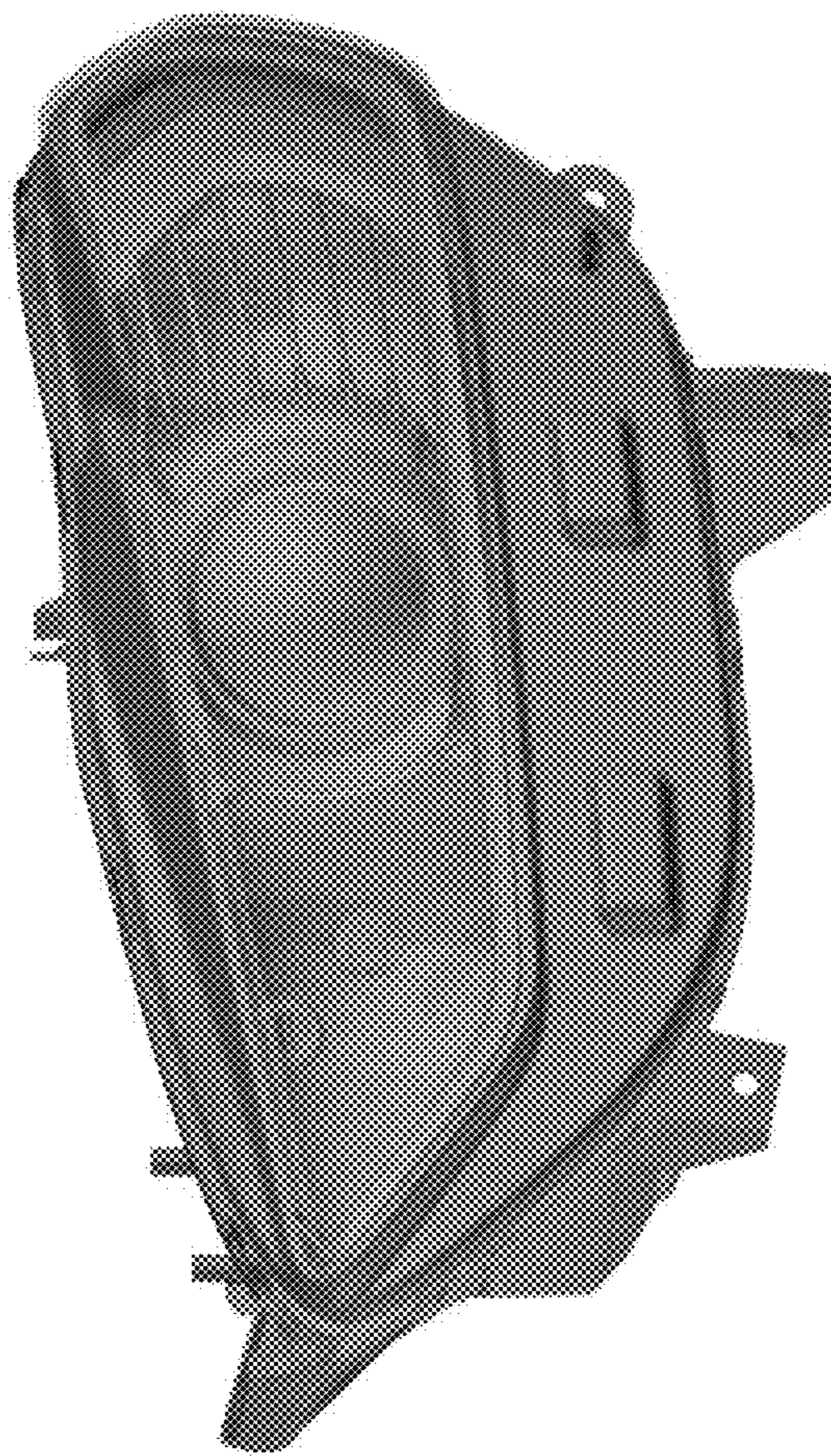

Figure 3

Figure 4

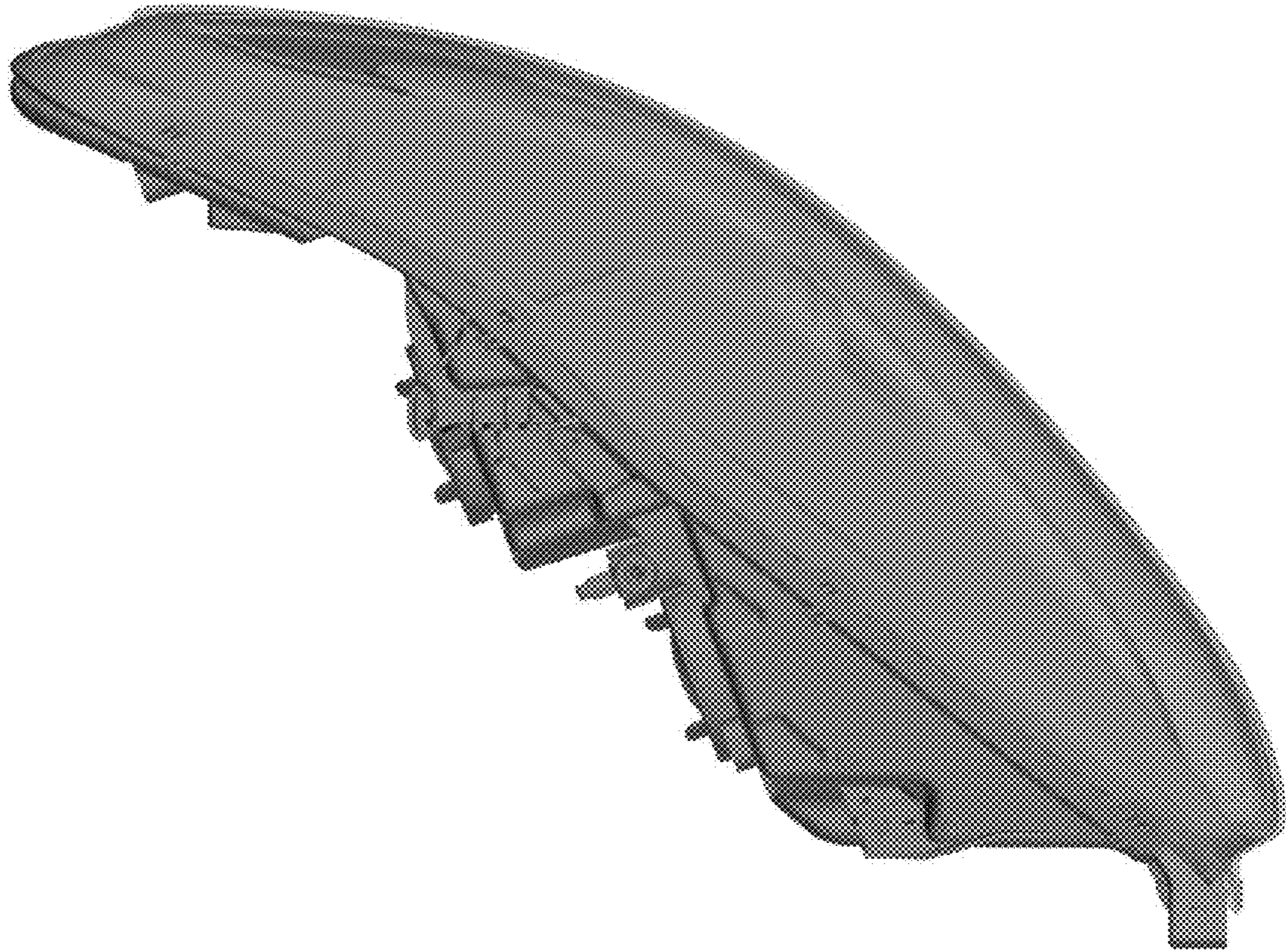
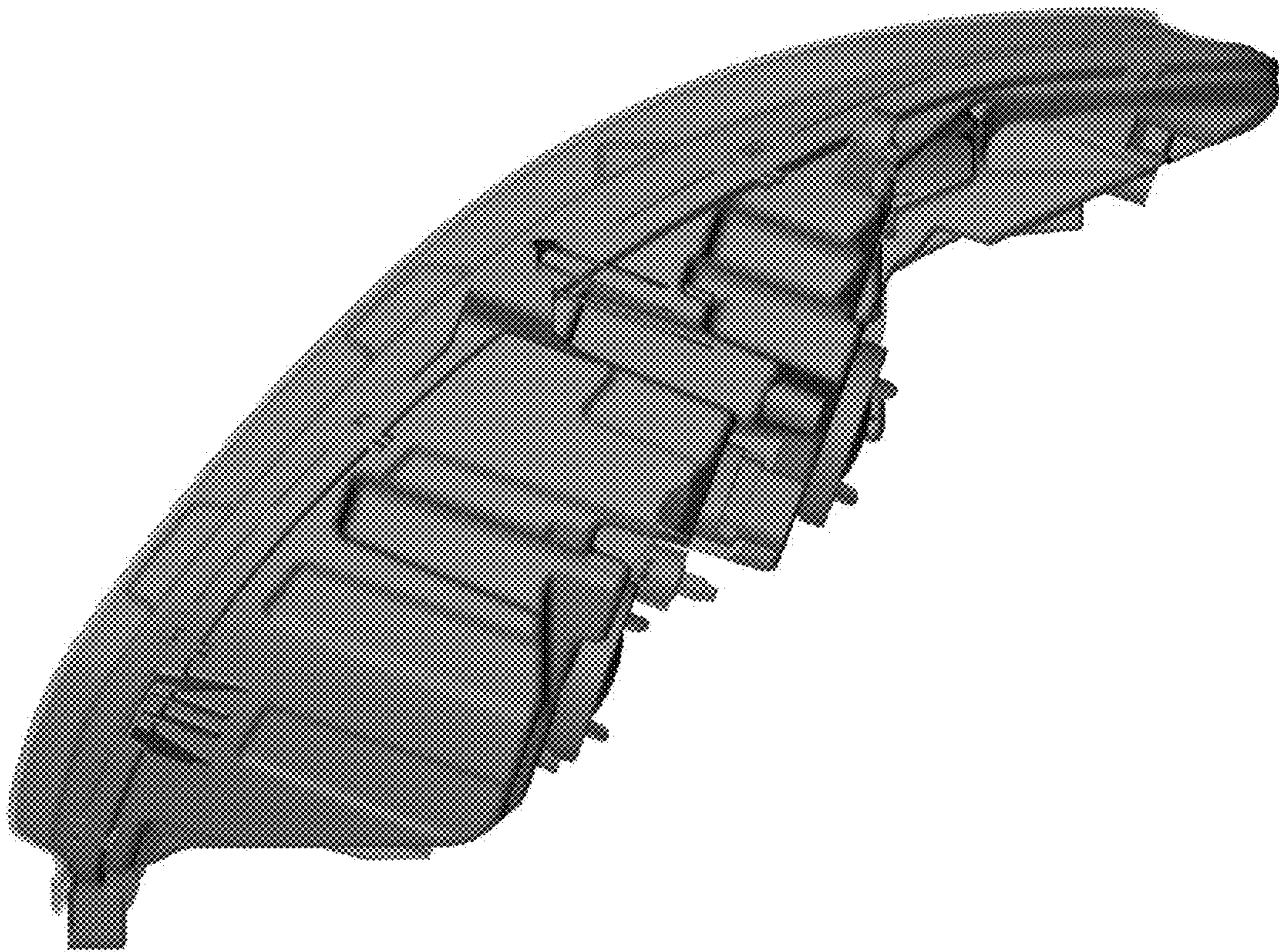

Figure 5



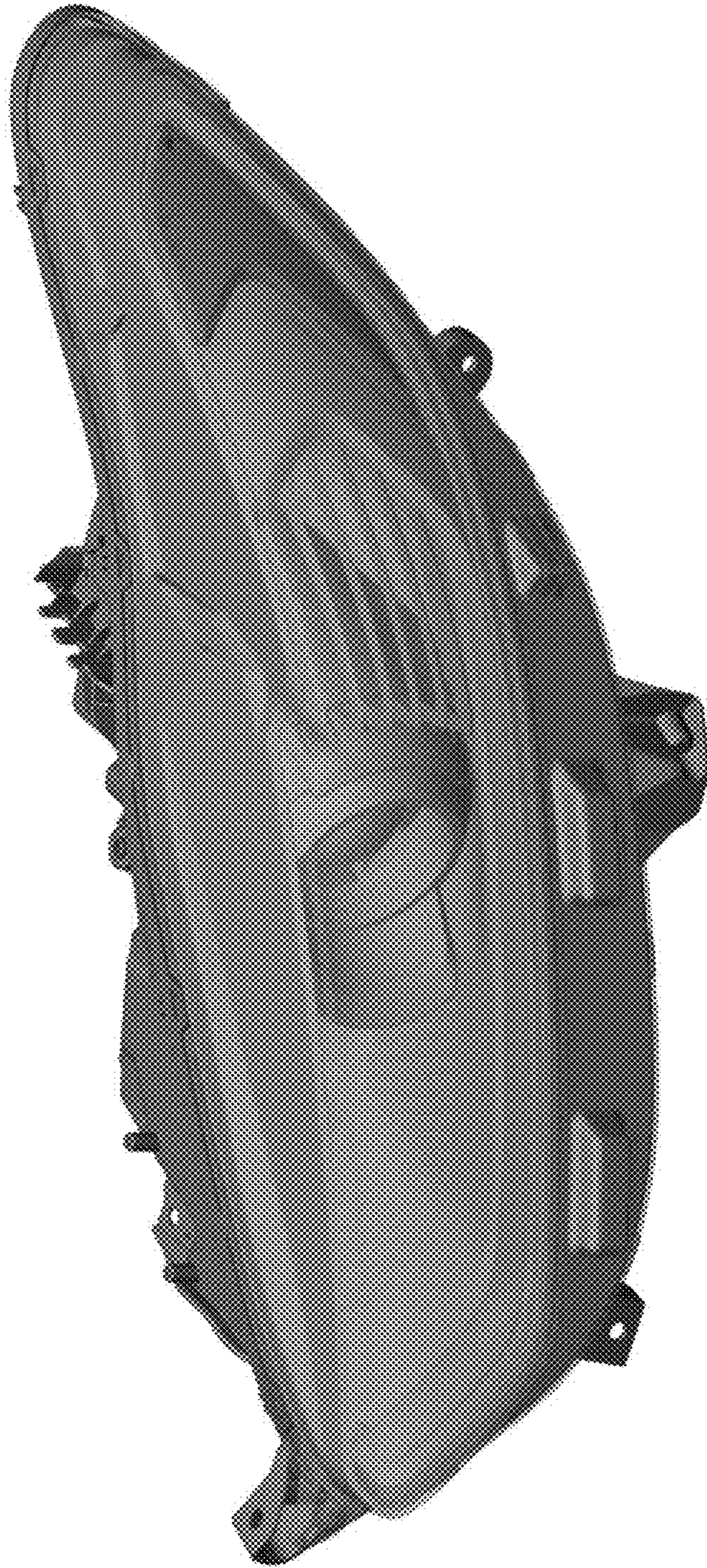

Figure 6

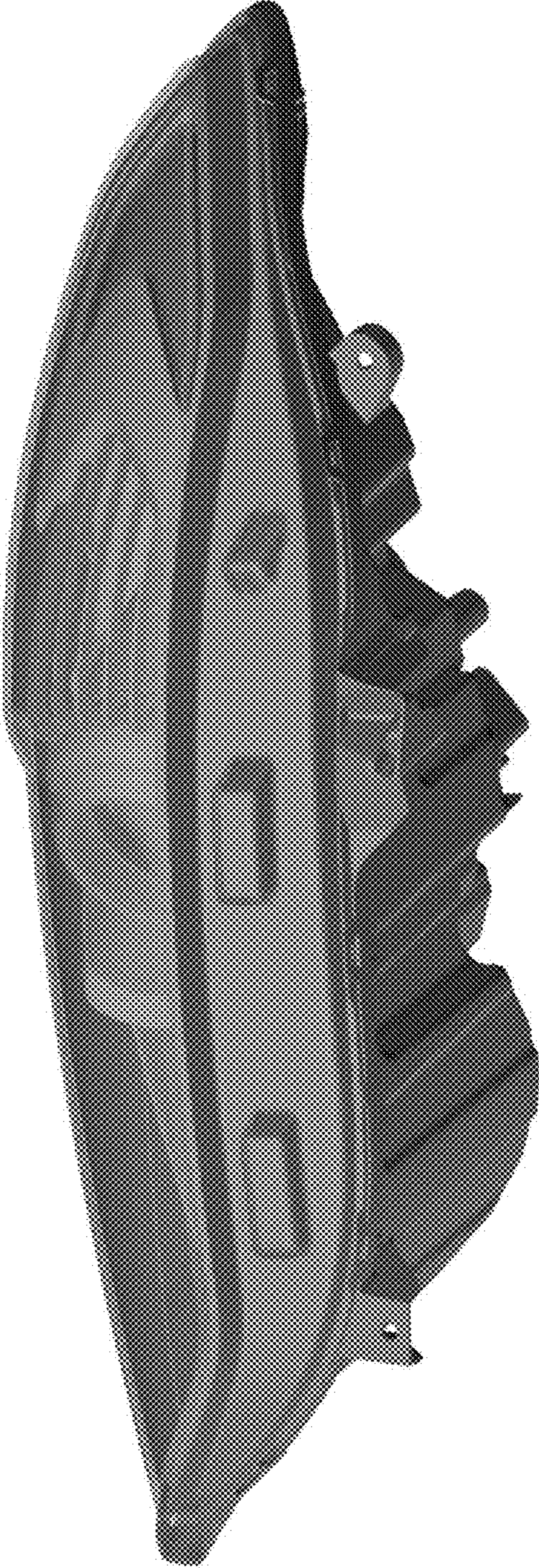

Figure 7